



## 2-Wire Photoelectric Duct Smoke Detector



*The InnovairFlex™ Series are the only duct smoke detectors flexible enough to fit configurations from square to rectangular and everything in between.*

**Innovairflex™**

### Features

- Photoelectric, integrated low-flow technology
- Air velocity rating from 100 ft/min to 4,000 ft/min (0.5 m/s to 20.32 m/sec)
- Versatile mounting options in square or rectangular configuration with modular construction
- Plug-in sensor
- Superb false alarm immunity with the latest sensor technology
- Broader ranges for operating temperature (-4°F to 158°F) and humidity (0% to 95% non-condensing)
- Patented sampling tube installs from front or back of the detector with no tools required
- A cover tamper feature to indicate a trouble condition for removed or improperly installed sensor cover
- Increased wiring space with a newly added 3/4 inch conduit knockout
- Improved LED status
- 24 VDC
- Backward compatibility with existing Innovair products, including remote accessories

**The InnovairFlex D2A** 2-wire photoelectric duct smoke detector features a pivoting housing that fits various applications: both square and rectangular footprints mount to round or rectangular duct work.

This new duct smoke detector senses airflow speeds ranging from 100 to 4,000 feet per minute with proven System Sensor precision. The enhancements built into this model improve false alarm immunity (with plug-in sensor head); broaden operating temperature (-4°F to 158°F) and humidity (0 to 95 percent non-condensing) ranges; while simplifying installation and maintenance. These advance features can detect smoke even in the harshest duct applications.

The new design provides more wiring space with an added 3/4 inch conduit knockout. Numbers and labels for terminal designations are consistent with previous Innovair models. The new sampling tube can be clicked into position with one smooth motion from either the front or the back of the detector.

The InnovairFlex D2A duct smoke detector has signals to indicate trouble and maintenance conditions. Additionally, a cover tamper feature is incorporated to indicate a trouble condition for removed or improperly installed sensor cover. An improved cover design, with an integrated the low-flow feature, isolates the sensor head from the low-flow technology for simple maintenance.

The InnovairFlex series is designed for greater flexibility and reliable smoke detection to simplify installation and maintenance. The new InnovairFlex product line is backward compatible to existing Innovair models, including remote test accessories

**WARNING:** Duct smoke detectors have specific limitations.

DUCT SMOKE DETECTORS ARE:

**NOT** a substitute for an open area smoke detector,  
**NOT** a substitute for early warning detection, and  
**NOT** a replacement for a building's regular fire detection system.  
Refer to NFPA 72, 90A and CAN/ULC S524 for additional duct smoke detector application information.

### Agency Listings



## InnovairFlex Duct Smoke Detector Specifications

### Architectural/Engineering Specifications

The air duct smoke detector shall be a System Sensor InnovairFlex™ D2A Photoelectric Duct Smoke Detector. The detector housing shall be ULC listed specifically for use in air handling systems. The flexible housing of the duct smoke detector fits both square and rectangular footprints. The detector shall operate at air velocities of 100 ft/min to 4000 ft/min (0.5 m/sec to 20.32 m/sec). The unit shall be capable of providing a trouble signal in the event that the sensor cover is removed or improperly installed. It shall be capable of local testing via magnetic switch or remote testing using the RTS151KEYA remote test station. Terminal connections shall be of the strip and clamp method suitable for 12–18 AWG wiring.

### Physical Specifications

**Size: (Rectangular)** 14.38 in (37 cm) Length; 5 in (12.7 cm) Width; 2.5 in (6.36 cm) Depth  
**(Square)** 7.75 in (19.7 cm) Length; 9 in (22.9 cm) Width; 2.5 in (6.35 cm) Depth

**Weight:** 1.8 lb (0.82 kg)

**Operating Temperature Range:** -4°F to 158°F (-20°C to 70°C)

**Storage Temperature Range:** -22°F to 158°F (-30° to 70°C)

**Operating Humidity Range:** 0% to 95% relative humidity non-condensing

**Air Duct Velocity:** 100 to 4000 ft/min (0.5 to 20.32 m/sec)

### Electrical Ratings

**Power supply voltage:** 8.5-35 VDC

**Input capacitance:** 0.1  $\mu$ F max.

**Reset voltage:** 2.5 VDC min.

**Reset time: (with RTS151KEYA)** 0.03 to 0.3 sec.

**Reset time: (by power down)** 0.3 sec. max.

**Power up time:** 35 sec. max.

**Alarm response time:** 15 sec.

**Sensitivity Test:** See detector label

### Current Requirements: (Using No Accessories)

**Peak standby current:** 120  $\mu$ A

**Max. standby current:** 60  $\mu$ A (average)

**Max. alarm current:** 130 mA

### Accessory Current Loads at 24 VDC

Device	Standby	Alarm
RA100ZA	0 mA	12 mA Max.
RTS151KEYA	12 mA	12 mA Max.

## Installing the InnovairFlex Sampling Tube

The InnovairFlex sampling tube may be installed from the front or back of the detector. The tube locks securely into place and can be removed by releasing the front or rear locking tab (front locking tab shown below right).



## Wiring for 2-wire Duct Smoke Detector

System wiring diagram for 2-wire duct smoke detectors (powered from initiating device circuit):

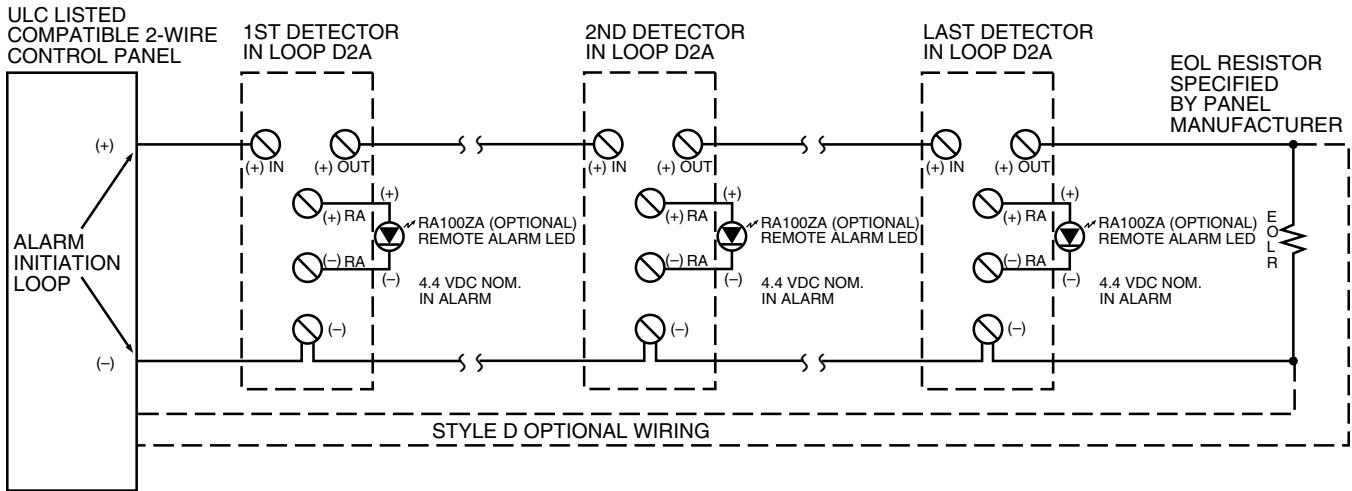

Wiring diagram for 2-wire duct smoke detector to RTS151KEYA Remote Test Station

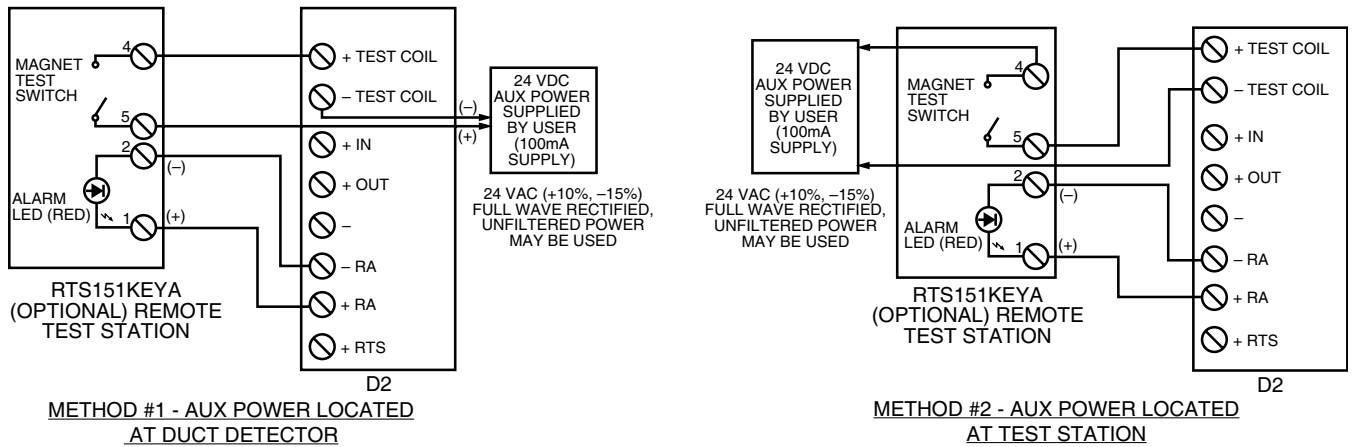

## Important Note

The use of RTS151KEYA requires the installation of an accessory coil, DCOIL, sold separately. Please refer to the D2A installation manual for more information

## Accessories

System Sensor provides system flexibility with a variety of accessories, including two remote test stations and different means of visible system annunciation. As with our duct smoke detectors, all duct smoke detector accessories are ULC listed.



RTS151KEYA



RA100ZA

## Ordering Information

Part No.	Description
D2A	2-wire photoelectric low-flow duct smoke detector
<b>Accessories</b>	
2151A	2-wire conventional photoelectric sensor head
DCOIL	2-wire remote test coil required with RTS451/RTS451KEY
DST1	Metal sampling tube duct width up to 1ft (0.3m)
DST1.5	Metal sampling tube duct widths 1 ft to 2 ft (0.3 to 0.6 m)
DST3	Metal sampling tube duct widths 2 ft to 4 ft (0.6 to 1.2 m)
DST5	Metal sampling tube duct widths 4 ft to 8 ft (1.2 to 2.4 m)
DST10	Metal sampling tube duct widths 8 ft to 12 ft (2.4 to 3.7 m)
DH400OE-1	Weatherproof enclosure
ETX	Metal exhaust tube duct width 1ft (0.3m)
M02-04-00	Test magnet
P48-21-00	End cap for metal sampling tubes
RA100ZA	Remote annunciator alarm LED
RTS451KEY-A	Remote test station with key lock



6-6581 Kitimat Road • Mississauga ON, L5N 3T5  
Phone: 800-SENSOR2 • www.systemsensor.ca

©2009 System Sensor.  
Product specifications subject to change without notice. Visit [www.systemsensor.ca](http://www.systemsensor.ca) for current product information, including the latest version of this data sheet.  
A05-0414-000