

by Honeywell

Description

The System Sensor 1415 ionization type smoke detectors are specifically designed to meet the performance requirements of fire detection and fire alarm systems. The 1415 ionization detector uses a state-of-the-art, dual unipolar sensing chamber. The detector is designed to provide open area detection and when installed in a two-wire base is compatible with Gamewell-FCI fire alarm control panels. The detectors operation and sensitivity can be tested in place.

The 1415 detector is built of plug-in construction and plugs into the same base as the 2451 Series photoelectric smoke detectors, making both models interchangeable. The bases are available for two-wire, four-wire, and 120 VAC four wire operation.

Two visible LEDs on each detector flash approximately every ten seconds indicating that power is being applied to the detector. The LEDs light steadily when the detector is in alarm. A remote LED annunciator is available as an optional accessory.

The 1415 detector is Listed for use inside ducts up to a velocity of 1,200 FPM.

Sensitivity testing is performed by placing a test magnet against the cover. The LED on the detector should light within 5 seconds.

Field metering of detector sensitivity may be performed with the aid of a voltmeter and Test Kit, MOD 400R.

Specifications

Nominal Sensitivity:	1.5 %/ft
Operating Voltage:	8.5 - 35 VDC (24 VDC nominal)
Operating Temperature:	32° to 120° F (0° to 49° C)
Operating Humidity:	10 % - 93 % relative humidity
Air Velocity:	1,200 FPM
Altitude:	10,000 ft.
Construction:	Off-white flame retardant plastic
Diameter:	6.2 inches (15.7 cm)
Height:	3.2 inches (8.1 cm)
Weight:	0.5 lb (277 g)

System Sensor Ionization Smoke Detector



1415

Features

- Uses a unique dual unipolar sensor that provides exceptional stability
- Offers an easy plug-in of the head to base
- Provides the following built-in features:
 - Tamper-resistant
 - Test switch
 - Visual alarm indicators
- Displays a 360° view angle of alarm LEDs
- Compatible with the Gamewell-FCI fire alarm control panels
- Performs field adjustable sensitivity and field metering of detector sensitivity
- Furnishes insect-resistant screening (.020"/.508 mm openings)
- Includes a removable insect screen and cover for field cleaning
- Sealed against dirt, insects, and back pressure

An ISO 9000-2000 Company



GAMEWELL-FCI

12 Clintonville Road, Northford, CT 06472-1610 USA • Tel: (203) 484-7161 • Fax: (203) 484-7118

Specifications are for information only, are not intended for installation purposes, and are subject to change without notice. No responsibility is assumed by Gamewell-FCI for their use.

Mounting

- On a 4 inch square box with or without plaster ring or supplied adapter. Minimum depth 1.5 inches
- On a 3.5 or 4 inch octagonal box. Minimum depth 1.5 inches
- On a single gang box. Min. depth 1.5 inches

Installation

Place the detector into the detector base. Turn the detector clockwise until the detector locks into place.

To use the tamper-proof feature, break the smaller tab on the scribed line in the tamper proof tab located on the detector mounting bracket. Install the detector. To remove the detector from the base when using the tamper-proof feature, insert the blade of a small screwdriver into the hole on the side of the base and push the plastic lever away from the detector head. This will allow the detector to be rotated counterclockwise for removal.

Note: The decorative ring must be removed in order to remove the head when using the tamper-proof feature.

The tamper-proof feature may be defeated permanently by breaking the plastic lever off the base

Note: The number of two-wire smoke detectors which can be accommodated per zone varies with different control panels. Consult the control panel instruction manual to determine the capacity.

Refer to NFPA 72, Chapter 5-3, "Smoke Sensing Fire Detectors" for spacing, location of detectors and other guidelines.

Testing

Detectors may be tested in the following ways:

- Place a test magnet against the cover opposite the test module socket. (See illustration). The detector should go into alarm within 5 seconds.
- Field metering of detector sensitivity may be performed with the aid of a voltmeter and Test Kit MOD 400R. For the complete procedure, refer to the Installation and Maintenance Instructions furnished with each detector.

Maintenance

Cleaning programs should be adapted to the individual environment. We recommend at least, an annual cleaning of the unit. The detector screen and cover assembly can be removed, revealing the sensing chamber. A vacuum cleaner can be used to remove dust from the screen, cover and sensing chamber. For the complete procedure, refer to the Installation and Maintenance Instructions furnished with each detector.

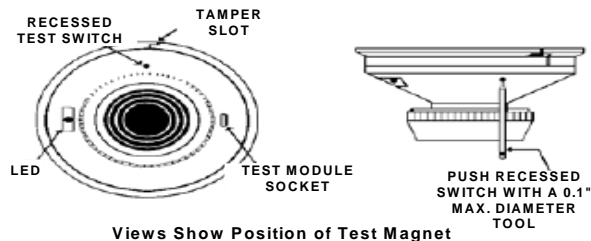

Views Show Position of Test Magnet

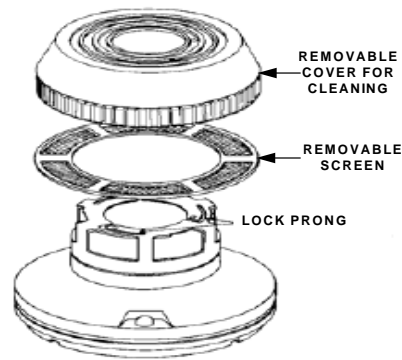

Figure 1

WARNING: To prevent detector contamination during construction, smoke detectors must be protected from dust and contamination until the area is clean and dust free. see NFPA 72 -5-3.7.1.3.

Ordering Information

Part Number	Description
1451	Ionization Detector
Alarm Current	‡
B401B	Base, two-wire
Supervisory Current	00012 A
Alarm Current	‡
B402B	Base, four-wire, 24 VDC operation
Supervisory Current	.00012 A
Current	.036 A
Contacts	Form A, C*
B404B	Base, four-wire, 120 VAC operation
Contacts	Form A, C* & Supervisory
RA-400	Remote alarm indicator
Alarm Current	.007 A
PAM-1	End-of-line relay, 24 VDC
Alarm Current	.015 A
Contacts	Form B Test kit
*Resistive load (Contact Ratings):	Form A - 2.0 A @ 30 VAC/DC Form C - 2.0 A @ 30 VAC/DC, 1.0 A @ 120 VAC

‡Note: Alarm current of detector is limited by control panel initiating device circuit.

GAMEWELL-FCI

12 Clintonville Road, Northford, CT 06472-1610 USA • Tel: (203) 484-7161 • Fax: (203) 484-7118
9020-0584 Rev. C page 2 of 2

www.gamewell-fci.com