

Wireless Top Mounted Ultrasonic Liquid Level Sensor R718PE Data Sheet

Wireless Sensor Network Based on LoRa Technology



Copyright©Netvox Technology Co., Ltd.

This document contains proprietary technical information which is the property of NETVOX Technology. It shall be maintained in strict confidence and shall not be disclosed to other parties, in whole or in part, without written permission of NETVOX Technology. The specifications are subject to change without prior notice.

Product introduction

R718PE is a wireless communication device that uses ultrasound to detect the distance between the device and the detected object. The medium the device detects is the air, so the detected object can be any liquid or solid that has a flat and horizontal surface, water level for example.

The main body and the sensor of R718PE communicates via the UART serial port, and the detected data can be transmitted via LoRa™ communication.

Device working principle

There is LoRa module R100H/R100L in the main body of R718PE and the module communicates with the ultrasonic sensor via UART serial port.

The working principle for the ultrasonic sensor is as follows. There are emitter and receiver on the ultrasonic sensor. The ultrasonic sensor will emit ultrasound and measure the distance based on how much time it takes for the echo signal reflected back to the receiver (the ultrasonic sensor will start to time at the moment the ultrasound is emitted.) As the medium is the air and the speed of the ultrasound in air is 340m/s, the distance (S) between the detected object and the sensor can be calculated with the time

(t ,unit :second)counted by the sensor. $S=340*t / 2$

Wireless Top Mounted Ultrasonic Liquid Level Sensor

Main characteristics

- Adopt SX1276 wireless communication module
- 2 ER14505 battery in parallel power supply(AA SIZE 3.6V/section)
- The main body of R718PE is IP65 / IP67(optional), and the ultrasonic sensor is IP67
- UART Serial communication
- The base is attached with a magnet that can be attached to a ferromagnetic material object
- Compatible with LoRaWAN™ Class A
- Frequency-hopping spread spectrum technology, FHSS
- Configuration parameters can be configured via a third-party software platform, data can be read and alerts can be set via SMS text and email (optional)
- Applicable to third-party platforms: Actility / ThingPark / TTN / MyDevices / Cayenne

Application scenario

- Water level monitoring of water tank
- Water level monitoring of water well
- Detect horizontal surface distance value
- Solid object level detection
- Others

Dimensions

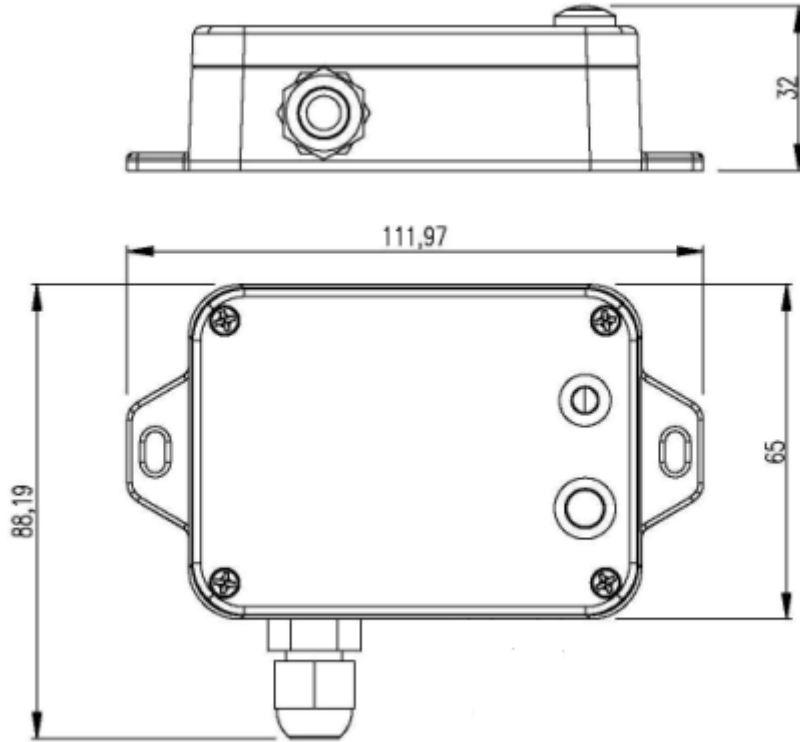

Electrical characteristics

Power supply	2 ER14505 lithium batteries (3.6 V, 2400 mAh / section) in parallel
Battery life	Battery life is 2.9 years (condition: ambient temperature 25°C, reports once every 15 minutes, txpower = 20 dBm, LoRa spreading factor SF = 10)
Standby current	20 uA
Wake-up current	7.3mA @3.3V
Low battery alarm	3.2V
RF receiving current	11 mA @3.3V
RF emission current	120mA @3.3 V

* Electrical characteristics may vary depending on the battery voltage

Wireless Top Mounted Ultrasonic Liquid Level Sensor

Ultrasonic ranging sensor

Power supply	DC 3.3V~5V
Working current	Less than 15mA
Measuring range	0.25-8m
Blind distance	0-0.25m
Detection angle	15°
Measurement accuracy	$\pm(1+S*0.3\%) \text{ cm}$ (S is the detected distance between the device and the detected liquid/solid)

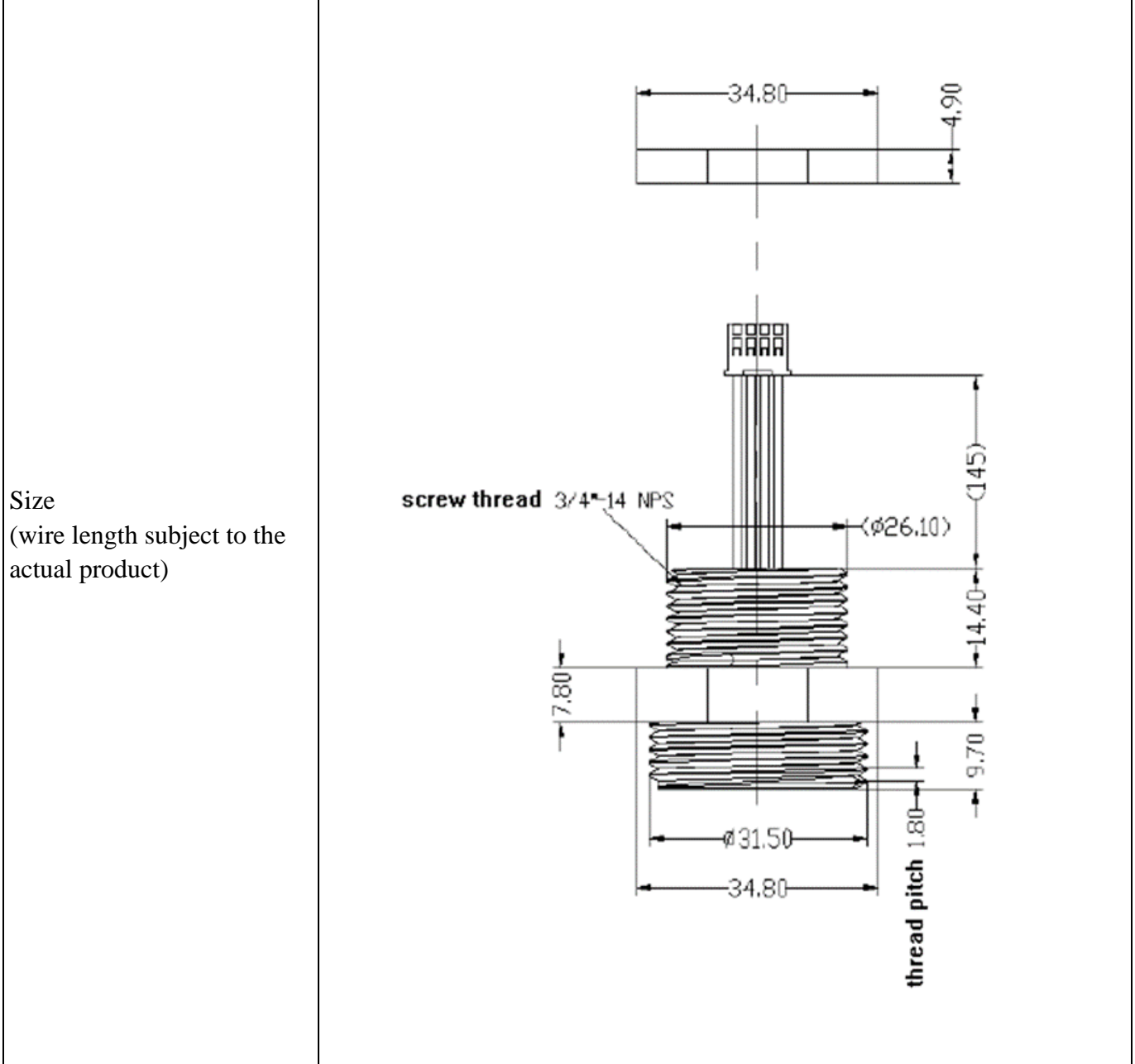

Wireless Top Mounted Ultrasonic Liquid Level Sensor

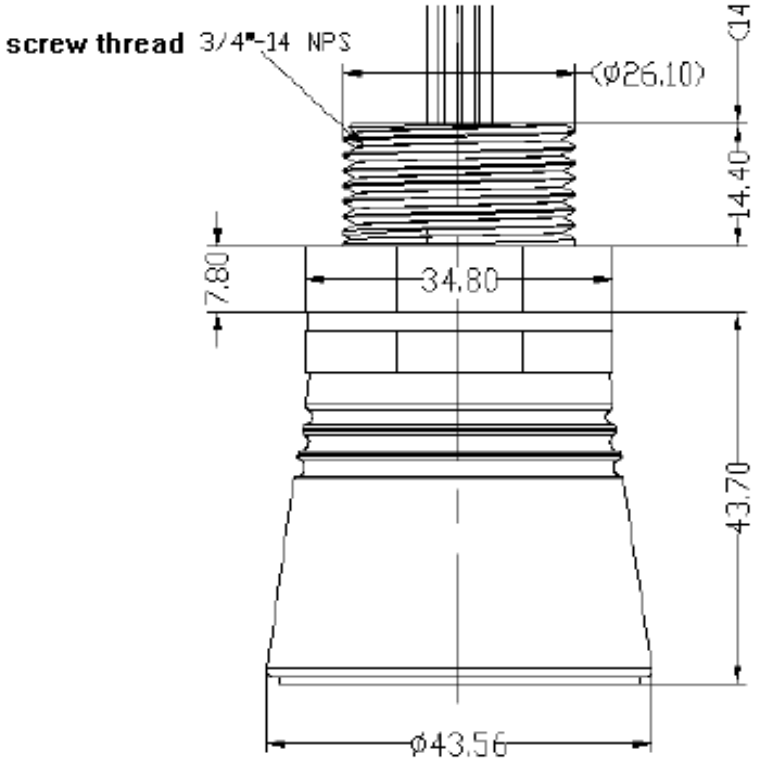
	 <p>Technical drawing of the R718PE sensor showing dimensions:</p> <ul style="list-style-type: none"> Screw thread: 3/4"-14 NPS Top diameter: $\phi 26.10$ Thread length: 14.40 Flange thickness: 7.80 Flange diameter: 34.80 Total height: 43.70 Bottom diameter: $\phi 43.56$
Operating temperature	-15°C ~ 55°C
Operating humidity	<80% RH
Installation	Top mounted

Radio frequency characteristics

Frequency range	863MHz-928MHz 470MHz-510MHz
Power output	US915 20dbm; AS923 16dbm; AU915 20dbm; CN470 19.15dbm; EU868 16dbm; KR920 14dbm; IN865 20dbm;
Receiving sensitivity	-136dBm (LoRa, Spreading Factor=12, Bit Rate = 293bps); -121 dBm (FSK, Frequency deviation=5kHz, Bit Rate=1.2kbps)
Antenna type	Built-in antenna
Communication distance	Up to 10 km, the actual transmission distance depends on the real environment.

Wireless Top Mounted Ultrasonic Liquid Level Sensor

Data transfer rate	0.3kbps to 50kbps
Modulation system mode	LoRa/FSK (Note: choose one of them)
Supportable LoRaWAN band	EU863-870, US902-928, AU915-928, KR920-923, AS923, CN470-510 (Note: The frequency band is optional and needs to be configured before the shipment)

Physical characteristics

Size	L:112mm*W:88.19mm*H:32mm
Ambient temperature range	-15°C ~ 55°C
Body weight	0.24 kg (include battery)
Operating humidity range	<90% RH (no condense)
Storage temperature range	-25°C ~ 70°C