

# HE30XD2/HE30XD2G/HE41XD2

TDN 1080p IR Ball Camera







OPERATIONAL	
VIDEO STANDARD	NTSC/PAL
SCANNING SYSTEM	Progressive scan
IMAGE SENSOR	1/2.9" 2 MP CMOS
NUMBER OF PIXELS (H × V)	1920 × 1080
MINIMUM ILLUMINATION	HE30XD2: 0.02 lux colour @ F2.0, 0 lux B/W with IR LEDs on @ F2.0 HE30XD2G: 0.02 lux colour @ F2.0, 0 lux B/W with IR LEDs on @ F2.0 HE41XD2: 0.02 lux colour @ F1.4, 0 lux B/W with IR LEDs on @ F1.4
S/N RATIO	> 65 dB
ELECTRONIC SHUTTER SPEED	NTSC: 1/30 – 1/100,000 s PAL: 1/25 – 1/100,000 s
RESOLUTION	1080p (1920 × 1080)
FRAME RATE	25/30 fps @ 1080p 25/30/50/60 fps @ 720p
VIDEO OUTPUT	1-channel BNC CVI/TVI/AHD/CVBS video output
IR DISTANCE	HE30XD2/HE30XD2G: Up to 40 m (120 ft.), depending on scene reflectance HE41XD2: Up to 30 m (98 ft.), depending on scene reflectance
NUMBER OF IR LEDs	HE30XD2/HE30XD2G: 1 High Power IR LED HE41XD2: 20 IR LEDs
SMART IR	Auto/Manual
DAY/NIGHT	Auto (ICR)/Manual
BACKLIGHT COMPENSATION	BLC/HLC/DWDR
WHITE BALANCE	Auto/Manual
GAIN CONTROL	AGC
WIDE DYNAMIC RANGE	DWDR
NOISE REDUCTION	2DNR
PRIVACY MASKING	Up to 8 configurable areas
LENS	HE30XD2/HE30XD2G: 3.6 mm, fixed lens, F2.0 HE41XD2: 2.7 – 13.5 mm, vari-focal lens, F1.4
HORIZONTAL ANGLE OF VIEW	HE30XD2/HE30XD2G: 82.8° HE41XD2: 96° ~ 33°
AUDIO	N/A

ELECTRICAL	
POWER SUPPLY	12 VDC ±25%
POWER CONSUMPTION	HE30XD2/HE30XD2G: 2.9 W max. (IR LEDs on) HE41XD2: 4.2 W max. (IR LEDs on)
MECHANICAL	
DIMENSIONS	HE30XD2: Ø106.0 mm × 93.7 mm (Ø4.17" × 3.69") HE30XD2G: Ø106.0 mm × 93.7 mm (Ø4.17" × 3.69") HE41XD2: Ø119.2 mm × 98.8 mm (Ø4.69" × 3.89")
PRODUCT WEIGHT	HE30XD2/HE30XD2G: 0.44 kg (0.97 lb.) HE41XD2: 0.56 kg (1.23 lb.)
PACKAGE WEIGHT	HE30XD2/HE30XD2G: 0.41 kg (0.90 lb.) HE41XD2: 0.69 kg (1.52 lb.)
CONSTRUCTION	Die-cast aluminum housing with powder coat
CONSTRUCTION COLOUR	HE30XD2/HE41XD2: RAL 9003 (White) HE30XD2G: RAL 7022 (Gray)
ENVIRONMENTAL	
OPERATING TEMPERATURE	-40°C to 60°C (-40°F to 140°F)
COLD START	Startup should be done at above -40°C (-40°F)
STORAGE TEMPERATURE	-40°C to 60°C (-40°F to 140°F)
RELATIVE HUMIDITY	Less than 90%, non-condensing
INGRESS PROTECTION	IP66
REGULATORY	
EMISSIONS	EN55032, ANSI C63.4-2014
IMMUNITY	EN50130-4
SAFETY	EU: EN60950-1
ROHS	EN50581

# TDN 1080p IR Ball Cameras

## RECOMMENDED ACCESSORIES

SYSTEM COMPATIBILITY		HOUSING AND MOUNTS	
HRHQ104* HQA DVRS	4-channel, 720p@120/100 fps, 1080p@60/50 fps, 1 SATA, alarm I/O	HQA-WK	 Wall Mount Adapter
HRHQ108* HQA DVRS	8-channel, 720p@240/200 fps, 1080p@120/100 fps, 2 SATA, alarm I/O	HQA-PM2**	 Pole Mount Adapter
HRHQ116* HQA DVRS	16-channel, 720p@480/400 fps, 1080p@240/200 fps, 2 SATA, alarm I/O	HQA-BB3	 Junction Box (Off-White), HE30XD2 and HE41XD2 only
		HQA-BB3G	 Junction Box (Gray), HE30XD2G only

\* Pre-installed storage (TB).

\*\* The HQA-BB3 or HQA-BB3G junction box must be used when installing the camera to HQA-PM2.

## ORDERING

HE30XD2	TDN 1080p IR Ball Camera, 1/2.9" 2 MP CMOS, 3.6 mm Fixed Lens, 1 High Power IR LEDs, 12 VDC, IP66, Off-White
HE30XD2G	TDN 1080p IR Ball Camera, 1/2.9" 2 MP CMOS, 3.6 mm Fixed Lens, 1 High Power IR LEDs, 12 VDC, IP66, Gray
HE41XD2	TDN 1080p IR Ball Camera, 1/2.9" 2 MP CMOS, 2.7–13.5 mm Vari-focal Lens, 20 IR LEDs, 12 VDC, IP66, Off-White

## DIMENSIONS

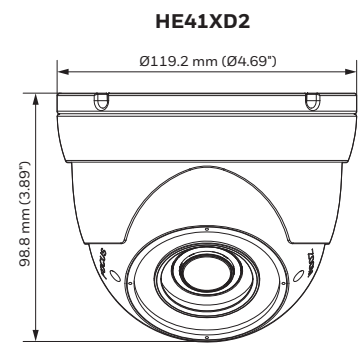
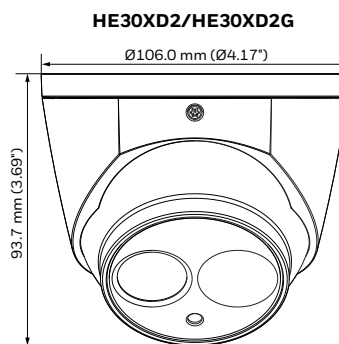

### For more information

[www.honeywell.com/security](http://www.honeywell.com/security)

### Honeywell Security and Fire

Aston Fields Road  
Whitehouse Industrial Estate  
Runcorn, Cheshire, WA7 3DL  
United Kingdom  
Tel: +44 (0)8448 000 235  
[www.honeywell.com](http://www.honeywell.com)

### Honeywell Security Office -

Emaar Business Park, Sheikh Zayed Road  
Building No. 2, 2nd floor, 201  
Post Office Box 232362  
Dubai, United Arab Emirates  
Tel: +971 44541704  
[www.honeywell.com](http://www.honeywell.com)

Honeywell reserves the right, without notification, to make changes in product design or specifications.

HSFV-HE30XD2D-01-UK(1117)DS-E  
November 2017  
© 2017 Honeywell International Inc.

**Honeywell**