

C7110C1040 and C7110C1080 WALL MODULES

PRODUCT DATA



MODELS

order no.	description
C7110C1040	<ul style="list-style-type: none"> • 0...10 VDC CO₂ sensor output • PT1000 temp. sensor (passive) • Service LED (accessible after lifting cover)
C7110C1080	<ul style="list-style-type: none"> • 0...10 VDC CO₂ sensor output • NTC20kΩ temp. sensor (passive) • Service LED and Occupancy Bypass Button (accessible after lifting cover)

DIMENSIONS

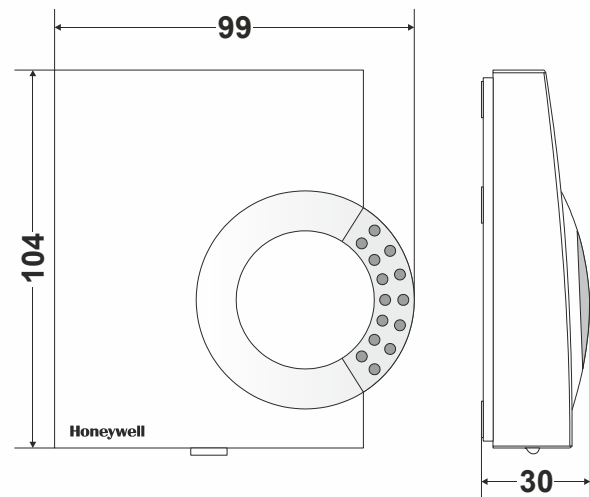

Fig. 1. Dimensions in mm

GENERAL

The C7110C1040 and C7110C1080 are combined CO₂ / passive temperature wall modules designed for applications in indoor ventilation and air conditioning systems. In conjunction with the Honeywell controllers, they can be used to control the flow of incoming air, thus improving air quality while reducing energy consumption. During high-occupancy periods, air can be supplied to rooms in order to maintain the desired air quality, while during low-occupancy periods, the unnecessary conditioning of air can be avoided or reduced.

FEATURES

- Fully compatible with the Honeywell controllers.
- CO₂ sensor employing state-of-the-art Non-Dispersion Infrared (NDIR) technology.
- Selectable CO₂ measurement range of 400...2000/3000 ppm.
- Self-calibrating: automatic drift correction (ABC algorithm) based on long-term evaluation.
- Internal Service LED (visible after removing cover).

TECHNICAL DATA

General

Power supply (terminals 1+3)	24 VAC ± 20%; 50/60 Hz or 24 VDC ± 30%; 1.5 W
Power-up time	≤ 60 sec (incl. self-diagnostics)
Ambient operating limits	0...50 °C, 0...95% rh, non-cond.
Storage limits	-40...+70 °C, 0...95% rh, non-cond.
Sensor life expectancy	> 15 years, maintenance-free

Classification according to EN 60730-1

EN 60730 sub part	EN 60730-2-9
Environmental conditions	For use in residential, commercial, and light-industrial environment
Pollution degree	Class 2
Protection against shock	Class III
Software class	A
Automatic action	Type 1 action

Classification according to EN 60529

Degree of protection provided by enclosures	IP20
---	------

CO2 Measurement

Range	400...2000 / ...3000 ppm
Output (terminals 1-2)	0...10 VDC for max. ±2 mA
Accuracy	factory-calibration ±50 ppm or ±5% of measurement range
Pressure dependence	+1.6% per kPa deviation from normal pressure of 100 kPa
Response time	90% penetration within 2 min

MOUNTING

WARNING

Risk of electric shock or equipment damage!

- ▶ Do not touch any live parts.
- ▶ Disconnect power supply before making connections.
- ▶ Do not reconnect power until installation is complete.
- ▶ Observe precautions for handling electrostatic sensitive devices.



1. Remove the cover (see Fig. 2).
2. Mount the socket onto the wall approx. 1.5 meters above the floor.
3. Connect the wires to the terminals. Do not connect the power supply until all connections and settings have been correctly completed.
4. Remount the cover.

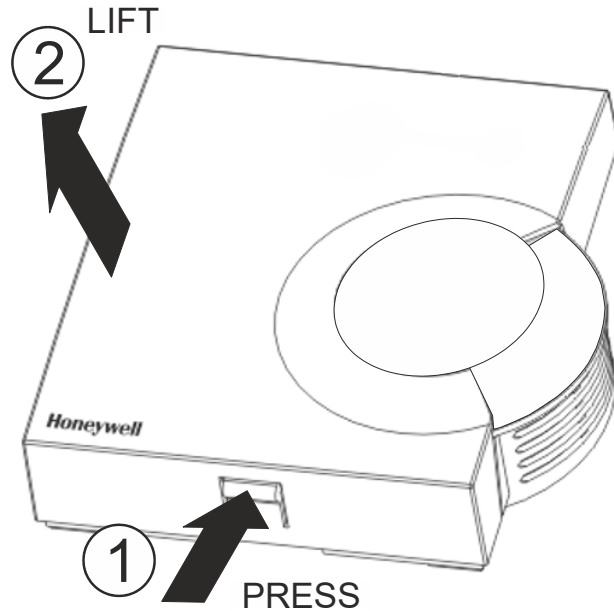

Fig. 2. Removing the cover

WIRING

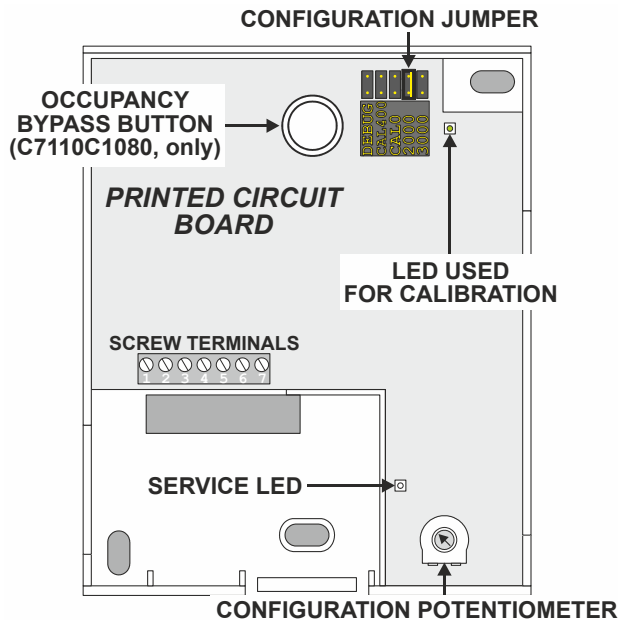

Fig. 3. PCB, main features

The screw terminals, located on the Printed Circuit Board (see Fig. 3), are suitable for connecting 0.3 to 1.5 mm² (16...22 AWG) wiring. The assignments of terminals 1 through 7 for both models are depicted in Fig. 4.

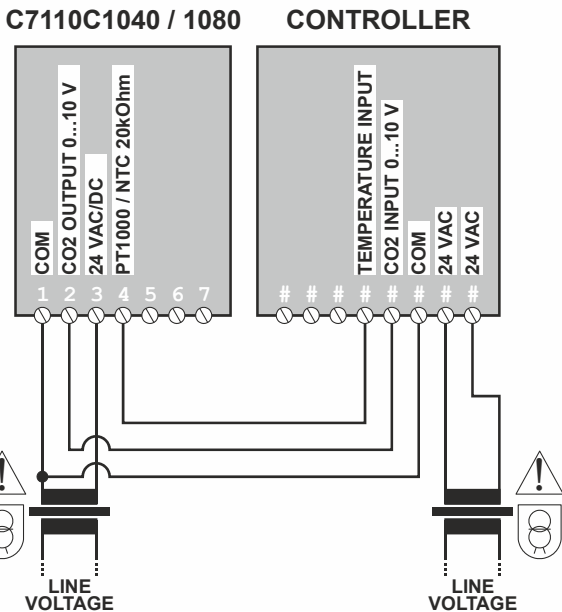

Fig. 4. Wiring C7110C1040 / 1080 to controller and separate safety transformer

CONFIGURATION

The wall module can be configured using its configuration jumper and/or its configuration potentiometer.

Configuration Jumper

The wall module's calibration modes can be selected and the CO₂ measuring range extended by repositioning the configuration jumper located on the Printed Circuit Board (see Fig. 3).

IMPORTANT

Do not change the position of the configuration jumper before first removing power.

In a normal environment, the unit is maintenance-free. Accurate measurement is guaranteed by the built-in ABC self-calibration feature (see below).

Setting Range to 2000 ppm or 3000 ppm

"2000" ppm

When the configuration jumper is set to the factory default position of "2000" ppm (see Fig. 8) – or to any other position **except** "3000" ppm (see Fig. 5) – the CO₂ measuring range is 400...2000 ppm.

"3000" ppm

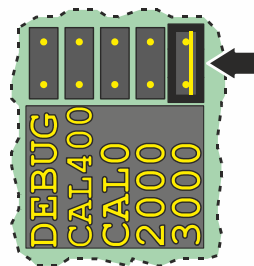

Fig. 5. Jumper set to 3000 ppm

When the configuration jumper is set to position "3000" ppm (see Fig. 5), the CO₂ measuring range will be expanded to 400...3000 ppm.

Quick Calibration Methods

In the event that one cannot wait for ABC to gradually correct measurement errors, it is possible to make use of either one of the following two quick calibration methods:

- Zero Calibration or
- Fast Background Calibration (recommended method).

These quick calibration methods typically take about 2 minutes.

IMPORTANT

Do not change the position of the configuration jumper before first removing power.

After initiating the desired calibration process by removing power and then repositioning the jumper, restore power and then wait until the calibration process has been completed (see "Behavior of Service LED during Quick Calibration") before again removing power, returning the jumper to the desired range setting (i.e., "2000" or "3000"), and finally restoring power.

Zero Calibration ("CAL0")

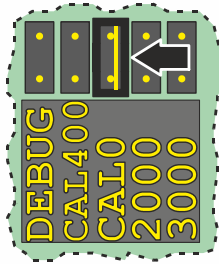

Fig. 6. Jumper set to CAL0

When the configuration jumper is set to position "CAL0" (see Fig. 6), Zero Calibration will be carried out. This is done while testing the wall module with CO₂-free air (e.g., a pure nitrogen atmosphere or air purged of CO₂ using Milk of Lime).

Fast Background Calibration ("CAL400")

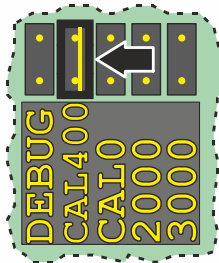

Fig. 7. Jumper set to CAL400

When the configuration jumper is set to position "CAL400" (see Fig. 7), Fast Background Calibration will be carried out. The current level is then set to 400 ppm (= normal expected actual fresh air level) in a single step.

NOTE: Before starting Fast Background Calibration, ventilate the room with fresh outdoor air.

Behavior of Service LED during Quick Calibration

During Zero Calibration or Fast Background Calibration, the Service LED will indicate that the given calibration process is in progress by flashing once per second for 90 sec (sensor warm-up) and then twice per second for 10 sec (sensor calibration). Once the calibration process has been completed, however, the Service LED will then stop flashing and return to normal operational behavior.

NOTE: One possible reason for a failed calibration is if CO₂ levels fluctuate too wildly during calibration; in this event, you should remove and then restore power to the device and perform the calibration again.

ABC

During **ABC (Automatic Baseline Correction)** – which is **ON** by default – any initial (due, e.g., to rough handling during shipping) or subsequent long-term drift will be gradually corrected (i.e., by a max. of 50 ppm per week). This is done by comparing the lowest measured value (over the last 7.5 days) with the expected fresh air level (400 ppm).

When the configuration jumper is set to the factory default position of "2000" ppm or to "3000" ppm, the wall module will operate normally and perform ABC.

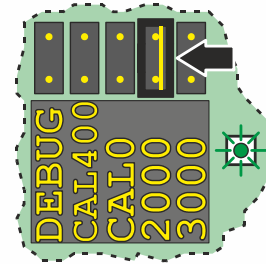

Fig. 8. Default setting (ABC ON = adjacent LED flashes GREEN for first 10 s after power restoration)

NOTE: In buildings featuring plastered walls / ceilings or other constructional materials containing quicklime – especially when fresh – unusually low levels of CO₂ (i.e., far below 400 ppm) may prevail, especially in new, poorly ventilated areas. To prevent sensor malfunctions in such situations, it is recommended that ABC be switched **OFF**.

Switching ABC OFF and ON

IMPORTANT

Do not change the position of the configuration jumper before first removing power.

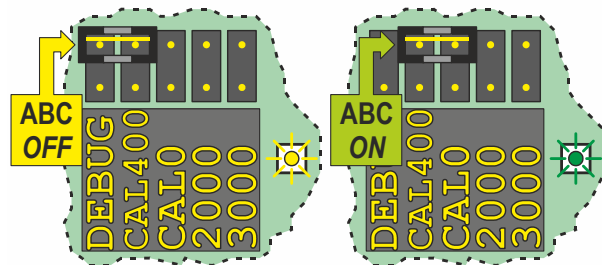

Fig. 9. Switching ABC OFF (left) or ON (right)

ABC can be switched **OFF** by repositioning the jumper as indicated in the left-hand side of Fig. 9. The adjacent LED will then flash **YELLOW** briefly and then remain lit **YELLOW**. This indicates that ABC has finished switching **OFF**.

NOTE: If ABC is switched **OFF**, we recommend that you then calibrate the sensor using Zero Calibration or Background Calibration at least once per year to ensure that the CO₂ level readings remain within specifications.

ABC can be switched **ON** by repositioning the jumper as indicated in the right-hand side of Fig. 9. The adjacent LED will then flash **GREEN** for the first 10 sec and then remain lit **GREEN**. This indicates that ABC has finished switching **ON**.

NOTE: Only after ABC has finished switching **ON** or **OFF** should you again remove power, return the jumper to the desired range setting (i.e., "2000" or "3000"), and finally restore power. The given ABC setting (**ON** or **OFF**) will then remain in effect even if power is subsequently removed or restored.

"DEBUG"

Fig. 10. Do not set jumper set to DEBUG!

DO NOT USE!

Configuration Potentiometer

The wall module features a configuration potentiometer (accessible only after removing the top cover) which can be used to configure the output of terminal 2 (CO₂ level) and (when in the "Relay Output" mode) the "Threshold Level (ppm)".

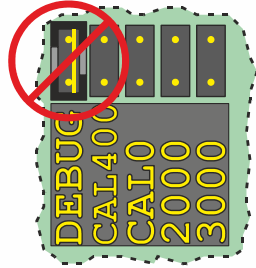
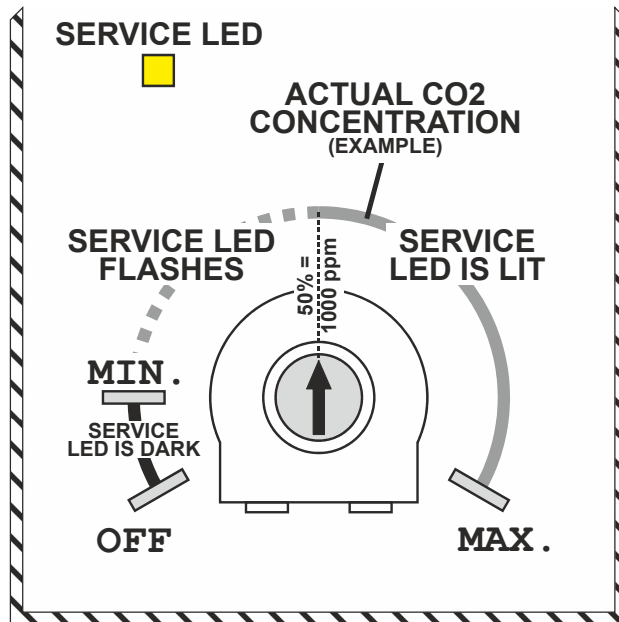

Fig. 11. Configuration potentiometer (e.g., set to 50% = 1000 ppm)

The CO₂ output can operate in two modes:

- To select the "Sensor Output" mode (analog), set the configuration potentiometer to "OFF" (default setting) (see Fig. 11). See also Fig. 12.
- To select the "Relay Output" mode (digital), set the configuration potentiometer to between the "MIN." and "MAX." markers (see Fig. 11). The hysteresis value is permanently set to 100 ppm. See also Fig. 13.

The "Sensor Output" Mode

In the "Sensor Output" mode (analog), the Service LED (see Fig. 11) is always dark.

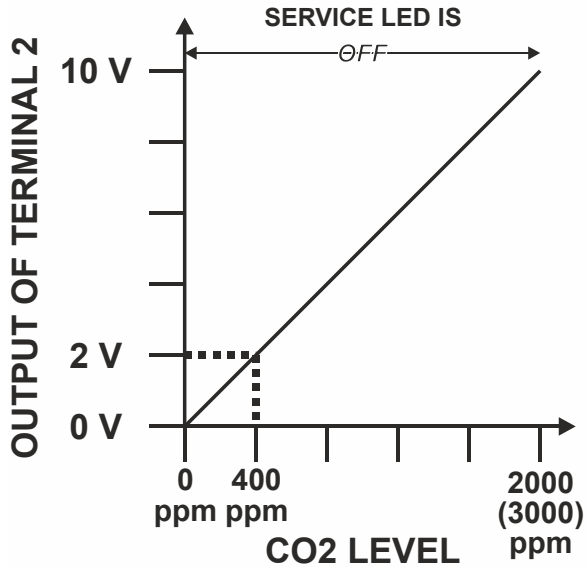

Fig. 12. Sensor output mode (analog)

In the "Sensor Output" mode (analog), terminal 2 delivers an analog output of 0...10 V. You can then configure a measuring range of either 400 to 2000 ppm or 400 to 3000 ppm, depending upon the position of the configuration jumper. Due to ABC calibration to 400 ppm, given measured concentrations below 400 ppm, the output signal will gradually rise to 2 V.

The "Relay Output" Mode

In the "Relay Output" mode (digital), the Service LED (see Fig. 11) will either flash or be lit continuously, thus indicating the actual Threshold Level setting.

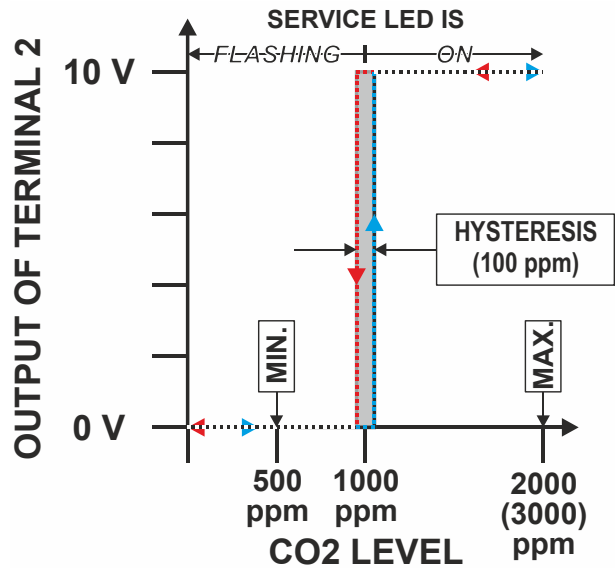

Fig. 13. Relay output mode (digital)

In the "Relay Output" mode (digital), terminal 2 delivers digital output (of 0 / 10 V). You can then configure a "Threshold Level (ppm)" of any value between MIN. = 500 and MAX. = 2000 (or 3000, if configuration jumper is in "3000 ppm") by turning the configuration potentiometer (in the above example, the Threshold Level has been set to 1000 ppm).

LED BEHAVIORS AND MEANINGS

Table 1. Service-LED behaviors and their meanings

service LED	modes	remarks
1 flash / sec for 90 sec	"Sensor Output" (S.O.) + "Relay Output" (R.O.) modes	Calibration warm-up
2 flashes / sec for 10 sec	S.O. + R.O.	Calibration in progress
Dark	S.O.	Calibration successful
Lit continuously	S.O.	Calibration failed
Dark	S.O.	CO2 < 1000 ppm
Dark	S.O.	CO2 > 1000 ppm
Flashing	R.O.	CO2 < threshold
Lit continuously	R.O.	CO2 > threshold
--	S.O. + R.O.	ABC <i>ON</i>
--	S.O. + R.O.	ABC <i>OFF</i>

OCC. BYPASS BUTTON (C7110C1080, ONLY) AND CALIBRATION LED

The functionality of the occupancy bypass button (C7110C1080, only) and the corresponding behavior of the calibration LED are dependent upon the programming of the connected controller. Please refer to the controller's technical literature and/or application.

ACCESSORIES

order no.	description
T7460LONJACK	Module for access to external buses (5-pc. set)

T7460-LONJACK

The T7460-LONJACK (ordered separately) is a small board with a 3.5 mm jack. When mounted to the Printed Circuit Board (see Fig. 14), it provides easy access to external buses.

Order quantity: set of 5 pieces

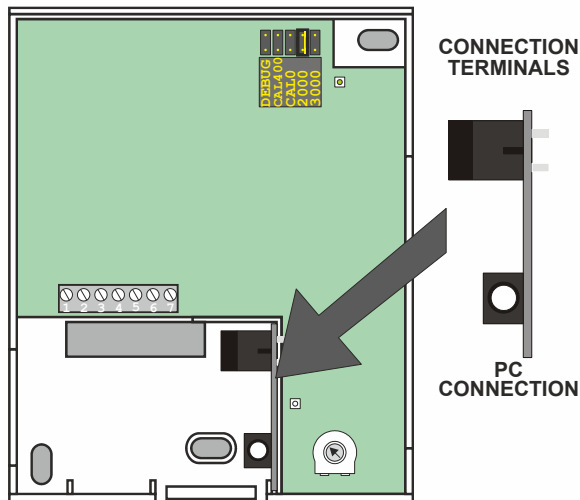

Fig. 14. Mounting the T7460-LONJACK

Honeywell

Manufactured for and on behalf of the Connected Building Division of Honeywell Products and Solutions SARL, Z.A. La Pièce, 16, 1180 Rolle, Switzerland by its Authorized Representative:

Home and Building Technologies

Honeywell GmbH
 Böblinger Strasse 17
 71101 Schönaich, Germany
 Phone +49 (0) 7031 637 01
 Fax +49 (0) 7031 637 740
<http://ecc.emea.honeywell.com>

EN0B-0775GE51 R0619

Subject to change without notice