

SCM-SS

Six-Circuit Addressable Control Module and SYNC-1 Accessory Card

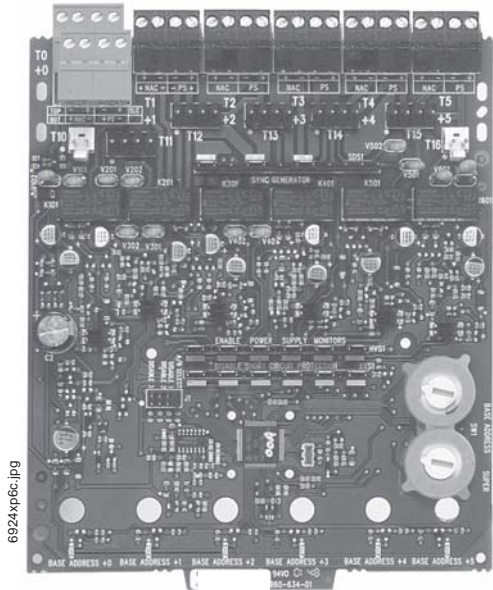

Description

Gamewell's **SCM-SS SmartScan™ six-circuit addressable control module** provides intelligent alarm systems with supervised monitoring of wiring to load devices that require an external power supply to operate, such as horns, strobes, or bells. Each module is intended for switching applications involving AC, DC, or audio, which require wiring supervision. Upon command from the control panel, the SCM-SS will disconnect the supervision and connect the external power supply across the load device.

The first module is addressed from 01 to 94 while the remaining modules are automatically assigned to the next five higher addresses. Provisions are included for disabling a maximum of

three unused addresses. Each SCM-SS module has terminals for connection to an external supply circuit for powering devices on its notification appliance circuit. One or multiple power supplies or amplifiers may be used.

Each SCM-SS module features a short-circuit protection monitor to protect the external power supply against short-circuit conditions on the NAC. When an alarm condition occurs, the relay which connects the external supply to the NAC will not be allowed to close if a short-circuit condition currently exists on the NAC. Additionally, an algorithm is incorporated to find shorts when the module is active. The SCM-SS module will close all circuits that are not shorted to find the NAC with the problem.

Each SCM-SS module has panel-controlled green LED indicators. The panel can cause the LEDs to blink, latch on, or latch off. The **SYNC-1 accessory card** provides the SCM-SS with additional functionality with compatible System Sensor SpectrAlert® audio/visual devices.

SYNC-1 Accessory Card

The SYNC-1 accessory card is designed to operate with the SCM-SS. It works with the SpectrAlert® series of horns, strobes, and horn/strobes to provide a means of synchronizing the temporal-coded horns; synchronizing the one-second flash timing of the strobe; and silencing the horns of the horn/strobe combination over a two-wire circuit while leaving the strobes active. Each SYNC-1 accessory card is capable of synchronizing six Class B circuits or three Class A circuits.

Maximum load on a loop: 3 A.

Operating temperature: 32°F to 120°F (0°C to 49°C).

Wire size: 12 to 18 AWG (3.1 to 0.78 mm²).

Operating voltage range: 11 to 30 VDC FWR, filtered or unfiltered. Refer to notification appliance installation instructions for number of notification appliances and wire size.

Compatible A/V devices: H12/24, HC12/24, MA12/24D, PA400, S12___, S24___, SC24___, P12___, P24___, PC24___, SP2C24___, SP2R24___, SP2W24___, DS2475___.

Refer to device data sheets for model specifications.

Features

- Six supervised addressable Class B or three addressable Class A outputs that function as notification appliance/speaker/telephone circuits.
- Removable 12 AWG (3.1 mm²) to 18 AWG (0.78 mm²) plug-in terminal blocks.
- Status indicators for each point.
- Unused addresses may be disabled.
- Rotary address switches.
- Compatible with Gamewell's 602, 610, 632, 654 and 658 panels with SmartScan™ SLC.
- Optional SYNC-1 accessory card for SpectrAlert® devices.
- Mount one or two modules in a BB-XP cabinet (optional).
- Mount up to six modules on a CHS-6 chassis in a BB-25 cabinet (optional).
- Mounting hardware included.

Listings

Listings and approvals below apply to the SCM-SS Six-Circuit Addressable Control Module and SYNC-1 Accessory Card. In some cases, certain modules may not be listed by certain approval agencies, or listing may be in process. Consult factory for latest listing status.

- UL Listed: file S521.
- CSFM approved: file 7300-1288:169.
- MEA approved: file 368-01-E Vol. II.

Gamewell 
A 150-Year Tradition

Product Line Information

SCM-SS: Six-circuit addressable control module.

SYNC-1: Optional accessory card for notification appliance synchronization.

BB-25: Optional cabinet for up to six modules mounted on CHS-6 chassis (*below*).

Dimensions, DOOR: 24.0" (60.96 cm) wide x 12.632" (32.0852 cm) high, x 1.25" (3.175 cm) deep, hinged at bottom; **BACKBOX:** 24.0" (60.96 cm) wide x 12.550" (31.877 cm) high x 5.218" (13.2537 cm) deep.

CHS-6: Chassis, mounts up to six modules in a BB-25 cabinet.

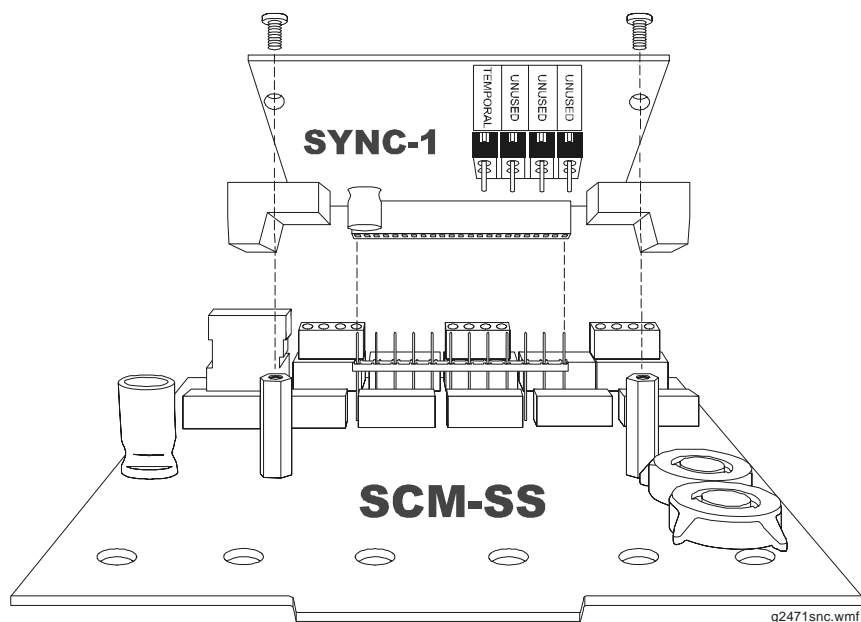

FIGURE 1:
Mounting the SYNC-1 accessory card to the SCM-SS module.

Module setup: Before installing the accessory card on the SCM-SS module, add the shunt to the board where indicated if any horns are required to sound in temporal pattern.

Parts included with SYNC-1: two shunts, four screws, and two standoffs. See installation instructions for details on mounting and wiring the accessory card and module.

Specifications

Standby current

2.25 mA (SLC current draw with all addresses used; if some addresses are disabled, the standby current decreases).

Alarm current

35 mA (assumes all six relays have been switched once and all six LEDs solid ON).

Temperature range

32°F to 120°F (0°C to 49°C) for UL applications.

Humidity

10% to 85% noncondensing for UL applications.

Dimensions

6.8" (172.72 mm) high x 5.8" (147.32 mm) wide x 1.25" (31.75 mm) deep.

Shipping weight

1.1 lb. (0.499 kg) including packaging.

Mounting options

CHS-6 chassis, BB-25 cabinet, BB-XP cabinet, or suitably grounded metallic cabinet.

Wire gauge

12 AWG (3.1 mm²) to 18 AWG (0.78 mm²), grounded.

SCM-SS is shipped in Class B position

Remove shunt for Class A operation.

Maximum NAC wiring resistance

40 ohms.

Power rating per circuit

63 W @ 70.7 VAC (UL applications only); 22.5 W @ 25 VAC.

Relay contact ratings

30 VDC, 110 VAC.

Current ratings

- 3.0 A @ 30 VDC maximum, resistive, non-coded.
- 2.0 A @ 30 VDC maximum, resistive, coded.
- 1.0 A @ 30 VDC maximum, inductive (L/R = 2 ms), coded.
- 0.5 A @ 30 VDC maximum, inductive (L/R = 5 ms), coded.
- 0.9 A @ 70.7 VAC maximum (UL only), resistive, non-coded.
- 0.7 A @ 70.7 VAC maximum (UL only), inductive (PF = 0.35), non-coded.

Compatible devices

Contact Gamewell.

Wiring Diagrams

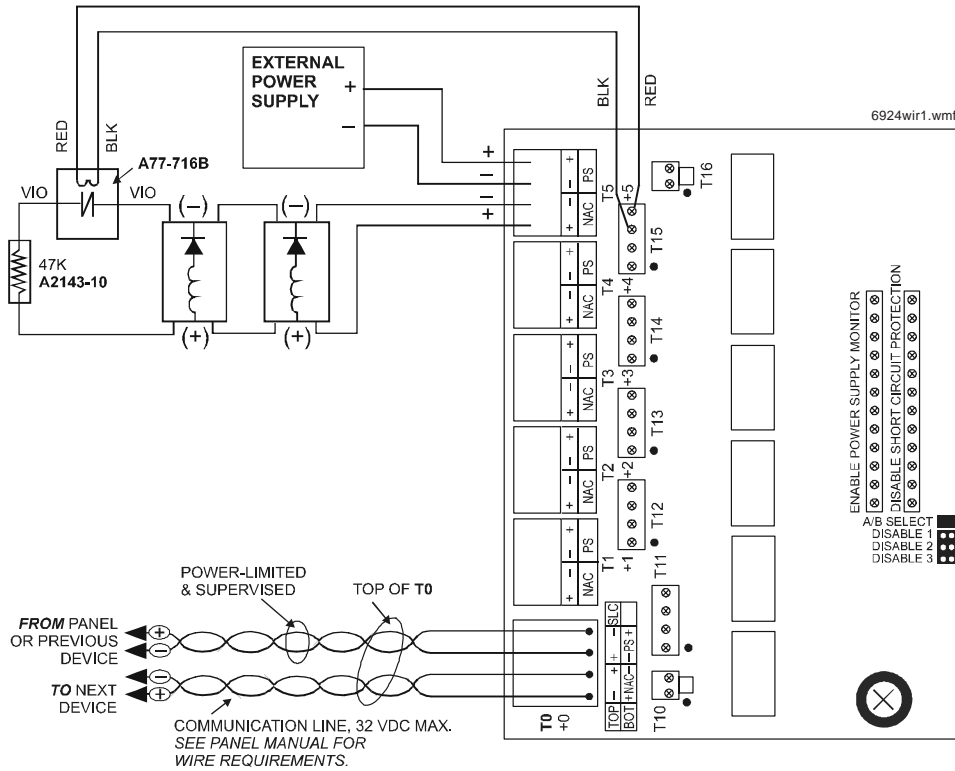

FIGURE 2: Example of Class B, Style Y NAC configuration with a single supply dedicated to a single NAC.

NOTE: EOL relay coil connections must be made using EOL relay connector assemblies on T10 – T16 in event that all NACs on the PCB have dedicated supplies.

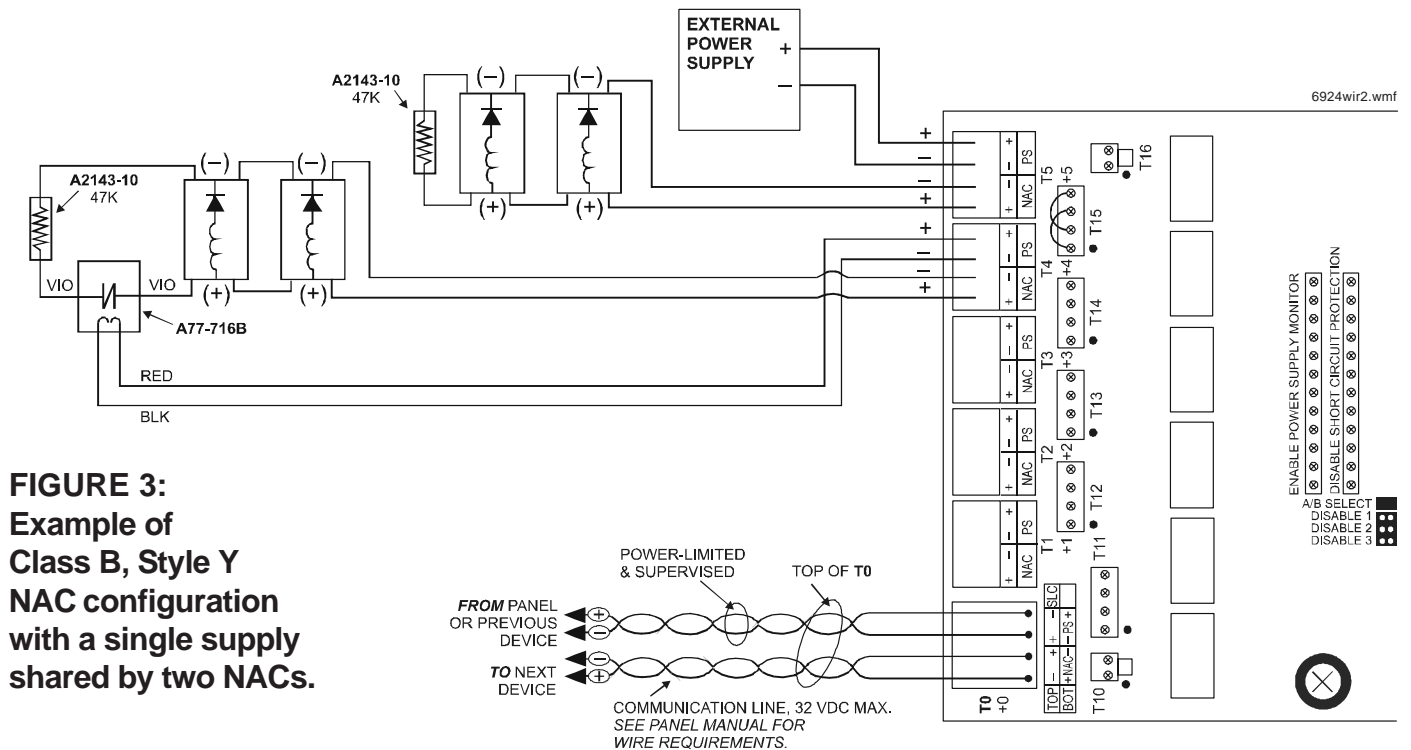

FIGURE 3: Example of Class B, Style Y NAC configuration with a single supply shared by two NACs.

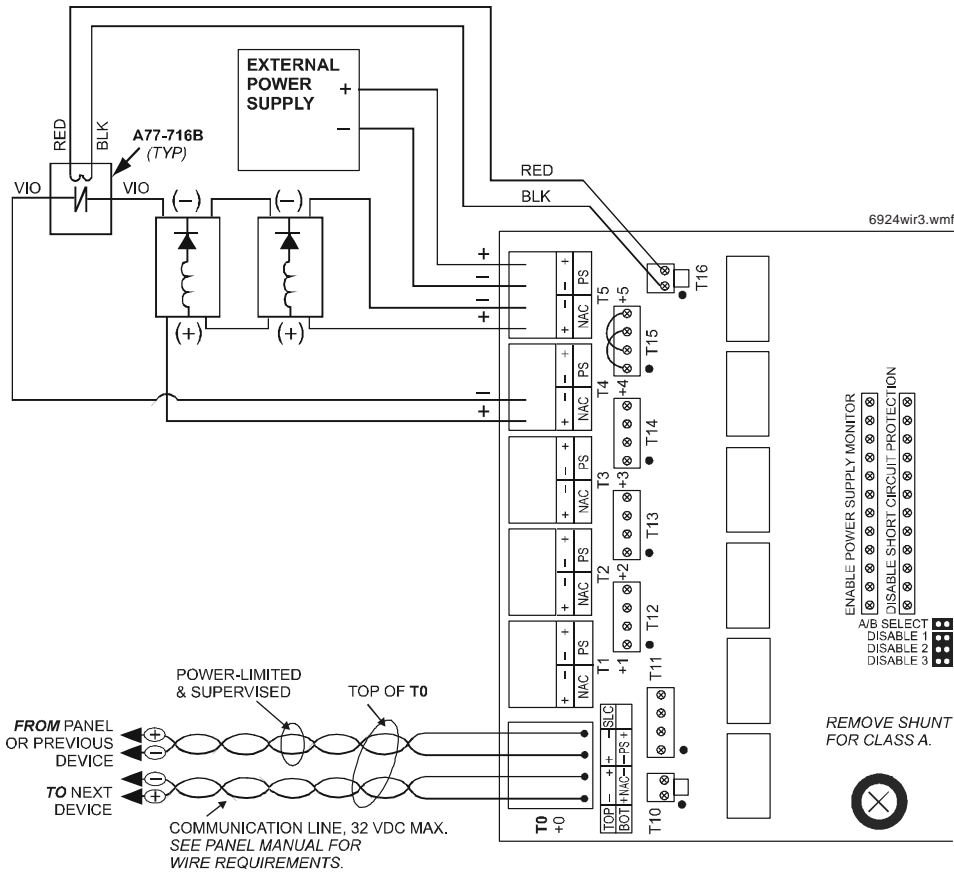

FIGURE 4:
Example of
Class A, Style Z
NAC configuration
with a single supply
dedicated to a
single NAC.

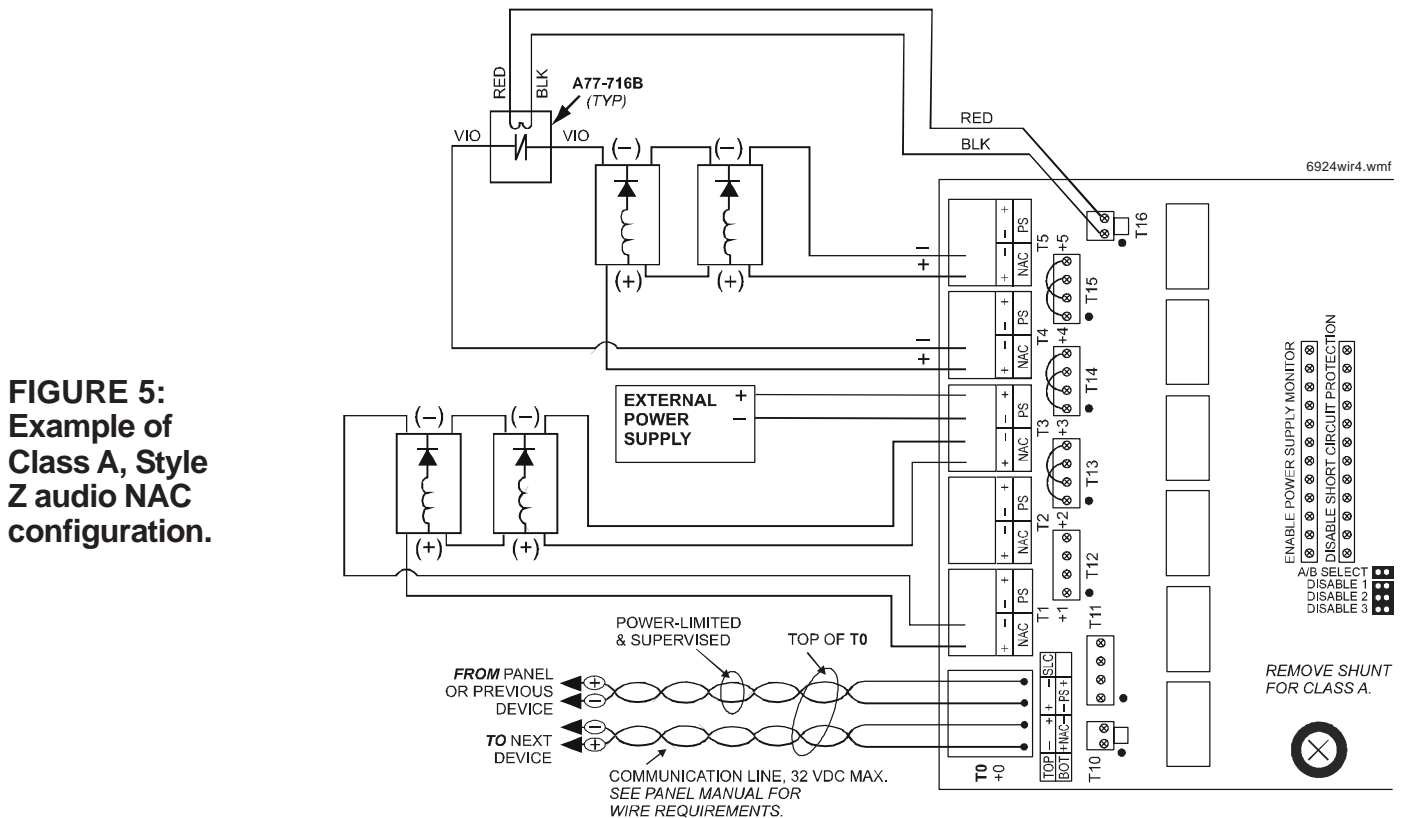

FIGURE 5:
Example of
Class A, Style Z
audio NAC
configuration.



A Honeywell Company

Gamewell-FCI

12 Clintonville Road
Northford, CT 06472-1610
Phone: 203-484-7161
Fax: 203-484-7118
www.gamewell-fci.com

A Honeywell Company
© 2006 Gamewell-FCI

Specifications and wiring information are provided for information only and are believed to be accurate. Gamewell-FCI assumes no responsibility for their use. Data and design are subject to change without notice. Installation and wiring instructions shipped with the product shall always be used for actual installation. For more information, contact Gamewell-FCI.