

# Honeywell



## Remote LCD Display

# GFP-RLD

## Instruction Manual



<http://gamewelfcimanuals.com>

Document LS10310-002GF-E Rev: A  
02/12/2026 ECN: 00068191

# Fire Alarm & Emergency Communication System Limitations

*While a life safety system may lower insurance rates, it is not a substitute for life and property insurance!*

**An automatic fire alarm system**—typically made up of smoke detectors, heat detectors, manual pull stations, audible warning devices, and a fire alarm control panel (FACP) with remote notification capability—can provide early warning of a developing fire. Such a system, however, does not assure protection against property damage or loss of life resulting from a fire.

**An emergency communication system**—typically made up of an automatic fire alarm system (as described above) and a life safety communication system that may include an autonomous control unit (ACU), local operating console (LOC), voice communication, and other various interoperable communication methods—can broadcast a mass notification message. Such a system, however, does not assure protection against property damage or loss of life resulting from a fire or life safety event.

The Manufacturer recommends that smoke and/or heat detectors be located throughout a protected premises following the recommendations of the current edition of the National Fire Protection Association Standard 72 (NFPA 72), manufacturer's recommendations, State and local codes, and the recommendations contained in the Guide for Proper Use of System Smoke Detectors, which is made available at no charge to all installing dealers. This document can be found at <http://www.systemsensor.com/appguides/>. A study by the Federal Emergency Management Agency (an agency of the United States government) indicated that smoke detectors may not go off in as many as 35% of all fires. While fire alarm systems are designed to provide early warning against fire, they do not guarantee warning or protection against fire. A fire alarm system may not provide timely or adequate warning, or simply may not function, for a variety of reasons:

**Smoke detectors** may not sense fire where smoke cannot reach the detectors such as in chimneys, in or behind walls, on roofs, or on the other side of closed doors. Smoke detectors also may not sense a fire on another level or floor of a building. A second-floor detector, for example, may not sense a first-floor or basement fire.

**Particles of combustion or "smoke"** from a developing fire may not reach the sensing chambers of smoke detectors because:

- Barriers such as closed or partially closed doors, walls, chimneys, even wet or humid areas may inhibit particle or smoke flow.
- Smoke particles may become "cold," stratify, and not reach the ceiling or upper walls where detectors are located.
- Smoke particles may be blown away from detectors by air outlets, such as air conditioning vents.
- Smoke particles may be drawn into air returns before reaching the detector.

The amount of "smoke" present may be insufficient to alarm smoke detectors. Smoke detectors are designed to alarm at various levels of smoke density. If such density levels are not created by a developing fire at the location of detectors, the detectors will not go into alarm.

Smoke detectors, even when working properly, have sensing limitations. Detectors that have photoelectronic sensing chambers tend to detect smoldering fires better than flaming fires, which have little visible smoke. Detectors that have ionizing-type sensing chambers tend to detect fast-flaming fires better than smoldering fires. Because fires develop in different ways and are often unpredictable in their growth, neither type of detector is necessarily best and a given type of detector may not provide adequate warning of a fire.

Smoke detectors cannot be expected to provide adequate warning of fires caused by arson, children playing with matches (especially in bedrooms), smoking in bed, and violent explosions (caused by escaping gas, improper storage of flammable materials, etc.).

**Heat detectors** do not sense particles of combustion and alarm only when heat on their sensors increases at a predetermined rate or reaches a predetermined level. Rate-of-rise heat detectors may be subject to reduced sensitivity over time. For this reason, the rate-of-rise feature of each detector should be tested at least once per year by a qualified fire protection specialist. Heat detectors are designed to protect property, not life.

**IMPORTANT! Smoke detectors** must be installed in the same room as the control panel and in rooms used by the system for the connection of alarm transmission wiring, communications, signaling, and/or power. If detectors are not so located, a developing fire may damage the alarm system, compromising its ability to report a fire.

**Audible warning devices such as bells, horns, strobes, speakers and displays** may not alert people if these devices are located on the other side of closed or partly open doors or are located on another floor of a building. Any warning device may fail to alert people with a disability or those who have recently consumed drugs, alcohol, or medication. Please note that:

- An emergency communication system may take priority over a fire alarm system in the event of a life safety emergency.
- Voice messaging systems must be designed to meet intelligibility requirements as defined by NFPA, local codes, and Authorities Having Jurisdiction (AHJ).
- Language and instructional requirements must be clearly disseminated on any local displays.
- Strobes can, under certain circumstances, cause seizures in people with conditions such as epilepsy.
- Studies have shown that certain people, even when they hear a fire alarm signal, do not respond to or comprehend the meaning of the signal. Audible devices, such as horns and bells, can have different tonal patterns and frequencies. It is the property owner's responsibility to conduct fire drills and other training exercises to make people aware of fire alarm signals and instruct them on the proper reaction to alarm signals.
- In rare instances, the sounding of a warning device can cause temporary or permanent hearing loss.

**A life safety system** will not operate without any electrical power. If AC power fails, the system will operate from standby batteries only for a specified time and only if the batteries have been properly maintained and replaced regularly.

**Equipment used in the system** may not be technically compatible with the control panel. It is essential to use only equipment listed for service with your control panel.

## Alarm Signaling Communications:

- **IP connections** rely on available bandwidth, which could be limited if the network is shared by multiple users or if ISP policies impose restrictions on the amount of data transmitted. Service packages must be carefully chosen to ensure that alarm signals will always have available bandwidth. Outages by the ISP for maintenance and upgrades may also inhibit alarm signals. For added protection, a backup cellular connection is recommended.
- **Cellular connections** rely on a strong signal. Signal strength can be adversely affected by the network coverage of the cellular carrier, objects and structural barriers at the installation location. Utilize a cellular carrier that has reliable network coverage where the alarm system is installed. For added protection, utilize an external antenna to boost the signal.
- **Telephone lines** needed to transmit alarm signals from a premise to a central monitoring station may be out of service or temporarily disabled. For added protection against telephone line failure, backup alarm signaling connections are recommended.

**The most common cause** of life safety system malfunction is inadequate maintenance. To keep the entire life safety system in excellent working order, ongoing maintenance is required per the manufacturer's recommendations, and UL and NFPA standards. At a minimum, the requirements of NFPA 72 shall be followed. Environments with large amounts of dust, dirt, or high air velocity require more frequent maintenance. A maintenance agreement should be arranged through the local manufacturer's representative. Maintenance should be scheduled as required by National and/or local fire codes and should be performed by authorized professional life safety system installers only. Adequate written records of all inspections should be kept.

Limit-F-2020

# Installation Precautions

*Adherence to the following will aid in problem-free installation with long-term reliability:*

**WARNING - Several different sources of power can be connected to the fire alarm control panel.** Disconnect all sources of power before servicing. Control unit and associated equipment may be damaged by removing and/or inserting cards, modules, or interconnecting cables while the unit is energized. Do not attempt to install, service, or operate this unit until manuals are read and understood.

**CAUTION - System Re-acceptance Test after Software Changes:**

To ensure proper system operation, this product must be tested in accordance with NFPA 72 after any programming operation or change in site-specific software. Re-acceptance testing is required after any change, addition or deletion of system components, or after any modification, repair or adjustment to system hardware or wiring. All components, circuits, system operations, or software functions known to be affected by a change must be 100% tested. In addition, to ensure that other operations are not inadvertently affected, at least 10% of initiating devices that are not directly affected by the change, up to a maximum of 50 devices, must also be tested and proper system operation verified.

**This system** meets NFPA requirements for operation at 0-49° C/32-120° F and at a relative humidity 93% ± 2% RH (non-condensing) at 32°C ± 2°C (90°F ± 3°F). However, the useful life of the system's standby batteries and the electronic components may be adversely affected by extreme temperature ranges and humidity. Therefore, it is recommended that this system and its peripherals be installed in an environment with a normal room temperature of 15-27° C/60-80° F.

**Verify that wire sizes are adequate** for all initiating and indicating device loops. Most devices cannot tolerate more than a 10% I.R. drop from the specified device voltage.

**Like all solid state electronic devices**, this system may operate erratically or can be damaged when subjected to lightning induced transients. Although no system is completely immune from lightning transients and interference, proper grounding will reduce susceptibility. Overhead or outside aerial wiring is not recommended, due to an increased susceptibility to nearby lightning strikes. Consult with the Technical Services Department if any problems are anticipated or encountered.

**Disconnect AC power and batteries** prior to removing or inserting circuit boards. Failure to do so can damage circuits.

**Remove all electronic assemblies** prior to any drilling, filing, reaming, or punching of the enclosure. When possible, make all cable entries from the sides or rear. Before making modifications, verify that they will not interfere with battery, transformer, or printed circuit board location.

**Do not tighten screw terminals** more than 9 in-lbs. Over-tightening may damage threads, resulting in reduced terminal contact pressure and difficulty with screw terminal removal.

**This system contains static-sensitive components.** Always ground yourself with a proper wrist strap before handling any circuits so that static charges are removed from the body. Use static suppressive packaging to protect electronic assemblies removed from the unit.

**Units with a touchscreen display** should be cleaned with a dry, clean, lint free/microfiber cloth. If additional cleaning is required, apply a small amount of Isopropyl alcohol to the cloth and wipe clean. Do not use detergents, solvents, or water for cleaning. Do not spray liquid directly onto the display.

**Follow the instructions** in the installation, operating, and programming manuals. These instructions must be followed to avoid damage to the control panel and associated equipment. FACP operation and reliability depend upon proper installation.

Precau-D2-11-2017

## FCC Warning

**WARNING:** This equipment generates, uses, and can radiate radio frequency energy and if not installed and used in accordance with the instruction manual may cause interference to radio communications. It has been tested and found to comply with the limits for Class A computing devices pursuant to Subpart B of Part 15 of FCC Rules, which is designed to provide reasonable protection against such interference when devices are operated in a commercial environment. Operation of this equipment in a residential area is likely to cause interference, in which case the user will be required to correct the interference at his or her own expense.

Acclimate®, eVance®, FocalPoint®, Gamewell-FCI®, FFAST Fire Alarm Aspiration Sensing Technology®, Honeywell®, Intelligent FFAST®, SmartScan®, SWIFT®, Velociti®, and E3 Series are registered trademarks of Honeywell International Inc. Microsoft® and Windows® are registered trademarks of the Microsoft Corporation. Chrome™ and Google™ are trademarks of Google Inc. Firefox® is a registered trademark of The Mozilla Foundation.

©2026 by Honeywell International Inc. All rights reserved. Unauthorized use of this document is strictly prohibited.

## Software Downloads

In order to supply the latest features and functionality in fire alarm and life safety technology to our customers, we make frequent upgrades to the embedded software in our products. To ensure that you are installing and programming the latest features, we strongly recommend that you download the most current version of software for each product prior to commissioning any system. Contact Technical Support with any questions about software and the appropriate version for a specific application.

## Documentation Feedback

Your feedback helps us keep our documentation up-to-date and accurate. If you have any comments or suggestions about our online Help or printed manuals, you can email us.

Please include the following information:

- Product name and version number (if applicable)
- Printed manual or online Help
- Topic Title (for online Help)
- Page number (for printed manual)
- Brief description of content you think should be improved or corrected
- Your suggestion for how to correct/improve documentation

Send email messages to:

**FireSystems.TechPubs@honeywell.com**

Please note this email address is for documentation feedback only. If you have any technical issues, please contact Technical Services.



This symbol (shown left) on the product(s) and / or accompanying documents means that used electrical and electronic products should not be mixed with general household waste. For proper treatment, recovery and recycling, contact your local authorities or dealer and ask for the correct method of disposal.

Electrical and electronic equipment contains materials, parts and substances, which can be dangerous to the environment and harmful to human health if the waste of electrical and electronic equipment (WEEE) is not disposed of correctly.

# Table of Contents

<b>Section 1: Product Overview</b>	<b>7</b>
1.1: General	7
1.2: Limits	7
1.3: Wire Runs	7
1.4: AIO Wiring Specifications	7
1.5: Annunciator Power Requirements & Electrical Ratings	8
<b>Section 2: Installation and Configuration</b>	<b>9</b>
2.1: Installation Checklist	9
2.2: Connectors and Switches	9
2.3: Shielding the AIO Circuit	9
2.4: Power and AIO Circuit Connections	10
2.5: End-of-Line Resistors	11
2.6: Setting Addresses and Switches	11
2.6.1: Addressing the GFP-RLD	11
2.6.2: Piezo	11
<b>Section 3: Programming and Operations</b>	<b>13</b>
3.1: Capabilities	13
3.2: Programming the FACP for Remote Annunciation	13
3.2.1: AIO Board Settings	14
3.2.2: General Settings for GFP-RLD	14
3.2.3: Alert Bar Settings for GFP-RLD	16
3.2.4: Node Map Settings for GFP-RLD	16
3.2.5: Custom Action Settings for GFP-RLD	17
3.2.6: Zone Map Settings for GFP-RLD	18
3.3: Event Priority	18
3.4: LED and Keypad Functions	19
3.4.1: System Startup	19
3.4.2: Normal Operations	20
3.4.3: Accessing System Settings	20
Custom Action Screen	20
3.4.4: Configuration Menu	21
3.4.5: Button Commands Screen	21
3.5: Event Screens	22
3.5.1: Local Trouble	25
3.5.2: Releasing Feature Screens	26
3.6: Piezo Enable	29
3.7: Testing the Annunciators	29

It is imperative that the installer understand the requirements of the Authority Having Jurisdiction (AHJ) and be familiar with the standards set forth by the following regulatory agencies:

- Underwriters Laboratories
- National Fire Protection Association

**Before proceeding, the installer should be familiar with the following documents.**



**NFPA Standards**

NFPA 72 National Fire Alarm Code

NFPA 70 National Electrical Code



**Underwriters Laboratories Documents:**

UL 864 Standard for Control Units for Fire Protective Signaling Systems

UL 2017 for General-Purpose Signaling Devices and Systems

**Other**

EIA-232E Serial Interface Standard

EIA-485 Serial Interface Standard

NEC Article 250 Grounding

NEC Article 300 Wiring Methods

NEC Article 760 Fire Protective Signaling Systems

Applicable Local and State Building Codes

Requirements of the Authority Having Jurisdiction (AHJ)

**Related Documents**

Document Name	Document Number
Gamewell FCI GFP Series ULLD	LS10239-053GF-E
GFP-RLD-E3-ADP Installation Manual	LS10426-000GF-E
SLM-318 Module Installation Manual	LS10243-000GE-E

This product has been certified to comply with the requirements in the Standard for Control Units and Accessories for Fire Alarm Systems, UL 864, 10th Edition. Operation of this product with products not tested for UL 864, 10th Edition has not been evaluated. Such operation requires the approval of the Authority Having Jurisdiction (AHJ).

For product compliance, refer to the UL listing cards located on the UL online certification directory at

<https://iq.ulprospector.com/en/>.

# Section 1: Product Overview

## 1.1 General

The GFP-RLD Remote LCD Display annunciator provides the GFP-Series FACP (fire alarm control panel) with remote, serially-connected remote display. A 5" touch screen display will provide an alert bar providing indication and counters for the number of events in the system, an event display area will provide a scrollable display that shows between four and eight events simultaneously, and scrollable up to 50 of the highest priority events in the system. The GFP-RLD provides a key switch for user authentication that will then enable the control inputs for acknowledge, silence, reset, and a configurable activation. Custom action buttons are available via the menu for quick access to enabling/disabling as well as force on/off the state of addressable points. The header bar will flash for unacknowledged events.

Communication between the FACP and the GFP-RLD occurs over a power-limited (Class 2), two-wire serial interface called AIO Annunciator Input/Output). Power for the GFP-RLD is provided via a separate power-limited (Class 2) power loop from the control panel which is inherently supervised by the GFP-RLD (loss of power results in an AIO communication failure at the control panel). These annunciators can also be powered from a power-limited and regulated remote power supply listed for fire-protective signaling use.

The FACP supports a maximum of 10 RLDs (remote displays) configured as a router. Each RLD takes up one of the 10 available router addresses on the AIO bus. The GFP-RLD does not support peripheral annunciators.

**Power Requirements: 18-30VDC, 225 mA max current.**

## 1.2 Limits

An end-of-line resistor must be installed or enabled on the last AIO device. The number of annunciators that can engage in two-way communication depends on the number of addresses available with the given fire alarm control panel. The actual number of AIO devices that can be powered in a particular system depends on the current available from the control panel's power supply. Refer to the FACP's installation manual for more details.

## 1.3 Wire Runs

Communication between the control panel and annunciators occurs over a power-limited (Class 2) 2-wire AIO serial interface. This communication is supervised by the fire alarm control panel. Each annunciator also requires a power-limited 24 VDC power connection. This power circuit is inherently supervised. Loss of power registers as a communication failure at the control panel. The GFP-RLD can also be powered from a power-limited and regulated remote power supply listed for fire-protective signaling use.

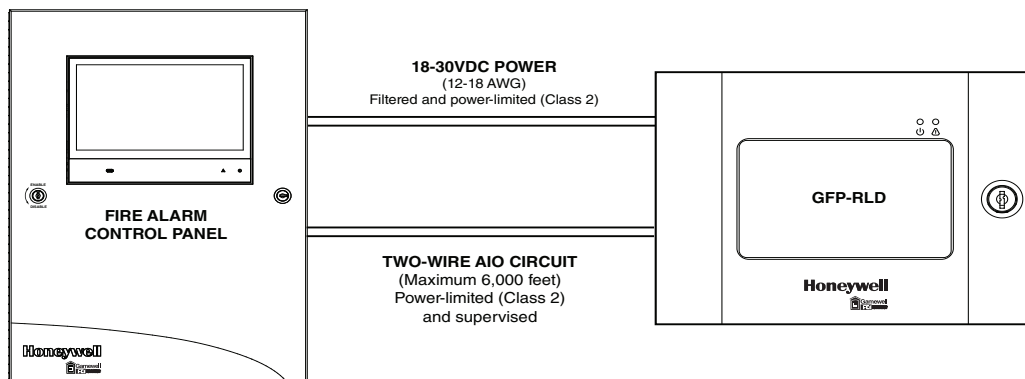

## 1.4 AIO Wiring Specifications

Wire the AIO circuit as shown in Section 2.4, "Power and AIO Circuit Connections". All power must be turned off when connecting the annunciator. These requirements must be followed:

- AIO wiring to the internal or external bus of a control panel can be wired Class A, Class B, DCLA, or DCLB.
- The AIO circuit cannot be T-Tapped; it must be wired in a continuous fashion to function properly.
- The wiring size must be a 12 AWG to 18 AWG twisted pair cable.
- Each AIO circuit must have 18VDC with a max current of 200mA at each device.
- Do not run cable adjacent to, or in the same conduit as, 120 volts AC service, "noisy" electrical circuits that are powering mechanical bells or horns, audio circuits above 25 V<sub>RMS</sub>, motor control circuits, or SCR power circuits.
- If annunciators are to be mounted in a separate cabinet or powered by a remote power supply, see Figure 2.4, "Using Multiple Power Supplies with the AIO Circuit".

## 1.5 Annunciator Power Requirements & Electrical Ratings

Annunciators draw their power from the control panel and must be considered when calculating the primary and secondary power supply requirements for the system. Each annunciator module is accounted for in the power calculations outlined in the respective installation manual. However, if the current draw dedicated to the annunciators must be calculated as a separate figure, use the equations in Table 1.1.

### Electrical Ratings

- Input Voltage: 18-30 VDC (must be power-limited (Class 2) and non-resettable).  
Use a regulated, power-limited (Class 2), compatible power supply that is UL-Listed for Fire Protective Signaling use.
- Data Communications Port: AIO operating for the local AIO at 115.2 Kbps (must be power-limited (Class 2)) and for the main AIO at 57.6Kbps (must be power limited (Class 2)).

Condition	Backlight set in range of 1% – 50%	Backlight set in range of 51% – 100%
Alarm Current (Piezo active)	160mA	225mA
Standby Current (AC Fail Operation = Normal)	150mA	200mA
Standby Current (AC Fail Operation = power save)	75mA	75mA

**Table 1.1 Current Draw Calculations**

## Section 2: Installation and Configuration

### 2.1 Installation Checklist

1. Connect shield for AIO circuit (Section 2.3).
2. Make all electrical connections:
3. Power circuit (Section 2.4)
4. AIO circuit & End-of-line resistor (Sections 2.4 and 2.5).
5. Set module addresses and termination via the on-screen menu (Section 2.6).
6. Program the GFP-RLD annunciators. (Section 3).
7. Test annunciators (Section ).

### 2.2 Connectors and Switches

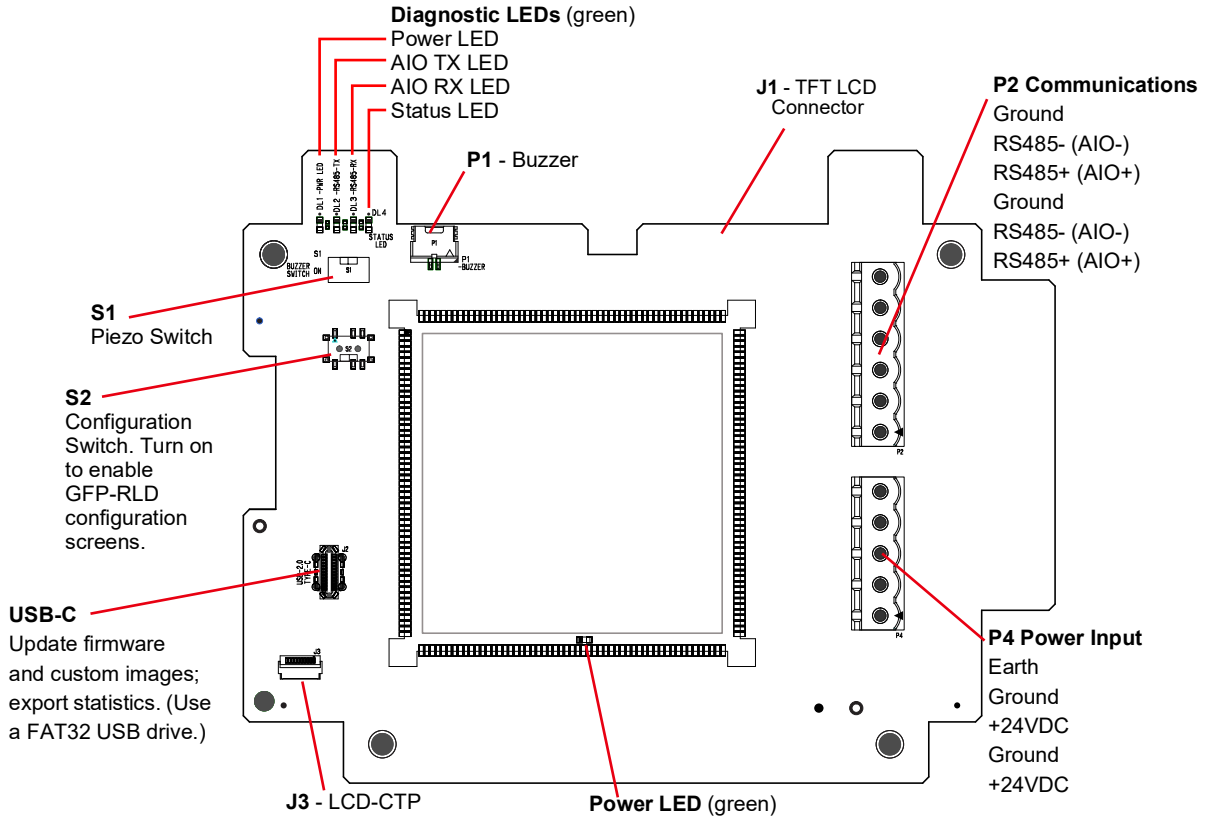

Figure 2.1 GFP-RLD Onboard Features

### 2.3 Shielding the AIO Circuit

The AIO circuit must be wired using a twisted pair cable having a characteristic impedance of 120 ohms, +/- 20%. Do not run cable adjacent to, or in the same conduit as, 120-volt AC service, noisy electrical circuits that are powering mechanical bells or horns, audio circuits above 25 V<sub>RMS</sub>, motor control circuits, or SCR power circuits.

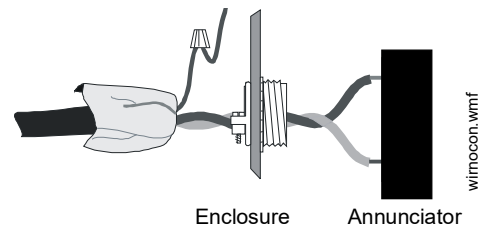

Figure 2.2 Terminating the Shield



**NOTE:** Shielded wire is not necessary but when it is used, the shield should be connected to system ground (not earth) at the FACP and ground on the AIO connector (P2) at the GFP-RLD. If the GFP-RLD is using a remote power supply, the shield will serve as the AIO reference wire.

### 2.4 Power and AIO Circuit Connections

Select an appropriate knockout on the enclosure for the wiring to run through and snap it out. Pull all annunciator wiring into the enclosure. Connect annunciator wiring to the removable terminal blocks at this time. See Section 1.4 on page 7 for circuit requirements.

The GFP-RLD power source must be filtered, non-resettable, 24 VDC listed for fire-protective signaling use. Sources include FACP power supplies and auxiliary power supplies. The power run to the annunciator need not contain a power supervision relay because loss of power is inherently supervised through communication loss (AIO communication loss is registered at the control panel during loss of power to the annunciator).

Connector P2 is the Main AIO bus connection to wire the router to the FACP.

A common reference connection must be made between multiple power supplies for the AIO circuit to function properly.

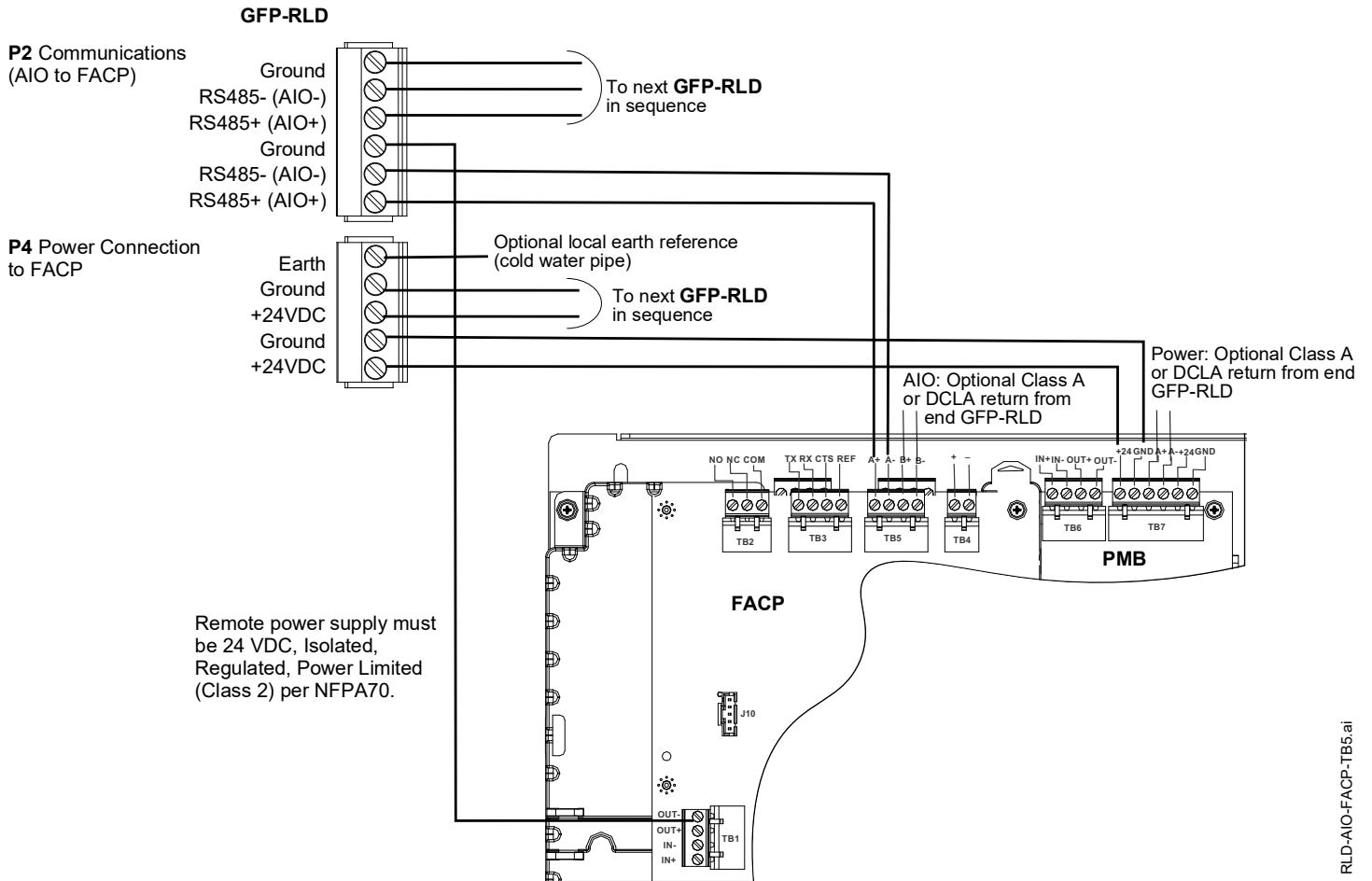

Figure 2.3 AIO and Power Wiring

RLD-AIO-FACP-TB5.ai

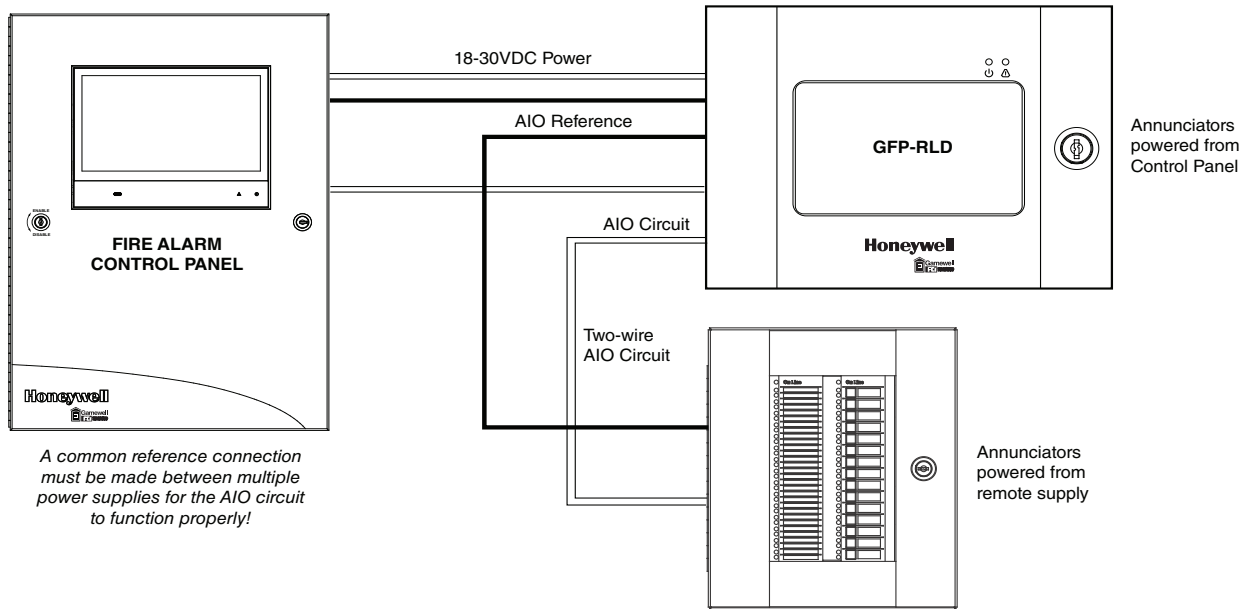

Figure 2.4 Using Multiple Power Supplies with the AIO Circuit

## 2.5 End-of-Line Resistors

The end-of-line termination resistor must be enabled via the on screen menu on the last device on the AIO circuit. All other annunciators should have these switches set to disable.

For termination switch setting, see:

- Initial power-up of a new module - Section 3.4.1, “System Startup”
- Viewing/changing a module already in use - Section 3.4.4, “Configuration Menu”.

## 2.6 Setting Addresses and Switches

### 2.6.1 Addressing the GFP-RLD

Set the address with the on screen menu. This address must match what is entered into CAMWORKS+ programming.

The system supports up to 10 router devices connected to the control panel using up to 10 unique addresses.

Refer to your control panel documentation for valid addresses.

### 2.6.2 Piezo

A piezo will sound if the GFP-RLD is in an off-normal condition.

Slide S1 left to enable the system alarm piezo, or right to disable the piezo.

In CAMWORKS+, under General Settings, each GFP-RLD has a setting for “Piezo Sound For Touch Screen Contact.” This will chirp the piezo for each touch when the key switch is unlocked.

When that setting is checked, the Piezo must be enabled. If the Piezo is disabled when the operation is enabled in CAMWORKS+, the panel will generate a trouble: `AI0 ADDR Nxxx BUZZER SUPERVISORY` trouble (where Nxxx is the GFP-RLD address).

In CAMWORKS+, under General Settings, each GFP-RLD has a setting for “Local Piezo Settings.” This will sound the piezo for each unacknowledged event.

When that setting is checked, the Piezo must be enabled. If the Piezo is disabled when the operation is enabled in CAMWORKS+, the panel will generate a trouble: `AI0 ADDR Nxxx BUZZER SUPERVISORY` (where Nxxx is the GFP-RLD address).



# Section 3: Programming and Operations

## 3.1 Capabilities

GFP-RLD has a high definition touchscreen to display events. The display features a touchpoint for menu access, a header bar which shows event status, and touchpoints for Alarm, for three configurable mapped event types, and for all other event types not already assigned a space on the alert bar. Releasing zones are supported. For general Event Screen layout see Figure 3.1. For specific screens see Section 3.5, "Event Screens" (pages 22– 28).

The GFP-RLD will display all events related to the mapped zone(s) up to 50 total events.

- When more than 50 events related to the mapped zone(s) are active:
  - The system will display the correct event counters (which will add up to a number greater than 50).
  - The system will display a minimum of one event for each active event type.
  - The system will display the remaining active events by priority.  
Priority ordered by:
    1. Event Type (determined by the fire panel)
    2. Event order
      - a. unacknowledged events (earliest in time to latest)
      - b. acknowledged events (earliest to latest)
  - The system will display the alarm status for at least 8 zones simultaneously with fixed indicators for zone status.
  - If the Releasing capability is also used, the GFP-RLD will only display a maximum of 6 events in the list.
- Configurable Control buttons only operational when key switch is unlocked:
  - Acknowledge
  - Silence (also functions as signal silence indicator)
  - Reset
  - Activation (Drill or Alarm Signal On)
- Six programmable buttons, each with:
  - Descriptor/label
  - Status indicator
  - Configurable action (force on/off, disable/enable)
- Technician/Configuration View accessible when config switch is enabled:
  - Provides an interface to make the following settings, changes or viewing the following information (see Section 3.4).
    - Address setting (1 to 10)
    - Backlight intensity (1 to 100)
    - Piezo settings (enabled or disabled)
    - Version Information
    - Statistical Info
    - Firmware Update from USB drive
    - Termination Resistor
    - Upload Custom Image (format type JPG, JPEG, or PNG; resolution 800x480) from FAT32 USB drive
    - Test/Diagnostics

Date	Time	Locked/Unlocked	
Menu/ login	Header Bar	Touchpoint controls (Ack, Silence, Reset, Exit)	
Alert bar	Critical Information Area On GFP-RLD releasing screens, this area displays critical information such as the countdown timer.		
	Events List New events are added at end of the list, and newly acknowledged events are moved to the end of the list. Device events such as an alarmed smoke detector will display data as broken down at right. The exact information provided can vary by event type. For example a System Trouble does not have a type code to display.	Navigation controls (Page forward, Page back)	Events List Information (Device Event Shown) <ol style="list-style-type: none"> <li>1. Event Type</li> <li>2. Type code   Device label*</li> <li>3. Node label and primary zone number   Zone label* At right: Flag for acknowledged events</li> <li>4. Point address At right Date/time stamp of event or acknowledgment</li> </ol> <p>*Custom label entered in programming tool.</p>

Figure 3.1 Event Screen Display

### 3.2 Programming the FACP for Remote Annunciation

Program annunciator points using CAMWORKS+ to enable the GFP-RLD. Refer to Section 2.6 for setting router addresses.

#### 3.2.1 AIO Board Settings

GFP-RLD can only be set as a router. Once the GFP-RLD is selected as a router, no peripherals can be connected to that router.

On CAMWORKS+ AIO Mapping, configure the following router options:

- External Port Style - Class A, Class B, DCLA, or DCLB

The screenshot shows the 'AIO Mappings' window in CAMWORKS+. The 'External Port Style' is set to 'Class B'. A table lists routers R1 through R10 and peripherals P1 through P15. Router R1 is selected with 'RLD' in the dropdown, and all other cells in the table are 'None'.

Router		P1	P2	P3	P4	P5	P6	P7	P8	P9	P10	P11	P12	P13	P14	P15
R1	RLD	None	None	None	None	None	None	None	None	None	None	None	None	None	None	None
R2	None	None	None	None	None	None	None	None	None	None	None	None	None	None	None	None
R3	None	None	None	None	None	None	None	None	None	None	None	None	None	None	None	None
R4	None	None	None	None	None	None	None	None	None	None	None	None	None	None	None	None
R5	None	None	None	None	None	None	None	None	None	None	None	None	None	None	None	None
R6	None	None	None	None	None	None	None	None	None	None	None	None	None	None	None	None
R7	None	None	None	None	None	None	None	None	None	None	None	None	None	None	None	None
R8	None	None	None	None	None	None	None	None	None	None	None	None	None	None	None	None
R9	None	None	None	None	None	None	None	None	None	None	None	None	None	None	None	None
R10	None	None	None	None	None	None	None	None	None	None	None	None	None	None	None	None

#### 3.2.2 General Settings for GFP-RLD

On the CAMWORKS+ General Settings for GFP-RLD, configure options as described below.

The screenshot shows the 'General Settings - R1' window. The 'External Port Style' is 'Class B'. A table lists various settings and their values.

Name	Value
Primary Label	
Language	English
Ac Fail Operation	Power Save
Time Format	HH:MM AMPM
Date Format	US (MM/DD/YY)
Reset Button	Enabled
Silence Button	Enabled
Activation Button	Drill
Piezo Sound For Touch Screen Contact	<input checked="" type="checkbox"/>
Power Supply Node Address	0
PMB Power Supply Enabled	<input type="checkbox"/>
PMB Address	0
Releasing Zone Mapping	

**Primary Label** - 40 character text entry that is used as a label for the annunciator address.

**Language** - Set to English for GFP-RLD v.1.0.

**AC Fail Operation** - Set to Power Save or Normal operation.

- **Power Save** -
  - GFP-RLD will turn off backlight after 5 minutes of inactivity (i.e. no new event received, no touch event, no Key switch event).
  - Backlight will be turned on if any of the above activities occur.
- **Normal** -
  - No change in operation during AC failure.

**Time Format** - Adjusts how the time is displayed on the GFP-RLD.

**Date Format** - Adjusts how the date is displayed on the GFP-RLD.

**Reset Button -**

- **Enabled** - Sends reset command to the panel for the highest priority event when pressed and the keyswitch is in the unlocked position.
- **Disabled** - Reset button is not displayed to the operator.

**Silence Button -**

- **Enabled** - Sends signal silence command to the panel when pressed and the keyswitch is in the unlocked position. The button is also used to indicate the signal silence status.
- **Disabled** - Silence button is not displayed to the operator. The status of signal silence is not viewable on the display.

**Activation Button -**

- **None** - Activation button is not displayed to the operator.
- **Drill** - Sends drill command to the panel when pressed and the keyswitch is in the unlocked position. Additional popup menu is displayed to confirm the selection before sending the event to the panel.
- **Alarm Signal ON** - Sends signal to the panel to turn ON the virtual point in the FACP of a matching address of the RLD, i.e., Alarm Signal ON activation on RLD address 5 will activate FACP virtual point 5. The installer must configure the associated virtual point for the desired operation. For Alarm Signal ON:
  - the virtual point shall be given the label associated with the location of the RLD, the activation event of a Fire Alarm;
  - shall be configured as silenceable to ensure it can be reused to re-initiate the alarm signal after a silence condition;
  - the Forward Zone shall be use to activate outputs associated with the alarm signal;
  - the virtual point shall be reportable and configured to be recorded in history.
  - The Type Code Label is a custom text field that can be used to indicate "Alarm Signal".

**Note:** The GFP-RLD display can be configured to support Drill or Alarm Signal ON. Drill and Alarm Signal ON are mutually exclusive on the GFP-RLD due to the limited space on the display.

**Piezo Sound For Touch Screen Contact** - Audible chirp when touching the display and the key switch is in the unlocked position.

**Local Piezo Setting** - Audible patterns for unacknowledged event conditions.

- Fire alarm - Steady
- MNS alarm - Steady (future use)
- CO alarm - 2Hz
- Supervisory - 1Hz
- Security - 8Hz
- Trouble - 1Hz
- Disable - 1Hz
- Pre-alarm - 2Hz

**Ack Button -**

- **Enabled** - Sends acknowledge (ACK) command to the panel for the highest priority unacknowledged event when pressed and the keyswitch is in the unlocked position.
- **Disabled** - Acknowledge button is not displayed to the operator.

**Power Supply Node Address** - Enter the node number of the panel that is monitoring the power supply providing power to the GFP-RLD. An AC Fail event from this node will indicate that the GFP-RLD is operating on secondary power, and enter power save mode if enabled.

**PMB Power Supply Enabled** - Select this box if the power supply node address is the FACP with an addressable power main board (PMB).

**PMB Address** - Provide the specific address of the PMB that is providing power to the GFP-RLD for appropriate operation for power save and power indication.

**Releasing Zone Mapping** - Enter the releasing zone address to be mapped for display in the critical-information area above the events list.

### 3.2.3 Alert Bar Settings for GFP-RLD

Select the 5 event categories to be displayed on the alert bar of this GFP-RLD. First position must be Fire Alarm. Last position must be Other. Events in categories not selected will be displayed and counted in the “other” category.

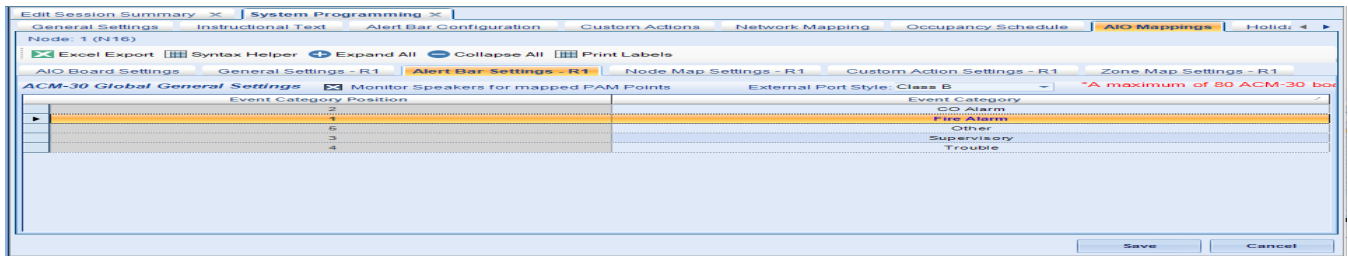

### 3.2.4 Node Map Settings for GFP-RLD

The GFP-RLD may be configured to match the FACP node map or to operate with a subset of the FACP node map for event filtering based on node address. A node cannot be selected that is not selected in the FACP panel node map. GFP-RLD will not show events from nodes not selected.

**NOTE:** Node 0 must be mapped to the local node, regardless of the network’s number for that node.

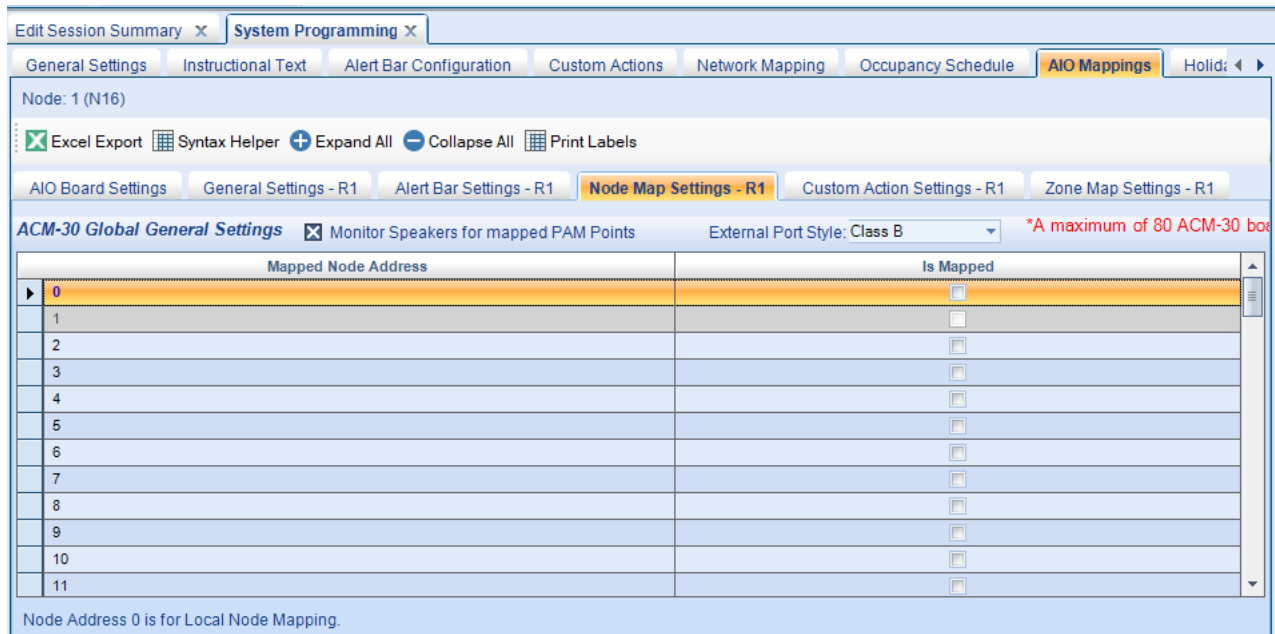

RLDVFT-4NodeMap.png

### 3.2.5 Custom Action Settings for GFP-RLD

Program 6 custom action buttons that will be accessible to operator without panel login.



**NOTE:** If a Custom Action Button programmed to manually control a life safety function, there must be a visual indicator programmed on an ACM-30 at the main operator to interface, to show the function's status. Life safety functions include Elevator Recall, HVAC Shutdown, etc.

Each button is selectable for the operations of enable/disable and Turn on/Turn off.

The label will be displayed on the GFP-RLD next to the buttons.

A maximum of 24 addressable points may be assigned to the 6 custom buttons.

All 24 addressable points can be assigned to a single button.

4 addressable points can be assigned to each of the 6 buttons.

Custom Action	Enable/Disable	TurnOn/TurnOff	Label
1	<input checked="" type="checkbox"/>	<input checked="" type="checkbox"/>	
2	<input checked="" type="checkbox"/>	<input checked="" type="checkbox"/>	
3	<input checked="" type="checkbox"/>	<input checked="" type="checkbox"/>	
4	<input checked="" type="checkbox"/>	<input checked="" type="checkbox"/>	
5	<input checked="" type="checkbox"/>	<input checked="" type="checkbox"/>	
6	<input checked="" type="checkbox"/>	<input checked="" type="checkbox"/>	

Total Points Configured for Custom Action 1 : 0  
Total Points Configured : 0 of 24

RLDVFT-CustomAction.png

### 3.2.6 Zone Map Settings for GFP-RLD

The GFP-RLD may be configured to match the FACP zone map or to operate with a subset of the FACP zone map for event filtering based on primary zone assignment.

Zone events can be filtered on one node at a time. If more than one node is mapped, the Zone Map Settings tab is not available. General system events will be displayed only if Zone 0 is mapped.

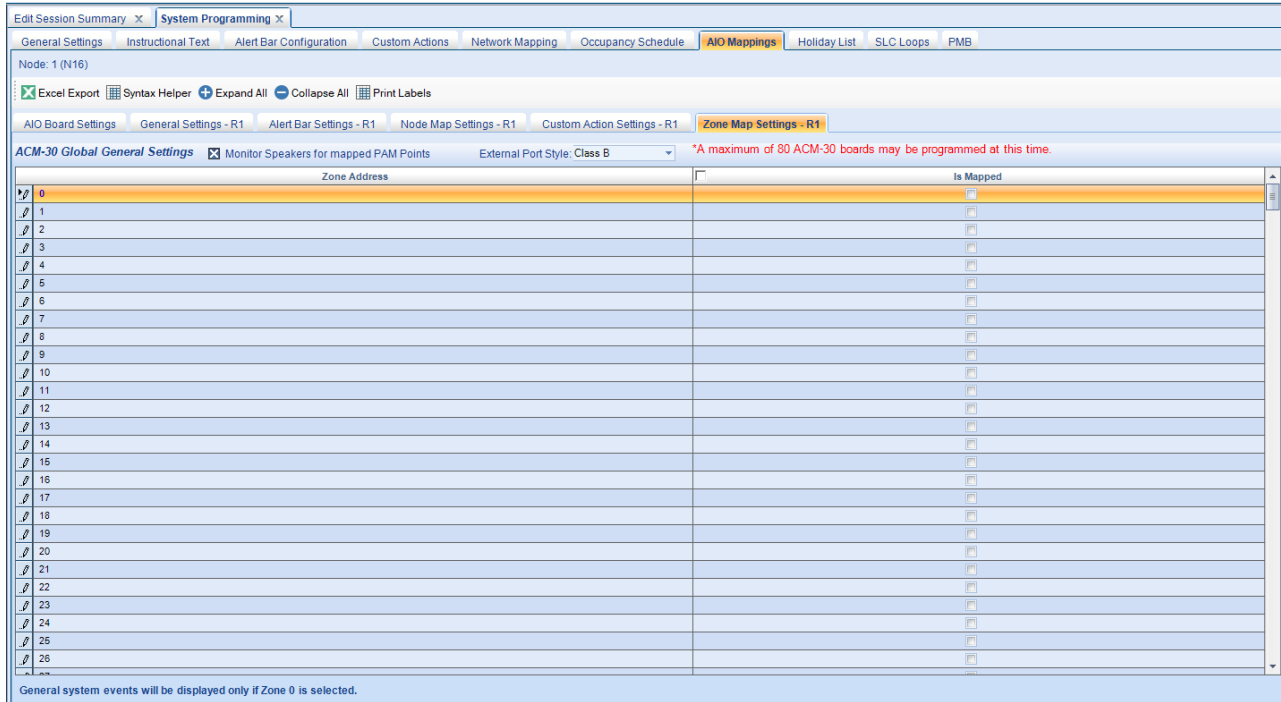

RLDVFT-ZoneMap2024.png

### 3.3 Event Priority

The Event Priority option allows the programmer to configure the control panel features listed next using CAMWORKS+. To configure the Event Priority with the FACP, select the **General Settings>Display Settings>Event Ordering**. From the Event Ordering drop-down menu the programmer selects USA.

The following event priority list is available in the USA:

- FIRE
- CO
- Supervisory
- Troubles
- Disables

### 3.4 LED and Keypad Functions

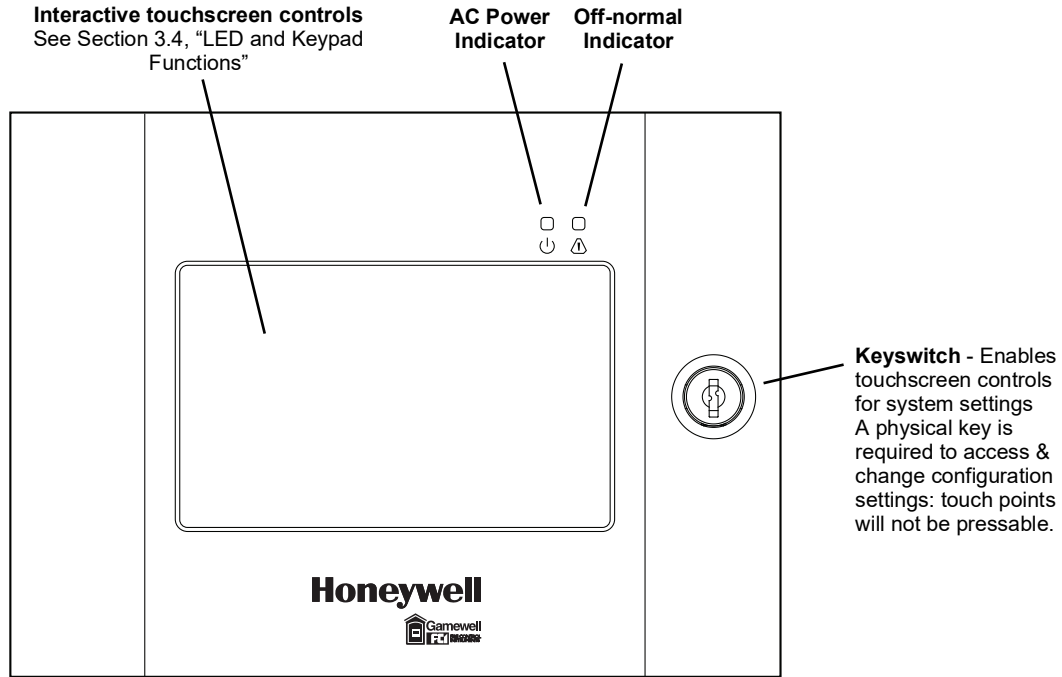

Figure 3.2 External View

#### 3.4.1 System Startup

On initial startup, GFP-RLD will display annunciator version and model number. Enter the address and termination status for the unit.

1. **Address.** Press the touch point for ADDRESS 1 to ADDRESS 10. The unit will save the information and move to the next screen. Each GFP-RLD requires a unique address, and the addressing order is independent of the order in which the units are wired on the bus.
2. **Termination Status.**
  - If this GFP-RLD is the final one in the bus, press TERMINATE.
  - Press DONE to initialize the unit.

Key Switch : Unlocked

Application Version: 1.0.225 Date: 05/10/2021 Time: 08:27 AM

Model Number: GFP-RLD

---

Select Address

ADDRESS 1	ADDRESS 2	ADDRESS 3	ADDRESS 4
ADDRESS 5	ADDRESS 6	ADDRESS 7	ADDRESS 8
ADDRESS 9	ADDRESS 10		

Key Switch : Unlocked

Application Version: 1.0.225 Date: 05/10/2021 Time: 08:27 AM

Model Number: GFP-RLD

---

Set Termination Status

Address 1	No Termination	<div style="border: 1px solid black; padding: 2px 10px;">TERMINATE</div>
-----------	----------------	--

---

	<div style="border: 1px solid black; padding: 2px 10px;">BACK</div>	<div style="border: 1px solid black; padding: 2px 10px;">DONE</div>
--	---	---

### 3.4.2 Normal Operations

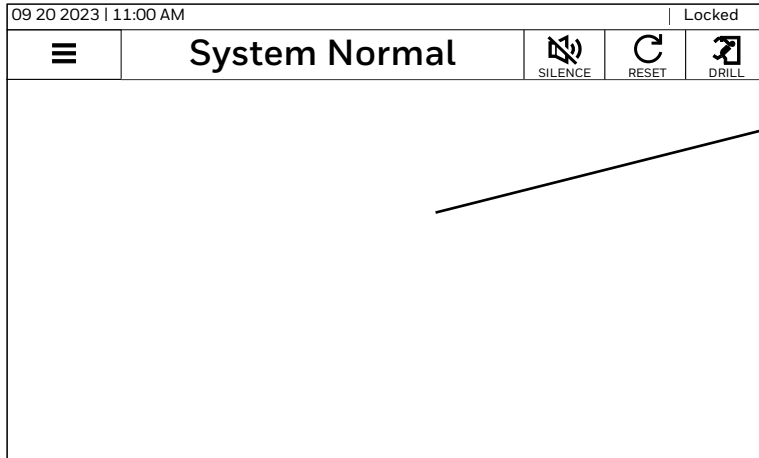

This area can display a custom image. (See Section 3.2.5 for instructions on loading from USB.)

### 3.4.3 Accessing System Settings

Turn on the keyswitch to access Custom Actions and Configuration.

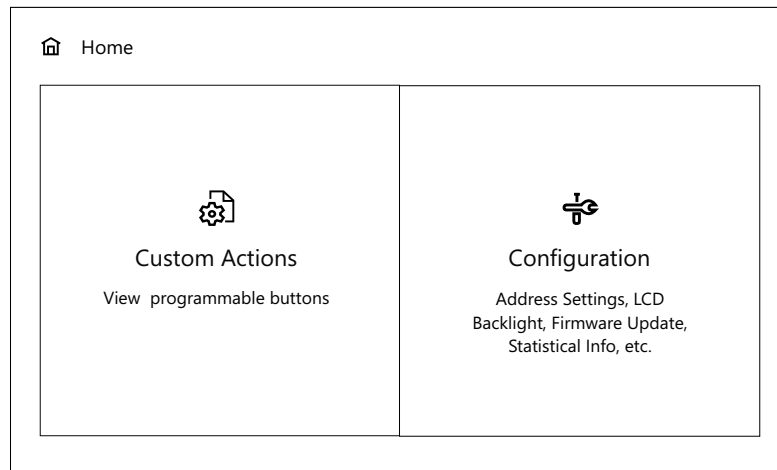

### Custom Action Screen

Displays label assigned in CAMWORKS+ to represent map points. Disable/enable the custom action buttons from one of three screens, accessed by pressing the touch points at the bottom of the screens.

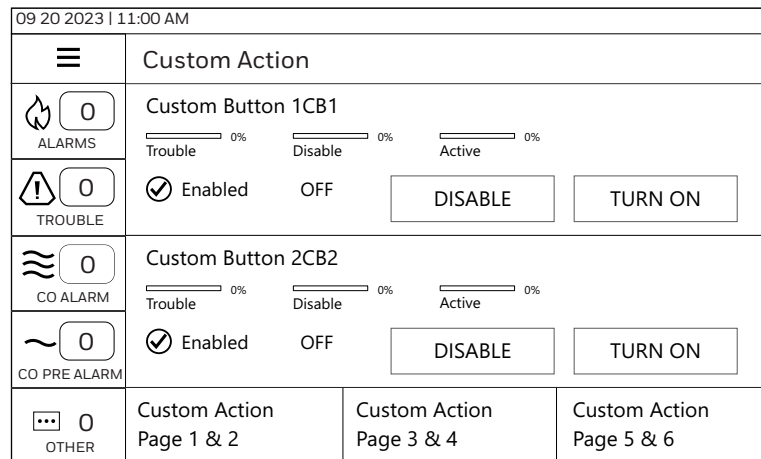

### 3.4.4 Configuration Menu

Access address settings, firmware updates, statistical info, and user options.

07 02 2020   4:07 PM	
☰ Configuration	
Address Settings	Firmware Update
Backlight Intensity	Termination Resistor
Local Event Piezo	Upload Custom Image
Version Information	Test/Diagnostics
Statistical Information	

**Address Settings Screen** - Press a new address to change the setting of this GFP-RLD. Updating address will trigger a restart.

**Backlight Intensity Screen** - Press and hold slider touch point to change screen brightness.

**Local Event Piezo Screen**- Press to enable or disable local sound. See Section 2.6.2, “Piezo” for interaction with CAMWORKS+ programming.

**Version Information Screen**- Display GFP-RLD version information: application, operating system, bootloader, hardware, database, and GFP-RLD serial number. Press and hold the slide touch point at right to move up and down for more information.

**Statistical Information Screen**- Display GFP-RLD history: Last restart, messages sent from API, Messages sent from IB2, Messages received by API, Messages received by IB2, Flow control errors, Read overflow prevention errors, CRC errors, Buffer full errors, Out of sync errors, Schema count. Press and hold the slide touch point at right to move up and down for more information.

**Firmware Update Screen** - Log in at the panel and activate “Service Mode” via panel settings (see panel documentation). Insert USB stick with RLD\_fwupdate.zip located in the USB’s root directory. **Do NOT unzip the firmware pack.** Press UPDATE to continue. Reboot after successful update.

**Termination Resistor** - The termination resistor should be activated only for the final GFP-RLD on the bus.

**Upload Custom Image Screen** - Insert image on FAT32 USB drive and press PREVIEW or UPLOAD. (Image formats: JPG, JPEG, or PNG. Image resolution: 800 x 480 pixels)

**Test/Diagnostics Screen** -

- **Lamp Test** - Screen will light up white for 5 seconds.
- **Export Logs** - Before pressing the touch point, insert a USB drive with at least 15MB free space.
- **Temperature** - Displays circuit board temperature, CPU temperature, and the highest temperature for both since last reset. Press RESET to clear temperature history.

### 3.4.5 Button Commands Screen

**Activation Button** -

- **Drill** - Sends drill command to the panel when pressed and the keyswitch is in the unlocked position. Additional popup menu is displayed to confirm the selection before sending the event to the panel.
- **Alarm Signal ON** - Sends signal to the panel to turn ON the control module. The installer must physically wire or connect a relay module to the input of a monitor module. The monitor module will be configured as a “Track Alarm” monitor module that will create the Fire Alarm Event. The panel should go into a fire alarm condition when the monitor module becomes active.

**Note:** The Activation button can be configured as a Drill, Alarm Signal ON, or None button.

**Silence Button** - Press SILENCE to set the system to SILENCED. The button background will change from gray to black. If NACs re-energize, button background will change back from black to gray, the button will change from SILENCED to SILENCE, and the button will function to silence NACs every time it is pressed.

### 3.5 Event Screens

#### Fire Alarm

09 20 2023   11:00 AM		Unlocked			
☰ ALARMS		ACK	SILENCE	RESET	DRILL
🔥 8 ALARMS	Fire Alarm N52 Z80   primary zone Label	09 20 2023   6:11 PM			⬆️
	Fire Alarm N52 Z80   primary zone Label	09 20 2023   6:11 PM			⬆️
🚫 0 DISABLE	Fire Alarm N52 Z80   primary zone Label	09 20 2023   6:11 PM			⬆️
	Fire Alarm N52 Z80   primary zone Label	09 20 2023   6:11 PM			1 / 5
🌊 0 CO ALARM	Fire Alarm N52 Z80   primary zone Label	09 20 2023   6:11 PM			⬆️
	Fire Alarm N52 Z80   primary zone Label	09 20 2023   6:11 PM			⬆️
👤 1 SUPERVISORY	Fire Alarm N52 Z80   primary zone Label	09 20 2023   6:11 PM			⬆️
	Fire Alarm N52 Z80   primary zone Label	09 20 2023   6:11 PM			⬆️
⋮ 0 OTHER	Fire Alarm N52 Z80   primary zone Label	09 20 2023   6:11 PM			⬆️
	Fire Alarm N52 Z80   primary zone Label	09 20 2023   6:11 PM			⬆️

#### Supervisory Alarm

09 20 2023   11:00 AM		Unlocked			
☰ SUPERVISORY ALARMS		ACK	SILENCE	RESET	DRILL
🔥 0 ALARMS	Supervisory Signal Sup L (Duct I)   Custom label N52 Z80   Primary zone label	09 20 2023   10:59 AM			⬆️
	Supervisory Signal Smoke (Photo)   Custom label N52 Z80   Primary zone label	⓪ Acknowledged 09 20 2023   10:55 AM			1 / 2
🌊 0 CO ALARM	Supervisory Signal Smoke (Photo)   Custom label N52 Z80   Primary zone label	⓪ Acknowledged 09 20 2023   10:55 AM			1 / 2
	Supervisory Signal Smoke (Photo)   Custom label N52 Z80   Primary zone label	⓪ Acknowledged 09 20 2023   10:55 AM			1 / 2
👤 2 SUPERVISORY	Supervisory Signal Smoke (Photo)   Custom label N52 Z80   Primary zone label	⓪ Acknowledged 09 20 2023   10:55 AM			1 / 2
	Supervisory Signal Smoke (Photo)   Custom label N52 Z80   Primary zone label	⓪ Acknowledged 09 20 2023   10:55 AM			1 / 2
⋮ 0 OTHER	Supervisory Signal Smoke (Photo)   Custom label N52 Z80   Primary zone label	⓪ Acknowledged 09 20 2023   10:55 AM			1 / 2
	Supervisory Signal Smoke (Photo)   Custom label N52 Z80   Primary zone label	⓪ Acknowledged 09 20 2023   10:55 AM			1 / 2

#### Ground Fault

03 11 2024   11: 16 AM		GND FLT				Unlocked		
☰ TROUBLE		ACK	SILENCE	RESET	DRILL			
🔥 0 FIRE ALARM	OFF WATER RELEASING ZONE: TWO Water							
	Service Mode Enabled N1							
🌊 0 CO ALARM	N1 T812	03 11 2024   11:13 AM						
	CHANGE SERVICE TOOL PASSWORD N1						1 / 17	
⚠️ 17 TROUBLE	N1 T727	03 11 2024   11:13 AM						
	DATABASE CORRUPTED N1						⬆️	
⋮ 0 OTHER	N1 T812	03 11 2024   11:13 AM						
	N1 T812	03 11 2024   11:13 AM					⬆️	

**Trouble**

09 20 2023   11:00 AM		Unlocked			
☰	TROUBLE	ACK	SILENCE	RESET	DRILL
0 ALARMS	No response Smoke (Photo)   Detector L01D003 N1 Z1   Zone Z0001				↑↑
2 TROUBLE	N1 L1 D3 09 20 2023   10:59 AM				↑
	No response Smoke (Photo)   Detector L01D004 N1 Z1   Zone Z0001			☑ Acknowledged	
0 CO ALARM	N1 L1 D4 09 20 2023   10:59 AM				1 / 2
0 PRE ALARM					↓
0 OTHER					↓↓

**CO Alarm**

09 20 2023   11:00 AM		Unlocked			
☰	CO ALARM	ACK	SILENCE	RESET	DRILL
0 ALARMS	CO Pre-Alarm Air Reference   Detector L01D060 N1 Z1   Zone Z0001			☑ Acknowledged	↑↑
	N1 L1 D60 09 20 2023   10:59 AM				↑
1 CO PRE ALARM	CO Alarm Air Reference   Detector L01D064 N1 Z1   Zone Z0001			☑ Acknowledged	
1 CO ALARM	N1 L1 D64 09 20 2023   10:59 AM				1 / 2
0 OTHER					↓
					↓↓

**Critical Process**

09 20 2023   11:00 AM		Unlocked			
☰	CRITICAL PROCESS	ACK	SILENCE	RESET	DRILL
0 ALARMS	Critical Process (Life) Sup L (Duct I)   Detector L01D043 N1 Z1   Zone Z0001			☑ Acknowledged	↑↑
2 CRIT PROC	N1 L1 D43 09 20 2023   10:59 AM				↑
	Critical Process (Life) Smoke (Photo)   Detector L01D044 N1 Z1   Zone Z0001			☑ Acknowledged	
0 SECURITY	N1 L1 D44 09 20 2023   10:59 AM				1 / 2
0 SUPERVISORY					↓
0 OTHER					↓↓

**Disable Alarm**

09 20 2023   11:00 AM		Unlocked			
	<b>DISABLE</b>				
0 ALARMS	Disable Active Sup L (Duct I)   Custom label N32 L1M1   Primary zone label				↑
2 DISABLE	N1 L1 D53 09 20 2023   10:59 AM Zone Disabled Air Reference   Custom label				↑
0 SECURITY	N52 Z80   Primary zone label <input checked="" type="checkbox"/> Acknowledged N52 L1 M1 09 20 2023   10:59 AM				1 / 2
0 SUPERVISORY					↓
0 OTHER					↓

**CO-Pre Alarm**

09 20 2023   11:00 AM		Unlocked			
	<b>CO PRE ALARM</b>				
0 ALARMS	CO Pre-Alarm Heat (fixed)   Custom label N52 Z80   Primary zone label				↑
2 CO PRE ALARM	N52 L1 M2 09 20 2023   10:59 AM CO Pre-Alarm Air Reference   Custom label				↑
0 CO ALARM	N52 Z80   Primary zone label <input checked="" type="checkbox"/> Acknowledged N52 L1 M1 09 20 2023   10:59 AM				1 / 2
0 TROUBLE					↓
0 OTHER					↓

**Pre Alarm**

09 20 2023   11:00 AM		Unlocked			
	<b>PRE ALARMS</b>				
0 ALARMS	Pre-Alarm Smoke (Duct L)   Custom label N52 Z80   Primary zone label				↑
0 CO PRE ALARM	N52 L1 M1 09 20 2023   10:59 AM Pre-Alarm Unknown Type   Custom label				↑
0 TROUBLE	N52 Z80   Primary zone label N52 L1 M2 09 20 2023   10:59 AM				1 / 2
2 PRE ALARM					↓
0 OTHER					↓

**Other Alarm**

09 20 2023   11:00 AM		Unlocked			
☰ OTHER EVENTS		☑ ACK	🔇 SILENCE	🔄 RESET	🔍 DRILL
🔥 0 ALARMS	DISABLED Heat (Fixed)   Custom label N52 Z80   Primary zone label N52 L1 M1	09 20 2023   10:59 AM			⬆️
🌫️ 0 CO PRE ALARM	TROUBLE   Det Failed Test Heat (Fixed)   Custom label N52 Z80   Primary zone label	🗒️ Acknowledged 09 20 2023   10:59 AM			⬆️
🚪 0 SECURITY		1 / 2			
👮 0 SUPERVISORY					⬇️
⋮ 2 OTHER					⬇️

**3.5.1 Local Trouble**

**Offline Trouble**

09 20 2023   11:00 AM		Unlocked			
☰ TROUBLE		☑ ACK	🔇 SILENCE	🔄 RESET	🔍 DRILL
🔥 - ALARMS	AIO Address 2 Comm Loss				⬆️
⚠️ 1 TROUBLE					⬆️
🌫️ - CO ALARM		1 / 1			
🗨️ - PRE ALARM					⬇️
⋮ - OTHER					⬇️

**Configuration Trouble**

09 20 2023   11:00 AM		Unlocked			
☰ TROUBLE		☑ ACK	🔇 SILENCE	🔄 RESET	🔍 DRILL
🔥 0 ALARMS	Missing Configuration.				⬆️
⚠️ 1 TROUBLE					⬆️
🌫️ 0 CO ALARM		1 / 1			
🗨️ 0 PRE ALARM					⬇️
⋮ 0 OTHER					⬇️

### 3.5.2 Releasing Feature Screens

#### Abort

09 20 2023   11:43 AM		Unlocked	
	ABORT		
	0		
ABORT RELEASING ZONE : ZR15 Releasing zone event label		Discharge Starts in: <b>0:18</b>	
	4	Disabled Pre-Alarm Air Reference   Custom label N52 P1.2   Primary zone label N52 P1.2	
	0	09 20 2023   10:35 AM	
	0	Disabled Pre-Alarm Air Reference   Custom label N52 P1.3   Primary zone label N52 P1.3	
		09 20 2023   10:35 AM	
		1 / 8	
	4	Disabled Pre-Alarm Air Reference   Custom label N52 P1.4   Primary zone label N52 P1.4	
		09 20 2023   10:35 AM	
		↓	
		⌵	

#### First Alarm

09 20 2023   11:39 AM		Unlocked	
	DISABLE		
	0		
FIRST ALARM RELEASING ZONE : ZR15 Releasing zone event label		Pending Additional Activation Condition	
	3	Disabled Pre-Alarm Air Reference   Custom label N52 P1.2   Primary zone label N52 P1.2	
	0	09 20 2023   10:35 AM	
	0	Disabled Pre-Alarm Air Reference   Custom label N52 P1.3   Primary zone label N52 P1.3	
		09 20 2023   10:35 AM	
		7 / 8	
	5	Disabled Pre-Alarm Air Reference   Custom label N52 P1.4   Primary zone label N52 P1.4	
		09 20 2023   10:35 AM	
		↑	
		↓	

#### Cross Abort

09 20 2023   11:43 AM		Unlocked	
	DISABLE		
	0		
CROSS-ABORT RELEASING ZONE : ZR20 Releasing zone event label		Discharge Starts in: <b>0:12</b>	
	4	Disabled Pre-Alarm Air Reference   Custom label N52 P1.2   Primary zone label N52 P1.2	
	0	09 20 2023   10:35 AM	
	0	Disabled Pre-Alarm Air Reference   Custom label N52 P1.3   Primary zone label N52 P1.3	
		09 20 2023   10:35 AM	
		1 / 8	
	0	Disabled Pre-Alarm Air Reference   Custom label N52 P1.4   Primary zone label N52 P1.4	
		09 20 2023   10:35 AM	
		↓	
		⌵	

**Off-State**

09 20 2023   10:59 AM		Unlocked			
	DISABLE				
0 ALARMS	OFF RELEASING ZONE : ZR12 Releasing zone event label				
6 DISABLE	Disabled Pre-Alarm Air Reference   Custom label N52 P1.2   Primary zone label N52 P1.2				09 20 2023   10:35 AM
0 TROUBLE	Disabled Pre-Alarm Air Reference   Custom label N52 P1.3   Primary zone label N52 P1.3				09 20 2023   10:35 AM
0 SUPERVISORY	Disabled Pre-Alarm Air Reference   Custom label N52 P1.4   Primary zone label N52 P1.4				09 20 2023   10:35 AM
2 OTHER					1 / 8
					↓
					⌵

**On/Discharge Stop Timer**

09 20 2023   11:01 AM		Unlocked			
	DISABLE				
0 ALARMS	ON/DISCHARGE RELEASING ZONE : ZR1 Releasing zone event label				
6 DISABLE	Disabled Trouble Event label   Custom label N52 P1.2   Primary zone label N52 P1.2				09 20 2023   10:59 AM
0 TROUBLE	Disabled Trouble Event label   Custom label N52 P1.3   Primary zone label N52 P1.3				09 20 2023   10:59 AM
0 SUPERVISORY	Disabled Trouble Event label   Custom label N52 P1.4   Primary zone label N52 P1.4				09 20 2023   10:59 AM
2 OTHER					1 / 8
					↓
					⌵

**On/Discharge With Timer**

09 20 2023   11:19 AM		Unlocked			
	DISABLE				
1 ALARMS	ON/DISCHARGE RELEASING ZONE : ZR12 Releasing zone event label			Discharge Ends in: <b>0:05</b>	
3 DISABLE	Disabled Pre-Alarm Air Reference   Custom label N52 P1.2   Primary zone label N52 P1.2				09 20 2023   10:35 AM
0 TROUBLE	Disabled Pre-Alarm Air Reference   Custom label N52 P1.3   Primary zone label N52 P1.3				09 20 2023   10:35 AM
0 SUPERVISORY	Disabled Pre-Alarm Air Reference   Custom label N52 P1.4   Primary zone label N52 P1.4				09 20 2023   10:35 AM
0 OTHER					5 / 8
					↑
					↓
					⌵

**Pre-Discharge with Timer**

09 20 2023   11:19		Unlocked			
	DISABLE				
1 ALARMS	PRE-DISCHARGE RELEASING ZONE : ZR12 Releasing zone event label	Discharge Starts in: <b>1:54</b>			
3 DISABLE	Disabled Pre-Alarm Air Reference   Custom label N52 P1.2   Primary zone label N52 P1.2	09 20 2023   6:35		↑	
0 SECURITY	Disabled Pre-Alarm Air Reference   Custom label N52 P1.2   Primary zone label N52 P1.2	09 20 2023   6:35		↑	
0 SUPERVISORY	Disabled Pre-Alarm Air Reference   Custom label N52 P1.2   Primary zone label N52 P1.2	09 20 2023   6:35		4 / 4	
0 OTHER	Disabled Pre-Alarm Air Reference   Custom label N52 P1.2   Primary zone label N52 P1.2	09 20 2023   6:35		↓	

**Soak Expired**

09 20 2023   11:00 AM		Unlocked			
	DISABLE				
0 ALARMS	SOAK EXPIRED RELEASING ZONE : ZR22 Releasing zone event label				
6 DISABLE	Disabled Trouble Event label   Custom label N52 P1.2   Primary zone label N52 P1.2	09 20 2023   10:59 AM			
0 CO ALARM	Disabled Trouble Event label   Custom label N52 P1.3   Primary zone label N52 P1.3	09 20 2023   10:59 AM		1 / 8	
0 SUPERVISORY	Disabled Trouble Event label   Custom label N52 P1.4   Primary zone label N52 P1.4	09 20 2023   10:59 AM		↓	
2 OTHER	Disabled Trouble Event label   Custom label N52 P1.4   Primary zone label N52 P1.4	09 20 2023   10:59 AM		↓	

### 3.6 Piezo Enable

To enable the piezo, configure GFP-RLD for supervision using CAMWORKS+. The switch on the unit is a local disconnect.

Event	Piezo Frequency
Fire Alarm	Steady On
Security	8 Hz
Crit Proc	2 Hz
CO Alarm	2 Hz
CO-Pre Alarm	2 Hz
Supervisory	1 Hz
Trouble	1 Hz
Disable	1 Hz
Pre Alarm	2 Hz
All Other events except above	2 Hz
Non-Fire Activation	
Medical Emergency (Life)	
Maintenance	
Non-Fire Activation No ACK	No Piezo Output

**Table 3.1 Piezo Operation for FACP Functions**



**NOTE:** The audible pattern will only be active for unacknowledged events.

### 3.7 Testing the Annunciators

After programming, fully test the annunciator to ensure that each switch performs its intended function, that each LED lights in the correct color, and that the annunciators can perform the functions outlined in this manual. Perform a lamp test to ensure all LEDs light correctly.

## Notes

## Notes

## **Notes**





## **Manufacturer Warranties and Limitation of Liability**

**Manufacturer Warranties.** Subject to the limitations set forth herein, Manufacturer warrants that the Products manufactured by it in its Northford, Connecticut facility and sold by it to its authorized Distributors shall be free, under normal use and service, from defects in material and workmanship for a period of thirty six months (36) months from the date of manufacture (effective Jan. 1, 2009). The Products manufactured and sold by Manufacturer are date stamped at the time of production. Manufacturer does not warrant Products that are not manufactured by it in its Northford, Connecticut facility but assigns to its Distributor, to the extent possible, any warranty offered by the manufacturer of such product. This warranty shall be void if a Product is altered, serviced or repaired by anyone other than Manufacturer or its authorized Distributors. This warranty shall also be void if there is a failure to maintain the Products and the systems in which they operate in proper working conditions.

MANUFACTURER MAKES NO FURTHER WARRANTIES, AND DISCLAIMS ANY AND ALL OTHER WARRANTIES, EITHER EXPRESSED OR IMPLIED, WITH RESPECT TO THE PRODUCTS, TRADEMARKS, PROGRAMS AND SERVICES RENDERED BY MANUFACTURER INCLUDING WITHOUT LIMITATION, INFRINGEMENT, TITLE, MERCHANTABILITY, OR FITNESS FOR ANY PARTICULAR PURPOSE. MANUFACTURER SHALL NOT BE LIABLE FOR ANY PERSONAL INJURY OR DEATH WHICH MAY ARISE IN THE COURSE OF, OR AS A RESULT OF, PERSONAL, COMMERCIAL OR INDUSTRIAL USES OF ITS PRODUCTS.

This document constitutes the only warranty made by Manufacturer with respect to its products and replaces all previous warranties and is the only warranty made by Manufacturer. No increase or alteration, written or verbal, of the obligation of this warranty is authorized. Manufacturer does not represent that its products will prevent any loss by fire or otherwise.

**Warranty Claims.** Manufacturer shall replace or repair, at Manufacturer's discretion, each part returned by its authorized Distributor and acknowledged by Manufacturer to be defective, provided that such part shall have been returned to Manufacturer with all charges prepaid and the authorized Distributor has completed Manufacturer's Return Material Authorization form. The replacement part shall come from Manufacturer's stock and may be new or refurbished. THE FOREGOING IS DISTRIBUTOR'S SOLE AND EXCLUSIVE REMEDY IN THE EVENT OF A WARRANTY CLAIM.

**Honeywell Gamewell-FCI**

12 Clintonville Road  
Northford, CT 06472-1610  
203.484.7161  
[www.gamewell-fci.com](http://www.gamewell-fci.com)

LS10310-002GF-E | A | 02-26  
©2026 Honeywell International Inc.

**Honeywell**

