

3-phase bidirectional energy meter for current converter metering with S0-output

Bidirectional energy meter with S0-interface. The S0 interface is a hardware interface for the transmission of measured values via pulses.

Specifications:

- ▶ 3-phase energy meter, 3 × 230 / 400 VAC 50 Hz
- ▶ Converter metering to 1500 A in both directions of current
- ▶ Display of the active power, voltage and current per phase
- ▶ Display of the total active power
- ▶ S0-output; independent of the direction of current
- ▶ 7-digit display for energy supply and feeding back
- ▶ Can be sealed and is provided with a sealing cap as an accessory
- ▶ Accuracy class B in accordance with EN50470-3, Accuracy class 1 in accordance with IEC62053-21



Order number

Standard version: AWD3B5W10MC2A00
 MID version: AWD3B5W10MC3A00
 Sealing caps: 4 104 7485 0

Technical data

Accuracy class	B in accordance with EN50470-3, 1 in accordance with IEC62053-21
Operating voltage	3 × 230 / 400VAC, 50 Hz Tolerance -20%/+15%
Power consumption	Active 0.4W per phase
Meter range	000'000.0...9'999'999
Display	Backlit LCD, numbers 6 mm high
Display without mains electricity	Condenser protected LCD maximum 2 times in 10 days
S0-output (interface)	Optocoupler max. 30V / 20 mA and min. 5V, impedance 100 Ω, pulse duration 30 ms
Transmission distance	S0-output max. 1000m (at 30V/20mA)

Assembly

Assembly	On 35 mm top-hat rail in accordance with EN60715TH35
Connections Main current circuit	Conductor cross section 1.5 – 16 mm ² , Pozidrive screwdriver size 1, flat-head screwdriver size 2, torque 1.5 – 2 Nm
Connections Control current circuit	Conductor cross section 2.5 mm ² , Pozidrive screwdriver size 0 or flat-head screwdriver size 2, torque 0.8 Nm
Insulating properties	– 4 kV / 50 Hz test in accordance with VDE0435 for energy meters – 6 kV 1.2 / 50 μs overvoltage in accordance with IEC255-4 – Device protection class II
Ambient temperature	–25 °...+55 °C
Storage temperature	–30 °...+85 °C
Environment	Mechanical M2 Electromagnetic E2
Relative humidity	75 % without condensation
EMC/resistance	– Surge voltage in accordance with IEC61000-4-5 at the main current circuit 4 kV at the S0-interface 1 kV – Burst voltage in accordance with IEC61000-4-4, at the main current circuit 4 kV at the S0-interface 1 kV – ESD in accordance with IEC61000-4-2, contact 8 kV, air 15 kV

Converter measurement

		5...1500 A			
Reference current / maximum current		$I_{ref} = 5 \text{ A}, I_{max} = 6 \text{ A}$			
Start current / minimum current		$I_{st} = 10 \text{ mA}, I_{min} = 0.05 \text{ A}$			
Conversion factor		5:5	50:5	100:5	150:5
		200:5	250:5	300:5	400:5
		500:5	600:5	750:5	1000:5
		1250:5	1500:5		
Pulses per kWh	LED S0-output	10 pulses / kWh 10 pulses / kWh			

Error display

Example: Connection error at L3

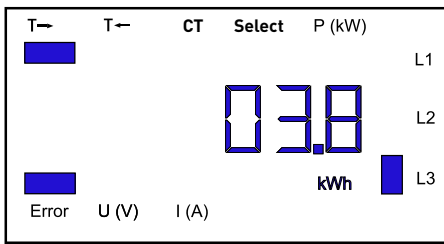

Example: Connection error at L1 and L3

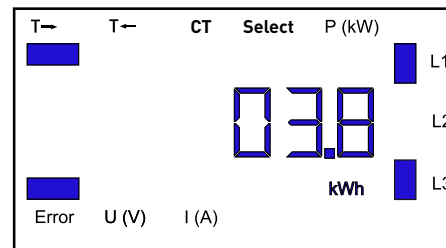

Dimension drawings

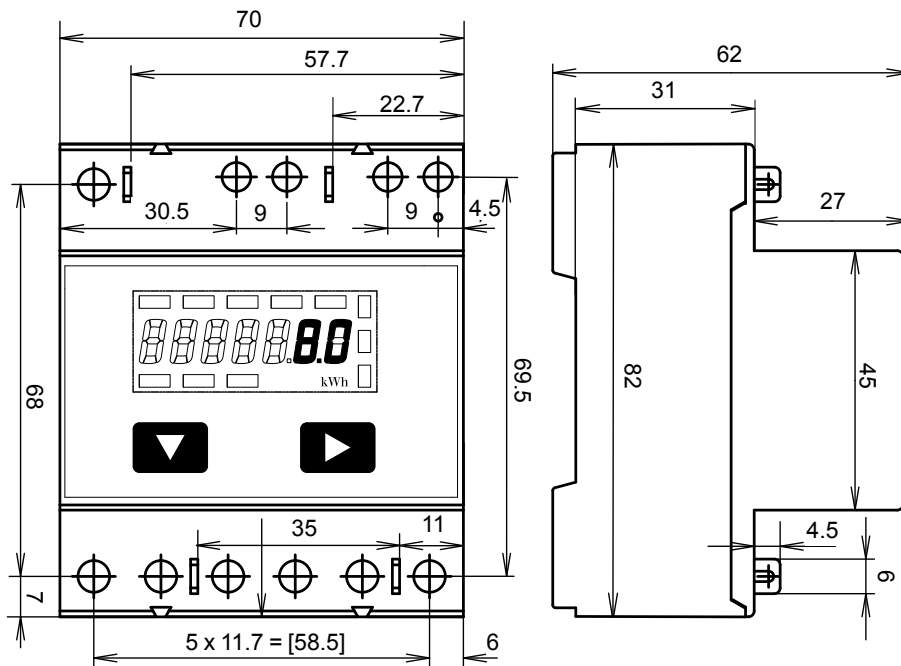

Display components

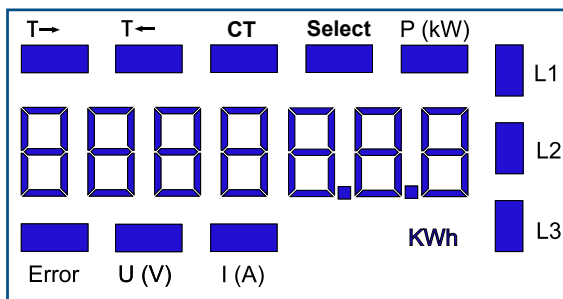

- ▶ T→ Shows the total consumption →
- ▶ T← Shows the total consumption ←
- ▶ CT Shows the set current converter ratio
- ▶ Select When the Z1-Z2 bridge is open, the converter ratio can be set under the menu item: Select
- ▶ P (kW) Shows the present output per phase or for all phases-
Current «→» = supply (P positive)
Current «←» = feeding back (P negative)
- ▶ U (V) Shows the voltage per phase
- ▶ I (A) Shows the current per phase
- ▶ kWh Shows the unit kWh in the consumption display
- ▶ L1/L2/L3 Displays the corresponding phase for the P, U, I or error display
- Error In the absence of a phase. The corresponding phase is also displayed.

Menu used to display the values on the LCD display

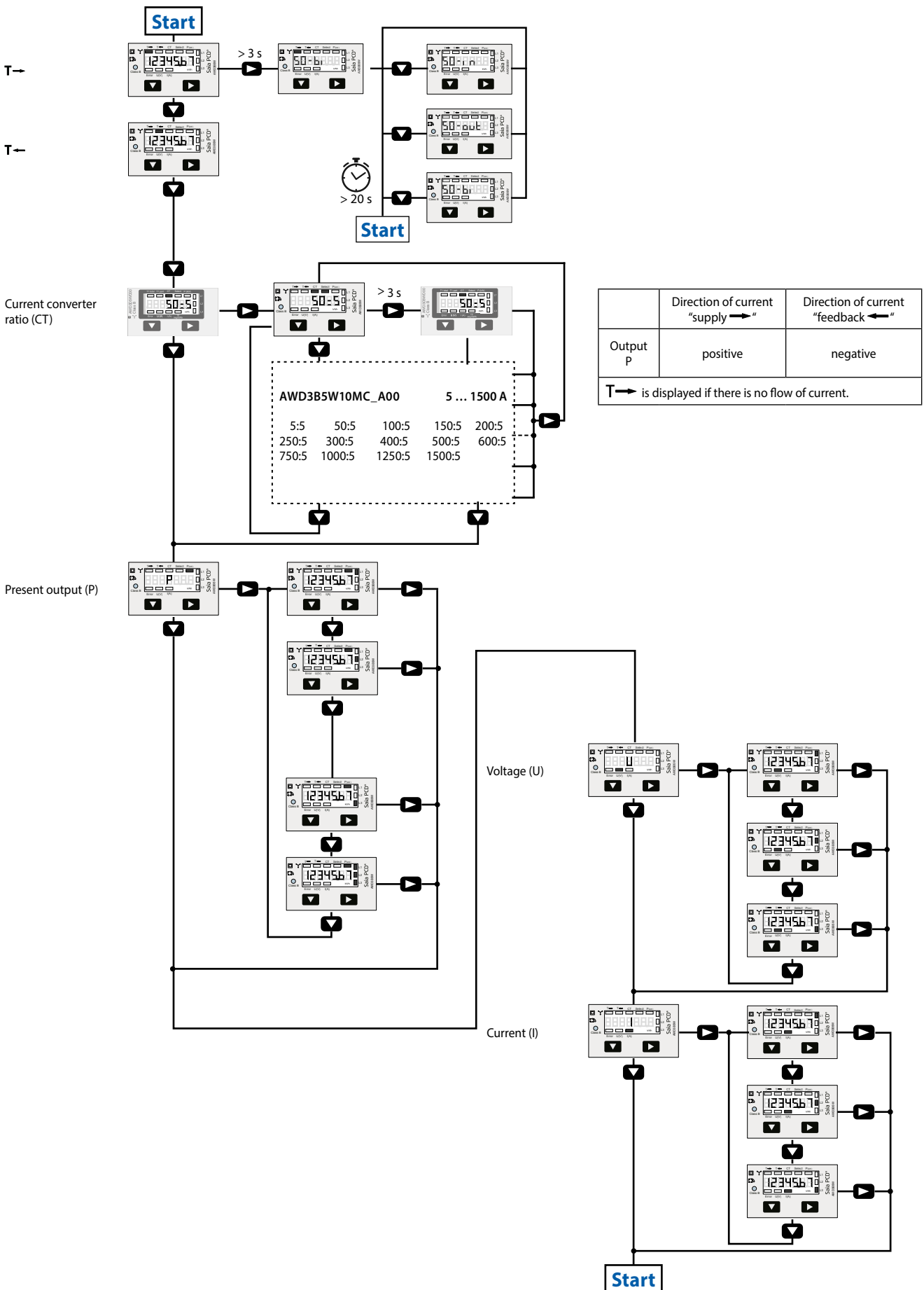

Connection diagram / Method of operation

Energy is added as indicated by the arithmetic operator. Positive output in the meter indicates that energy is being supplied, while negative output indicates that energy is being delivered. The energy measurement is carried out in accordance with mode 2, is balanced.

If the supply of energy (P positive) is greater than the delivery of energy (P negative), the counter T → increases.

The LED is OFF and only switches on if there is a pulse.

If the delivery of energy is greater than the supply of energy, the counter T ← increases.

In this case the LED is ON and only switches off if there is a pulse.

The S0 output can be configured.

S0 IN: S0 pulses only for consumption

S0 OUT: S0 pulses only for feeding back

S0 BI: S0 pulses for both directions of current

Method of operation with direction of current «supply →»

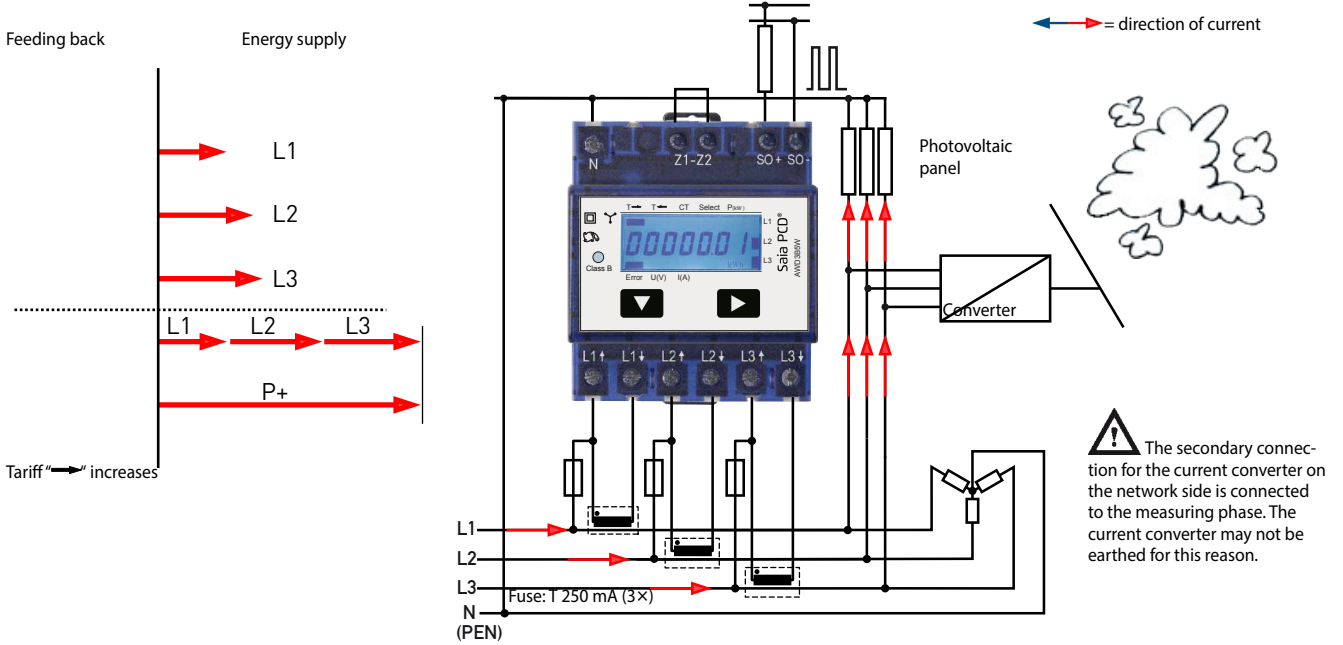

Mode of operation of the LED

LED

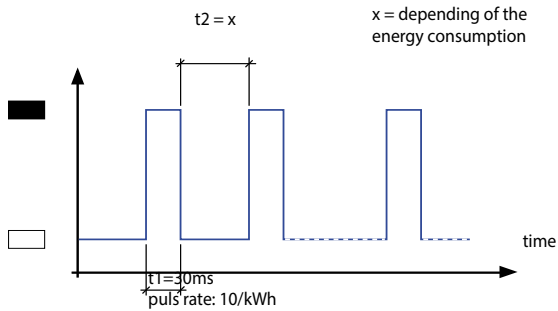

S0 output: S0 BI parameterized

S0-output

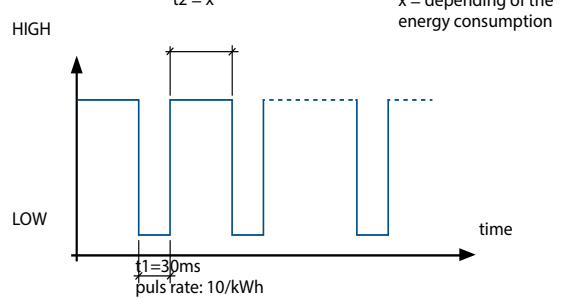

Method of operation with direction of current «supply →» and «feeding back ←»

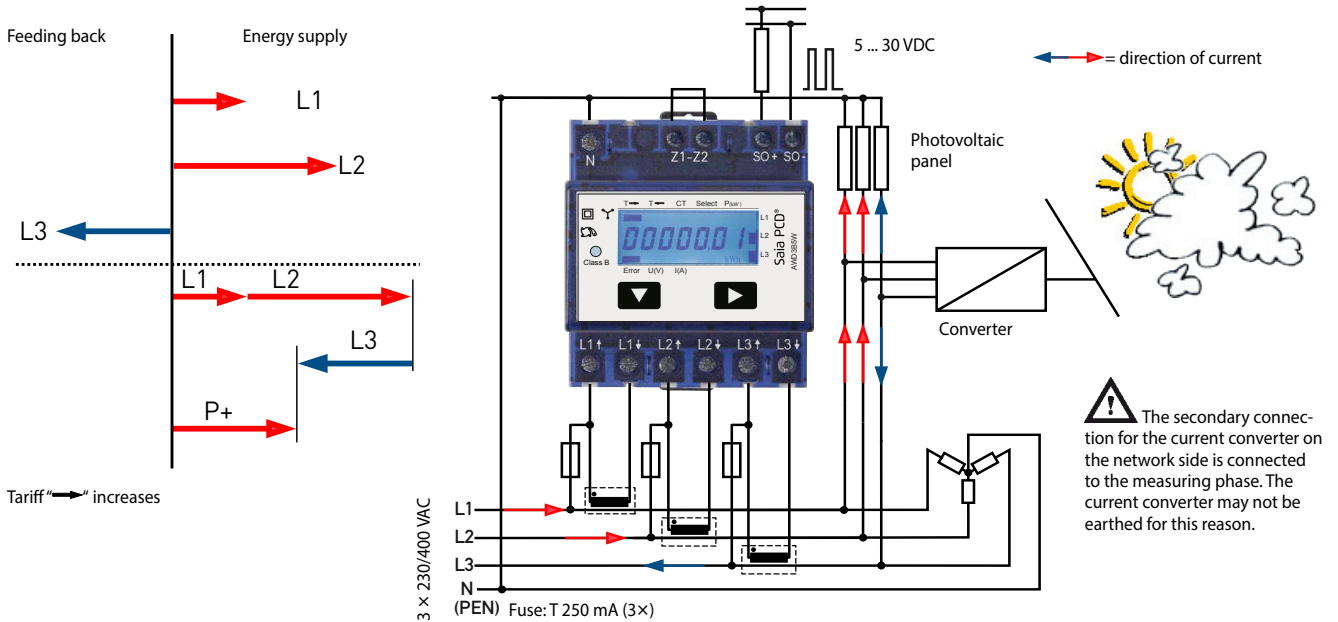

Mode of operation of the LED

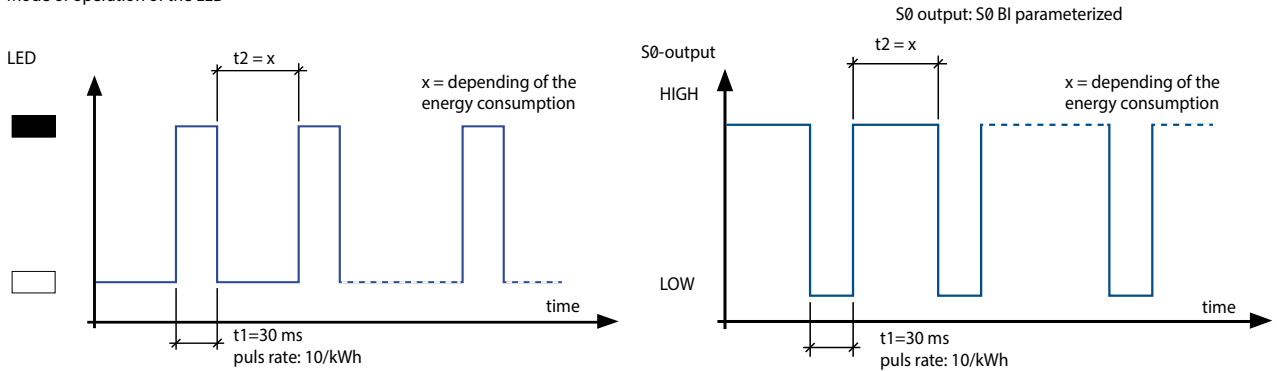

Method of operation with direction of current «feeding back ←»

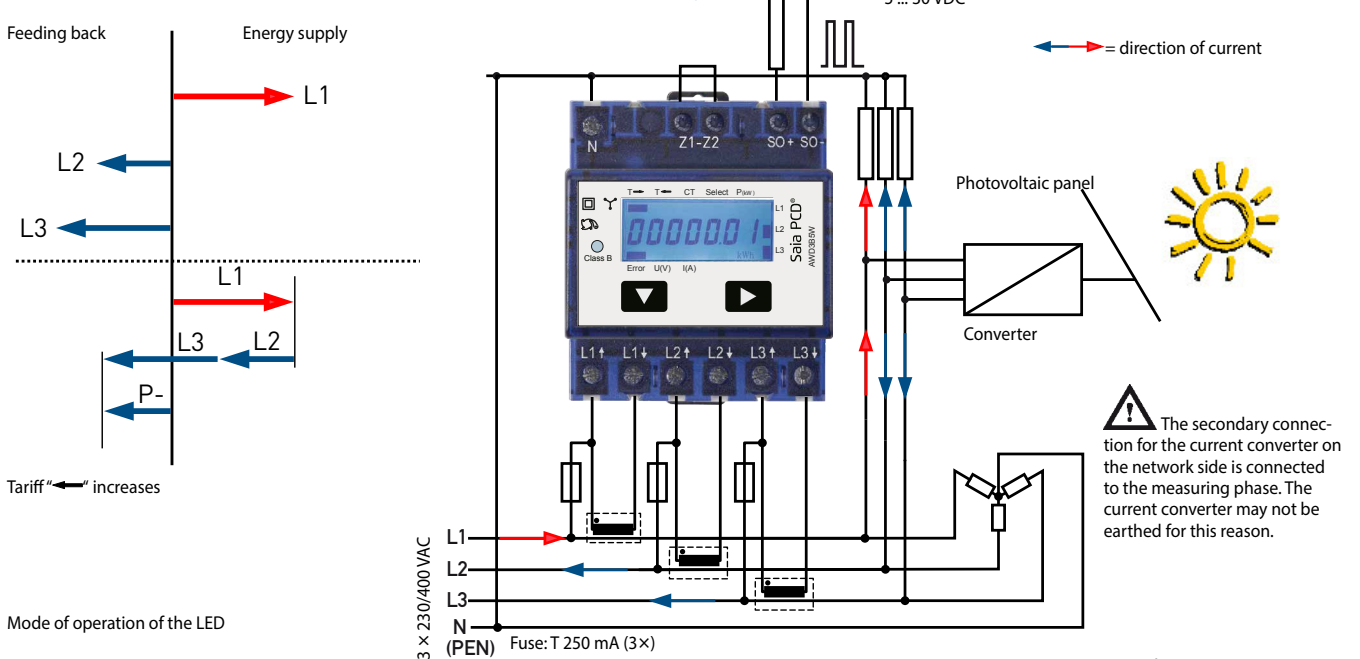

Mode of operation of the LED

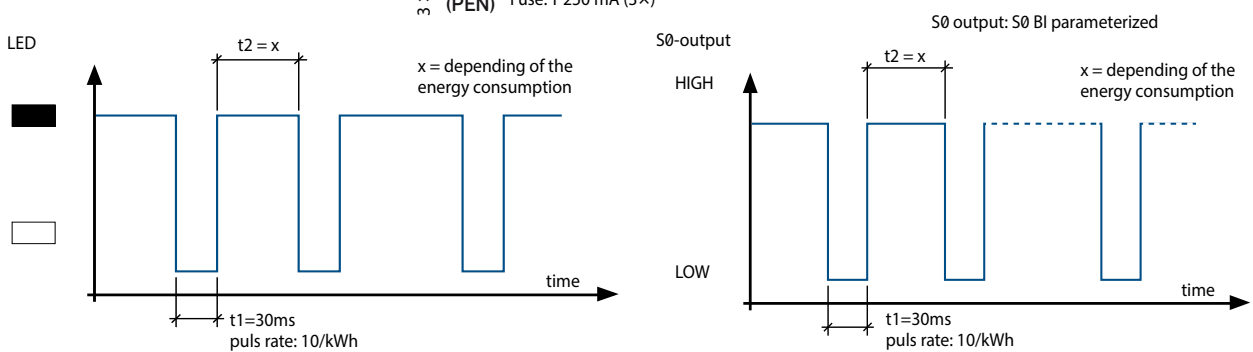

Saia-Burgess Controls AG

Bahnhofstrasse 18 | 3280 Murten, Switzerland

T +41 26 580 30 00 | F +41 26 580 34 99

www.saia-pcd.com

support@saia-pcd.com | www.sbc-support.com