

# Honeywell

# VBF2, VBF3 Control Ball Valves With Flanged Connections

## SPECIFICATION DATA

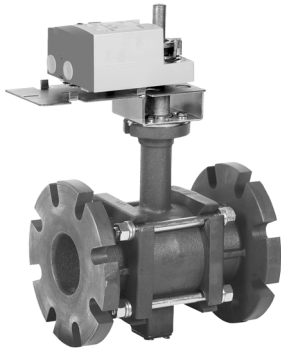

VBF2

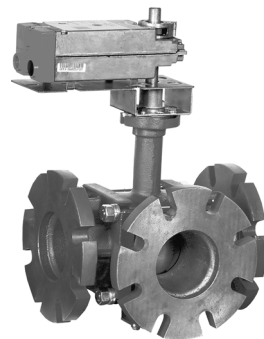

VBF3

## APPLICATION

The VBF2 Two-Way and the VBF3 Three-Way Ball Valve Assemblies, with and without actuators, control hot and chilled water with glycol solutions up to 50% in heating, ventilating, and air conditioning (HVAC) systems to provide two-position or modulating functions.

These valve assemblies can be ordered with or without factory-mounted non-spring return or spring return direct-coupled actuators (DCA).

## FEATURES

All Models

- Sizes from 4 to 6 inch with ANSI Class 125 flanged connections.
- Equal percentage or linear flow characteristics.
- Choice of four, factory-installed actuation control schemes: Floating, Modulating (2-10 V), Spring Return 24V 2-Position, Spring Return Modulating/Floating.
- Field configurable for normally open or normally closed fail-safe position.
- Optional NEMA 3R (IP54) rated enclosure for outdoor applications.
- Option of four actuator mounting positions on the valve.
- Wide range of  $C_v$  choices from 91 to 650.
- Valve ball and stem 316 stainless steel.

VBF2 (Two-way)

- ANSI Class IV leakage specification (0.01% of  $C_v$ ).

VBF3 (Three-way)

- Mixing or Diverting control and ANSI Class IV leakage specification (.01% of  $C_v$ ) for all sizes except as noted below.
- VBF3 4 inch with 327  $C_v$ , 5 inch with 400  $C_v$ , and 6 inch with 650  $C_v$ .
  - Mixing control only.
  - Class IV (.01% of  $C_v$ ) leakage A to AB.
  - Class III (.1% of  $C_v$ ) leakage B to AB.
- Globe valve A-B-AB flow pattern (side B port).



62-3078-06

# SPECIFICATIONS

**Table 1. Model Selection.**

| Valve                                     | Fitting  | Body / Flow | Size     | C <sub>v</sub> | T/P      | Trim     | Enclosure | Actuator |
|---|----------|-------------|----------|----------------|----------|----------|-----------|----------|
| VB = valve, ball                          |          |             |          |                |          |          |           |          |
| F = Flanged                               |          |             |          |                |          |          |           |          |
| 2 = 2 way                                 |          |             |          |                |          |          |           |          |
| 3 = 3 way                                 |          |             |          |                |          |          |           |          |
| inc S.I. metric<br>h                      |          |             |          |                |          |          |           |          |
| J 4 DN100                                 |          |             |          |                |          |          |           |          |
| K 5 DN125                                 |          |             |          |                |          |          |           |          |
| L 6 DN150                                 |          |             |          |                |          |          |           |          |
| S C <sub>v</sub> Designator: See Table 2. |          |             |          |                |          |          |           |          |
| T   |          |             |          |                |          |          |           |          |
| U   |          |             |          |                |          |          |           |          |
| 1   |          |             |          |                |          |          |           |          |
| 2   |          |             |          |                |          |          |           |          |
| 3   |          |             |          |                |          |          |           |          |
| 4   |          |             |          |                |          |          |           |          |
| 5   |          |             |          |                |          |          |           |          |
| 6   |          |             |          |                |          |          |           |          |
| 7   |          |             |          |                |          |          |           |          |
| 1 = ANSI Valve construction               |          |             |          |                |          |          |           |          |
| S = Stainless Steel                       |          |             |          |                |          |          |           |          |
| O = no enclosure                          |          |             |          |                |          |          |           |          |
| R = NEMA 3R enclosure                     |          |             |          |                |          |          |           |          |
| X = no actuator                           |          |             |          |                |          |          |           |          |
| A = NSR, Floating                         |          |             |          |                |          |          |           |          |
| B = NSR, Modulating                       |          |             |          |                |          |          |           |          |
| C = SR, 2-Position, 24 Vac                |          |             |          |                |          |          |           |          |
| D = SR, Floating /Modulating              |          |             |          |                |          |          |           |          |
| <b>VB</b>                                 | <b>F</b> | <b>2</b>    | <b>A</b> | <b>B</b>       | <b>1</b> | <b>S</b> | <b>O</b>  | <b>A</b> |

**Dimensions:** Refer to Figures 1 and 2.

**Body Style:** Two-way ball valve, straight-through flow, full or reduced port using laser-milled stainless steel control ball.

Three-way ball valve, A-B-AB characterized flow, laser-milled stainless steel control ball.  
Combination ANSI 125/PN16 flanged connections.

**Body Size:** 4 to 6 inch (DN100, DN125, DN150).

**Flow Capacity:** See Table 2.

**Body Pressure Rating (maximum):**  
240 psi (1655 kPa) at 250° F (121° C).

**Controlled Medium:** Water or Glycol solutions up to 50%.  
Not suitable for combustible gases. For closed loop systems only. Not for use in open loop systems.

**Fluid Temperature Range:** -22 to +250° F (-30 to +121° C).

**Maximum Differential Pressure:** Refer to Table 3.

**Flow Characteristics:**  
Two-way: Equal Percentage.  
Linear with full port.  
Three-way: Port A to AB: Equal Percentage.  
Port B to AB: Linear with 20% reduced flow capacity.

**Rangeability:** 500:1 minimum.

**Mounting:** Bolt holes conform to ANSI B16.1.

**Materials:**  
Body: Cast Iron ASTM A395, 60-40-18  
Ball and Stem: 316 Stainless Steel.  
Stem Seals: EPDM O-Rings.  
Ball Seals: Teflon® Seals

**Approvals/Standards:**  
Valves: ANSI close-off/leakage.  
2-way - ANSI Class IV leakage  
3-way - ANSI Class IV leakage (except as noted below)  
3-way - A to AB; ANSI Class IV leakage.  
B to AB; ANSI Class III leakage on 4 inch with 327 C<sub>v</sub>, 5 inch with 400 C<sub>v</sub>, and 6 inch with 650 C<sub>v</sub>.  
Actuators: Non-Spring Return, Floating or Modulating  
UL/cUL.  
UL873 Plenum Rating, File No. E4436; Guide No. XAPX.  
CE  
Spring Return 2-Position, 24 Vac or Floating/Modulating  
UL/cUL  
UL873 Plenum Rating, File No. E4436; Guide No. XAPX.  
CE  
C-TICK

**Accessories:**  
SW2-US actuator auxiliary switch kit.

**Table 2. Flanged Valves C<sub>v</sub> Values.**

| Pipe Size | C <sub>v</sub> Designator* |     |     |     |     |                  |     |     |     |     |
|-----------|----------------------------|-----|-----|-----|-----|------------------|-----|-----|-----|-----|
|           | S                          | T   | U   | 1   | 2   | 3                | 4   | 5   | 6   | 7   |
| 4 in.     | 91                         | 118 | 152 | 197 | 254 | 327 <sup>a</sup> |     |     |     |     |
| 5 in.     |                            |     | 144 | 185 | 240 | 309              | 400 |     |     |     |
| 6 in.     |                            |     |     | 208 | 268 |                  | 346 | 441 | 577 | 650 |

<sup>a</sup> For three-way valves only  
\* Maximum flow is 700 gpm (44 L/s)

## Application Notes

### Required Torque

Both Honeywell non-spring return and spring return direct coupled actuators can be utilized with the VBF2 and VBF3 valves. See Table 3, which lists the close-off pressure rating for the valves with the different torque actuators. Larger torque actuators may be used, but there is no increase in close-off pressure rating.

**Table 3. Close-off Pressure Ratings**

| Valve Size | Actuator Torque      |                       |                                     |                       |
|------------|----------------------|-----------------------|-------------------------------------|-----------------------|
|            | 88 in.-lb<br>(10 Nm) | 175 in.-lb<br>(20 Nm) | 175 in.-lb<br>(20 Nm)<br>2-position | 300 in.-lb<br>(34 Nm) |
| 4 in.      | 70*                  | 70                    | 70                                  | 70                    |
| 5 in.      | 70*                  | 70                    | 70                                  | 70                    |
| 6 in.      |                      |                       | 70*                                 | 70*                   |

\* This is the factory-installed actuator rating.

## Flow Characteristics

VBF2 Two-Way Ball Valves have:

- an equal percentage flow characteristic.

VBF3 Three-Way Ball Valves have:

- between ports A and AB: an equal percentage flow characteristic.
- between ports B and AB: a linear flow characteristic.

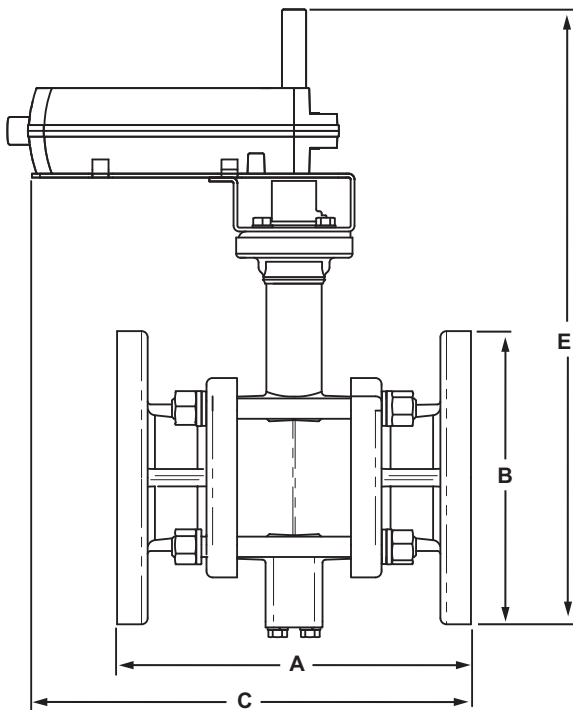

| Size (in.) | Model Number | A in. (mm)   | B in. (mm) | C in. (mm)   | D (depth) (not shown) in. (mm) | E in. (mm)   | Wt. lb (kg) |
|------------|--------------|--------------|------------|--------------|--------------------------------|--------------|-------------|
| 4          | VBF2J        | 11 (278)     | 9 (229)    | 13-1/4 (337) | 9 (229)                        | 18-3/4 (476) | 65 (31)     |
| 5          | VBF2K        | 12-3/8 (352) | 10 (254)   | 14-1/4 (362) | 10 (254)                       | 19 (483)     | 75 (34)     |
| 6          | VBF2L        | 13-7/8 (352) | 11 (278)   | 15-1/8 (384) | 11 (278)                       | 19-7/8 (505) | 90 (41)     |

M13732

**Fig. 1. VBF2 Dimensions in inches (mm).**

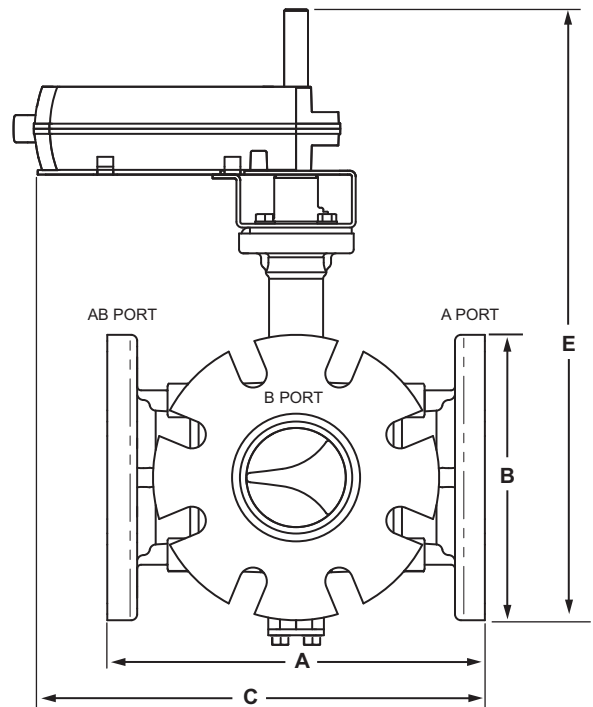

| Size (in.) | Model Number | A in. (mm)   | B in. (mm) | C in. (mm)   | D (depth) (not shown) in. (mm) | E in. (mm)   | Wt. lb (kg) |
|------------|--------------|--------------|------------|--------------|--------------------------------|--------------|-------------|
| 4          | VBF3J        | 11-7/8 (278) | 9 (229)    | 14-1/8 (337) | 10-3/8 (229)                   | 18-1/2 (470) | 75 (34)     |
| 5          | VBF3K        | 13-7/8 (352) | 10 (254)   | 15-1/8 (362) | 12 (254)                       | 19-3/8 (483) | 90 (41)     |
| 6          | VBF3L        | 15-7/8 (403) | 11 (278)   | 16-1/8 (410) | 13-3/8 (521)                   | 20-1/2 (521) | 105 (48)    |

M13733A

**Fig. 2. VBF3 Dimensions in inches (mm).**

## TYPICAL SPECIFICATIONS

### Actuated Ball Valve

Valve housing shall consist of cast iron, rated at no less than 240 psi at 250° F (121° C). Valve housing shall have ANSI Class 125 flanges. Valve ball shall consist of stainless steel with parabolic ports to make flow control equal percentage. Valve shall have a blow-out proof stem with two EPDM O-Rings. Valve shall have EPDM O-Rings behind ball seals to allow for a minimum close-off pressure of 70 psi with 88 in.-lbs of torque for 4 and 5 inch valves. Six inch valves shall require actuators with 140 in.-lbs of torque for flow rates under 700 gpm. Valve shall be available with a minimum of 5 unique  $C_V$  values for each size. 3-Way Valve: Bypass  $C_V$  shall be 80% of Through  $C_V$ .

*Honeywell® is a registered trademark of Honeywell International.*

*Teflon® is a registered trademark of E I DuPont de Nemours.*

### Valve Actuator

Control valve actuator shall accept analog modulating floating (tri-state), or two-position signal as indicated in the control sequence. Actuators shall be by Honeywell. Actuator shall provide minimum torque required for full valve shutoff position. Wiring terminals shall be provided for installation to control signal and power wiring.

### ACCESSORIES

Identification tags shall be available for all valves; tags shall be indelibly marked with  $C_V$ , model number and location.

By using this Honeywell literature, you agree that Honeywell will have no liability for any damages arising out of your use or modification to, the literature. You will defend and indemnify Honeywell, its affiliates and subsidiaries, from and against any liability, cost, or damages, including attorneys' fees, arising out of, or resulting from, any modification to the literature by you.

### Honeywell Building Technologies

In the U.S.:

Honeywell

715 Peachtree Street NE

Atlanta, GA 30308

customer.honeywell.com

buildingcontrols.honeywell.com

# Honeywell

® U.S. Registered Trademark  
©2020 Honeywell International Inc.  
62-3078-06 M.S. Rev. 10-20  
Printed in United States