



SPECIFICATION DATA

Q605A, B, D, AND E DAMPER LINKAGES

application: The Q605 Damper Linkages connect a Modutrol* Motor to a standard damper (or dampers) to control the flow of air through ducts. The various models permit the motor to be mounted inside or outside the duct, and on either side of the damper. The Q605B Linkages include an adapter for reducing the motor crank arm radius so that the linkage is adjustable, providing maximum damper openings from 40 to 90 degrees.

An adapter assembly, available as part number 104643A, fastened to the crank arm of a Modutrol

specifications:

MODELS:

- Q605A Bracket and Linkage** — Used to connect a Modutrol motor to a louver damper when the motor mounts externally on the duct. Consists of:
- Motor mounting bracket.
 - Crank arm for 1/2 in. diameter damper shaft.
 - Ball joints (2) for 5/16 in. diameter push rod.
 - Motor crank arm.*

- Q605B Bracket and Linkage** — Used to connect a Modutrol motor to a louver damper when the motor mounts internally on the damper frame. Consists of:
- Motor mounting bracket.
 - Adapter arm for motor crank arm.
 - Ball joints (2) for 5/16 in. diameter push rod.
 - Motor crank arm.*

- Q605D Bracket and Linkage** — Used to connect one Modutrol motor to two louver dampers when the motor mounts externally on the duct. Consists of:
- Motor mounting bracket.
 - Crank arms (3) for 1/2 in. diameter damper shaft.
 - Ball joints (4) for 5/16 in. diameter push rod.
 - Motor crank arm.*

- Q605E Linkage** — Used to connect a Modutrol motor to a louver damper when the motor mounts directly on a wall or outside of the duct without using a mounting bracket. Consists of:
- Crank for 1/2 in. diameter damper shaft.
 - Ball joints (2) for 5/16 in. diameter push rod.
 - Motor crank arm.*

motor controls . . .

- two dampers too far removed from each other to be controlled by standard linkages.
- two dampers acting at right angles.
- three dampers, size permitting, ordinarily uncontrollable with standard linkages.

construction: The Q605 Damper Linkage consists of a bracket and linkage to connect a Modutrol motor to a louver damper. Ball and socket joints are furnished for connecting the push rod to the crank and damper arm. Motor mounting brackets are furnished with all models except the Q605E. The push rods, not included with the linkage, must be ordered separately (see Specification section).

*For damper shafts other than 1/2" dia., order separately a crank arm with proper dia. hub. (26025B for 3/8" and 27174B for 7/16")

PUSH RODS: Push rods, not included in the linkages, must be ordered separately. Available push rods are:

- A27520C — 12 in. long.
- A27520D — 15 in. long.
- A27520E — 18 in. long.
- A27520G — 24 in. long.
- A27520K — 36 in. long.
- A27520L — 48 in. long.

All push rods are 5/16 in. diameter.

The Q605B Linkage always requires A27520. Other linkages normally require a push rod (or rods) of a standard length, as given below. If it is impossible to determine the necessary length at ordering, choose a long rod and cut to length.

LINKAGE	PUSH ROD NORMALLY USED
Q605A	A27520E
Q605B	A27520D
Q605D	One A27520E and one A27520K
Q605E	A27520E

SPECIAL ACCESSORIES AVAILABLE:

14000716-003 Internal Mount Linkage Kit.

WHEN SPECIFYING, INDICATE:

- Linkage model number.
- Push rod part number.
- Special Accessories desired, if any.

EXTERNAL MOUNTING BRACKET NO. 101662A
FURNISHED WITH Q605A AND -D LINKAGES

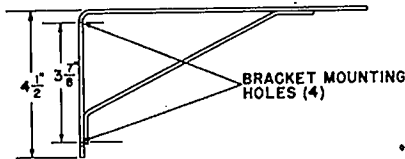
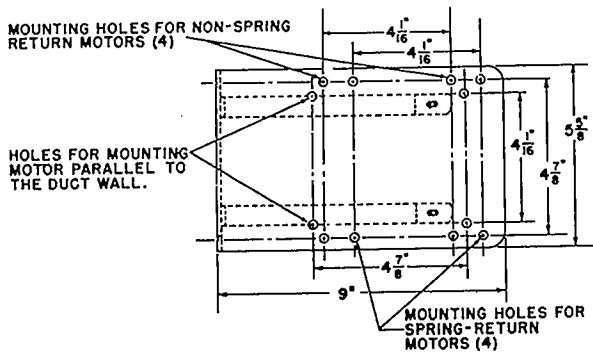

ADAPTER ARM
NO.102931

BALL JOINT NO. 27518

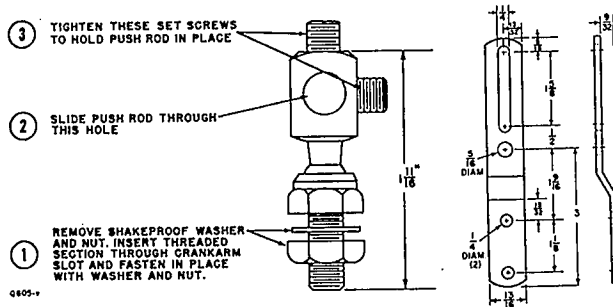

CRANK ARMS

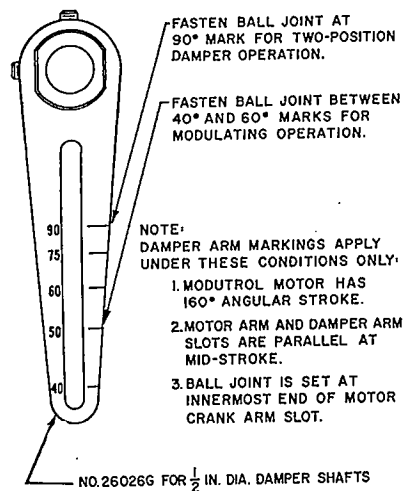

INTERNAL MOUNTING BRACKET NO. 308765
FURNISHED WITH Q605B LINKAGES

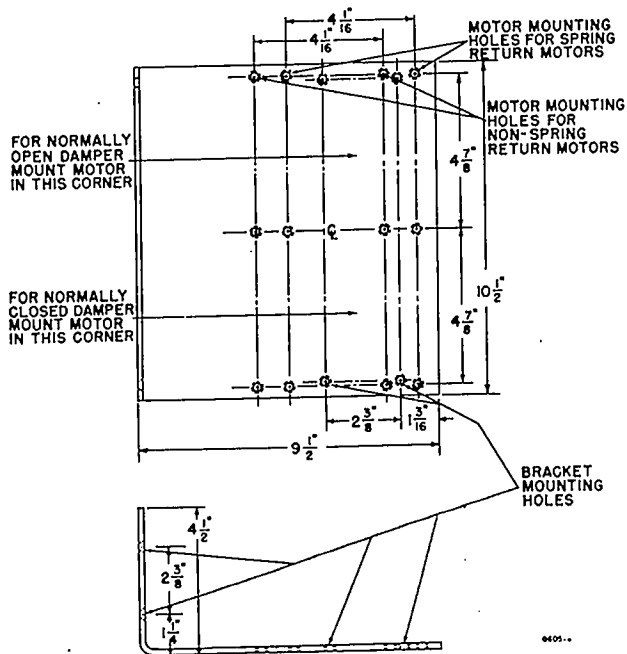

MOTOR CRANK ARM ADAPTER ASSEMBLY
NO. 104643A

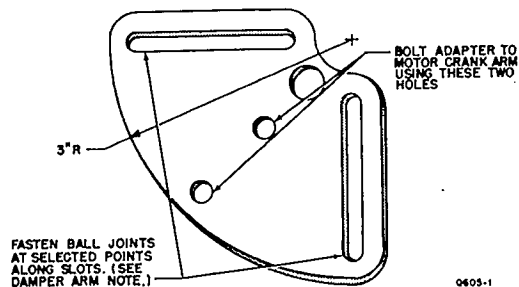

Fig. 1 — Approximate Dimensions of Linkage Components.

Mounting and crank-arm setting instructions are furnished with the Modutrol Motor.

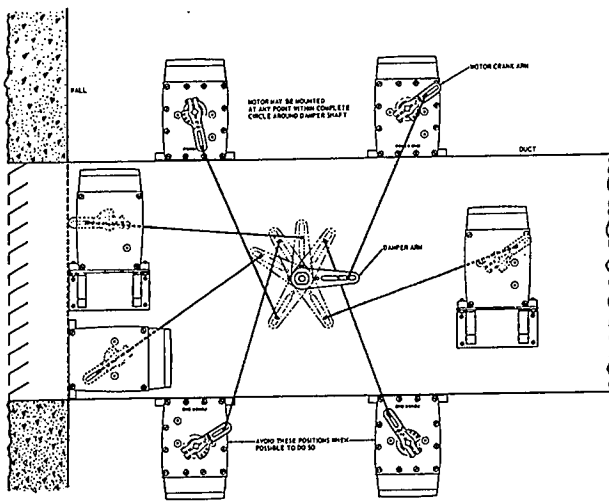

Fig. 2 — Motor Mounting Positions Using Q605 Linkages.

typical operation: For two-position control, set the ball joint at the 90 degree mark on the damper crank arm. The damper will be either fully open or fully closed, depending on the demand of the controller.

For good proportional control, the damper should not open more than approximately 50 degrees. Opening the damper between 45 degrees and 60 degrees allows 96% of the maximum air volume to pass through the damper. Any additional opening of the damper has little or no effect.

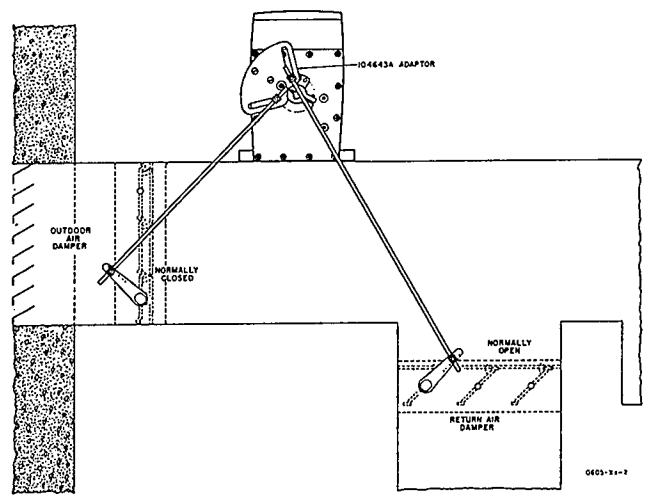

Fig. 3 — Typical Installation Using No. 104643A Adapter.