

Guidelines:

Proper Installation of Outdoor

SpectrAlert Advance[®] Audible Visible Devices



Designed to be watertight and to operate in a wide temperature range, SpectrAlert Advance outdoor audible visible (AV) appliances are an ideal solution for fire, general signaling, mass notification, or emergency communication system (ECS) projects that require exterior notification or notification in areas where ambient conditions may exceed the environmental tolerances of typical indoor AV devices. While SpectrAlert Advance outdoor devices are easy to install, several installation procedures and guidelines unique to outdoor models must be followed in order for the devices to perform as intended in outdoor environments.

As a supplement to the installation manuals System Sensor includes with every product, this white paper provides an overview of the proper installation procedures to follow when installing outdoor devices. Please refer to the installation manual included with your product or accessible at www.systemsensor.com/av for more complete installation instructions. If these instructions are not followed, your notification appliance may not perform as intended.

SpectrAlert Advance Outdoor Product Line

The SpectrAlert Advance outdoor product line includes two groups of devices: standard and replacement (-R) models. All standard devices (Table 1) ship with the required plastic outdoor back box.

Replacement (-R) models (Table 2) do not ship with the outdoor back box. These models are designed specifically for use in flush-mount applications and are to be used with the SpectrAlert Advance WTP series of weatherproof plates or our custom designed series of metal weatherproof back boxes-SA-WBB for horn, strobes and horn/strobes and MWBB for Speakers and Speaker/Strobes (Table 3).

Table 1 – Standard Outdoor Models

Horns	Strobes	Horn Strobes	Speakers	Speaker Strobes
HRK	SRK	P2RK	SPWK	SPSWK
	SRHK	P2RHK	SPRK	SPSRK
	SWK	P2WK	SPCWK	SPSRHK
	SWHK	P2WHK		SPSCWK
	SCRK	P2RHK-120		SPSCWHK
	SCRHK	P2RK-P		SPSWK-P
	SCWK	P2RHK-P		SPSRK-P
	SCWHK	P2WK-P		SPSWK-CLR-ALERT
	SRK-P	P2WHK-P		SPSCWHK-P
	SRHK-P	P4RK		SPSCWK-CLR-ALERT
	SWK-P	P4WK		
	SWHK-P	PC2RK		
		PC2RHK		
		PC2WK		
	PC2WHK			
	PC4WK			

Table 2 – Replacement (-R) Outdoor Models (for use with WTP weatherproof plates) or SA-WBB and MWBB metal outdoor back boxes

Horns	Strobes	Horn Strobes	Speakers	Speaker Strobes
HRK-R	SRK-R	P2RK-R	SPWK-R	SPSWK-R
	SWK-R	P2RHK-R	SPRK-R	SPSRK-R
		P2WK-R	SPCWK-R	SPSCWK-R
		P2WHK-R		
		P4RK-R		

SpectrAlert Advance also provides a full range of accessory back boxes and weatherproof mounting plates for outdoor AV appliances (Table 3). Note that specific back box and mounting plate models are designed to work with specific device types.

Table 3 – Outdoor Back Boxes and Weatherproof Mounting Plates

Metal Outdoor Back Boxes for Horns, Strobes, and Horn Strobes	
SA-WBB	Wall Mount Metal Outdoor Back Box, Red
SA-WBBC	Ceiling Mount Metal Outdoor Back Box, Red
SA-WBBW	Wall Mount Metal Outdoor Back Box, White
SA-WBBCW	Ceiling Mount Metal Outdoor Back Box, White
Weatherproof Outdoor Mounting Plates for Horns, Strobes, and Horn Strobes	
WTP	Flush Mount Weatherproof Plate, Red
WTPW	Flush Mount Weatherproof Plate, White
Metal Outdoor Back Boxes for Speakers and Speaker Strobes	
MWBB	Wall Mount Metal Outdoor Back Box, Red
MWBBW	Wall Mount Metal Outdoor Back Box, White
MWBBCW	Ceiling Mount Metal Outdoor Back Box, White
Weatherproof Outdoor Mounting Plates for Speakers and Speaker Strobes	
WTP-SP	Flush Mount Weatherproof Plate, Red
WTP-SPW	Flush Mount Weatherproof Plate, White

Proper Installation of Outdoor Devices

SpectrAlert Advance outdoor products (model numbers end in “K” or “K-R” for replacement models) come in red and white, are available in wall- or ceiling-mount versions, and may be used indoors or outdoors. Standard products must be installed using the proper SpectrAlert Advance weatherproof back box.* Plastic weatherproof back boxes ship with all “K” series devices. Metal weatherproof back boxes are also available as an accessory for jurisdictions that require the use of metal back boxes (see Table 3). **Do not attempt to use boxes other than those specified for use with your product.** If you have to replace a device, it is strongly recommended that you replace the outdoor back box as well.

**An installed weatherproof back box should not be left without an installed unit for extended periods of time to avoid water accumulation and potential damage.*

Installing the SpectrAlert Advance Weatherproof Back Box

The weatherproof back box includes small screw plugs to mount directly to the wall, ceiling, or to a weatherproof electrical box. If the small screw knockouts are removed, they must be sealed with an outdoor or marine rated silicone. For horns, strobes, and horn/strobes, you can use the center holes for a single gang box and the four outer holes for a double gang box. Speakers and speaker strobes can only be mounted to a 4x4 weatherproof electrical box.

The back box also includes threaded holes on the top and bottom of the back box for 3/4-inch NPT conduit adapters. In addition, conduit knockouts in the back of the back box are provided for 3/4-inch NPT conduit entry. When using the rear conduit entry holes, the unused holes on the top and bottom of the outdoor back box must be properly sealed. Threaded plugs and O-rings are provided with the product for this purpose. It is recommended to put Teflon tape on the conduit plug to ensure a proper seal.

Water may compromise the back box due to condensation or direct exposure to rain or snow, so it is the responsibility of the installer to make sure that all openings and connections are properly sealed. Even outdoor installations that are protected from direct exposure to rain are still subject to condensation or leakage through hidden areas, such as a soffit. Watertight fittings should be used for all wiring connections (see *Liquid-Tight Connectors and How to Use Them*), including the conduit knockout and screw knockouts on the back of the box.

**In areas where humidity is a concern, we recommend blocking the conduit with minimally expanding foam designed for windows and doors.*

Installing Outdoor Speakers and Speaker Strobes

The plastic weatherproof back box shipped with speakers and speaker strobes is equipped with removable side flanges for mounting. System Sensor recommends securing the back box directly to the wall or ceiling using the flanges. If this approach is not possible or is undesirable for aesthetic reasons, installers can use the small screw plugs on the back of the back box.

Attach the device mounting plate (Figure 1:B) to the weatherproof back box (Figure 1:A) using the four non-painted screws included with the product (Figure 1:C). Hook the tabs on the product housing into the grooves on the mounting plate. Then, swing the product into position to engage the pins on the device with the terminals on the mounting plate. Verify that the tabs on the back of the device are fully engaged with the mounting plate. Finally, secure the device to the mounting plate using the four #8-32x³/₈-inch flat head screws (Figure 1:D).

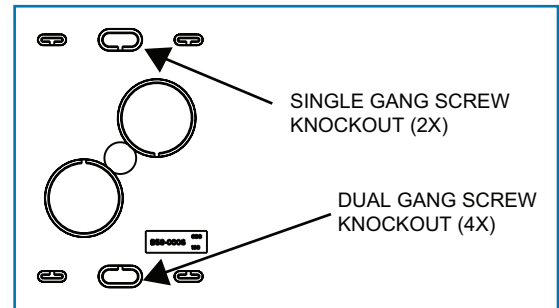
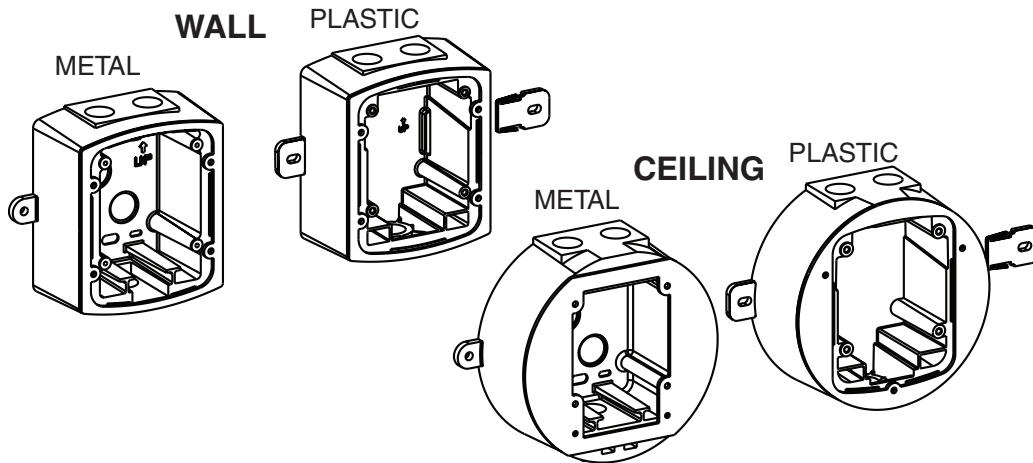

Figure 1 – Mounting Outdoor Speakers and Speaker Strobes to a Weatherproof Back Box



Flush Mounting Outdoor Speakers and Speaker Strobes

The WTP-SP weatherproof plate is for installation with SpectrAlert Advance outdoor replacement (-R) speakers and speaker strobes. This accessory plate enables installers to flush mount an outdoor unit on a number of different surfaces, including brick, ceramic tile, concrete, and masonry brick. Sold separately from the device, the WTP-SP is offered in red and white (WTP-SPW) and is designed for use in both indoor and outdoor applications. The plate is designed specifically to work with the proper SpectrAlert Advance K-series outdoor replacement products (see Speakers and Speaker Strobes in Table 2). The WTP-SP is compatible with 4x4x2 1/8-inch back boxes. **Do not attempt to use this weatherproof plate with devices or back boxes other than those specified for use with this product.**

When installing, attach the device mounting plate to the WTP-SP. Check the orientation of the back box to the WTP-SP plate and observe which holes will be used for mounting the back box. Place the Well Nuts (Figure 2:A) into the two holes that will NOT be used in mounting the WTP-SP to the back box. Place the device mounting plate onto the WTP-SP and secure by tightening the two #8-32x1/2-inch pan head screws (Figure 2:B) into the well nuts. Secure the WTP-SP and device mounting plate assembly to the back box using the two #8-32x1/2-inch pan head screws (Figure 2:C). Tighten the screws until the WTP-SP gasket is evenly compressed around the perimeter at least 50 percent.

Figure 2 – WTP-SP and Device Mounting Plate Assembly and Attachment to Back Box

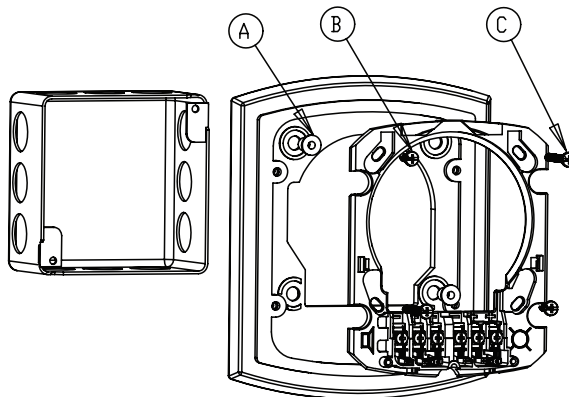

An outdoor-rated silicone caulk (not supplied) may be applied around the WTP-SP to fill in around grout lines or uneven surfaces. It is recommended that the silicone should be added after the plate is attached but before the plate is completely screwed down to the surface. This will provide the best indication as to where to apply the silicone.

Connect the field wiring to the proper terminals. For how to connect the field wiring, please follow the instructions listed in the installation manual supplied with the device.

Next, attach the device to the mounting plate by hooking the tabs on the device housing into the grooves on the mounting plate.

Installing Outdoor Horns, Strobes, and Horn Strobes

The plastic wall-mount back box shipped with these products must be mounted with the internal post (Figure 3:A) in the lower left corner.*

Attach the device mounting plate (Figure 3:B) to the weatherproof back box (Figure 3:C) using the four non-painted screws (Figure 3:D) included with the product. Hook the tabs on the product housing into the grooves on the mounting plate. Then, swing the product into position to engage the pins on the device with the terminals on the mounting plate. Verify that the tabs on the back of the device are fully engaged with the mounting plate. Finally, secure the device to the mounting plate by tightening the single screw attached to the front of the housing (Figure 3:E). For tamper resistance, the captured screw may be replaced with the Torx screw supplied with the device.

*An installed weatherproof back box should not be left without an installed unit for extended periods of time to avoid water accumulation and potential damage.

Figure 3: Mounting Outdoor Horns, Strobes, and Horn Strobes to a Weatherproof Back Box

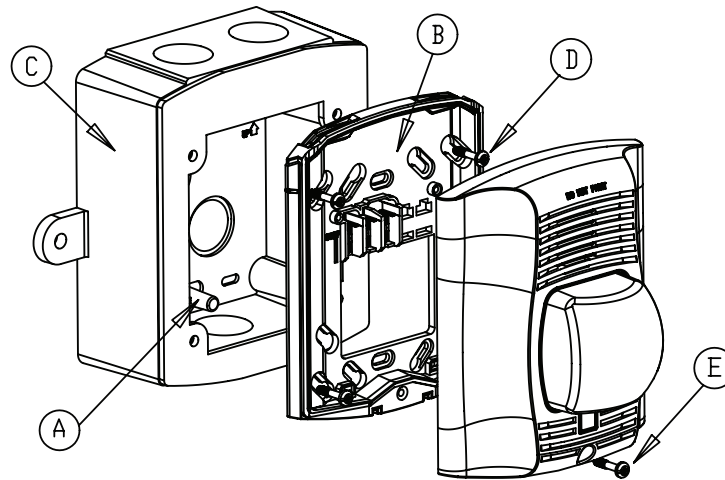

Flush Mounting Outdoor Horns, Strobes, and Horn Strobes

The WTP weatherproof plate is for installation with SpectrAlert Advance outdoor replacement (-R) horns, strobes, and horn strobes. This plate enables installers to flush mount an outdoor unit on a number of different surfaces, including brick, ceramic tile, concrete, and masonry brick. Sold separately from the device, the WTP is offered in red and white (WTPW) and may be used indoors or outdoors. These plates are designed specifically to work with the proper SpectrAlert Advance K-series outdoor replacement products (see Horns, Strobes, and Horn Strobes in Table 2). The WTP is compatible with 4x4x1¼- or 2x4x1½-inch back boxes. **Do not attempt to use this weatherproof plate with devices or back boxes other than those specified for use with this product.**

To install, place the device mounting plate on the WTP and secure it using four #6-32 x 3/8-inch pan head screws (Figure 4:A). Secure the WTP and device mounting plate assembly to the back box using two #8-32 x 2-inch pan head screws when using a 4x4-inch back box (Figure 5:B). When using the 2x4-inch back box, secure the WTP assembly using the two #6-32 x 2-inch pan head screws (Figure 6:C). Tighten the screws until the WTP gasket is evenly compressed around the perimeter at least 50 percent.

An outdoor-rated silicone caulk (not supplied) may be applied around the WTP to fill in around grout lines or uneven surfaces. It is recommended that the silicone be added after the plate is attached but before the plate is completely screwed down to the surface. This will provide the best indication as to where to apply the silicone.

Connect the field wiring to the terminals. Please follow the instruction manual supplied with the device.

Attach the device to the mounting plate by hooking the tabs on the device housing into the grooves on the mounting plate. Then, swing the product into position to engage the pins on the device with the terminals on the mounting plate. Make sure that the tabs on the back are fully engaged with the mounting plate.

Secure the device to the WTP by tightening the single mounting screw (Figure 7:D) attached to the front of the device housing. For tamper resistance, the captured screw may be replaced with the Torx screw supplied with the device.

Figure 4: WTP and Device Mounting Plate Assembly

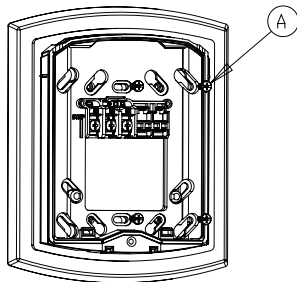

Figure 5: Assembly Attachment to 4x4-inch Back Box

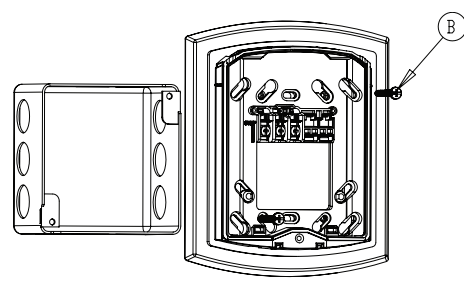

Figure 6: Assembly Attachment to 2x4-inch-Back Box

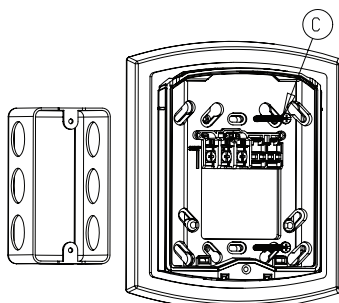
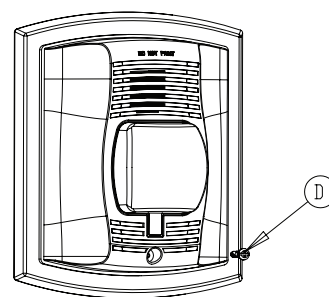

Figure 7: Installed Device and WTP



How to Install Conduit Plugs

In order to maintain watertight performance, any unused conduit openings in SpectrAlert Advance weatherproof back boxes must be sealed using the conduit plugs provided with the product. First, slide the O-ring onto the conduit plug that is shipped with the unit. Install the conduit plug and O-ring in any unused threaded opening on the top and bottom of the back box using Teflon tape or silicone sealant on the plug's threads. Tighten the plug so it compresses the O-ring slightly without pushing it out of place. Do not over tighten. Repeat for any unused threaded openings in the back box.

Liquid-Tight Connectors and How to Use Them

This section provides an overview of the different types of liquid-tight connectors available. It also shows how to use these connectors to provide a watertight seal when connecting conduit to outdoor device weatherproof back boxes — either through the rear knockout holes or through the threaded openings on the top and bottom of the back box.

Types of Liquid-Tight Conduit Connectors

The conduit openings used to bring wire into any SpectrAlert Advance outdoor product should always be protected with a watertight conduit connector. There are several connector options available, including:

- Flexible liquid-tight conduit connector available in metal or plastic
- Rigid PVC conduit connector
- Cord grip connector
- Rigid conduit hub

While the proper SpectrAlert Advance weatherproof back box or mounting plate must be used with the correct product in order for the installation to remain watertight, each of the connectors above can be used in the threaded conduit openings or the rear knockouts as appropriate to the installation.

For example, when a System Sensor outdoor notification product is installed properly in conjunction with the appropriate plastic or metal outdoor back box, it will provide a NEMA 4X rating. However, when a rear knockout is removed from the back box, the product no longer maintains this rating unless a NEMA 4X-rated liquid-tight conduit connector is used.

The use of silicone sealant in the rear knockouts or threaded conduit openings is **NOT** recommended in lieu of using a liquid-tight connector or the provided conduit plugs. This approach will result in an unapproved installation that may not have the required watertight properties.

In applications where local codes do not require product wiring to be installed in conduit, it is recommended that a watertight cord grip connector or a watertight connector with a small length of conduit be used when using the rear knockouts to maintain a watertight seal.

How to Install Liquid-Tight Conduit Connectors in Rear Knockouts

To install a liquid-tight conduit connector, first remove a rear knockout from the metal weatherproof back box by placing the blade of a flat blade screwdriver along the edge of the slot and striking the screwdriver as you slowly work the blade around the slot.

Insert the liquid-tight conduit connector into the knockout opening. Make sure that the connector's gasket is in between the connector and the back box. If a gasket is not provided with the connector, follow the manufacturer's instructions on how to use the connector in a knockout (an O-ring may need to be purchased separately). Attach the conduit connector to the conduit per the manufacturer's instructions. Next, tighten the conduit connector nut on the inside of the back box and then secure the weatherproof back box to the mounting surface.

Remember to plug any unused conduit openings with the conduit plugs provided (see *How to Install Conduit Plugs*).

How to Install Liquid-Tight Conduit Connectors in Threaded Openings

To install a liquid-tight conduit connector, first secure the weatherproof back box to the mounting surface. Thread the liquid-tight conduit connector into a threaded opening following the connector manufacturer's instructions for liquid-tight applications (this may require the use of Teflon tape or another thread sealant). Finally, connect the conduit to the connector per the manufacturer's instructions.

Remember to plug any unused conduit openings with the conduit plugs provided (see *How to Install Conduit Plugs*).

Figure 8: Liquid-Tight Connectors

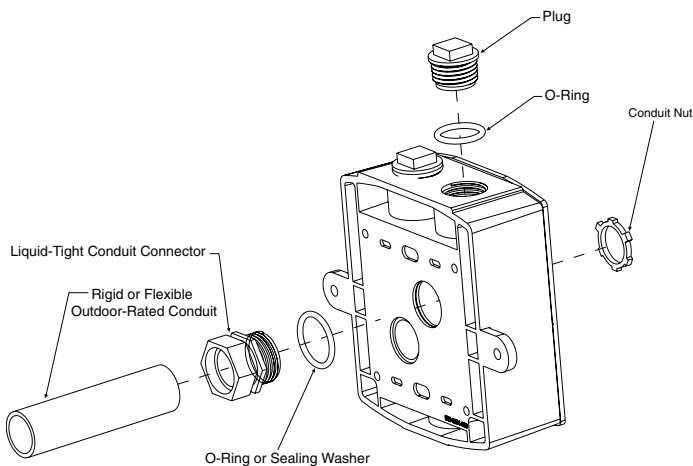
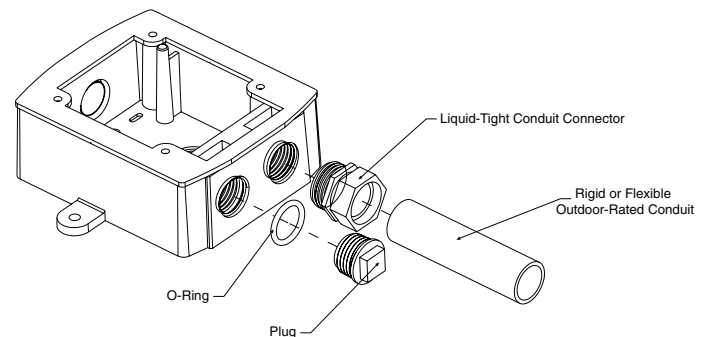

Figure 9: Install in Top Threaded Openings



Installation Gallery

This section includes a gallery of outdoor AV appliance installations to provide visual highlights of proper and improper installation methods. See the explanatory caption below each image for more information.

Proper Installations



A watertight fitting has been properly used to run conduit into the bottom opening of the weatherproof back box.



A liquid-tight connector has been properly used to run conduit into a weatherproof back box.



Silicone caulk may be used to seal the space between the mounting surface and the back box. However, silicone does not replace the need to use liquid-tight connectors when wiring the device through the rear conduit openings (not shown).



This conduit plug has been properly installed with the provided gasket compressed between the plug and the back box. Teflon tape has also been wrapped around the plug's threads (not shown).

Improper Installations



This gasket has been installed incorrectly, resting on top of the conduit plug rather than being compressed between the plug and the back box.



Silicone caulk has been used improperly in place of a conduit plug. Silicone caulk has not been appropriately applied to seal the space between the rough wall surface and the back box.

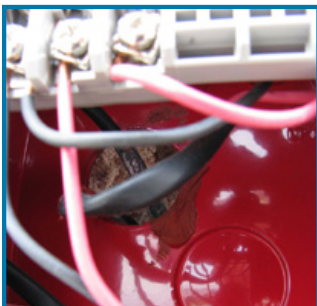

A conduit connector has not been used to run wiring into the back opening. This provides a path for water to enter the device.



Silicone caulk has been used improperly between the product and the gasket. A weep hole has been drilled into the bottom conduit plug. Drilling holes into the bottom conduit plug is not recommended.

For more information, please contact:
System Sensor
3825 Ohio Avenue
St. Charles, Illinois 60174
1-800-sensor2
www.systemsensor.com

