



Environmental Combustion and Control

**Stryker BACnet VAV Wizard Configuration Guide (WEBs-N4)**

May 2016



31-00104-01



# Table of Contents

<b>INTRODUCTION.....</b>	<b>7</b>
Stryker™ BACnet VAV Controller .....	7
WEBStation-N4™ .....	7
BACnet VAV Configuration Wizard .....	7
Control Application.....	8
Control Provided.....	10
VAV Configuration Requirement .....	10
Products Covered.....	10
Organization of the manual.....	10
<b>CONFIGURATION OF VAV CONTROLLER.....</b>	<b>11</b>
Installation.....	11
Installation of WEBStation-N4™ Tool .....	11
Installation of Stryker BACnet VAV Wizard.....	12
Getting Started .....	12
How to configure VAV Configuration Wizard User interface .....	15
VAV Configuration Wizard .....	22
Field description for VAV Configuration Wizard.....	23
CONFIGURATION.....	24
General Settings.....	24
Set Time During Download .....	26
Daylight Savings Settings .....	26
VAV Outputs.....	27
Fan Type.....	39
Free Analog Output .....	41
VAV Inputs.....	43
Inputs.....	44
Custom Sensors .....	53
Temperature Setpoints.....	56
Cooling Setpoints .....	57
Heating Setpoints .....	57
Wall Module Setpoints Configuration.....	57
DLC and Setpoint Recovery.....	57
SetPoint Ramp .....	58
OAT Ramp.....	58
Occupancy Setpoint Limits .....	58
Space Temp Alarm .....	59
Flow Setpoints .....	60
Use Special SI Units .....	61
Setpoints .....	61
Duct Area.....	61
CO2 Settings.....	61
Others.....	61
Control Parameters.....	63
Flow Control .....	64
Other Parameters .....	64
Schedule.....	65
Schedule .....	66

Holiday.....	69
PID.....	71
PID Settings for Cooling.....	72
PID Settings for Heating.....	72
Accessories Loops.....	73
Output.....	74
Inputs.....	75
Setpoint.....	81
Control Parameters.....	82
Custom Wiring.....	86
<b>OFFLINE POINT DISCOVERY.....</b>	<b>88</b>
<b>ONLINE OPERATIONS.....</b>	<b>89</b>
Download.....	89
Upload.....	89
Write Device Instance.....	89
Flow Balancing View.....	89
Sensor Calibration.....	90
Manual Mode/Diagnostics.....	91
Alarms.....	92
Monitor.....	93
Time Sync.....	94

## List of Tables

Table 1: Main Output Types.....	28
Table 2: Floating Control Parameters.....	34
Table 3: Inputs .....	44
Table 4: Custom Sensors.....	53
Table 5: Heating PID Parameters.....	72

## List of Figures

Figure 1: Typical CVB4024NS-VAV1/U box control application .....	8
Figure 2: Typical CVB4022AS-VAV1/U box control application .....	9
Figure 3: Installing WEBStation-N4™ .....	11
Figure 4: Installing WEBStation-N4™ (selecting installation location) .....	11
Figure 5: Installing Platform Daemon .....	12
Figure 6: WEBStation-N4™ – Getting started .....	13
Figure 7: Open Platform .....	15
Figure 8: Connect Platform .....	15
Figure 9: Authentication during Connecting Platform .....	15
Figure 10: Identity Verification during Connecting to Platform .....	15
Figure 11: Adding New Station .....	16
Figure 12: New station Wizard Window .....	16
Figure 13: Entering Admin Password for new station .....	16
Figure 14: Location of New Station (Stryker_BACnet_VAV) .....	17
Figure 15: Application Director .....	17
Figure 16: Selecting the Station to Start .....	18
Figure 17: Starting the Station .....	18
Figure 18: Started Station .....	18
Figure 19: Newly added station .....	18
Figure 20: Adding BACnet Network .....	19
Figure 21: Selecting BACnet Network to add .....	19
Figure 22: Adding specification to add BACnet Network .....	20
Figure 23: Newly added BACnet Network .....	20
Figure 24: Adding Palette .....	21
Figure 25: Opening Palette .....	21
Figure 26: Adding 'honeywellASC' to BACnet network .....	21
Figure 27: AscBACnetVAV in Palette TAB .....	21
Figure 28: Drag and drop AscBACnet VAV on BacnetNetwork .....	21
Figure 29: Naming controller .....	22
Figure 30: Location of controller .....	22
Figure 31: Loading VAV Configuration Wizard .....	22
Figure 32: Opening VAV Configuration Wizard Screen .....	22
Figure 33: Field description for VAV Configuration Wizard Screen .....	23
Figure 34: Configuration Screen .....	24
Figure 35: General Settings .....	24
Figure 36: Controller Type .....	25
Figure 37: Pressure Type .....	25
Figure 38: Box Type .....	25
Figure 39: Flow Type .....	25
Figure 40: Wall Module Type .....	25
Figure 41: Daylight Saving Settings .....	26
Figure 42: VAV Outputs window .....	27
Figure 43: Output Parameters of Damper Motor .....	31
Figure 44: Selecting Analog Control Parameters .....	31
Figure 45: Selecting PWM Control Parameters .....	32
Figure 46: Selecting Floating Control Parameters .....	32
Figure 47: Configuring Floating Control Parameters .....	33
Figure 48: Reheat Analog, PWM and Floating Controls .....	35
Figure 49: Selecting Analog Control Parameters .....	35

Figure 50: Selecting PWM Control Parameters ..... 35

Figure 51: Selecting Float Reheat Floating Control Parameters ..... 36

Figure 52: Peripheral Heating Type ..... 37

Figure 53: Selecting Peripheral Analog Reheat Control Parameters ..... 37

Figure 54: Selecting PWM Control Parameters ..... 37

Figure 55: Floating Peripheral Heat ..... 38

Figure 56: Fan Type ..... 39

Figure 57: Parallel Speed Control – Analog Control Parameters ..... 39

Figure 58: PWM Control Parameters ..... 39

Figure 59: Floating Control Parameters for Parallel Speed Control ..... 40

Figure 60: Free Analog Output ..... 41

Figure 61: Selecting Free Analog Output – Analog Control Parameters ..... 42

Figure 62: PWM Control Parameters ..... 42

Figure 63: Free Float Output ..... 42

Figure 64: VAV Inputs ..... 43

Figure 65: Space Temperature Setpoint ..... 51

Figure 66: Zio Wall Module ..... 51

Figure 67: Engineering Units ..... 52

Figure 68: Occupancy sensor ..... 52

Figure 69: Occupancy Sensor Operation ..... 52

Figure 70: Custom Sensors ..... 53

Figure 71: Custom Sensors Points ..... 55

Figure 72: Temperature Setpoints ..... 56

Figure 73: Flow Setpoints ..... 60

Figure 74: Control Parameters ..... 63

Figure 75: Schedule ..... 65

Figure 76: local Schedule type ..... 66

Figure 77: Schedule Type: Default Occupied ..... 66

Figure 78: Schedule Type: Default Unoccupied ..... 67

Figure 79: Scheduling an Event ..... 67

Figure 80: Custom Schedule ..... 68

Figure 81: Override Button Behavior ..... 68

Figure 82: Holiday ..... 69

Figure 83: Holiday Type ..... 69

Figure 84: Holiday Type ..... 70

Figure 85: Holiday List ..... 70

Figure 86: PID Settings ..... 71

Figure 87: PID Settings for Cooling ..... 72

Figure 88: PID Settings for Cooling ..... 72

Figure 89: Accessories Loops ..... 73

Figure 90: Output for Accessories Loop ..... 74

Figure 91: Modulating Output ..... 74

Figure 92: Auxiliary Output ..... 74

Figure 93: Output parameters for Staged Output ..... 75

Figure 94: Staged control action for Staged output ..... 75

Figure 95: Inputs for Accessories Loop ..... 75

Figure 96: Inputs for Main Sensor ..... 77

Figure 97: Inputs for Set point ..... 78

Figure 98: Inputs for Loop Disable ..... 78

Figure 99: Occupancy Status Setpoints ..... 79

Figure 100: Inputs for Occupancy Status ..... 79

Figure 101: Reset Sensor Setpoint ..... 80

Figure 102: Inputs for Reset Sensor .....	80
Figure 103: Setpoints .....	81
Figure 104: Setpoints for different occupancy modes .....	81
Figure 105: Setpoint Reset .....	82
Figure 106: Inputs for Reset Sensor .....	82
Figure 107: Main Control Parameters .....	83
Figure 108: PID Action .....	83
Figure 109: Auxiliary Output .....	84
Figure 110: Staged Outputs .....	85
Figure 111: Auxiliary and Staged Outputs .....	85
Figure 112: Input/output Terminal Assignments on VAV Controller .....	86
Figure 113: Overlay Diagram for Stryker VAV .....	87
Figure 114: Wiring Diagram for Stryker VAV .....	87
Figure 115: Offline Point Discovery .....	88
Figure 116: Selecting 'Download' .....	89
Figure 117: Selecting 'Upload' .....	89
Figure 118: Write Device Instance .....	89
Figure 119: Online Operations from VAV Configuration View .....	89
Figure 120: Sensor Calibration .....	90
Figure 121: Manual Mode/Diagnostics .....	91
Figure 122: Viewing Alarms .....	92
Figure 123: Monitoring the system operation .....	93
Figure 124: Set Time .....	94



## INTRODUCTION

Stryker VAV Controller is a pre-programmed configurable controller. It can be configured using 'VAV Configuration Wizard'. This configuration wizard is developed under WEBStation-N4 software tool.

### Stryker™ BACnet VAV Controller

The Honeywell Stryker controller is a configurable controller. It supports two applications,

1. **Without actuator**
2. **With actuator**

User can select any one of the applications and configure the controller accordingly.

Each application has various configurable settings, which provide multiple options and flexibility to user. For such settings, network variables are provided in the BACnet VAV controller.

Configuration of the BACnet VAV controller involves selection of the appropriate settings from available options as per the requirement.

These controllers are configurable using the Niagara Framework® software.

### WEBStation-N4™

The WEBStation-N4™, powered by the Niagara N4 Framework® is a flexible network server for all connected WEBS- N4 controllers.

WEBStation- N4™ creates a powerful network environment with comprehensive database management, alarm management and messaging services.

WEBStation- N4™ hosts an application called 'BACnet VAV Configuration Wizard', which provides an engineering environment for configuration of BACnet VAV controller.

#### Features

- Provisioning of the multi-controller systems (tools for updating and installation of software modules).
- Central database storage for attached controllers.
- Archive destination/repository for log and alarm data.
- Central server of graphics and aggregated data (single point of access to the system – one IP address).

- Platform for optional enterprise applications.

WEBStation- N4™ acts as a network server or a 'Supervisor' for all connected WEBS-N4™ Controllers. It creates a network environment for the management of these controllers, alarms and messaging services.

### BACnet VAV Configuration Wizard

It is a special application developed in the WEBStation-N4 to configure the BACnet VAV controller. All configurable network variables of the VAV controller are accessible through this application for configuration.

BACnet VAV Configuration Wizard provides a mean to select settings for all components of the BACnet VAV system, control strategy and parameters as per the application requirement.

Following operations can be performed using WEBStation-N4 and Configuration Wizard:

1. Adding a Stryker VAV controller on the BACnet network.
2. Configure and set the parameters as per the application requirements.
3. Create a database by discovering the objects and adding them on Niagara level, which can be used for global programming if required. These points can also be bound to graphics if graphics is generated for the application.
4. Download and upload the configuration into the selected BACnet VAV. (Online Operation).  
Monitoring the points and operation of the BACnet VAV. (Online)
5. Set the time and date (Online Operation)
6. Calibration of sensors (Online Operation)
7. Manual Mode/Diagnostics: In this operation, device can be put in manual mode to override the outputs. Mainly it is useful during commissioning for point to point testing.(Online Operation)
8. Alarms: Alarms can be monitored using 'Alarms' menu (Online Operation)
9. Monitor: In this operation, user can view and write the values of inputs for functional testing of the system during commissioning. PID loop operations can be tested by writing values in the inputs.

## Control Application

VAV systems in commercial buildings typically incorporate a central air handler that delivers a modulated volume of air at a preconditioned temperature to multiple zones. Each zone is served by a VAV terminal box unit. Each box incorporates an airflow pickup assembly and motorized damper with optional fan and/or reheat coil. The controller determines and regulates the airflow of conditioned air to the space.

The zone being served by the terminal box will use a TR2X Wall Module or a Zio (TR71/TR75 only) Digital Wall Module for space temperature determination and access to the BACnet MS/TP network for operators. Figure 1A shows a typical VAV box control application for the CVB4024NS-VAV1/U controller. Figure 1B shows a typical VAV box control application for the CVB4022AS-VAV1/U controller.

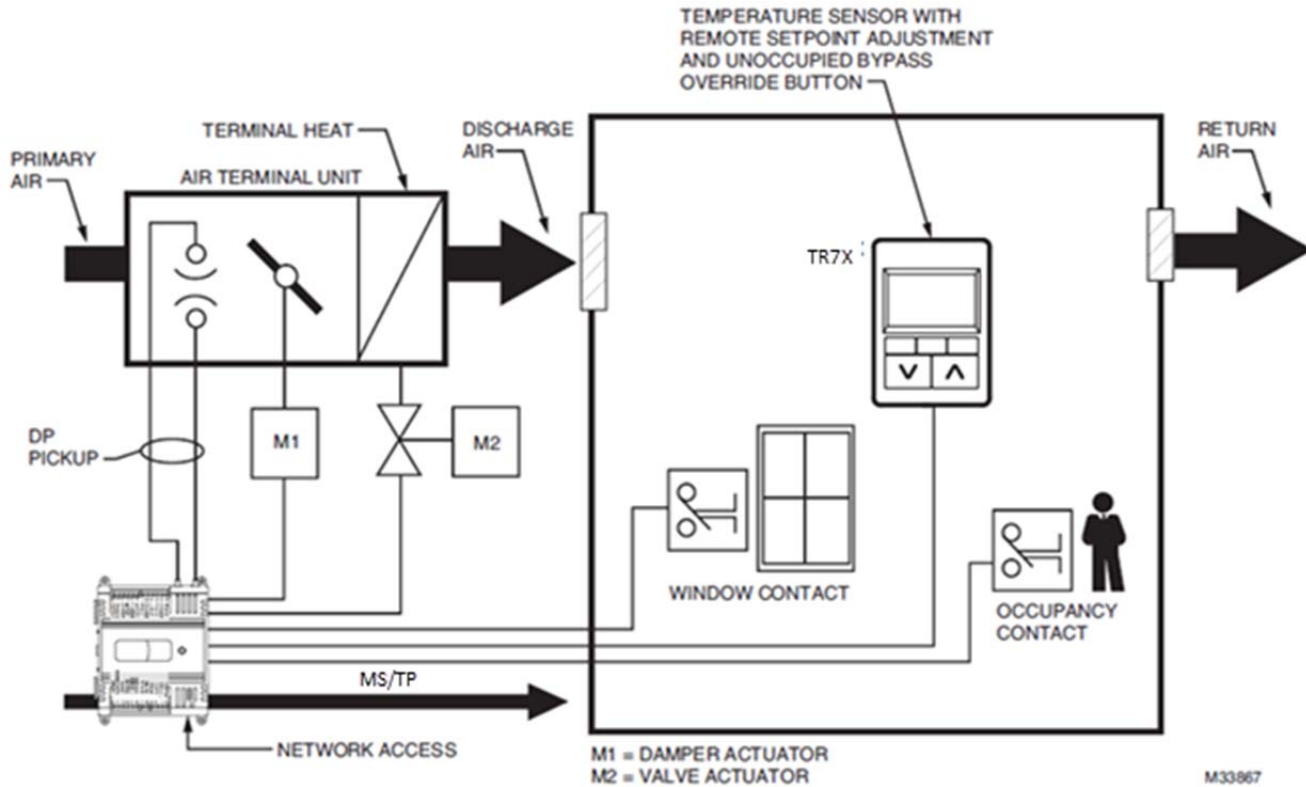


Figure 1: Typical CVB4024NS-VAV1/U box control application

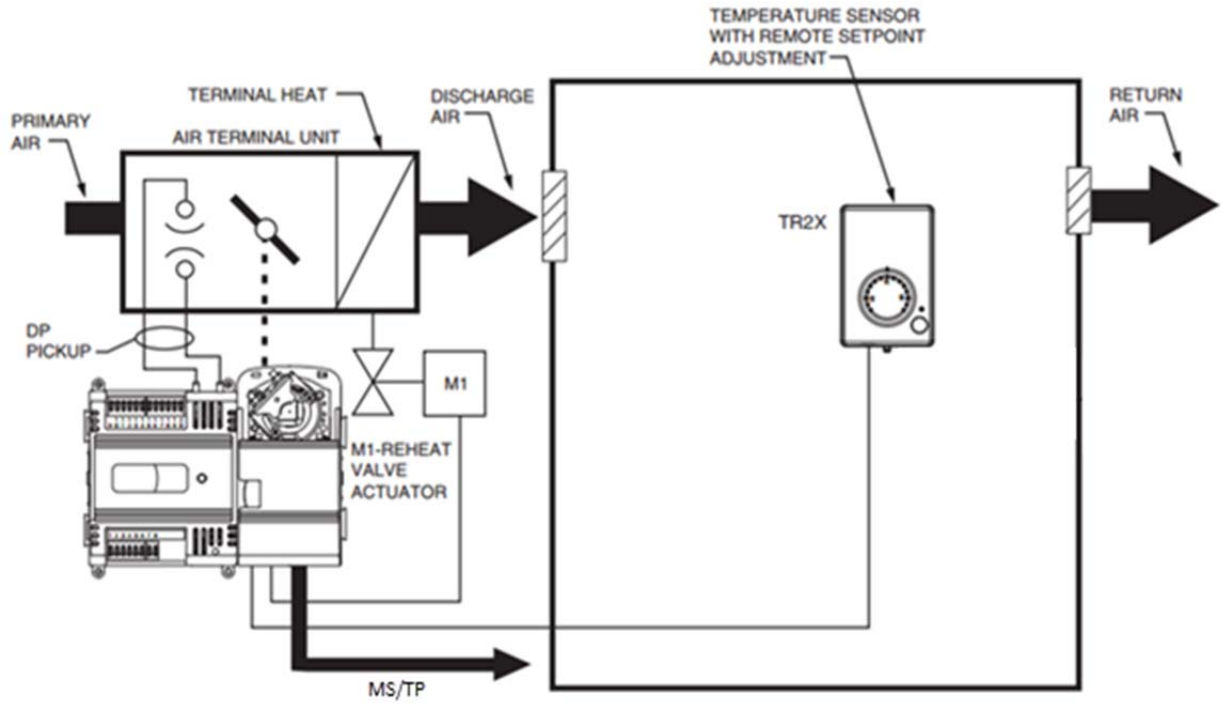


Figure 2: Typical CVB4022AS-VAV1/U box control application

## Control Provided

The CVB Controllers are primarily intended for pressure independent, single duct VAV box control. Pressure independent control specifies that the individual zone terminal unit have a means for maintaining a consistent volume of air into the zone regardless of the input static pressure. The controller modulates the airflow into the zone to satisfy the Zone Temperature Setpoint. Minimum Airflows are maintained except during emergency strategy periods or during building Unoccupied periods if using physical position stops, a minimum / maximum airflow is always maintained. Pressure dependent control specifies that the damper position is controlled by space temperature only and not by a measurement of airflow volume. The amount of air delivered to the zone at any given damper position is dependent on the static pressure in the supply air duct (physical position stops, range stop pins, are used to keep the damper at a fixed position). Additional outputs are available for control of heating systems such as reheat coils for Heat mode or Morning warmup mode operation. The heating equipment can be staged resistive heating, staged 2-position (solenoid) valve, or modulated steam or hot water valve.

## VAV Configuration Requirement

VAV controller can be configured using two methods:

1. With WEBStation-N4 Software Tool
2. Through TR75 Module

### With WEBStation-N4 Software Tool

In the WEBStation-N4™ software tool, VAV Configuration Wizard application is integrated for VAV controller configuration.

#### 1. Configuration through PC

VAV controller can be accessed with the personnel computer with WEBStation-N4 software tool installed on it. A VAV controller can be accessed for configuring, uploading and downloading operations through BACnet adaptor, which connects a PC through an Ethernet cable.

#### 2. Configuration through WEBs Controller

If the VAV controller is on the BACnet network of WEBs controller, it can be accessed through WEBs controller using PC with WEBStation-N4 tool installed on it.

When WEBs controller is already commissioned, then it can be accessed through IP address with personnel computer without WEBStation-N4 software tool installed on it. All required operations

on the Stryker VAV controller can be performed by accessing WEBs controller.

### Through TR75 Module

Configurable network parameters are also accessible through TR75 wall module. From the wall module, VAV application can be configured as per requirement. Access to the configurable parameters is password protected with default password 0000. For details, refer to 'Stryker VAV Zio Configuration Guide.'

## Products Covered

This Configuration Guide describes how to configure Stryker VAV controller via VAV Configuration Wizard. Stryker VAV Controllers, related accessories and required software tools and applications are as follows:

- Stryker VAV Controller
- WEBStation-N4 Software Tool
- BACnet to MS/TP adaptor
- WEBs Controller

## Organization of the manual

This manual is divided into two basic parts: introduction and configuration.

The Introduction provides information for Stryker BACnet configurable VAV controller WEBStation-N4™ Software tool, VAV Configuration Wizard application, control application, control provided, product covered, and abbreviations.

Configuration steps provide information for engineering of Stryker BACnet configurable VAV controller by VAV Configuration Wizard using its various settings options.

# CONFIGURATION OF VAV CONTROLLER

## Installation

Before proceeding to the VAV Configuration wizard, WEBStation-N4™ needs to be installed as it hosts configuration wizard.

### Installation of WEBStation-N4™ Tool

WEBStation-N4™ software is distributed via the web or a DVD, and has the following minimum hardware requirements:

**Processor:** Intel Pentium® IV, 2 GHz or higher

**Operating System:**

32-bit: Microsoft Windows XP Professional, Windows 2003 or 2008 Server (if Microsoft IIS is disabled), Vista Business or Windows 7

64-bit: Windows XP Professional, Windows 7

**Browser:** Microsoft IE versions 7, 8, 9, Google Chrome version 15, and Mozilla Firefox version 8, 10, 12

**Memory:** 1 GB minimum, 2 GB or more recommended for large systems, 8 GB or more recommended for the windows 64-bit version

**Hard Drive:** 1 GB minimum, 5 GB for applications that need more archiving capacity

**Display:** Video card and monitor capable of displaying 1024 x 768 pixel resolution or greater

**Network Support:** Ethernet adapter (10/100 Mb with RJ-45 connector)

**Modem:** 56 KB minimum, full time high speed ISP connection 1111 recommended for remote site access (i.e. T1, ADSL, cable modem).

These requirements may be slightly different for different versions of WEBStation-N4™ as support for newer operating systems is added. For the latest product data, visit <http://customer.honeywell.com>

After selecting the setup for installation, proceed by clicking 'Next' to accept the license agreement.

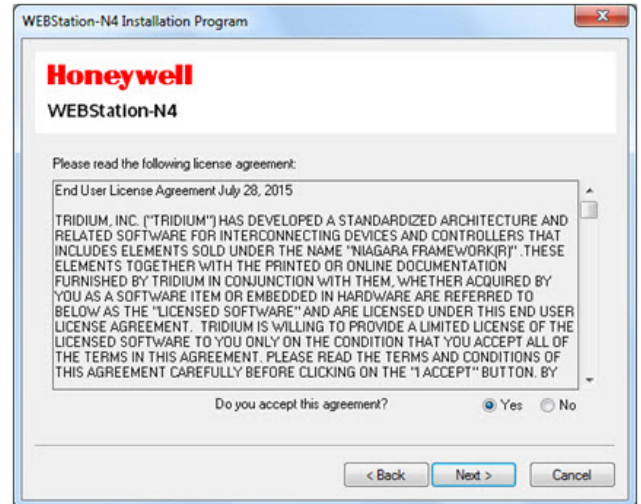


Figure 3: Installing WEBStation-N4™

Select the installation location, (It will create a path in 'C' drive under 'Honeywell' folder by default)

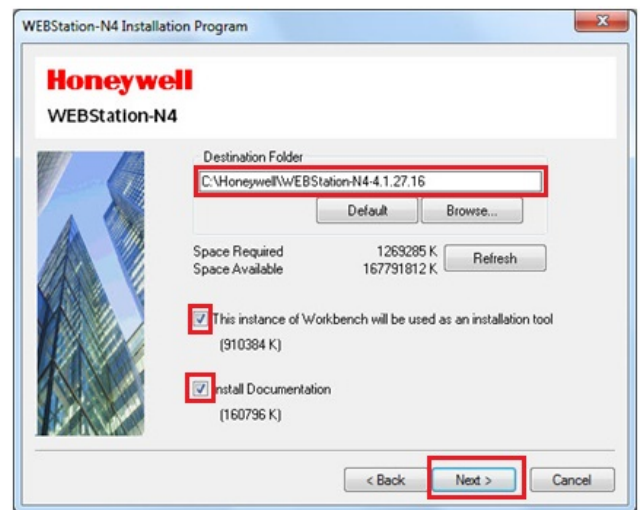


Figure 4: Installing WEBStation-N4™ (selecting installation location)

Click 'Next' button to proceed after selecting appropriate options.

Wait until the installation gets finished.

## Installation of Stryker BACnet VAV Wizard

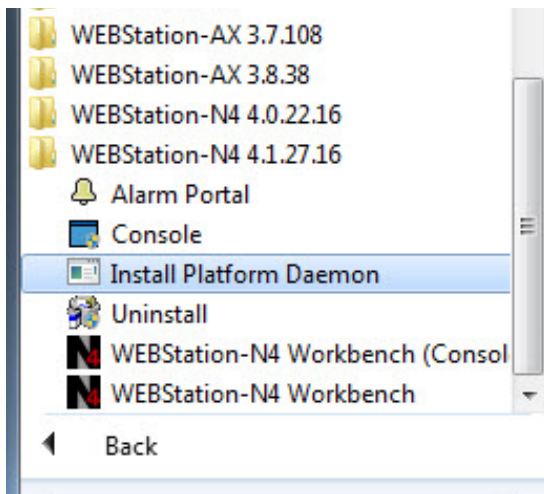
### Niagara WEBStation-N4™ version 4.1.27.16

For this version of WEBStation-N4™, there is no need to install Configuration wizard separately. It is installed by default during installation of WEBStation-N4.1.27.16.


## Getting Started

BACnet VAV Wizard is a user interface where a user can set; adjust various types of parameters for VAV.



To start working with configuration wizard, go to 'Start' menu, select 'All Programs', navigate to 'WEBStation-N4 4.1.27.16' folder and click on it. Click 'Install Platform Daemon' as shown in [Figure 5](#).



**Figure 5: Installing Platform Daemon**

	<b>Note:</b>
<ul style="list-style-type: none"> <li>• <i>If more than one version of WEBStation-N4 are installed on the same PC, It is mandatory to install Platform Daemon when switching from one version to other. It is not required to install Platform Daemon if the same version of WEBStation-N4 needs to open consecutively.</i></li> <li>• <i>If only single version of WEBStation-N4 is installed, then it may not be required to install Platform Daemon every time while opening WEBStation-N4.</i></li> </ul>	

After installing Platform Daemon completely, go to 'Start' menu again and select 'All Programs' navigate to 'WEBStation-N4 4.1.27.16' folder and click on it. Click 'WEBStation-N4 Workbench', it will open 'WEBStation-N4' window. Refer to [Figure 6](#).

	<b>Note:</b>
	
<p><i>'WEBStation-N4' can also be open by clicking an icon named 'WEBStation' on the desktop</i></p>	

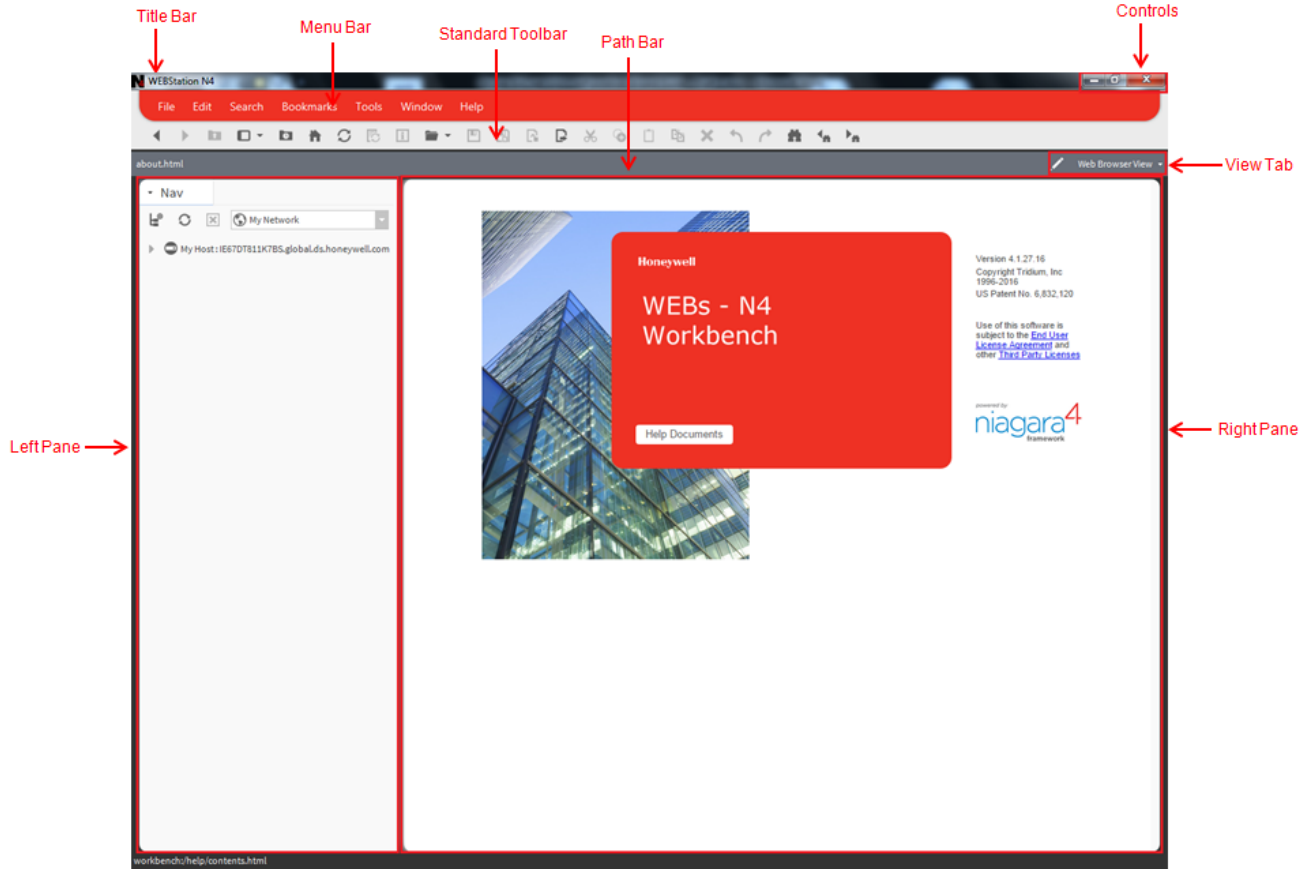


Figure 6: WEBStation-N4™ – Getting started.

The field description for Figure 6 is as follows:

1. Title Bar:



Top of the WEBStation interface is Title bar. It displays title of the screen.

2. Controls



An application can be minimized, maximized and closed with these controls.

3. Menu Bar



It displays heading for drop-down menus.

According to function, commands are group in to the menu tabs. These are File, Edit, Search, Bookmarks, Tools, Window, and Help.

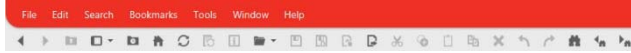
- I. **File:** User can open, close and save the file, directory, query, new tab, new window using File tab.
- II. **Edit:** Cut, copy, paste, duplicate delete options are available.
- III. **Search:** A file can be searched and navigate from one file to other file.
- IV. **Bookmarks:** user can add or manage bookmarks.
- V. **Tools:** user can maintain certificates, license, migration and credential details.
- VI. **Window:** User can add/ hide Side Bar, Console window, check Active Plug-in.
- VII. **Help:** User can get assist by clicking F1 or help tab.

#### 4. Standard Tool Bar



Various functions can be accessed using this tool bar. It provides a quick shortcut to frequently used functions.

#### 5. Ribbon



It includes menu bar and standard toolbar.

#### 6. Path Bar



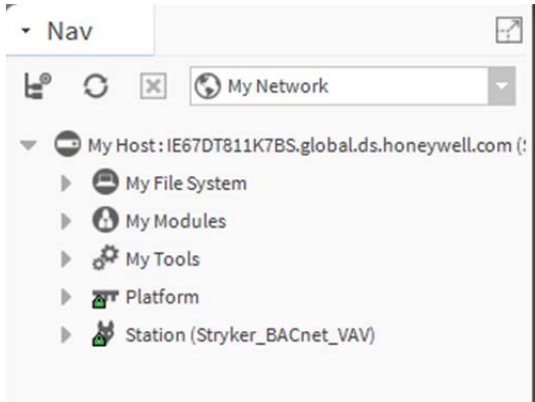
A path of a particular function can be tracked using this.

#### 7. View Tab



It is used to switch between various views, such as, Html View, Text File Editor, Text File Viewer, and Hex File Editor.

#### 8. Left pane



Nav tree details can be viewed over here.

#### 9. Right Pane



Details about Version, License and Certificate are found over here.



## How to configure VAV Configuration Wizard User interface

'VAV Configuration Wizard's user interface window is obtained with the help of following steps

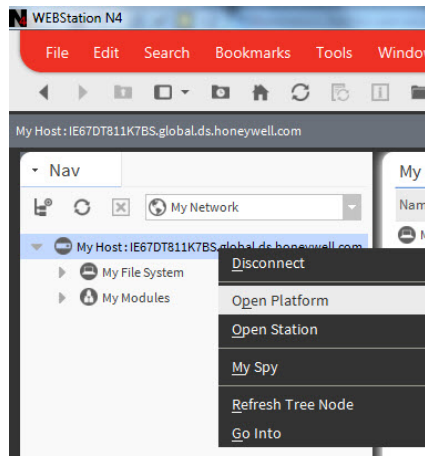
1. Connecting to platform
2. Adding new station
3. Starting/Running new station
4. Adding Bacnet Network
5. Adding VAV Controller to the Bacnet Network

### 1. Connecting to Platform

To perform various operations, it is necessary to connect to the Platform initially.

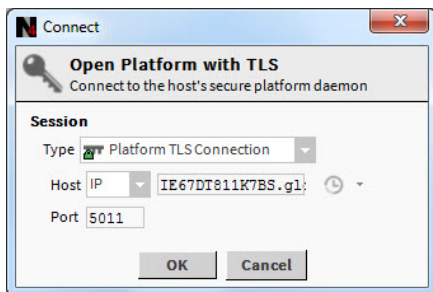
To connect Platform, follow the process:

Navigate to 'My Host: ...' in the Left pane, by right clicking on it, select 'Open Platform'. Refer to [Figure 7](#).



**Figure 7: Open Platform**

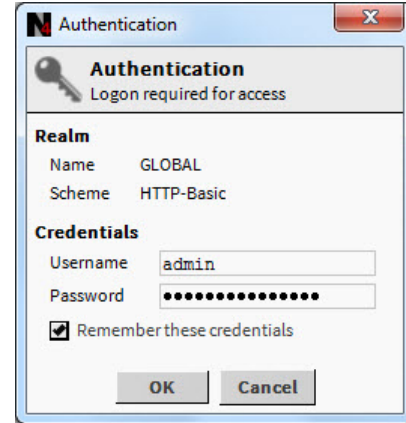
A window will pop up to connect to the Host's secure platform daemon. Click 'OK' to proceed.



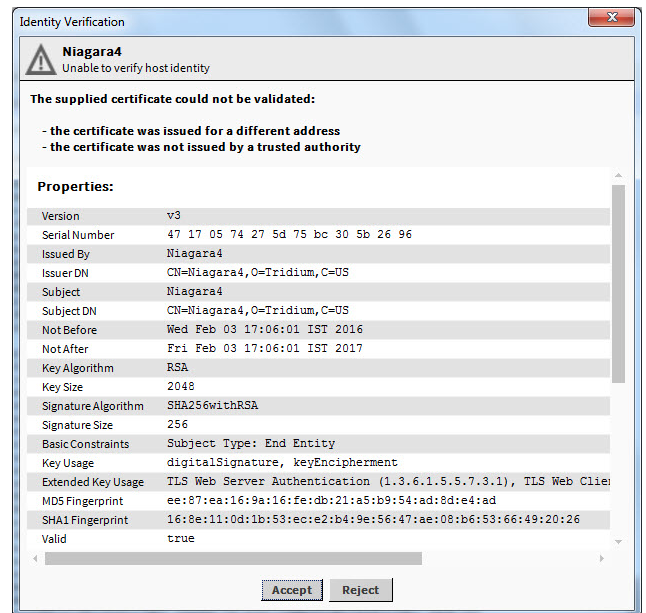
**Figure 8: Connect Platform**

An Identity Verification window may pop up during the first time configuration. Click 'Accept' to verify. (Refer to [Figure 10](#)).

Enter Username and Password and click 'OK'



**Figure 9: Authentication during Connecting Platform**



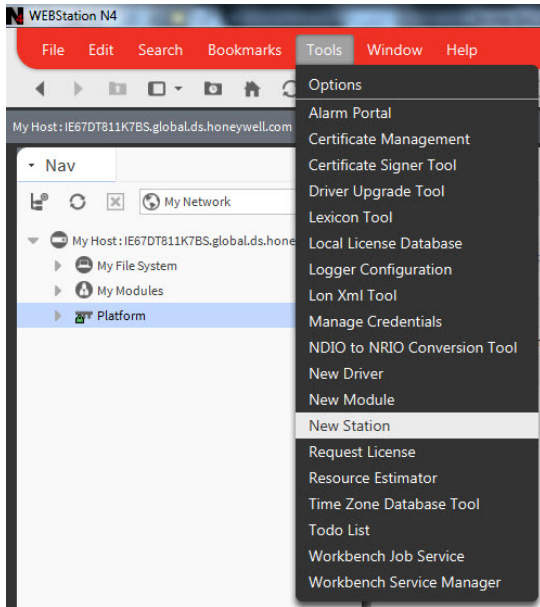
**Figure 10: Identity Verification during Connecting to Platform**

### 2. Adding New Station

The next stage is to add a new station under platform. Different controllers can be added to the respective network assigned to the station.

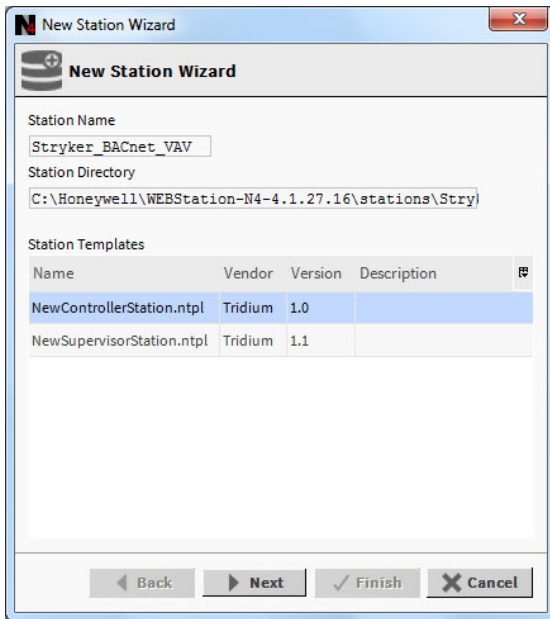
To add a new station:

- Navigate to the Platform by click sign of Host in the left pane.
- Click 'Tools' tab on menu bar.
- Navigate to 'New station' and click on it.



**Figure 11: Adding New Station**

- After clicking 'New Station', it opens 'New Station Wizard' window. (Refer to [Figure 12](#))
- Enter name in Station Name field. For example, 'Stryker\_BACnet\_VAV' is added here. Station Directory displays a path by default.
- Click 'Next'



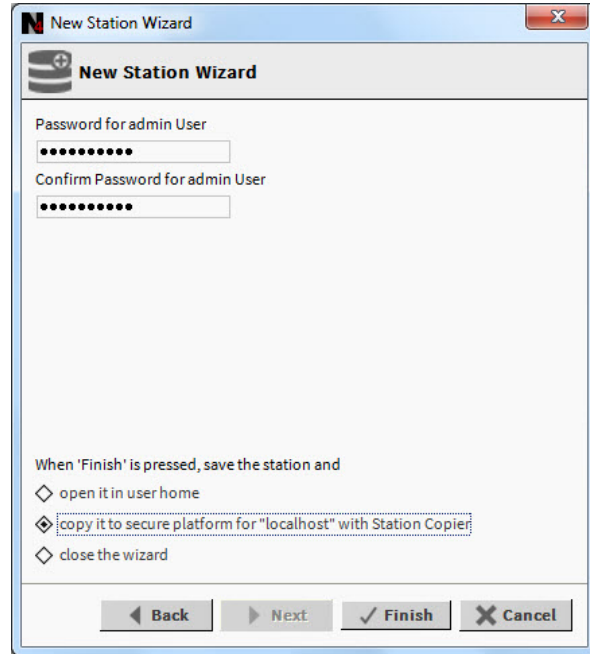
**Figure 12: New station Wizard Window**

- Enter 'Admin Password'. Enter the same password in 'Confirm Admin Password' field.

**Important:**

**Password must contain:**

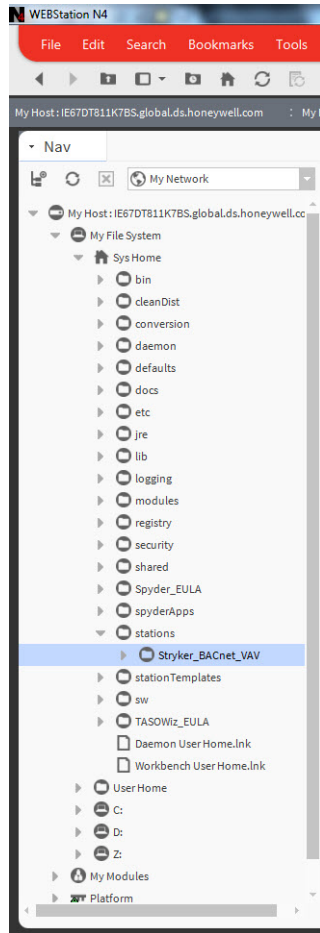
- at least 10 character(s)
- at least 1 digit(s)
- at least 1 lower case character(s)
- at least 1 upper case character(s)



**Figure 13: Entering Admin Password for new station**

- Click 'Finish' to complete action.

It creates a station at 'My Host > My File System> Sys Home > Stations > (created station)'. Refer to [Figure 14](#).



**Figure 14: Location of New Station (Stryker\_BACnet\_VAV)**

### 3. Starting new Station

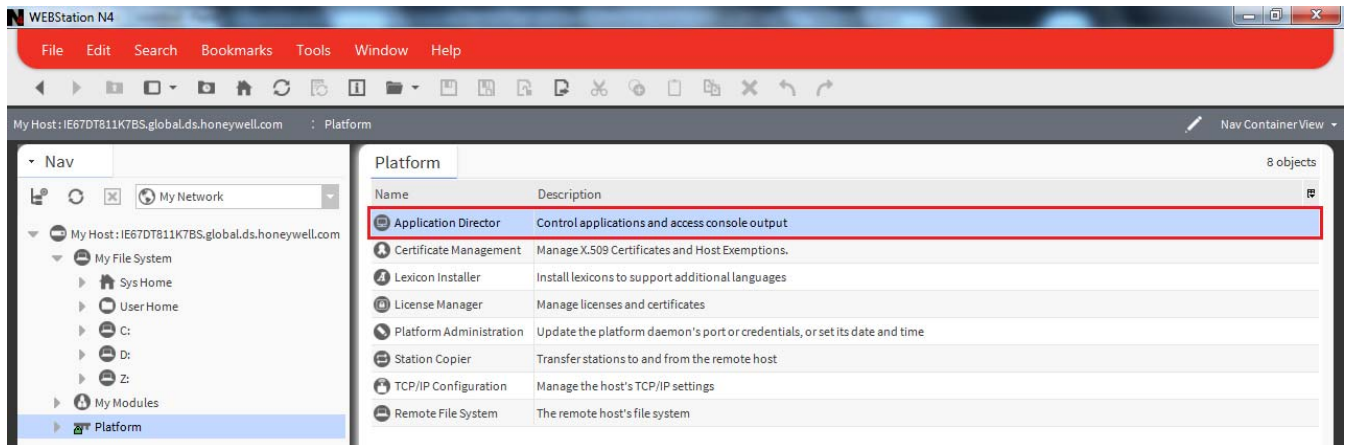
To start configuration of controller, it is necessary to start the station. Following is the process to start a newly added station:

Double click on 'Platform', it opens a screen as shown in [Figure 15](#).

Double click on 'Application Director' at the right pane. (Refer to [Figure 15](#)).

Select the newly created station ('Stryker\_BACnet\_VAV' in this case) by just clicking on it. Status for this station will be Idle at this stage.

Click 'Start' button as shown in [Figure 16](#). After clicking 'Start', the 'Status' of this station will change to 'Starting' as shown in [Figure 17](#).



**Figure 15: Application Director**

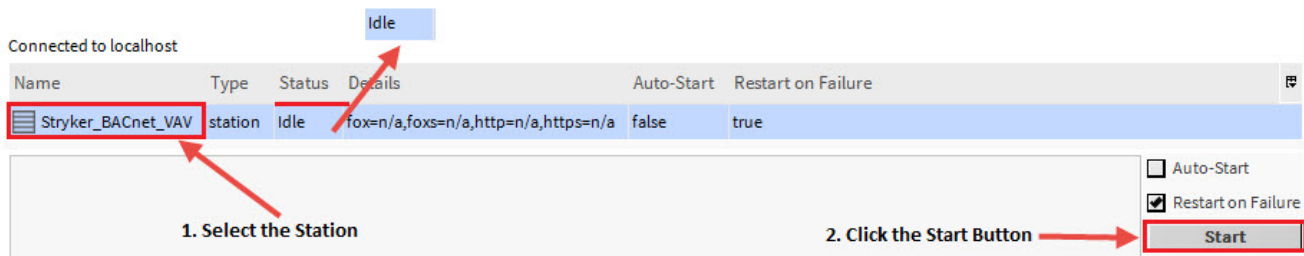


Figure 16: Selecting the Station to Start

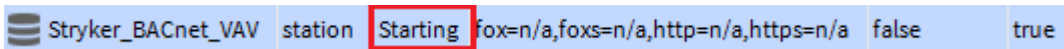


Figure 17: Starting the Station

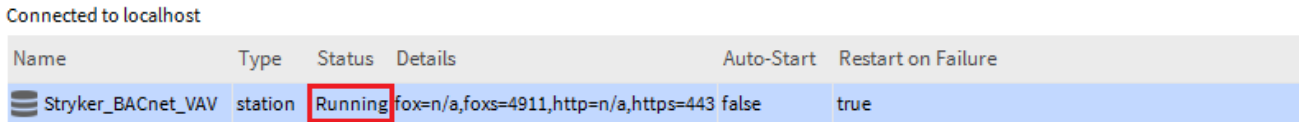


Figure 18: Started Station

Once the station is started, its status changes to 'Running' (Refer to Figure 18).

Double click on the running station, a 'verification window will pop up as shown in Figure 10. Click 'Accept' to proceed.

It opens an authentication window. Enter username and password. Click 'OK' to proceed.

	<b>Note:</b>
<p>Check 'Remember these credentials' box to remember the username and passwords so that it will not be required to enter it every time during opening the station.</p>	

Check newly added station as shown in Figure 19.

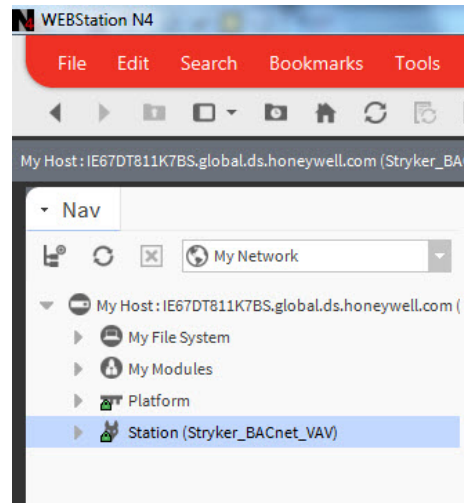


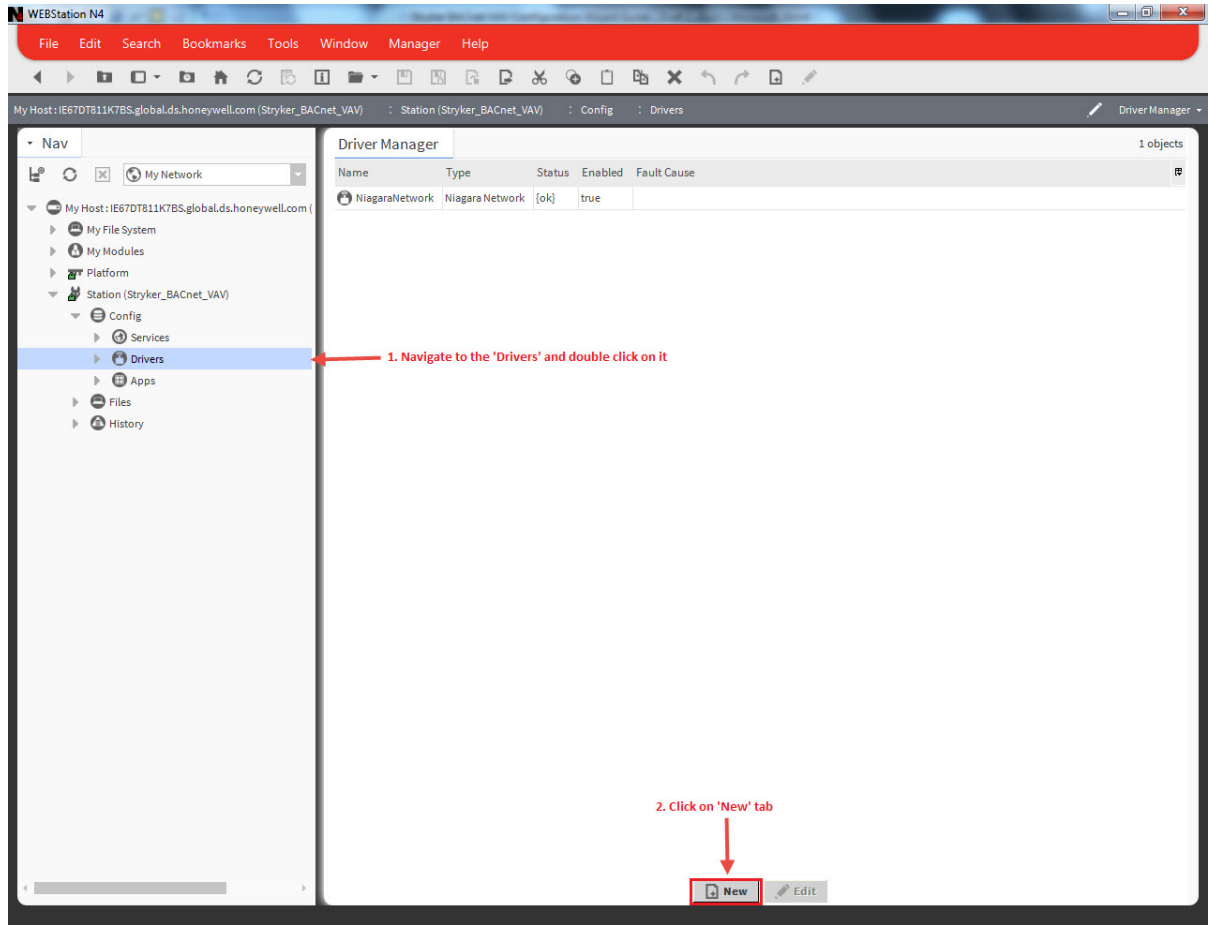
Figure 19: Newly added station

#### 4. Adding BACnet Network to Niagara Network

VAV controller works with BACnet network.

To add a BACnet Network, following is the process:

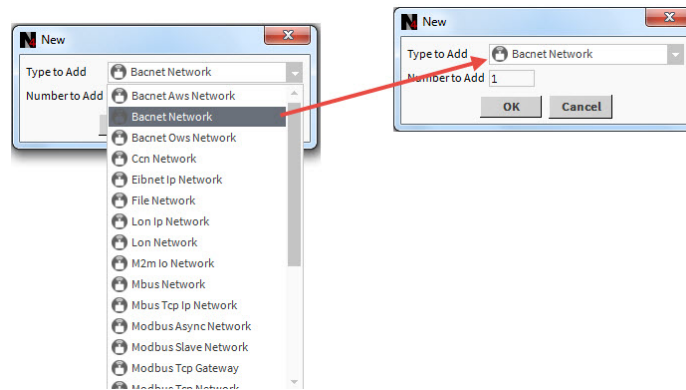
- Navigate to Drivers and double click on it.
- Click on 'New' tab Refer to [Figure 20](#).



**Figure 20: Adding BACnet Network**

- A window will pop out as shown in [Figure 21](#), asking 'Type to Add'.
- Select 'Bacnet Network' from the drop down list.

Required number of networks can be added in 'Number to Add' field. (In this guide since only one network is shown, Number is added as '1' )



**Figure 21: Selecting BACnet Network to add**

- Click 'OK' to proceed.
- Next, a new window will appear, showing 'Name', 'Type' and 'Enabled'(keep its value to 'True'). Refer to [Figure 22](#).
- Click 'OK'.

- A newly added 'Bacnet Network' can be seen under 'Driver manager' on the right pane highlighted in Amber color as shown in [Figure 23](#).  
(An amber colored background highlight appears, as BacnetNetwork is offline. Background will turn white when it is online.)

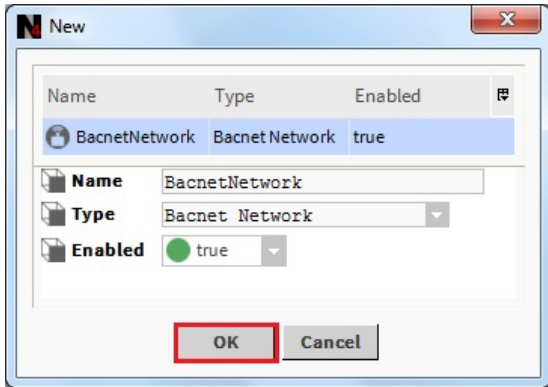


Figure 22: Adding specification to add BACnet Network

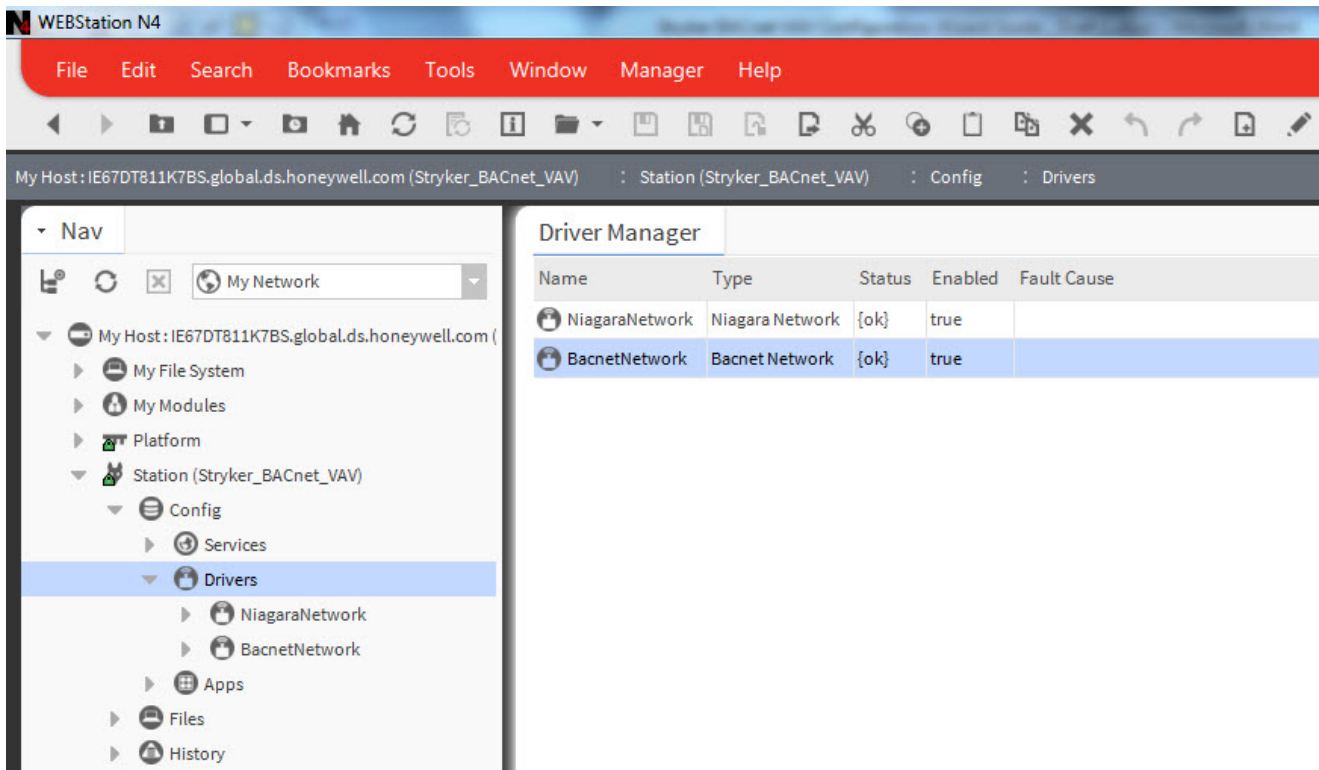
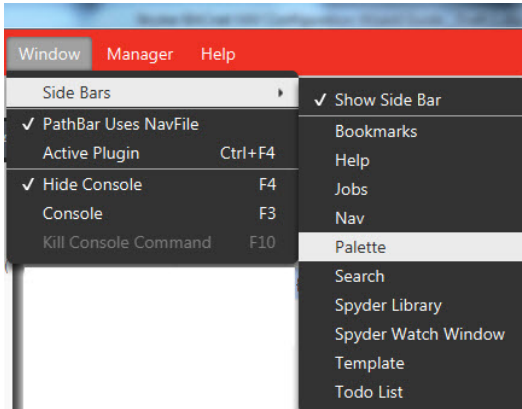


Figure 23: Newly added BACnet Network



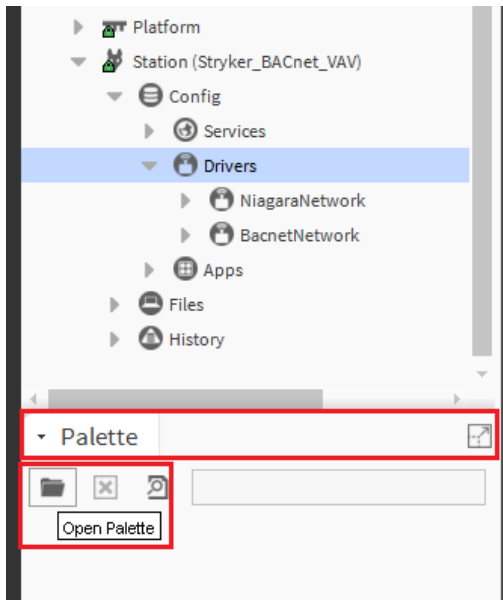
**5. Adding VAV Controller to the Bacnet Network**

- After adding a Bacnet Network to the Drivers, next step is to add a VAV controller to the BACnet Network.
- Click on 'Window' option in Menu bar; navigate to 'Palette' through sub menu of 'Side Bars'. (Refer to Figure 24).



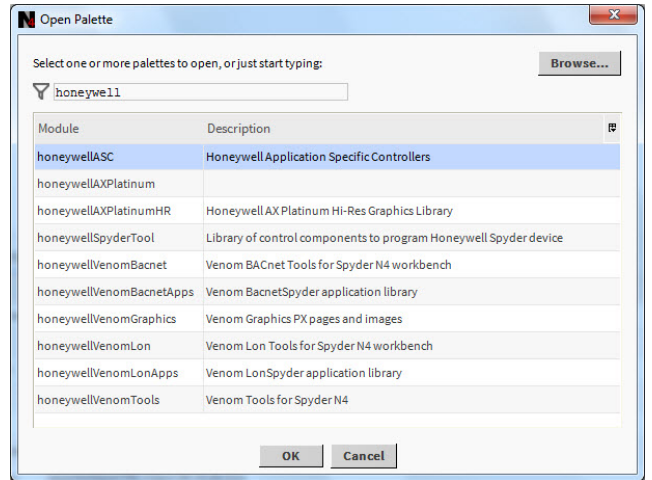
**Figure 24: Adding Palette**

- This will add a 'Palette' tab in the left pane. (Refer to Figure 25). Click 'Open Palette' option.



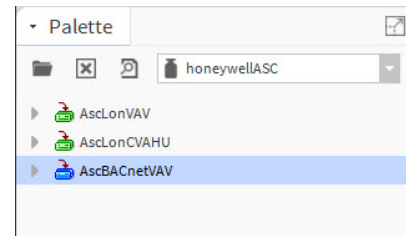
**Figure 25: Opening Palette**

- An 'Open Palette' window will open. Find a module named 'honeywellASC' as shown in Figure 26, Select it and click 'OK' button to add into the Palette.



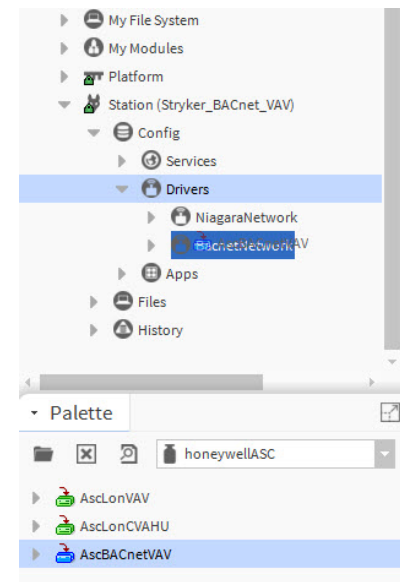
**Figure 26: Adding 'honeywellASC' to BACnet network**

- Adding 'honeywellASC' gets reflected in the 'Palette' tab as 'AscBACnetVAV' as seen in Figure 26.



**Figure 27: AscBACnetVAV in Palette TAB**

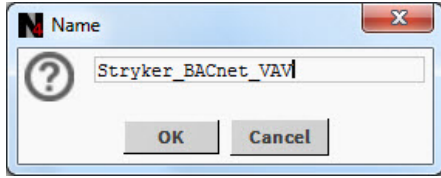
- Drag 'AscBACnetVAV' and Drop it on 'BacnetNetwork' added under created station. Refer to Figure 28.



**Figure 28: Drag and drop AscBACnet VAV on BacnetNetwork**

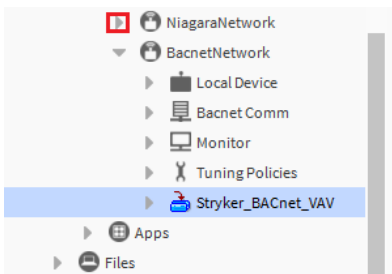
A window will pop up as 'AscBACnetVAV' is dropped on BacnetNetwork to name the controller. Enter the name accordingly.

In this guide, it is named as 'Stryker\_BACnet\_VAV' as shown in [Figure 29](#).



**Figure 29: Naming controller**

It can be seen by clicking  sign as shown in [Figure 30](#).



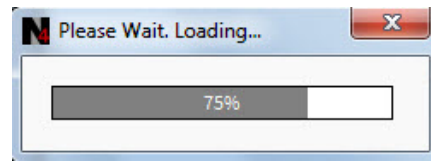
**Figure 30: Location of controller**

## VAV Configuration Wizard

Wizard is a utility within an application, which provides a systematic process for setting up the different parameters.

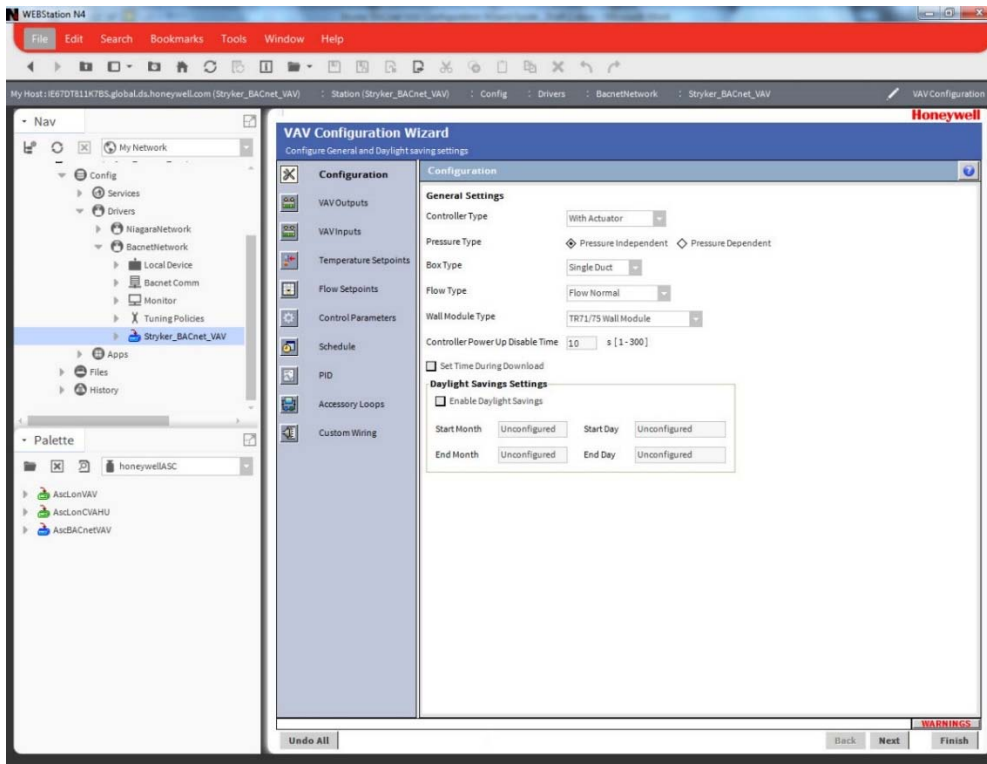
In this case, VAV Configuration Wizard is used to configure the VAV controller.

In order to start working with VAV wizard, navigate to BacnetNetwork (refer to [Figure 30](#)). Double click on added controller (here, 'Stryker\_BACnet\_VAV'). It will start loading wizard application.



**Figure 31: Loading VAV Configuration Wizard**

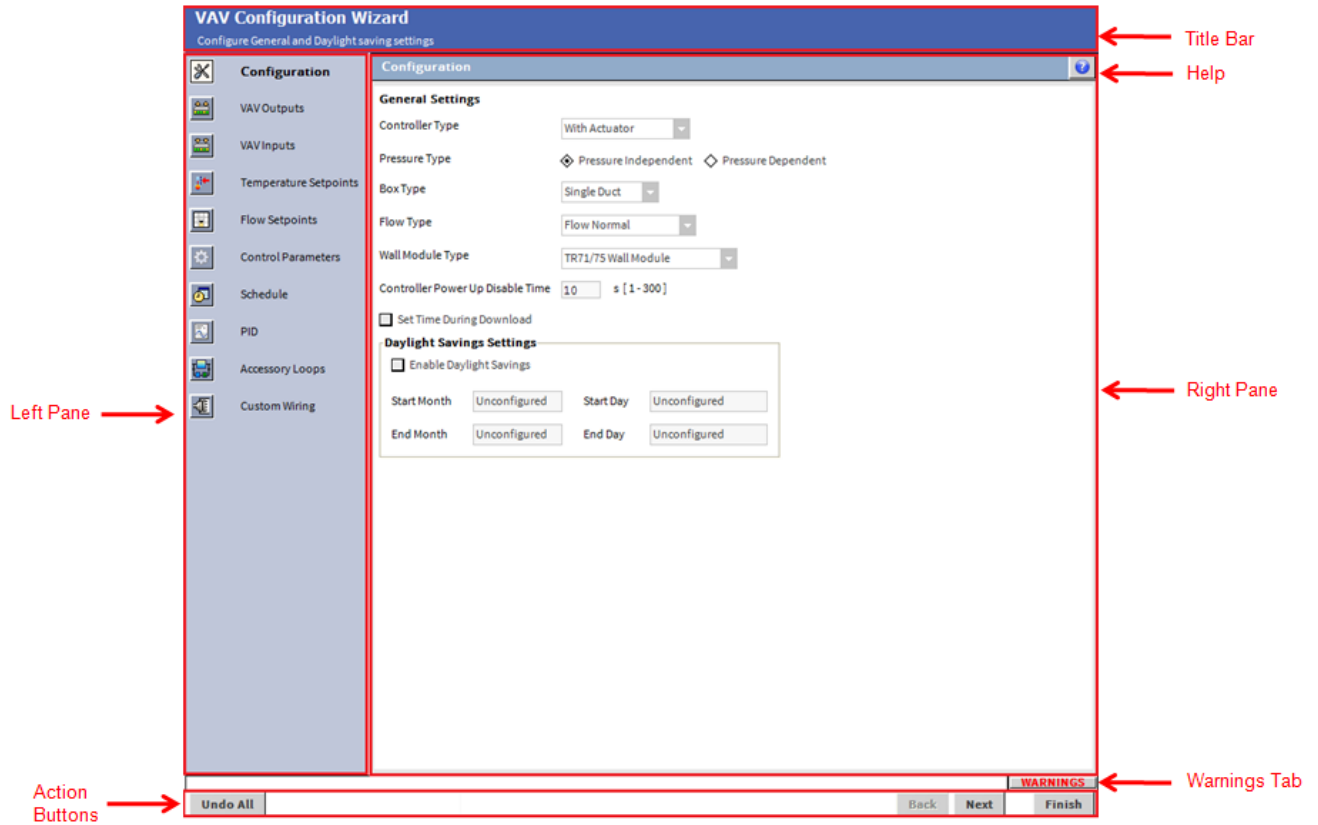
After complete loading, it opens VAV Configuration Wizard window as shown in [Figure 32](#).




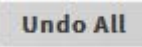


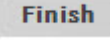
**Figure 32: Opening VAV Configuration Wizard Screen**




## Field description for VAV Configuration Wizard



**Figure 33: Field description for VAV Configuration Wizard Screen**

1. **Title Bar**  
It displays name as 'VAV Configuration Wizard' with name of selected parameter.
2. **Left Pane**  
It displays the list of setting buttons for various groups of configuration parameters.
3. **Right Pane**  
It displays Configuration settings as per selected group of parameters.
4. **Help**  
Press  for help if any related information is needed at any point.
5. **Warning Tab**  
It displays an event or a statement, which warns/gives cautions about an error or a situation.
6. **Action Buttons**  
It displays following buttons:
  -  It is used to reset action to its last saved value.
  -  It is used to go to the previous screen.
  -  It is used to go to next screen.
  -  It is used to complete or save an action.

# CONFIGURATION

Configuration  is a first parameter of a Configuration Wizard.

Configuration screen is a combination of three types of settings i.e. General Settings and Daylight Savings Settings.

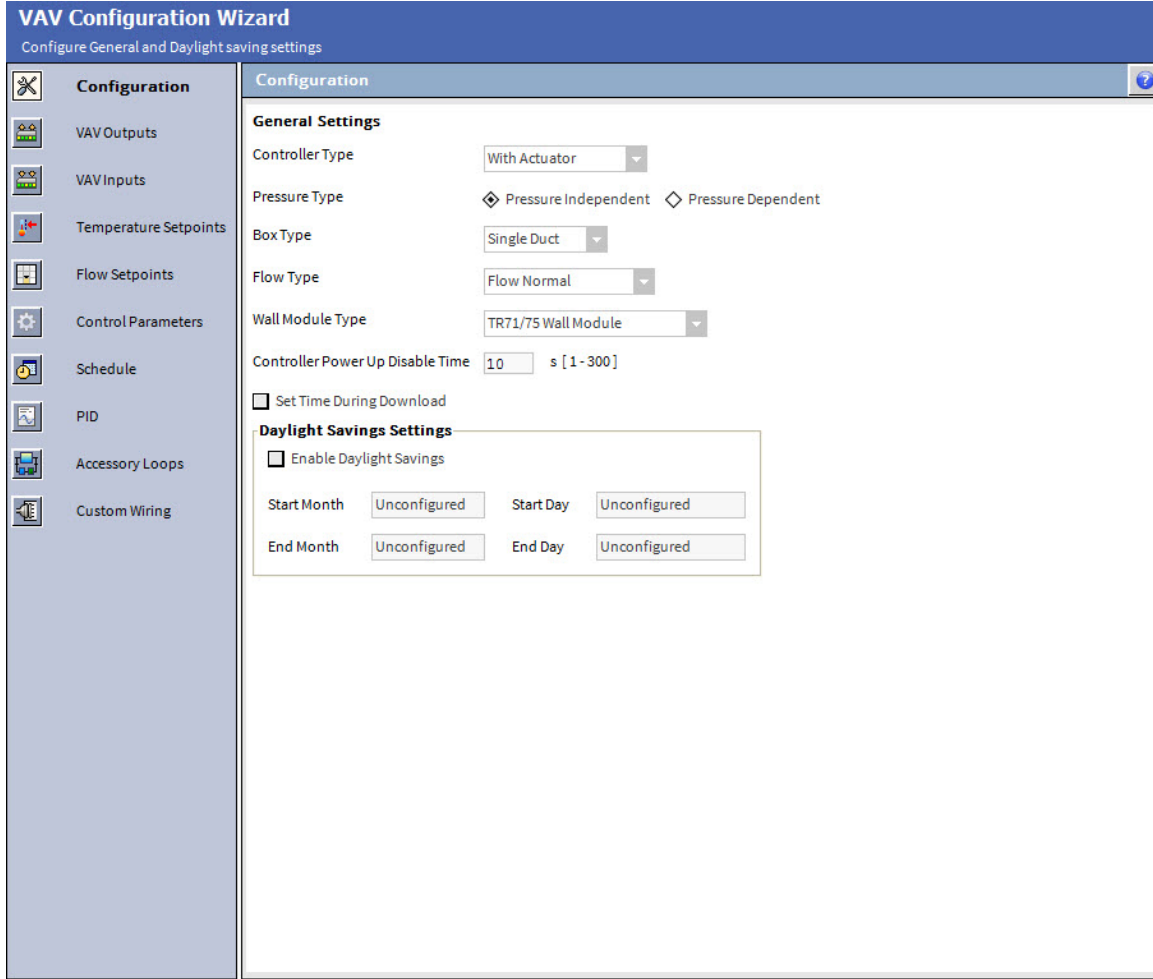


Figure 34: Configuration Screen

## General Settings

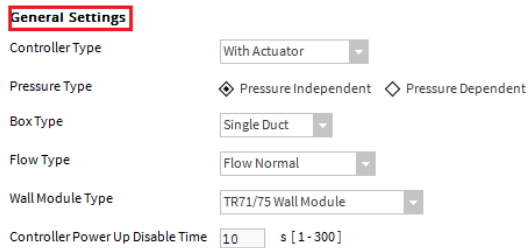


Figure 35: General Settings

### Controller Type

A controller type for an application can be selected as per the requirements. This is a fundamental setting, on which the other settings depend.



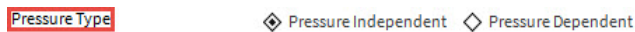
**Figure 36: Controller Type**

**Without Actuator:** Select this option if BACnet controller model is CVB4022NS-VAV1/U

**With Actuator:** Select this option if BACnet controller model is CVB4024AS- VAV1/U

**Pressure Type**

Displays the VAV Terminal Unit pressure control operation for this application. This selection defines how the controller will operate the VAV Terminal Units damper.



**Figure 37: Pressure Type**

**Pressure Independent:** Select this option if user wants to configure the controller to use airflow as the primary means of controlling the VAV Terminal Damper.

**Pressure Dependent:** Select this option if user wants to configure the controller to use space temperature as the primary means of controlling the VAV Terminal Damper.

**Box Type**

Box Type allows the selection to determine what control options are available for the VAV Terminal.



**Figure 38: Box Type**

**Single Duct:** Select this type if user wants a single primary air supply inlet and outlet connection with or without a primary flow sensor.

**Flow Type**

Depending upon the selection of the Pressure Type and Box Type selected, following control flow algorithm can be selected.



**Figure 39: Flow Type**

**Flow Normal:** The flow is controlled to satisfy the temperature control algorithm.

**Flow Tracking:** User can select this flow type only when the Pressure Type is set to pressure independent.

**Shared Wall Module:** This option can be selected when the temperature control loop is turned off and the flow is controlled by the wall module at another master node.

**Wall Module Type**

Displays the type of wall module to be used for this application. This selection determines the type of control and options that are available from the wall module. Valid selections for this field are:



**Figure 40: Wall Module Type**

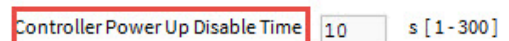
**None:** There is no physical wall module connection to this controller.

**Conventional Wall Module:** Select this when using the TR21, TR22 and TR23 series of wall modules.

**TR71/75 Wall Module:** These wall modules provide access to configuration parameters and schedule events.

**Controller Power up Disable Time**

A user can enter the required controller power disable time in this field.

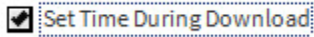


The digital outputs of the controller are disabled for this duration after power-up.

This configuration is ignored by the controller when it is in emergency mode.

A disable time can be set within the range of 1 sec to 300 sec.

## Set Time During Download



'Check' this option to set the controller time during the download operation.

The controller time will be set as per the station's time, which will be used for configuration.

## Daylight Savings Settings

This feature enables to select the Daylight Savings Settings.

The available options enable to select Start Month, Start Day, End Month and End Day as shown in [Figure 41](#).

A screenshot of the "Daylight Savings Settings" form. It includes a checked checkbox for "Enable Daylight Savings". Below this are four dropdown menus: "Start Month" (March), "Start Day" (Second Sunday), "End Month" (November), and "End Day" (First Sunday).

Daylight Savings Settings			
<input checked="" type="checkbox"/>	Enable Daylight Savings		
Start Month	March	Start Day	Second Sunday
End Month	November	End Day	First Sunday

**Figure 41: Daylight Saving Settings**

The tool validates the correct start and end date selection for day light savings. If the start and end date configured are not valid then the tool displays an error and prevents the day light savings configuration from being saved. Examples of invalid date are: February 30<sup>th</sup>, June 31<sup>st</sup>, September 31<sup>st</sup>.



**Note:**

*When Day Light Saving Settings are configured, if user wishes to retain the station's time in the device then select "Set Time During Download".*

## VAV Outputs



To view details of VAV outputs, click 'VAV Outputs' in the left pane.

It displays a 'VAV Output' screen in right pane.

VAV Outputs are used to configure output assignments, output names and output parameters.

**VAV Configuration Wizard**  
Configure Output Assignments, Output Names and Output Parameters

- Configuration
- VAV Outputs**
- VAV Inputs
- Temperature Setpoints
- Flow Setpoints
- Control Parameters
- Schedule
- PID
- Accessory Loops
- Custom Wiring

**VAV Outputs**



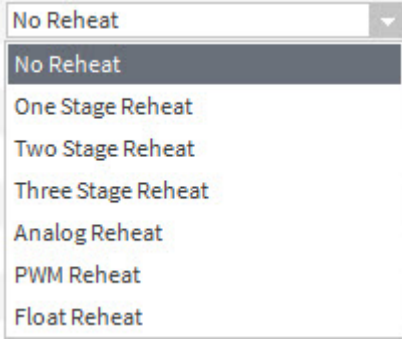
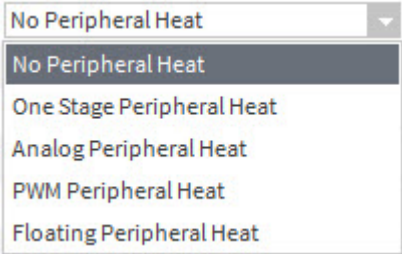
Output	Output Assignment	Output Name
Damper Type	Floating	Damper motor
Reheat Type	No Reheat	Reheat
Peripheral Heating Type	No Peripheral Heat	Peripheral heating
Fan Type	No Fan	Fan
Wall Module Occupancy Status LED	None	Wall Module LED
Auxiliary Digital Output	None	Aux digital out
Auxiliary Pulse On	None	Aux pulse on
Auxiliary Pulse Off	None	Aux pulse off
Free Digital Output	None	Free digital out
Free Analog Output	None	Free analog out
Free Pulse On	None	Free pulse on
Free Pulse Off	None	Free pulse off




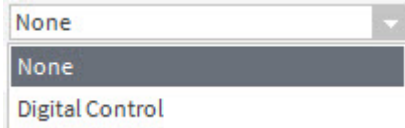
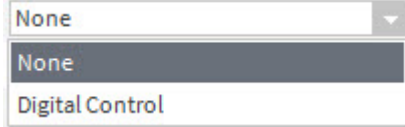
**Output Parameters**

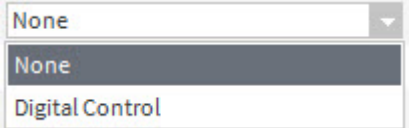
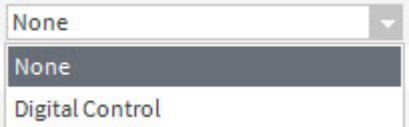
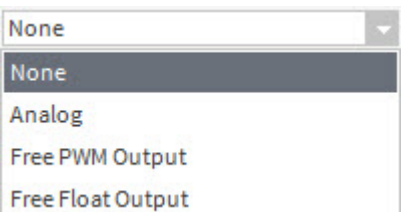
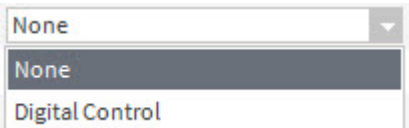
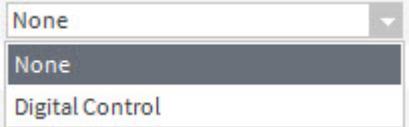
- Damper Motor ▾
- Reheat ▾
- Peripheral Heat ▾
- Fan ▾
- WallModLED ▾
- Heating Sequence ▾
- Free Analog ▾

Figure 42: VAV Outputs window

**Table 1: Main Output Types**

Output	Output Assignment	Description
Damper Type  	Analog	Damper Type enables a user to select the damper motor control type as Analog Control, PWM Control, and Floating Control. For analog Damper type, select this option. For additional parameters related to analog output, refer to <a href="#">Analog Control</a> .
	Floating	For Floating Damper type, select this option. For additional parameters related to floating output, refer to <a href="#">Floating Control</a> .
	PWM	For PWM Damper type, select this option. For additional parameters related to PWM output, refer to <a href="#">PWM Control</a> .
 <b>Note:</b>		<p><i>Floating actuators are recommended for pressure independent control since the Analog or PWM type of actuators do not provide the required resolution for achieving stable flow.</i></p>
Reheat Type  	No Reheat	For the application which do not utilize reheating in the system.
	One Stage Reheat	For single stage reheat type, select this option. One digital output is required.
	Two Stage Reheat	For two stage reheat type, select this option. Two digital outputs are required.
	Three Stage Reheat	For three stage reheat type, select this option. Three digital outputs are required.
	Analog Reheat	For analog actuator, select this option. For additional parameters related to analog output, refer to <a href="#">Analog Reheat</a> .
	PWM Reheat	For PWM type actuator, select this option. For additional parameters related to PWM output, refer to <a href="#">PWM Reheat</a> .
	Float Reheat	For floating type actuator, select this option. For additional parameters related to Float output, refer to <a href="#">Float Reheat</a> .
Peripheral Heating Type  	No Peripheral Heat	For the application not utilizing Peripheral heating equipment.
	One Stage Peripheral Heat	For single stage peripheral heating, select this option. One digital output is required.
	Analog Peripheral Heat	For analog actuator, select this option. For additional parameters related to analog output, refer to <a href="#">Analog Peripheral Heat</a> .
	PWM Peripheral Heat	For PWM type actuator select this option. For additional parameters related to PWM output, refer to <a href="#">PWM Peripheral Heat</a> .
	Floating Peripheral Heat	For floating type actuator, select this option. For additional parameters related to Floating outputs, refer to <a href="#">Floating Peripheral Heat</a> .

Output	Output Assignment	Description
Fan Type  	No Fan	For the application, which do not utilize Fan in the system.
	Series Fan	For the application, utilizing Series Fan in the system
	Parallel Fan Temp Control	For the application, utilizing Parallel Fan for the temperature control in system.
	Parallel Fan Airflow Control	For the application, utilizing Parallel Fan for the airflow control in system.
	Parallel Speed Control - PWM	Select this option if PWM type actuator used for parallel fan speed control. For additional parameters related to PWM output, refer to <a href="#">Parallel Speed Control – PWM</a> .
	Parallel Speed Control - Float	Select this option if Floating type actuator used for parallel fan speed control. For additional parameters related to floating output, refer to <a href="#">Parallel Speed Control – Float</a> .
	Parallel Speed Control - Analog	Select this option if analog type actuator used for parallel fan speed control. For additional parameters related to analog output, refer to <a href="#">Parallel Speed Control – Analog</a> .
Wall Module Occupancy LED  	 <b>Note:</b> This option is enabled when a user selects 'Wall Module Type' as 'Conventional Wall Module'.	
	None	Select this option if user does not want to configure Wall Module Occupancy LED.
	Cool Analog	Select this output to control the LED available on the TR21-series wall modules. For additional parameters related to analog output.
Auxiliary Digital Output  	None	Select this option if no additional auxiliary digital output is configured
	Digital Control	Select this option to configure an additional auxiliary digital output. This output is activated when the effective occupancy is 'Occupied'.
Auxiliary Pulse On  	None	Select this option if no additional output is required for 'Auxiliary Pulse On'.
	Digital Control	Select this option to configure an Auxiliary Pulse On. This output is pulsed when the effective occupancy changes to 'Occupied'.

Output	Output Assignment	Description
Auxiliary Pulse Off  	None	Select this option if no additional output is required for 'Auxiliary Pulse Off'.
	Digital Control	Select this option to configure an Auxiliary Pulse Off. This output is pulsed when the effective occupancy changes to 'Unoccupied'.
Free Digital Output  	None	Select this option if a free digital output is not required.
	Digital Control	Select this option if a free digital output is required to be configured in system.
Free Analog Output  	None	Select this option if a free analog output is not required.
	Analog	Select this option if a free analog output is required to be configured in system.
	Free PWM Output	Select this option if a free PWM output is required to be configured in system.
	Free Float Output	Select this option if a free floating output is required to be configured in system.
Free Pulse On  	None	Select this option if no Free Pulse On is required for 'Auxiliary Pulse On'.
	Digital Control	Select this option to configure a Free Pulse On.
Free Pulse Off  	None	Select this option if no Free Pulse Off is required for 'Auxiliary Pulse Off'.
	Digital Control	Select this option to configure a Free Pulse Off.



**Damper Motor**

For the Output Assignments of Damper Motor, refer to [Figure 43](#)

Output	Output Assignment	Output Name
Damper Type	Analog	Damper motor
Reheat Type	Analog	Reheat
Peripheral Heating Type	Floating	Peripheral heating
Fan Type	PWM	Fan
Wall Module Occupancy Status LED	None	Wall Module LED
Auxiliary Digital Output	None	Aux digital out
Auxiliary Pulse On	None	Aux pulse on
Auxiliary Pulse Off	None	Aux pulse off
Free Digital Output	None	Free digital out
Free Analog Output	None	Free analog out
Free Pulse On	None	Free pulse on
Free Pulse Off	None	Free pulse off

**Output Parameters**  
Damper Motor

**Analog Control**

Analog Output Mode: Voltage

Analog Output Control: 0 to 10 vdc

**Floating Control**

Floating Motor Travel Time: 0.0 s [0.1-3276.7]

Start Up Sync Position: None

Startup Delay: 0.0 s [0.0-3276.7]

Auto Sync Position: None

Auto Sync Interval: 24 hr [0-254]

Action: Direct Acting

Unocc.Sync Position: None

Network Sync Position: None

**PWM Control**

PWM Period: 25.6 s [0.1-3276.7]

PWM Zero Scale: 0.1 s [0.1-3276.7]

PWM Full Scale: 25.5 s [0.1-3276.7]

PWM Full and PWM Zero <= PWM Period

**Figure 43: Output Parameters of Damper Motor**

**Analog Control**

This option enables to enter analog output mode and analog output control for damper motor. Refer to [Figure 44](#).

**Analog Control**

Analog Output Mode: Voltage

Analog Output Control: Voltage

**Analog Control**

Analog Output Mode: Voltage

Analog Output Control: 0 to 10 vdc

**Figure 44: Selecting Analog Control Parameters**

Analog output Mode could be Voltage or current. Select the voltage/current range to meet the final control element signal requirement.

**PWM Control**

This option enables to enter Pulse Width Modulation (PWM) period, zero scale and full scale. Refer to [Figure 45](#).

PWM Control		
PWM Period	<input type="text" value="25.6"/>	s [ 0.1 - 3276.7 ]
PWM Zero Scale	<input type="text" value="0.1"/>	s [ 0.1 - 3276.7 ]
PWM Full Scale	<input type="text" value="25.5"/>	s [ 0.1 - 3276.7 ]
PWM Full and PWM Zero <= PWM Period		

**Figure 45: Selecting PWM Control Parameters**

### Floating Control

This option enables you to enter floating motor travel time, startup sync position, startup delay, auto sync position and auto sync interval. Refer to [Figure 46](#) and [Figure 47](#).

Floating Control		
Floating Motor Travel Time	<input type="text" value="90.0"/>	s [ 0.1 - 3276.7 ]
Start Up Sync Position	<input type="text" value="None"/>	▼
Startup Delay	<input type="text" value="0.0"/>	s [ 0.0 - 3276.7 ]
Auto Sync Position	<input type="text" value="None"/>	▼
Auto Sync Interval	<input type="text" value="24"/>	hr [ 0 - 254 ]
Action	<input type="text" value="Direct Acting"/>	▼
Unocc Sync Position	<input type="text" value="None"/>	▼
Network Sync Position	<input type="text" value="None"/>	▼

**Figure 46: Selecting Floating Control Parameters**

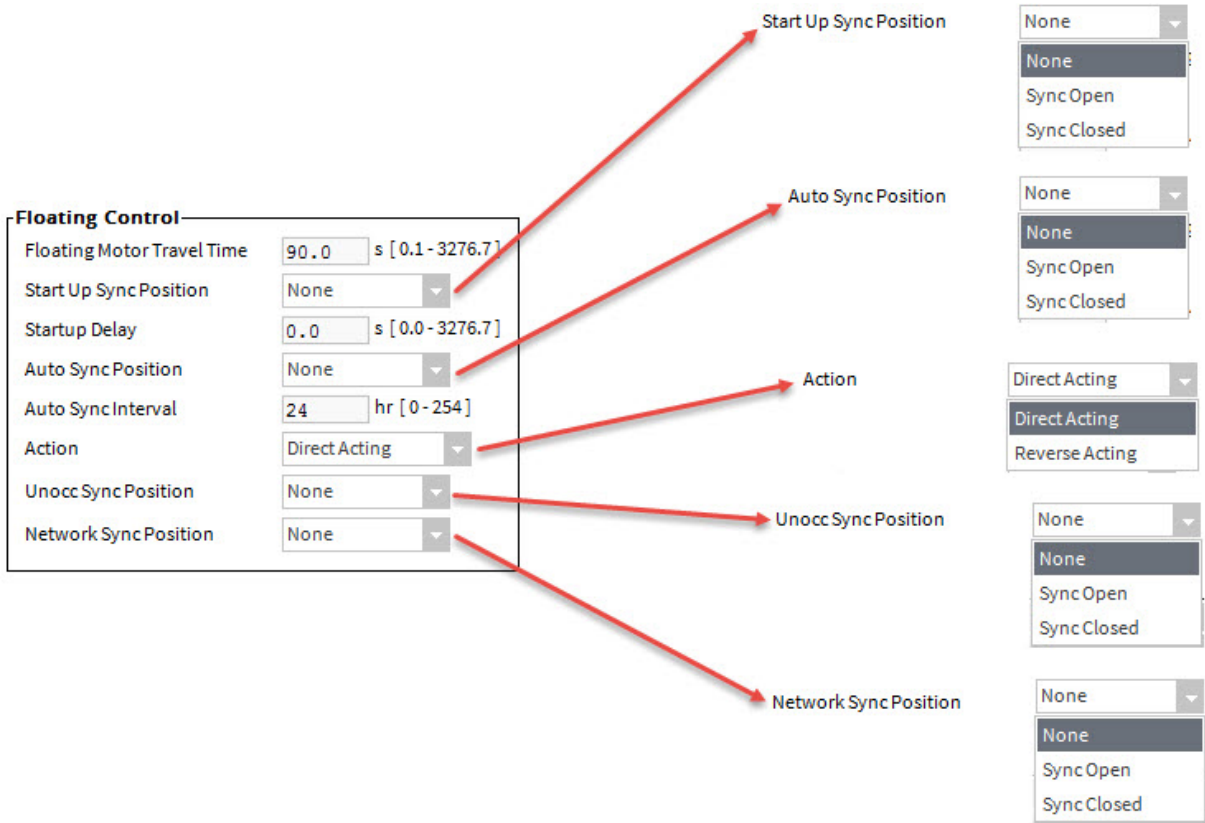


Figure 47: Configuring Floating Control Parameters

**Table 2: Floating Control Parameters**

Floating Control	Parameter Type	Description
Floating Motor Travel Time	-	This indicates the full stroke time of the actuator. It is the time required to move the actuator from full close to full open position.
Start Up Sync Position	None	Select this when no action is required to take after controller power up.
	Sync Open	If this option is selected, then actuator is set to full open position after controller power up.
	Sync Closed	If this option is selected, then actuator is set to full close position after controller power up.
Startup Delay	-	This delay occurs when the controller is powered up. Zero (0) means no delay.
Auto Sync Position	None	If the position of the actuator is not synched automatically then select this option.
	Sync Open	At Auto Sync Interval, floating actuator is synchronized to open position.
	Sync Closed	At Auto Sync Interval, floating actuator is synchronized to close position.
Auto Sync Interval	-	This option is applicable only if the auto synchronization (Sync Open/Sync Close) is selected. It is defined in hour format. On completion of Auto Sync Interval, the motor is synchronized.
Action	Direct Acting	When Direct Acting option is selected, the actuator is set to the default positions of [100 % = Full open; 0 % = Full close].
	Reverse Acting	When Reverse Acting option is selected, the actuator is set to the default positions of [100 % = Full close; 0 % = Full open].
Unocc Sync Position	None	The floating actuator will not be synchronized automatically, when the VAV controller enters Unoccupied mode.
	Sync Open	The actuator is synchronized to open, when the VAV controller enters Unoccupied Mode.
	Sync Closed	The actuator is synchronized to close, when the VAV controller enters Unoccupied Mode.
	Network Input Free2Dig	If this network input is configured as a Sync Input and results in a TRUE condition, then the floating actuator position is synchronized to the position specified by the Sync Input Position.

**Reheat**

In Actuator/without actuator Controller for Reheat following options are available,

1. Up to four stages of reheat
2. Analog Reheat
3. PWM Reheat
4. Float Reheat

User can select any option form mentioned options as per the requirement of the given system.

When 'Analog Reheat', 'PWM Reheat' or 'Float Reheat' is selected as an output assignment, Output parameters section for 'Reheat Section' expands (as shown in [Figure 48](#)) allowing to set parameters for Analog, PWM or Floating control, whichever is selected.

Output	Output Assignment	Output Name
Damper Type	PWM	Damper motor
<b>Reheat Type</b>	Analog Reheat	Reheat
Peripheral Heating Type	No Reheat	Peripheral heating
Fan Type	One Stage Reheat	Fan
Wall Module Occupancy Status LED	Two Stage Reheat	Wall Module LED
Auxiliary Digital Output	Three Stage Reheat	Aux digital out
Auxiliary Pulse On	<b>Analog Reheat</b>	Aux pulse on
Auxiliary Pulse Off	<b>PWM Reheat</b>	Aux pulse off
Free Digital Output	Float Reheat	Free digital out
Free Analog Output	None	Free analog out
Free Pulse On	None	Free pulse on
Free Pulse Off	None	Free pulse off

Output Parameters	
Damper Motor	
Reheat	

**Analog Control**

Analog Output Mode: Voltage

Analog Output Control: 0 to 10 vdc

**PWM Control**

PWM Period: 25.6 s [0.1 - 3276.7]

PWM Zero Scale: 0.1 s [0.1 - 3276.7]

PWM Full Scale: 25.5 s [0.1 - 3276.7]

PWM Full and PWM Zero <= PWM Period

**Floating Control**

Floating Motor Travel Time: 0.0 s [0.1 - 3276.7]

Start Up Sync Position: None

Startup Delay: 0.0 s [0.0 - 3276.7]

Auto Sync Position: None

Auto Sync Interval: 24 hr [0 - 254]

Action: Direct Acting

Unocc Sync Position: None

Network Sync Position: None

Modulate Reheat Flow  Yes  No

Discharge Air Control For Reheat: Normal Sequence

Figure 48: Reheat Analog, PWM and Floating Controls

**Analog Reheat**

When Analog Reheat is selected, Analog Control can be adjusted through Analog Output Mode' and 'Analog Output Control'. Refer to Figure 49.

Analog output Mode could be Voltage or current. Select the voltage/current range to meet the final control element signal requirement.

**Analog Control**

Analog Output Mode: Voltage

Analog Output Control: Voltage

**Analog Control**

Analog Output Mode: Voltage

Analog Output Control: 0 to 10 vdc

Figure 49: Selecting Analog Control Parameters

**PWM Reheat**

When PWM Reheat is selected, PWM Control can be adjusted through different parameters as shown in Figure 50.

**PWM Control**

PWM Period: 25.6 s [0.1 - 3276.7]

PWM Zero Scale: 0.1 s [0.1 - 3276.7]

PWM Full Scale: 25.5 s [0.1 - 3276.7]

PWM Full and PWM Zero <= PWM Period

Figure 50: Selecting PWM Control Parameters

**Float Reheat**

When Float Reheat is selected, Floating Control can be adjusted as shown in

For more details on Floating Control parameters, refer to [Table 2](#).



**Figure 51: Selecting Float Reheat Floating Control Parameters**

**Modulate Reheat Flow**

It enables a user to configure whether airflow and damper should be controlled (between minimum position and fixed reheat position) according to the temperature control loop.

**Modulate Reheat Flow**  Yes  No

Modulate Reheat Flow can be enabled/disabled by selecting the required option.

**Discharge Air Control for Reheat**

Discharge Air Control For Reheat  Normal Sequence  Normal Sequence  Discharge Air Control Sequence

**Normal Sequence:** A user can select this option if a Normal Sequence is required.

**Discharge Air Control Sequence:** A user can select this option if Discharged Air Control Sequence is required in the application.



## Peripheral Heating Type

Output	Output Assignment	Output Name
Damper Type	Floating	Damper motor
Reheat Type	No Reheat	Reheat
<b>Peripheral Heating Type</b>	Analog Peripheral Heat	<b>Peripheral heating</b>
Fan Type	No Peripheral Heat	Fan
Wall Module Occupancy Status LED	One Stage Peripheral Heat	Wall Module LED
Auxiliary Digital Output	Analog Peripheral Heat	Aux digital out
Auxiliary Pulse On	PWM Peripheral Heat	Aux pulse on
Auxiliary Pulse Off	Floating Peripheral Heat	Aux pulse off
Free Digital Output	None	Free digital out
Free Analog Output	None	Free analog out
Free Pulse On	None	Free pulse on
Free Pulse Off	None	Free pulse off

Output Parameters	
Damper Motor	
Reheat	
<b>Peripheral Heat</b>	

**Analog Control**

Analog Output Mode: Voltage

Analog Output Control: 0 to 10 vdc

---

**PWM Control**

PWM Period: 25.6 s [0.1 - 3276.7]

PWM Zero Scale: 0.1 s [0.1 - 3276.7]

PWM Full Scale: 25.5 s [0.1 - 3276.7]

PWM Full and PWM Zero <= PWM Period

**Floating Control**

Floating Motor Travel Time: 0.0 s [0.1 - 3276.7]

Start Up Sync Position: None

Startup Delay: 0.0 s [0.0 - 3276.7]

Auto Sync Position: None

Auto Sync Interval: 24 hr [0 - 254]

Action: Direct Acting

Unocc Sync Position: None

Network Sync Position: None

Peripheral Minimum Position: 0.0 % [0.0 - 100.0]

Figure 52: Peripheral Heating Type

### Analog Peripheral Heat

When Analog Peripheral Reheat is selected, Analog Control can be adjusted through Analog Output Mode' and 'Analog Output Control'. Refer to [Figure 53](#).

Analog output Mode could be Voltage or current. Select the voltage/current range to meet the final control element signal requirement.

**Analog Control**

Analog Output Mode: Voltage

Analog Output Control: Voltage

**Analog Control**

Analog Output Mode: Voltage

Analog Output Control: 0 to 10 vdc

Figure 53: Selecting Peripheral Analog Reheat Control Parameters

### PWM Peripheral Heat

When PWM Peripheral Reheat is selected, PWM Control can be adjusted through different parameters as shown in [Figure 54](#).

**PWM Control**

PWM Period: 25.6 s [0.1 - 3276.7]

PWM Zero Scale: 0.1 s [0.1 - 3276.7]

PWM Full Scale: 25.5 s [0.1 - 3276.7]

PWM Full and PWM Zero <= PWM Period

Figure 54: Selecting PWM Control Parameters

### Floating Peripheral Heat

When Floating Peripheral Heat is selected, Floating Controls can be adjusted as shown in [Figure 55](#).

For more details on Floating Control parameters, refer to [Table 2](#).

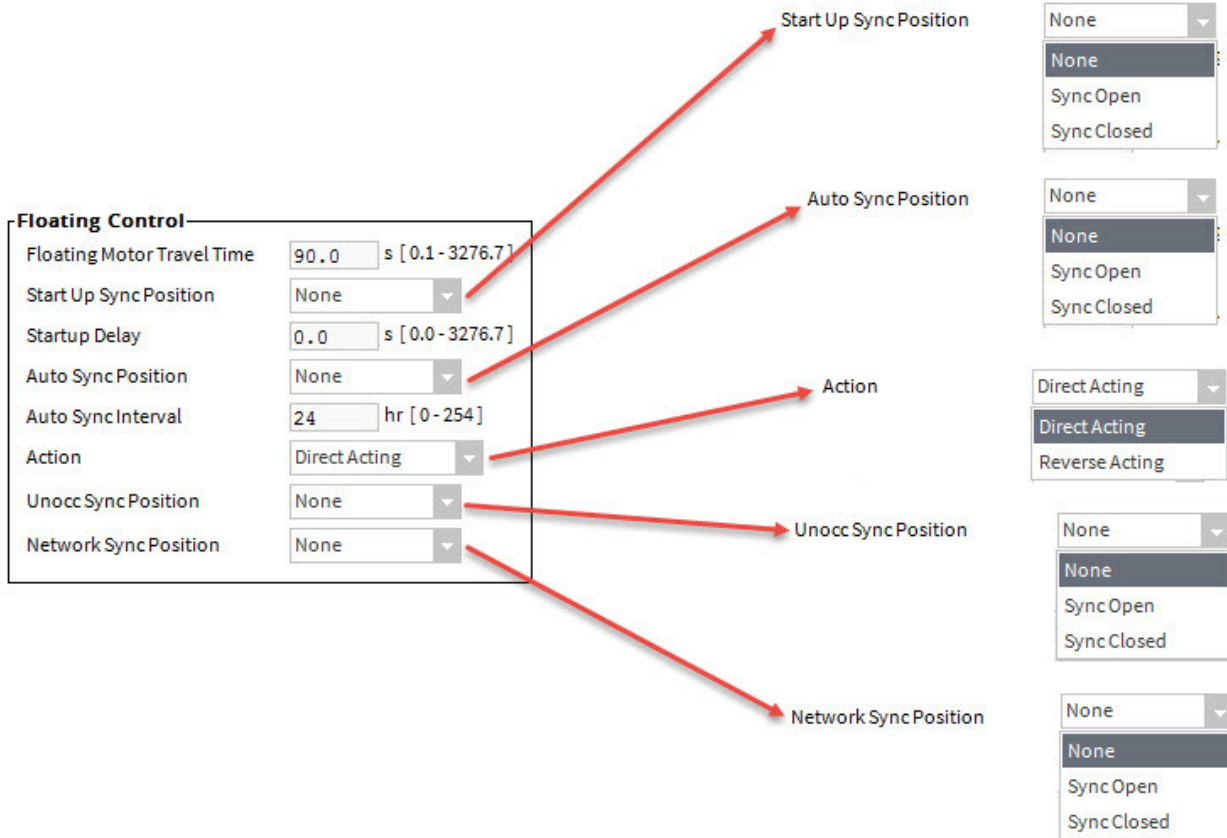


Figure 55: Floating Peripheral Heat

### Peripheral Minimum Position

Peripheral Minimum Position  % [0.0 - 100.0]

This feature can be used to maintain flow in pipes that may otherwise freeze. If the outdoor air temperature value is connected to the zone terminal, the minimum position is active when the outdoor air temperature is below 40 °F.



## Fan Type

Output	Output Assignment	Output Name
Damper Type	Floating	Damper motor
Reheat Type	No Reheat	Reheat
Peripheral Heating Type	No Peripheral Heat	Peripheral heating
<b>Fan Type</b>	Parallel Speed Control - Analog	Fan
Wall Module Occupancy Status LED	No Fan	Wall Module LED
Auxiliary Digital Output	Series Fan	Aux digital out
Auxiliary Pulse On	Parallel Fan Temp Control	Aux pulse on
Auxiliary Pulse Off	Parallel Fan Air Flow Control	Aux pulse off
Free Digital Output	Parallel Speed Control - PWM	Free digital out
Free Analog Output	Parallel Speed Control - Float	Free analog out
Free Pulse On	Parallel Speed Control - Analog	Free pulse on
Free Pulse Off	None	Free pulse off

Output Parameters	
Damper Motor	▼
Reheat	▼
Peripheral Heat	▼
Fan	▲

**Analog Control**

Analog Output Mode: Voltage

Analog Output Control: 0 to 10 vdc

**PWM Control**

PWM Period: 25.6 s [0.1 - 3276.7]

PWM Zero Scale: 0.1 s [0.1 - 3276.7]

PWM Full Scale: 25.5 s [0.1 - 3276.7]

PWM Full and PWM Zero <= PWM Period

**Floating Control**

Floating Motor Travel Time: 0.0 s [0.1 - 3276.7]

Start Up Sync Position: None

Startup Delay: 0.0 s [0.0 - 3276.7]

Auto Sync Position: None

Auto Sync Interval: 24 hr [0 - 254]

Action: Direct Acting

Unocc Sync Position: None

Network Sync Position: None

Figure 56: Fan Type

### Parallel Speed Control – Analog

When Parallel Speed Control is selected, Analog Control can be adjusted through Analog Output Mode' and 'Analog Output Control'. Refer to [Figure 57](#).

### Parallel Speed Control – PWM

When PWM control is selected for Parallel speed control, PWM Control can be adjusted through different parameters as shown in [Figure 58](#).

**Analog Control**

Analog Output Mode: Voltage

Analog Output Control: Voltage

**Analog Control**

Analog Output Mode: Voltage

Analog Output Control: 0 to 10 vdc

- 0 to 10 vdc
- 10 to 0 vdc
- 2 to 10 vdc
- 10 to 2 vdc

**PWM Control**

PWM Period: 25.6 s [0.1 - 3276.7]

PWM Zero Scale: 0.1 s [0.1 - 3276.7]

PWM Full Scale: 25.5 s [0.1 - 3276.7]

PWM Full and PWM Zero <= PWM Period

Figure 58: PWM Control Parameters

Figure 57: Parallel Speed Control – Analog Control Parameters

**Parallel Speed Control – Float**

When Floating control is selected for Parallel speed control, Float Control can be adjusted through different parameters as shown in [Figure 59](#).

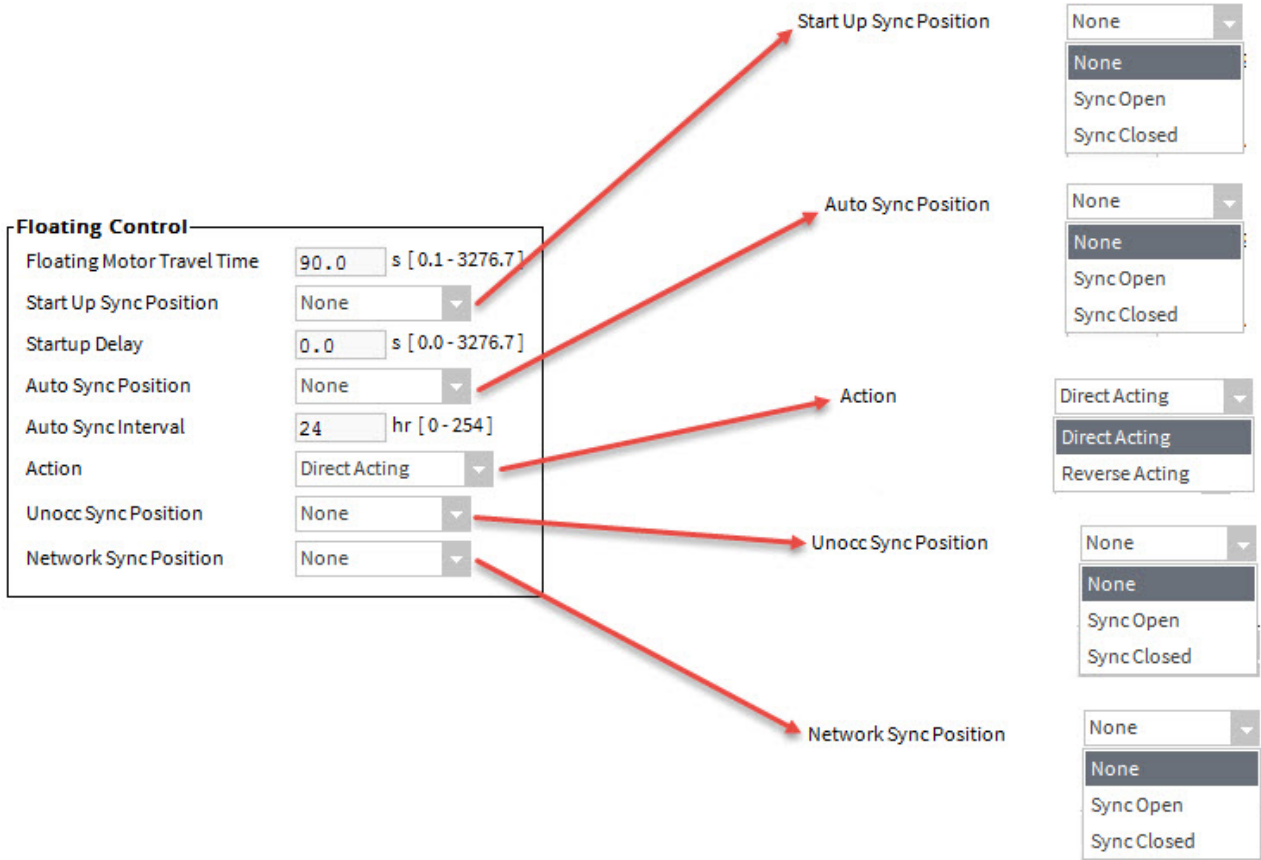


Figure 59: Floating Control Parameters for Parallel Speed Control

For more details on Floating Control parameters, refer to [Table 2](#)

## Free Analog Output

Output	Output Assignment	Output Name
Damper Type	Floating	Damper motor
Reheat Type	No Reheat	Reheat
Peripheral Heating Type	No Peripheral Heat	Peripheral heating
Fan Type	No Fan	Fan
Wall Module Occupancy Status LED	None	Wall Module LED
Auxiliary Digital Output	None	Aux digital out
Auxiliary Pulse On	None	Aux pulse on
Auxiliary Pulse Off	None	Aux pulse off
Free Digital Output	None	Free digital out
<b>Free Analog Output</b>	Analog	<b>Free analog out</b>
Free Pulse On	None	Free pulse on
Free Pulse Off	Analog	Free pulse off

Output Parameters	
Damper Motor	Free PWM Output
Reheat	Free Float Output
Peripheral Heat	
Fan	
WallModLED	
Heating Sequence	
Free Analog	

**Analog Control**

Analog Output Mode: Voltage

Analog Output Control: 0 to 10 vdc

---

**PWM Control**

PWM Period: 25.6 s [0.1 - 3276.7]

PWM Zero Scale: 0.1 s [0.1 - 3276.7]

PWM Full Scale: 25.5 s [0.1 - 3276.7]

PWM Full and PWM Zero <= PWM Period

**Floating Control**

Floating Motor Travel Time: 0.0 s [0.1 - 3276.7]

Start Up Sync Position: None

Startup Delay: 0.0 s [0.0 - 3276.7]

Auto Sync Position: None

Auto Sync Interval: 24 hr [0 - 254]

Action: Direct Acting

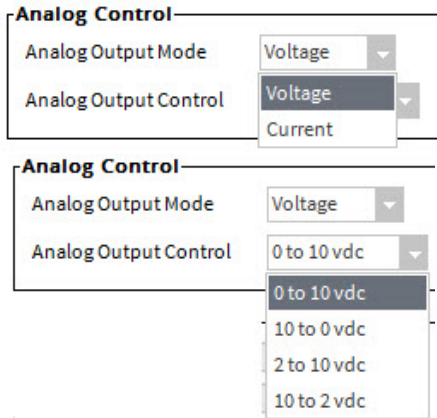
Unocc Sync Position: None

Network Sync Position: None

Figure 60: Free Analog Output

### Analog Control

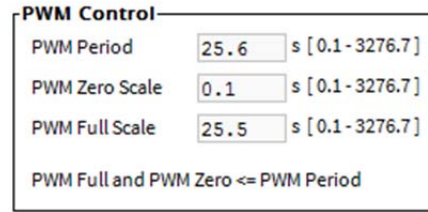
When Analog Control for 'Free Analog Output' is selected, Analog Control can be adjusted through Free Analog section. Refer to [Figure 61](#).



**Figure 61: Selecting Free Analog Output – Analog Control Parameters**

### Free PWM Output

When a free PWM output is configured, its control can be adjusted through different parameters as shown in [Figure 62](#).

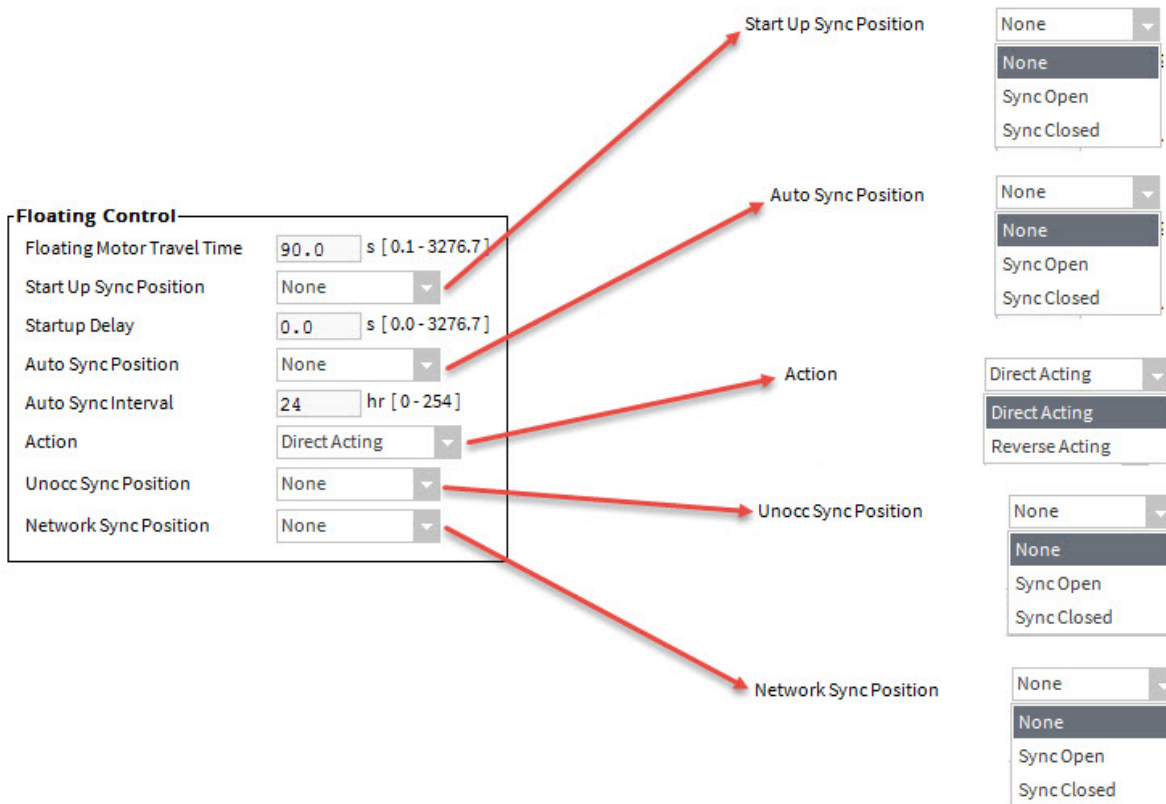


**Figure 62: PWM Control Parameters**

### Free Float Output

When a free floating output is configured, its control can be adjusted through different parameters as shown [Figure 63](#).

For more details on Floating Control parameters, refer to [Table 2](#)



**Figure 63: Free Float Output**

## VAV Inputs



To view details of VAV Inputs, click 'VAV Inputs' in the left pane.

It displays a 'VAV Inputs' screen in right pane. Refer to [Figure 64](#).

This screen allows user to configure the inputs as per the application requirement. This is also used to configure the optional 10-point custom sensor curves.

There is an Input tab available.

The 'Custom Sensors' tab can be used to configure 10-point custom sensor curves.

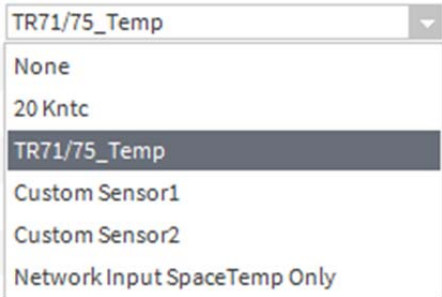
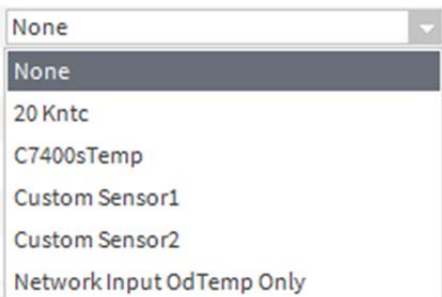
VAV Inputs		
Inputs		
Input	Input Source	Input Name
Space Temperature	TR71/75_Temp	Space temp
Outdoor Air Temperature	None	Outdoor temp
Wall Module Occupancy Override	None	Zone override
Discharge Temperature	None	Discharge temp
Space Temperature Setpoint	TR71/75_Setpoint	Set point
Supply Temperature	Network Input SupplyTemp Only	Supply temp
Airflow Velocity Pressure	OnBrdPress	Air flow
Input Parameters		
Space Temperature Setpoint (Space Temp Stpt)		▼
Zio Wall Module		▼
Occupancy Sensor		▼

Figure 64: VAV Inputs

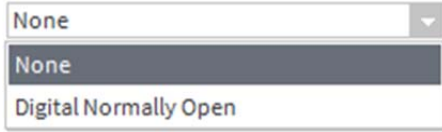
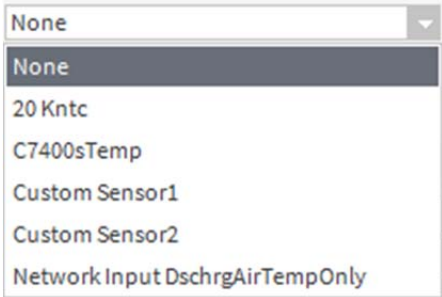
## Inputs

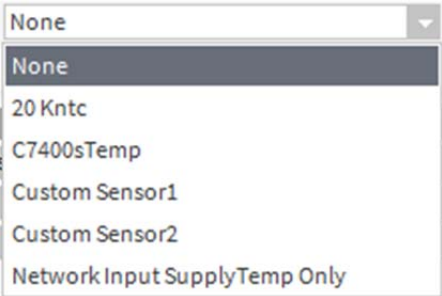
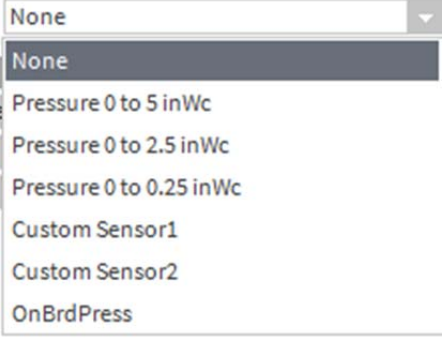
Table 3 shows the VAV Input types with Input Source and their Description.

**Table 3: Inputs**

Input	Input Source	Description
Space Temperature 	None	If return air temperature is selected as a controlling element and space temperature is not required, select this option.
	20 Kntc	Select this option if a temperature sensor of 20 Kntc characteristics is configured to the system.
	TR71/75_Temp	Select this option when Wall Module type is 'TR71/75 Wall Module'.
	Custom Sensor 1	If the space temperature is with custom characteristics, then select this option.  Configure the sensor characteristics in Custom Sensor 1. Refer to <a href="#">Custom Sensors</a> .
	Custom Sensor 2	If the space temperature is with custom characteristics, then select this option.  Configure the sensor characteristics in Custom Sensor 2. Refer to <a href="#">Custom Sensors</a> .
	Network Input Space Temp Only	Space temperature will be communicated over BACnet® network through supervisory controller when this option is selected.
Outdoor Air Temperature 	None	If outdoor air temperature is not required, select this option.
	20 Kntc	Select this option if a temperature sensor of 20 Kntc characteristics is configured to the system.
	C7400sTemp	If C7400S SYLK bus enabled sensor is utilized in the application for outdoor air temperature, select this option.
	Custom Sensor 1	If the outdoor air temperature is with custom characteristics, then select this option.  Configure the sensor characteristics in Custom Sensor 1. Refer to <a href="#">Custom Sensors</a> .
	Custom Sensor 2	If the outdoor air temperature is with custom characteristics, then select this option.  Configure the sensor characteristics in Custom Sensor 2. Refer to <a href="#">Custom</a>



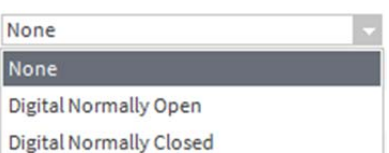



Input	Input Source	Description
		<a href="#">Sensors.</a>
	Network Input OdTemp Only	Outdoor air temperature will be communicated over BACnet® network through supervisory controller when this option is selected.
Wall Module Occupancy Override 	None	Select this option. If Occupancy Override from the wall module is not required in the application.
	Digitally Normally Open	Select this option. If Occupancy Override from the wall module is required in the application.
Discharge Temperature 	None	If the discharge air temperature is not required, select this option.
	20 Kntc	Select this option if a temperature sensor of 20 Kntc characteristics is configured to the system.
	C7400sTemp	If C7400S SYLK bus enabled sensor is utilized in the application for discharge air temperature, select this option
	Custom Sensor 1	If the discharge air temperature is with custom characteristics, then select this option. Configure the sensor characteristics in Custom Sensor 1. Refer to <a href="#">Custom Sensors.</a>
	Custom Sensor 2	If the discharge air temperature is with custom characteristics, then select this option. Configure the sensor characteristics in Custom Sensor 2. Refer to <a href="#">Custom Sensors.</a>
	Network input DschrgAirTempOnly	Discharge air temperature will be communicated over BACnet® network through supervisory controller when this option is selected.
Space Temperature Setpoint 	None	If the space temperature setpoint is not set through the TR71/75 wall module, select this option.
	TR71/75 Setpoint	If the space temperature setpoint needs to be set through the TR71/75 Wall module, select this option. Refer to <a href="#">Zio Wall Module.</a>
Supply Temperature	None	If the supply air temperature is not required, select this option.
	20 Kntc	Select this option if a temperature sensor of 20 Kntc characteristics is configured to the system.
	C7400STemp	If C7400S SYLK bus enabled sensor is utilized in the application for supply air temperature, select

Input	Input Source	Description
		this option
	Custom Sensor 1	If the Supply Temperature is with custom characteristics, then select this option. Configure the sensor characteristics in Custom Sensor 1. Refer to <a href="#">Custom Sensors</a> .
	Custom Sensor 2	If the space humidity is with custom characteristics, then select this option. Configure the sensor characteristics in Custom Sensor 2. Refer to <a href="#">Custom Sensors</a> .
	Network Input SupplyTempOnly	Supply temperature will be communicated over BACnet® network through supervisory controller when this option is selected.
Airflow Velocity Pressure  	None	If the airflow velocity pressure is not required, select this option.
	Pressure 0 to 5 inWc	If the airflow velocity pressure sensor is set with 0 inWc to 5 inWc range, select this option.
	Pressure 0 to 2.5 inWc	If the airflow velocity pressure sensor is set with 0 inWc to 2.5 inWc range, select this option.
	Pressure 0 to 0.25 inWc	If the airflow velocity pressure sensor is set with 0 inWc to 0.25 inWc range, select this option.
	Custom Sensor 1	If the airflow velocity pressure is with custom characteristics, then select this option. Configure the sensor characteristics in Custom Sensor 1. Refer to <a href="#">Custom Sensors</a> .
	Custom Sensor 2	If the airflow velocity pressure is with custom characteristics, then select this option. Configure the sensor characteristics in Custom Sensor 2. Refer to <a href="#">Custom Sensors</a> .
	OnBrdPress	If an on board pressure sensor is configured, select this option.
Space Relative Humidity	None	If the space relative humidity is not required, select this option.
	0 to 10V	If the space sensor in the application produces 0-10 V for 0-100 % relative humidity value, select this option.
	2 to 10 V	If the space sensor in the application is produces 2-10 V for 0-100 % relative humidity value,

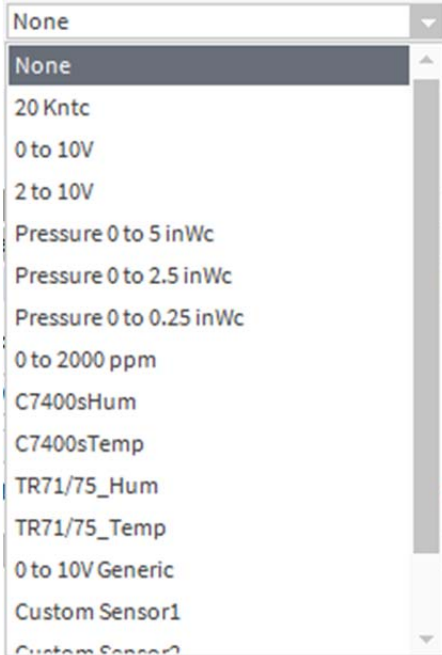


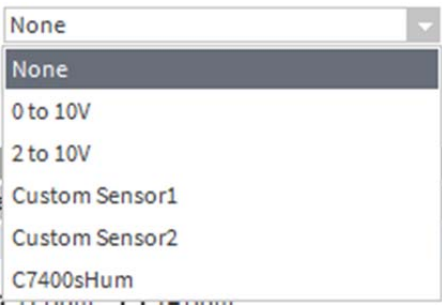
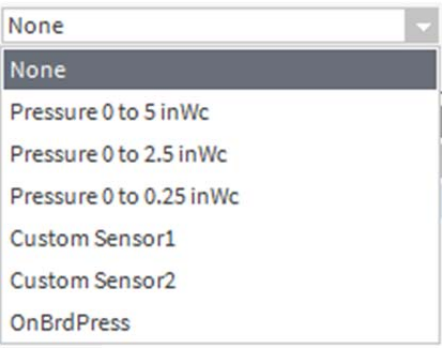
Input	Input Source	Description
<div style="border: 1px solid gray; padding: 5px;"> <input type="text" value="None"/> <ul style="list-style-type: none"> <li style="background-color: #e0e0e0; padding: 2px;">None</li> <li style="padding: 2px;">0 to 10V</li> <li style="padding: 2px;">2 to 10V</li> <li style="padding: 2px;">TR71/75_Hum</li> <li style="padding: 2px;">C7400sHum</li> <li style="padding: 2px;">Custom Sensor1</li> <li style="padding: 2px;">Custom Sensor2</li> <li style="padding: 2px;">Network Input SpaceHum Only</li> </ul> </div>		select this option.
	TR71/75_Hum	If TR71/75 wall module is with space humidity sensor, after selection of this option, VAV controller utilizes relative humidity value provided by the TR71/75 if this setting is selected.
	C7400s_Hum	If C7400S SYLK bus enabled sensor is utilized in the application, select this option
	Custom Sensor 1	If the space humidity is with custom characteristics, then select this option. Configure the sensor characteristics in Custom Sensor 1. Refer to <a href="#">Custom Sensors</a> .
	Custom Sensor 2	If the space humidity is with custom characteristics, then select this option. Configure the sensor characteristics in Custom Sensor 2. Refer to <a href="#">Custom Sensors</a> .
	Network Input SpaceHum Only	Space relative humidity will be communicated over BACnet® network through supervisory controller when this option is selected.
Space CO2	None	If the space CO2 is not required, select this option.
	0 to 2000 ppm	If the CO2 sensor has the range from 0 ppm - 2000 ppm, select this option.
	Custom Sensor 1	If the space CO2 is with custom characteristics, then select this option. Configure the sensor characteristics in Custom Sensor 1. Refer to <a href="#">Custom Sensors</a> .
	Custom Sensor 2	If the space CO2 is with custom characteristics, then select this option. Configure the sensor characteristics in Custom Sensor 2. Refer to <a href="#">Custom Sensors</a> .
	Network input SpaceCO2 Only	Select this option when space CO2 value is passed to the VAV controller over a BACnet network.
Heat Cool Changeover Switch	None	If the Heat Cool Changeover Switch is not required, select this option.
	Digital Normally Open	As it is normally open, Select this option when Heat Cool Changeover Switch is required.

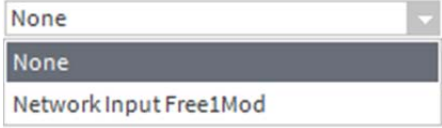
Input	Input Source	Description
		As it is normally open, False=Open True=Close
	Digital Normally Closed	As it is normally closed, Select this option when Heat Cool Changeover Switch is required. As it is normally Closed False=Close True=Open
<p>Monitor Switch</p> 	None	If Monitor Switch is not required in the application, select this option.
	Digital Normally Open	As it is normally open, Select this option when Monitor Switch is required. As it is normally open, False=Open True=Close
	Digital Normally Closed	As it is normally closed, Select this option when Monitor Switch is required. As it is normally Closed False=Close True=Open
<p>Occupancy Sensor</p> 	None	If occupancy sensor is not required in the application, select this option.
	Digital Normally Open	As it is normally open, Select this option when Occupancy Sensor is required. As it is normally open, False=Open True=Close
	Digital Normally Closed	As it is normally closed, Select this option when Occupancy Sensor is required. As it is normally Closed False=Close True=Open
<p>Window Open</p> 	None	If Freeze Protection Mode is not required, select this option.
	Digital Normally Open	Select this option when Shutdown Switch is required. As it is normally open, False=Open True=Close
	Digital Normally Closed	Select this option when Shutdown Switch is required. As it is normally Closed False=Close True=Open

Input	Input Source	Description
Monitor Sensor	None	Select this option if Monitor Sensor is not required.
	20 Kntc	Select the temperature sensor with 20 Kntc characteristics.
	0 to 10Vdc	If the sensor is required with 0 V to 10 Vdc signal, select this option.
	2 to 10Vdc	If the sensor is required with 2 Vdc to 10 Vdc signal, select this option.
	Pressure 0 to 5 inWc	If pressure sensor is set with 0 inWc to 5 inWc range, select this option
	Pressure 0 to 2.5 inWc	If pressure sensor is set with 0 inWc to 2.5 inWc range, select this option
	Pressure 0 to 0.25 inWc	If pressure sensor is set with 0 inWc to 0.25 inWc range, select this option.
	0 to 2000 ppm	If the CO <sub>2</sub> sensor has the range from 0 ppm -2000 ppm, select this option.
	C7400sHum	If C7400S_Hum SYLK bus enabled sensor is utilized, select this option.
	C7400sTemp	If C7400S_Temp SYLK bus enabled sensor is utilized in the application, select this option
	TR71/75_Hum	Select this option if TR71/75 wall module has humidity sensor.
	TR71/75_Temp	Select this option if TR71/75 wall module has temperature sensor.
	0 to 10v Generic	If the sensor is required with 0 to 10 Vdc signal, select this option.
	Custom Sensor 1	In the custom sensor selection, user can define input and output characteristics of the signal. Select custom sensor if sensor has different characteristics than available option. Refer to <a href="#">Custom Sensors</a> for defining custom sensor 1 parameters to configure custom sensor 1 characteristics.
Custom Sensor 2	In the custom sensor selection, user can define input and output characteristics of the signal. Select custom sensor if sensor has different characteristics than available option. Refer to <a href="#">Custom Sensors</a> for defining custom sensor 2 parameters to configure custom sensor 2 characteristics.	
OnBrdPress	If an on board pressure sensor is configured, select this option.	
Outdoor Humidity	None	If the outdoor relative humidity is not

Monitor Sensor



Input	Input Source	Description
		required, select this option.
	0 to 10V	If the outdoor sensor in the application produces 0-10 Vdc for 0-100 % relative humidity value, select this option.
	2 to 10V	If the outdoor sensor in the application produces 2-10 Vdc for 0-100 % relative humidity value, select this option.
	Custom Sensor 1	If the outdoor humidity is with custom characteristics, then select this option. Configure the sensor characteristics in Custom Sensor 1. Refer to <a href="#">Custom Sensors</a> .
	Custom Sensor 2	If the outdoor humidity is with custom characteristics, then select this option. Configure the sensor characteristics in Custom Sensor 2. Refer to <a href="#">Custom Sensors</a> .
	C7400sHum	If C7400S SYLK bus enabled sensor is utilized in the application, select this option
	<p>Static Pressure</p> 	None
Pressure 0 to 5 inWc		If pressure sensor is set with 0 inWc to 5 inWc range, select this option.
Pressure 0 to 2.5 inWc		If pressure sensor is set with 0 inWc to 2.5 inWc range, select this option
Pressure 0 to 0.25 inWc		If pressure sensor is set with 0 inWc to 0.25 inWc range, select this option.
Custom Sensor 1		If the static pressure is with custom characteristics, then select this option. Configure the sensor characteristics in Custom Sensor 1. Refer to <a href="#">Custom Sensors</a> .
Custom Sensor 2		If the static pressure is with custom characteristics, then select this option. Configure the sensor characteristics in Custom Sensor 2. Refer to <a href="#">Custom Sensors</a>
OnBRDPress		If an on board pressure sensor is required, select this option.

Input	Input Source	Description
Peripheral Heat Min Position 	None	Select this option if no inputs are required for Peripheral Heat Minimum Position.
	Network Input Free1Mode	Free modulating output: The output is controlled from the network command.  Output Type: PWM, Float, Analog Current or Voltage  Default: Undefined $0 \leq \text{range} \leq 255$

**Space Temperature Setpoint (Space Temp Stpt)**

This field is enabled when the input for 'Space Temperature Setpoint' is selected as 'TR2x Setpoint'.



Figure 65: Space Temperature Setpoint

**Set Point Knob Type:** The Set Point Knob Type can be configured as Absolute or Relative. This option is applicable only when using a TR2x type of wall module.

**Zio Wall Module**

When Input source for 'Space Temperature' is selected as TR71/75\_Temp, a 'Zio Wall Module' section gets enabled as shown in [Figure 66](#)

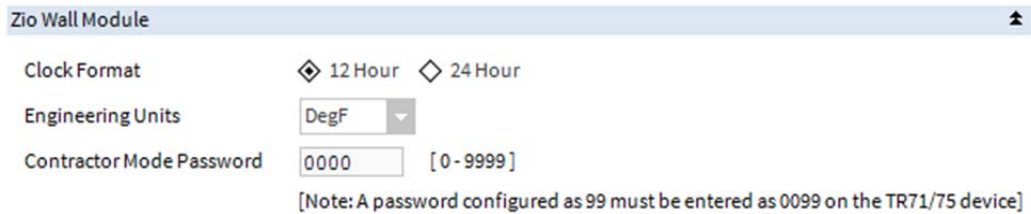


Figure 66: Zio Wall Module

**Clock Format**

A user can select a clock format as 12 hr format or 24 hr format.

**Engineering Units**

In TR71/75 wall module, two options are available for temperature units, DegF and DegC.



Figure 67: Engineering Units

The LCD display will show the temperature parameters according to Engineering Unit selection.

**Contractor Mode password**

In order to restrict the access to only authorized person (or contractor) 'Contractor Mode Password' is provided. The default password is 0000.

Password can be changed as per the preference.

**Occupancy Sensor**

When Input source for 'Occupancy Sensor' is selected as Digitally Normally Open or Digitally Normally Closed, an 'Occupancy Sensor' section expands shown in Figure 68.

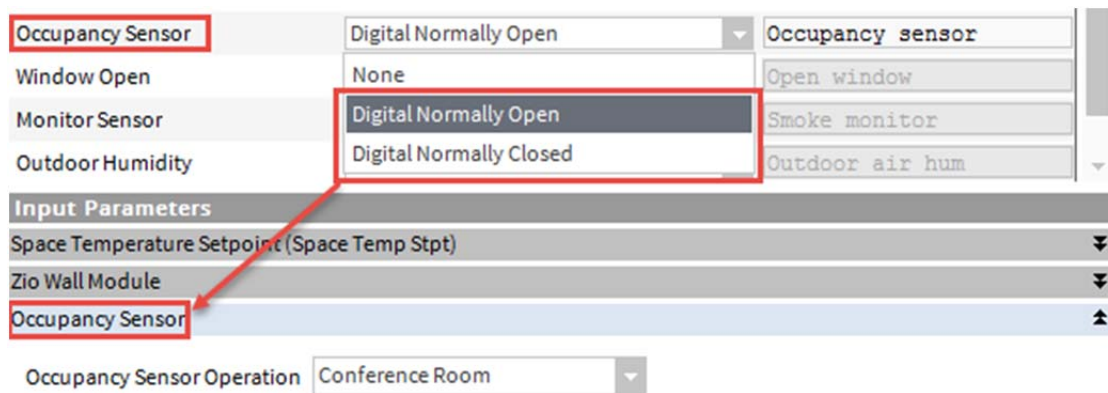


Figure 68: Occupancy sensor

**Occupancy Sensor Operation**

When an [Occupancy Sensor](#) is configured, a tab under 'Input Parameters' expands, enables to configure control operations to determine the behavior during scheduled unoccupied modes. Refer to [Figure 69](#).

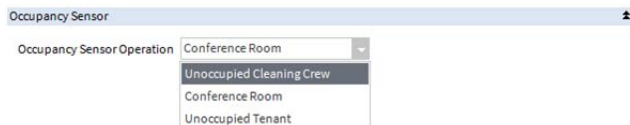


Figure 69: Occupancy Sensor Operation

Standby Mode for comfort of the cleaning crew. During this mode, the system maintains Standby Setpoints.

**Conference Room:** In this mode, the system remains in Unoccupied Mode even if the sensor senses occupancy. This is energy saving mode.

**Unoccupied Tenant:** When this option is selected, the system will be switched to Occupied Mode when the occupancy sensor detects occupancy.

**Unoccupied Cleaning Crew:** When this option is selected, Occupancy Mode will be switched to the

## Custom Sensors

Click on 'Custom Sensors' tab to open custom sensors parameter settings as shown in [Figure 70](#).

Maximum of two Custom Sensors can be configured with the controller.

The screenshot shows the 'Custom Sensors' configuration window. It is divided into two sections: 'Custom Sensor 1' and 'Custom Sensor 2'. Each section contains the following fields:

- Sensor Name:** Custom Sensor1 (for Sensor 1) and Custom Sensor2 (for Sensor 2).
- Sensor Type:** Resistive (selected for both).
- Unit Measure:** Temperature (for Sensor 1) and Speed (for Sensor 2).
- Specification sheet Unit Type:** Celsius (for Sensor 1) and Meters Per Second (for Sensor 2).
- Application Unit Type:** Fahrenheit (for Sensor 1) and Meters Per Second (for Sensor 2).

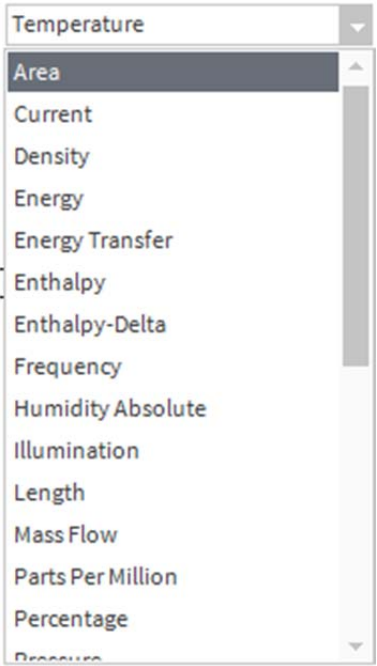


Each sensor configuration also includes 'Import' and 'Export' buttons. To the right of each configuration is a 'Points' table with 5 rows (Point 1 to Point 5) and 3 columns: Point, Input Value (Ω), and Output Value (°C for Sensor 1, m/s for Sensor 2). All input and output values are currently set to 0.0. Below the points table, the 'Input Value Range' is specified as '0 to 300000 Ω'.

Figure 70: Custom Sensors

Table 3 shows different Inputs for Custom Sensor which can be configured as per the requirement.

Table 4: Custom Sensors

Input	Input Source	Description
Sensor Name <input type="text" value="Custom Sensor1"/>	Custom Sensor 1/ Custom Sensor 2	Custom sensor type is configured when using custom sensors with the controller. It allows creating maximum of two sensor types.  Once the sensor is configured, the same sensor name is updated in the Input Source drop-down list.
Sensor Type <input type="text" value="Resistive"/>	None Voltage Resistive	Select this option if no custom sensor is required.  If the sensor output signal is of voltage type.  If the sensor output signal is of resistive type.

Input	Input Source	Description
<p>Unit Measure</p> 	<ul style="list-style-type: none"> <li>Area</li> <li>Current</li> <li>Density</li> <li>Energy</li> <li>Energy Transfer</li> <li>Enthalpy</li> <li>Enthalpy-Delta</li> <li>Frequency</li> <li>Humidity Absolute</li> <li>Illumination</li> <li>Length</li> <li>Mass Flow</li> <li>Parts per million</li> <li>Percentage</li> <li>Pressure</li> <li>Resistance</li> <li>Revolution</li> <li>Speed</li> <li>Temperature</li> <li>Temperature-Delta</li> <li>Temperature-Delta per Time</li> <li>Time</li> <li>Unit-less</li> <li>Voltage</li> <li>Volume</li> <li>Volumetric Flow</li> <li>mass</li> </ul>	<p>Displays all unit categories supported by the controller. Select the required unit from the list.</p>
<p>Specification Sheet Unit Type</p> 	<p>VAL - float</p>	<p>Select required unit type amongst the available options.          Depending upon the selection of 'Unit Measure', the unit type changes.          For example, if Unit Measure is selected as 'Temperature', the 'Specification Sheet Unit Type' will be:</p> 



Input	Input Source	Description
Application Unit Type <input type="text" value="VAL-float"/> <input type="text" value="VAL-float"/>	VAL - float	Select required unit type amongst the available options. Application Unit Type changes as per 'Unit Measure' selection. Depending upon the selection of 'Unit Measure', the unit type changes. For example, if Unit Measure is selected as 'Temperature', the 'Application Unit type' will be: <input type="text" value="Celsius"/> <input type="text" value="Celsius"/> <input type="text" value="Kelvin"/> <input type="text" value="Fahrenheit"/>

**Points**

With the help of these 10 points, custom sensor curves can be configured.

The 'Input Value' depends on type of sensor selected, i.e. either Voltage or Resistive.

The Output Value depends on selection of 'Unit Measure'. Refer to [Figure 71](#).

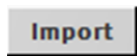
The 'Points' configuration window contains a table with the following data:

Point	Input Value (Ω)	Output Value (°C)
Point 1	0.0	0.0
Point 2	0.0	0.0
Point 3	0.0	0.0
Point 4	0.0	0.0
Point 5	0.0	0.0

Input Value Range: 0 to 300000 Ω

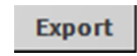
Figure 71: Custom Sensors Points

**Import**



Use this action to share/reuse custom sensor definitions. Custom sensor definitions can be imported from other controllers or stations.

**Export**



This action is used to save the custom sensor in a text file.

	<b>Note:</b> <i>The file must be saved with a .sen extension.</i>
--	--

## Temperature Setpoints



Select 'Temperature Setpoints' from the left pane of the VAV Configuration Wizard. Temperature Setpoints parameters will appear in the right pane as shown in Figure 72.

Temperature Setpoints		
<b>Cooling Setpoints</b>		
Cooling Occupied Setpoint	<input type="text" value="74.0"/>	*F [ 40.0 - 100.0]
Cooling Unoccupied Setpoint	<input type="text" value="85.0"/>	*F [ 40.0 - 100.0]
Cooling Standby Setpoint	<input type="text" value="76.0"/>	*F [ 40.0 - 100.0]
<b>Heating Setpoints</b>		
Heating Occupied Setpoint	<input type="text" value="70.0"/>	*F [ 40.0 - 100.0]
Heating Unoccupied Setpoint	<input type="text" value="60.0"/>	*F [ 40.0 - 100.0]
Heating Standby Setpoint	<input type="text" value="67.0"/>	*F [ 40.0 - 100.0]
Maximum Reheat DAT Setpoint	<input type="text" value="90.0"/>	*F [ 75.0 - 120.0]
<b>Wall Module Setpoints Configuration</b>		
Center Setpoint Low Limit	<input type="text" value="55.0"/>	*F [40.0 - 100.0]
Center Setpoint High Limit	<input type="text" value="85.0"/>	*F [40.0 - 100.0]
<b>DLC and Setpoint Recovery</b>		
Demand Limit Control Setpoint Bump	<input type="text" value="3.0"/>	Δ°F [ 0.0 - 10.0]
<b>SetPoint Ramp</b>		
Minimum Cooling Setpoint Ramp	<input type="text" value="2.00"/>	*F/hr [ 0.0 - 36.0]
Maximum Cooling Setpoint Ramp	<input type="text" value="6.00"/>	*F/hr [ 0.0 - 36.0]
Minimum Heating Setpoint Ramp	<input type="text" value="2.00"/>	*F/hr [ 0.0 - 36.0]
Maximum Heating Setpoint Ramp	<input type="text" value="8.00"/>	*F/hr [ 0.0 - 36.0]
<b>OAT Ramp</b>		
OAT at Minimum Cooling Ramp	<input type="text" value="90.0"/>	*F [ -30.0 - 120.0]
OAT at Maximum Cooling Ramp	<input type="text" value="70.0"/>	*F [ -30.0 - 120.0]
OAT at Minimum Heating Ramp	<input type="text" value="0.0"/>	*F [ -30.0 - 120.0]
OAT at Maximum Heating Ramp	<input type="text" value="60.0"/>	*F [ -30.0 - 120.0]
<b>Occupancy Setpoint Limits</b>		
Low Limit for Occ Heating Stpt	<input type="text" value="0.0"/>	*F [ 0.0 - 100.0]
High Limit for Occ Cooling Stpt	<input type="text" value="100.0"/>	*F [ 0.0 - 100.0]
Space Freeze Protection Setpoint	<input type="text" value="46.4"/>	*F [ -30.0 - 70.0]
Use Wall Module Setpoint for Occupied Mode	Ignore Wall Module Setpoint	
<b>Space Temp Alarm</b>		
Space Temp Alarm High Limit	<input type="text" value="90.0"/>	*F [ 40.0 - 100.0]
Space Temp Alarm Low Limit	<input type="text" value="50.0"/>	*F [ 40.0 - 100.0]
Space Temp Alarm Disable Delay	<input type="text" value="30"/>	min [ 0 - 546]
<b>Unoccupied Heat &lt; Standby Heat &lt; Occupied Heat &lt; Occupied Cool &lt; Standby Cool &lt; Unoccupied Cool</b>		

Figure 72: Temperature Setpoints

Various Control Settings are available as seen in [Figure 72](#) get enabled or disabled based upon previous settings done in Configuration, Inputs, and Outputs screens.

## Cooling Setpoints

Cooling Setpoints		
Cooling Occupied Setpoint	<input type="text" value="74.0"/>	*F [40.0-100.0]
Cooling Unoccupied Setpoint	<input type="text" value="85.0"/>	*F [40.0-100.0]
Cooling Standby Setpoint	<input type="text" value="76.0"/>	*F [40.0-100.0]

### Cooling Occupied Setpoint

It is a setpoint for cooling in an Occupied Mode. Enter the value within the range of 40 °F to 100 °F  
When Effective Occupancy Mode is Occupied and Effective Temperature Mode is 'Cooling Mode', cooling final control element is modulated to maintain this setpoint.

### Cooling Unoccupied Setpoint

It is a setpoint for cooling in Unoccupied Mode. Enter the value within the range of 40 °F to 100 °F  
When Effective Occupancy Mode is Unoccupied and Effective Temperature Mode is 'Cooling Mode', cooling final control element is modulated to maintain this setpoint.

### Cooling Standby Setpoint

It is a setpoint for cooling in Standby mode. Enter the value within the range of 40 °F to 100 °F  
When Effective Occupancy Mode is Standby and Effective Temperature Mode is 'Cooling Mode', cooling final control element is modulated to maintain this setpoint.

## Heating Setpoints

Heating Setpoints		
Heating Occupied Setpoint	<input type="text" value="70.0"/>	*F [40.0-100.0]
Heating Unoccupied Setpoint	<input type="text" value="60.0"/>	*F [40.0-100.0]
Heating Standby Setpoint	<input type="text" value="67.0"/>	*F [40.0-100.0]
Maximum Reheat DAT Setpoint	<input type="text" value="90.0"/>	*F [75.0-120.0]

### Heating Occupied Setpoint

It is a setpoint for Heating in Occupied mode. Enter the value within the range of 40 °F to 100 °F.  
When Effective Occupancy Mode is Occupied and Effective Temperature Mode is 'Heating Mode', heating final control element is modulated to maintain this setpoint.

### Heating Unoccupied Setpoint

It is a setpoint for Heating in Unoccupied mode. Enter the value within the range of 40 °F to 100 °F.

When Effective Occupancy Mode is Unoccupied and Effective Temperature Mode is 'Heating Mode', heating final control element is modulated to maintain this setpoint.

### Heating Standby Setpoint

It is a setpoint for Heating in Standby mode. Enter the value within the range of 40 °F to 100 °F  
When Effective Occupancy Mode is Standby and Effective Temperature Mode is 'Heating Mode', heating final control element is modulated to maintain this setpoint.

## Wall Module Setpoints Configuration

Wall Module Setpoints are related to Wall Module. This field gets enabled when [Wall Module Type](#) is configured as either 'Conventional Wall module' or 'TR 71/75 Wall module'

Wall Module Setpoints Configuration		
Center Setpoint Low Limit	<input type="text" value="55.0"/>	*F [40.0 - 100.0]
Center Setpoint High Limit	<input type="text" value="85.0"/>	*F [40.0 - 100.0]

Low Limits and High Limits are provided to avoid accidental too low or high Center Setpoint. Too High or low center setpoint will cause lot of energy waste and will maintain the room temperature to uncomfortable level.

### Center Setpoint Low limit

Enter the Center Setpoint Low Limit in this field. User cannot lower the Center Setpoint through wall module below this limit.

### Center Setpoint High Limit

Enter the Center Setpoint High Limit in this field. User cannot increase the Center Setpoint through wall module above this limit.

## DLC and Setpoint Recovery

This feature can be used during peak energy consumption.  
When VAV is in Demand Limit Control Mode, the zone setpoints are relaxed by a Demand Limit Control Shift Differential Setpoint in order to reduce energy consumption.

DLC and Setpoint Recovery		
Demand Limit Control Setpoint Bump	<input type="text" value="3.0"/>	ΔF [0.0-10.0]

### Demand Limit Control Setpoint Bump

The Demand Limit Control Setpoint Bump can be set within the range of 0 Δ°F to 10 Δ°F.  
Demand Limit Control Mode is initiated through a Network parameter Demand Limit Control State.

## SetPoint Ramp

The Ramp Rate decides the rate at which the setpoint will transition from current state setpoint to Occupied Setpoint.

### SetPoint Ramp

Minimum Cooling Setpoint Ramp	<input type="text" value="2.00"/>	*F/hr [0.0 - 36.0]
Maximum Cooling Setpoint Ramp	<input type="text" value="6.00"/>	*F/hr [0.0 - 36.0]
Minimum Heating Setpoint Ramp	<input type="text" value="2.00"/>	*F/hr [0.0 - 36.0]
Maximum Heating Setpoint Ramp	<input type="text" value="8.00"/>	*F/hr [0.0 - 36.0]

### Minimum Cooling Setpoint Ramp

It is a minimum rate at which Cooling Setpoint will be achieved.

This rate can be set within the range of 0 °F/hr to 20 °F/hr.

### Maximum Cooling Setpoint Ramp

It is a maximum rate at which Cooling Setpoint will be achieved.

This rate can be set within the range of 0 °F/hr to 20 °F/hr.

### Minimum Heating Setpoint Ramp

It is a minimum rate at which heating Setpoint will be achieved.

This rate can be set within the range of 0 °F/hr to 36 °F/hr.

### Maximum Heating Setpoint Ramp

It is a maximum rate at which Heating Setpoint will be achieved.

This rate can be set within the range of 0 °F/hr to 36 °F/hr.

## OAT Ramp

Since the ramp rates are determined based on outdoor air condition, the limits for OAT are required for Cooling and Heating ramp.

### OAT Ramp

OAT at Minimum Cooling Ramp	<input type="text" value="90.0"/>	*F [-30.0 - 120.0]
OAT at Maximum Cooling Ramp	<input type="text" value="70.0"/>	*F [-30.0 - 120.0]
OAT at Minimum Heating Ramp	<input type="text" value="0.0"/>	*F [-30.0 - 120.0]
OAT at Maximum Heating Ramp	<input type="text" value="60.0"/>	*F [-30.0 - 120.0]

### OAT at Minimum Cooling Ramp


At this outside air temperature, Minimum Cooling Ramp will be applied.

OAT for Minimum Cooling Ramp can be set within the limit of -30 °F to 120 °F.

### OAT at Maximum Cooling Ramp

At this outside air temperature, Maximum Cooling Ramp will be applied.

OAT for Maximum Cooling Ramp can be set within the limit of -30 °F to 120 °F.

	<b>Note:</b>
As OAT varies from OAT at Maximum Cooling Ramp to OAT at Minimum Cooling Ramp, Cooling Ramp Rate varies from Minimum Cooling Ramp Rate to Maximum Cooling Ramp Rate.	

### OAT at Minimum Heating Ramp


At this outside air temperature, Minimum Heating Ramp will be applied.

OAT for Minimum Heating Ramp can be set within the limit of -30 °F to 120 °F.

### OAT at Maximum Heating Ramp

At this outside air temperature, Maximum Heating Ramp will be applied.

OAT for Maximum Heating Ramp can be set within the limit of -30 °F to 120 °F.

	<b>Note:</b>
As OAT varies from OAT at Minimum Heating Ramp to OAT at Maximum Heating Ramp, Heating Ramp Rate varies from Minimum Heating Ramp Rate to Maximum Heating Ramp Rate.	

## Occupancy Setpoint Limits

### Occupancy Setpoint Limits

Low Limit for Occ Heating Stpt	<input type="text" value="0.0"/>	*F [0.0 - 100.0]
High Limit for Occ Cooling Stpt	<input type="text" value="100.0"/>	*F [0.0 - 100.0]
Space Freeze Protection Setpoint	<input type="text" value="46.4"/>	*F [-30.0 - 70.0]
Use Wall Module Setpoint for Occupied Mode	<input type="button" value="Ignore Wall Module Setpoint"/>	

### Low Limit for Occ Heating Stpt

Low Limit for Heating Setpoint in occupied mode is within the range of 0 °F to High Limit for Heating Setpoint in Occupied mode.

User cannot lower the Occupied Heating Setpoint below this limit.

### High Limit for Occ Heating Stpt

Low Limit for Heating Setpoint in occupied mode is within the range of Low Limit for Heating Setpoint in Occupied mode to 100 °F.

User cannot increase the Occupied Heating Setpoint above this limit.

### Space Freeze Protection Setpoint

For Freeze Protection Mode, an **Inputs** is required to configure.

Enter a required setpoint within the range of 30 °F to 70 °F. When window is opened (sensed by the window switch) system switches into Freeze Protection Mode. In this mode, space temperature is maintained to Freeze Protection Setpoint.

Cooling is disabled in this mode.


### Use Wall Module Setpoint for Occupied Mode

This field can be used to configure the wall module setpoint input needs to be utilized or ignored as per the user's preference.



**Ignore Wall Module Setpoint :** If this option is selected, Wall Module Center setpoint is ignored from the calculation of Effective Occupied and Standby Setpoints. Effective Occupied Setpoints are the setpoints set in Temperature Setpoint parameters.

**Use Wall Module Setpoint :** If this option is selected, then Wall Module Setpoint plays role in the calculation of Effective Occupied and Standby Setpoints. Effective Occupied and Standby Setpoints are altered when Wall Module Center Setpoint is changed.

	<b>Note:</b>
<p><i>The Wall Module setpoint is active only when the effective occupancy is Occupied or Bypass.</i></p>	

### Space Temp Alarm

During Occupied mode, if space temperature crosses the high limit or low limit, an alarm will be generated after an alarm delay

<b>Space Temp Alarm</b>	
Space Temp Alarm High Limit	90.0 °F [40.0 - 100.0]
Space Temp Alarm Low Limit	50.0 °F [40.0 - 100.0]
Space Temp Alarm Disable Delay	30 min [0 - 546]

### Space Temperature Alarm High Limit

If the zone temperature rises above this limit, alarm will be generated after a 'Space Temperature Alarm Disable Delay;

### Space Temperature Alarm Low Limit

If the zone temperature falls below this limit, alarm will be generated after a 'Space Temperature Alarm Disable Delay.

### Space Temperature Disable Delay

This field allows setting a space temp alarm disable delay when a system changes to occupied mode.

## Flow Setpoints



Select 'Flow Setpoints' from the left pane of the VAV Configuration Wizard. Flow Setpoints parameters will appear in the right pane as shown in [Figure 73](#).

Flow Setpoints		
Use Special SI Units	<input type="checkbox"/>	m3/hr
<b>Setpoints</b>		
Minimum Flow Setpoint	<input type="text" value="200"/>	cfm [ 0 - 138850 ]
Maximum Reheat Setpoint	<input type="text" value="300"/>	cfm [ 0 - 138850 ]
Standby Flow Setpoint	<input type="text" value="100"/>	cfm [ 0 - 138850 ]
Maximum Flow Setpoint	<input type="text" value="1000"/>	cfm [ 0 - 138850 ]
Minimum Cooling Flow Setpoint during Unocc Mode	<input type="text" value="0"/>	cfm [ 0 - 138850 ]
Fan Flow Setpoint	<input type="text" value="0.0"/>	% [ 0.0 - 100.0 ]
<b>Duct Area</b>		
Diameter	<input type="text" value="8_In_Round"/>	
Area	<input type="text" value="0.349"/>	ft <sup>2</sup> [ 0.0 - 100.0 ]
<b>CO2 Settings</b>		
Low Room CO2 Level	<input type="text" value="400"/>	ppm [ 300 - 1200 ]
High Room CO2 Level	<input type="text" value="900"/>	ppm [ 300 - 1200 ]
Fraction of maximum air flow	<input type="text" value="0.0"/>	[ 0.0 - 1.0 ]
<b>Others</b>		
Fresh Air Required	<input type="text" value="0"/>	cfm [ 0 - 138850 ]
K Factor	<input type="text" value="1400"/>	[ 1 - 10000 ]
Flow Control Throttling Range	<input type="text" value="180"/>	ft/min [ 0 - 5000 ]
Flow Control Dead Band	<input type="text" value="20"/>	ft/min [ 0 - 5000 ]
Maximum Damper Output Change per Second	<input type="text" value="1.100"/>	% [ 0.0 - 100.0 ]
Minimum Damper Output Change per Second	<input type="text" value="0.110"/>	% [ 0.0 - 100.0 ]
Enable Low Flow Alarm	<input checked="" type="checkbox"/>	
Enable Airflow Filter	<input type="checkbox"/>	
<b>Minimum Flow SetPoint &lt; Reheat SetPoint &lt; Maximum Flow SetPoint</b>		

Figure 73: Flow Setpoints



## Use Special SI Units

Check this field to configure flow setpoints in m<sup>3</sup>/hr. This option is available only when the workbench is configured to use metric unit system.

## Setpoints

### Minimum Flow Setpoint

In this field, a user can set a value for minimum cooling flow setpoint during the occupied mode.

### Maximum Reheat Setpoint

A user can set a value for maximum reheat flow setpoint in this field.

### Standby Flow Setpoint

In this field, a user can set a value for minimum flow setpoint during the standby mode.

### Maximum Flow Setpoint

A user can set a value for maximum cooling flow setpoint in this field.

### Minimum Cooling Flow Setpoint during Unocc Mode

In this field, a user can set a value for minimum cooling flow setpoint during the unoccupied mode.

### Fan Flow Setpoint

During the occupied mode, the fan starts when the primary air as a percent of maxflow is less than or equal to Fan Flow percentage set by user in this field.

## Duct Area

### Diameter

It is the area of the cooling duct where the flow sensor is installed.

Required diameter can be selected from available options and duct area is calculated automatically.

A user can select Custom\_Area and enter a specific value in the Area field.

### Area

This field shows the values for duct area in square feet. This value is calculated automatically as per the selection in Diameter field except Custom\_Area. A user can enter a specific value in this field if the diameter is selected as 'Custom\_Area'.

## CO2 Settings

This field gets enabled when 'Space CO2' sensor is configured in the Inputs.

CO2 Settings	
Low Room CO2 Level	400 ppm [ 300 - 1200 ]
High Room CO2 Level	900 ppm [ 300 - 1200 ]
Fraction of maximum air flow	0.0 [ 0.0 - 1.0 ]

### Low Room CO2 Level

This is Low Room CO2 level associated with the minimum flow setpoint.

### High Room CO2 Level

This is High Room CO2 level associated with the highest flow reset. When room CO2 levels vary between the configured low and high CO2 level, the minimum airflow is adjusted proportionally.

### Fraction of maximum airflow

This is the fraction of maximum airflow added to the minimum airflow setpoint while coordinating CO2 with the effective airflow setpoint.

Set this value to zero to disable CO2 ventilation.

## Others


### Fresh Air Required

This is the amount of fresh air required for this zone during scheduled occupancy. A user can enter the amount within the range of 0 – 138850 cfm.

This option is enabled only if Pressure Independent type is configured.

### K factor

This is the VAV Box K-factor used to calculate the flow value.

	<b>Note:</b>
	<ol style="list-style-type: none"> <li>1. The K factor must be configured before starting the airflow balancing procedure.</li> <li>2. The K factor must be obtained from spec sheet of the terminal box manufacturer. If this is not known, set the value to 1400.</li> <li>3. Do not change the K value after the VAV box is balanced.</li> <li>4. Never set the K value to invalid or zero.</li> </ol>

**Flow Control Throttling Range**

A user can select the flow control throttling range within 0-5000 FPM.

**Flow Control Dead Band**

A user can configure the flow control dead band based on the damper motor speed.

**For floating actuators:**


Motor Speed (sec)	Deadband (fpm)
15	125
30	65
60	30
90 to 420	20


**For proportional actuators;**

Motor Speed (sec)	Deadband (fpm)
ML7174	460
ML7287	260
ML7475	330
MN7505 or MN7510	45

**Enable Airflow Filter**

Enable this option if user wants to filter the air flowing inside the zone.

	<b>Note:</b>
<i>The Flow Control Dead Band should be set to 30 fpm when the airflow filter is enabled.</i>	

	<b>Note:</b>
<ol style="list-style-type: none"> <li>1. <i>Proportional actuators are not recommended for pressure independent airflow control.</i></li> <li>2. <i>Set the Flow Control Dead Band to 30fpm when the airflow filter is enabled.</i></li> </ol>	

**Maximum Damper Output Change per second**

The flow control maximum analog output change per second. User should configure this parameter based on the damper motor speed.

Motor Speed (sec)	Deadband (fpm)
15 to 90	1.1
180	0.56
420	330

**Minimum Damper Output Change per Second**

This is the minimum amount the Analog Output will be changed per second for flow control.

**Enable Low Flow Alarm**

Enable this option, if a user wants the controller to track and report low airflow as an alarm.



## Control Parameters

Select 'Control Parameter'  from the left pane of the VAV Configuration Wizard. Control Parameters will appear in the right pane as shown in [Figure 74](#).

Control Parameters		
<b>Flow Control</b>		
Window	<input type="text" value="0.0"/>	% [0.0 - 100.0]
Reheat	<input type="text" value="20.0"/>	% [0.0 - 100.0]
Minimum	<input type="text" value="15.0"/>	% [0.0 - 100.0]
Maximum	<input type="text" value="60.0"/>	% [0.0 - 100.0]
Standby	<input type="text" value="0.0"/>	% [0.0 - 100.0]
Pressurize	<input type="text" value="100.0"/>	% [0.0 - 100.0]
Depressurize	<input type="text" value="0.0"/>	% [0.0 - 100.0]
Emergency Purge	<input type="text" value="50.0"/>	% [0.0 - 100.0]
Night Purge	<input type="text" value="50.0"/>	% [0.0 - 100.0]
Morning Warm-up	<input type="text" value="50.0"/>	% [0.0 - 100.0]
Unoccupied Minimum Flow Position	<input type="text" value="0.0"/>	% [0.0 - 100.0]
<b>Other parameters</b>		
Flow Tracking Offset	<input type="text" value="0.0"/>	cfm [-138850 - 138850]
Morning Warmup Type	<input type="text" value="Warm Air With Reheat"/>	▼
Terminal load calculation	<input type="text" value="Conventional"/>	▼

Figure 74: Control Parameters

## Flow Control

### Window

This is a damper position when window is open. When a window is open, airflow control is disabled and the flow damper is set to this position until the space temperature drops below the temperature setpoint.

### Reheat

This is VAV Box maximum damper position in Reheat mode. The cooling air damper will be set to this position at maximum reheat capacity.

### Minimum

This is a zone terminal minimum cooling damper position during the occupied mode of operation. It is applicable only to a pressure dependent control mode or when a pressure independent airflow sensor fails.

### Maximum

This is VAV Box maximum damper position. It is applicable only to a pressure dependent control mode or when a pressure independent airflow sensor fails.

### Standby

This is VAV Box minimum damper position in Standby mode. It is applicable only to a pressure dependent control mode.

### Pressurize

A user can set a damper position to be used when a Pressurize Command is received over the network for smoke control operation.

### Depressurize

A user can set a damper position to be used when a Depressurize Command is received over the network for smoke control operation.

### Emergency Purge

A user can set a damper position to be used when a Emergency Purge Command is received over the network.

### Night Purge

A user can set a damper position to be used during Night Purge.

### Morning Warmup

A user can set a damper position to be used during Morning Warmup.

## Unoccupied Minimum Flow Position

A user can set a minimum damper position to be used during unoccupied mode.

## Other Parameters

### Flow Tracking Offset

This field represents the flow tracking offset value used when Flow Type is configured as FlowTracking. This offset is added to the value of 'FlowTrackIn (Analog value: 1189)' to determine the flow setpoint.

### Morning Warmup Type

This setting enables a user to select the morning warmup type to be used when the controller receives a 'Morning Warmup' command.

#### Morning Warmup Type

A dropdown menu with a downward arrow on the right. The menu is open, showing four options: 'Mixed Air' (selected), 'Warm Air With Reheat', 'Warm Air Without Reheat', and 'Mixed Air'.

**Warm Air With Reheat:** When this option is selected, Warm air is being supplied via the duct and the temperature control is reversed. Reheat and peripheral may be turned on.

**Warm Air Without Reheat:** When this option is selected, warm air is being supplied via the duct and the temperature control is reversed. Reheat is disabled however, peripheral heat may be used.

**Mixed Air:** When this option is selected, the temperature control is turned off, and the damper is controlled as per the Warmup setting

### Terminal load calculation

This setting' allows user to perform the terminal load calculation.

#### Terminal load calculation

A dropdown menu with a downward arrow on the right. The menu is open, showing three options: 'CZS' (selected), 'Conventional', and 'CZS'.

**Conventional:** The conventional zone terminal load calculation uses the PID output of heating and cooling controls

**CZS:** The CZS zone terminal load calculation uses the proportional output of heating and cooling controls. When the controller is switched to the heating mode, the Terminal Load continues to report both heating and cooling demand.

## Schedule



Select 'Schedule' from the left pane of the VAV Configuration Wizard. Schedule will appear in the right pane as shown in Figure 75.

These parameters are used to configure the schedule events and holidays to be used by the AscBACnetVAV device.

Figure 75: Schedule

Schedule events can be configured in the 'Schedule' tab and Holidays can be configured with the help of parameters in 'Holiday' tab.

	<b>Note:</b>
<p><i>If Schedule parameters are communicated over BACNET Network from another device, then this internally configured schedule will be ignored, as priority will be given to the Schedule received over BACNET Network.</i></p>	

## Schedule

### Local Schedule Type

Local schedule type allows to select the schedule, which can be applied as a default schedule (occupied/unoccupied) for days and holidays. It also allows to customize the schedule as per requirements.

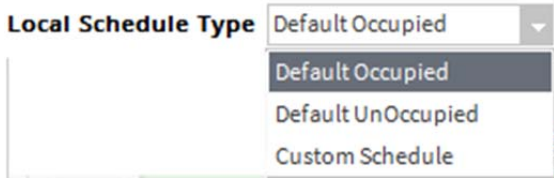


Figure 76: local Schedule type

### Default occupied

If 'Default Occupied option is selected, then Occupied Mode is selected throughout a day for a whole week as shown in [Figure 77](#).

VAV controller will remain in this mode unless it is overridden by any external command.

### Default Unoccupied

If 'Default Unoccupied option is selected, then Unoccupied Mode is selected throughout a day for a whole week as shown in [Figure 78](#).

VAV controller will remain in this mode unless it is overridden by any external command.

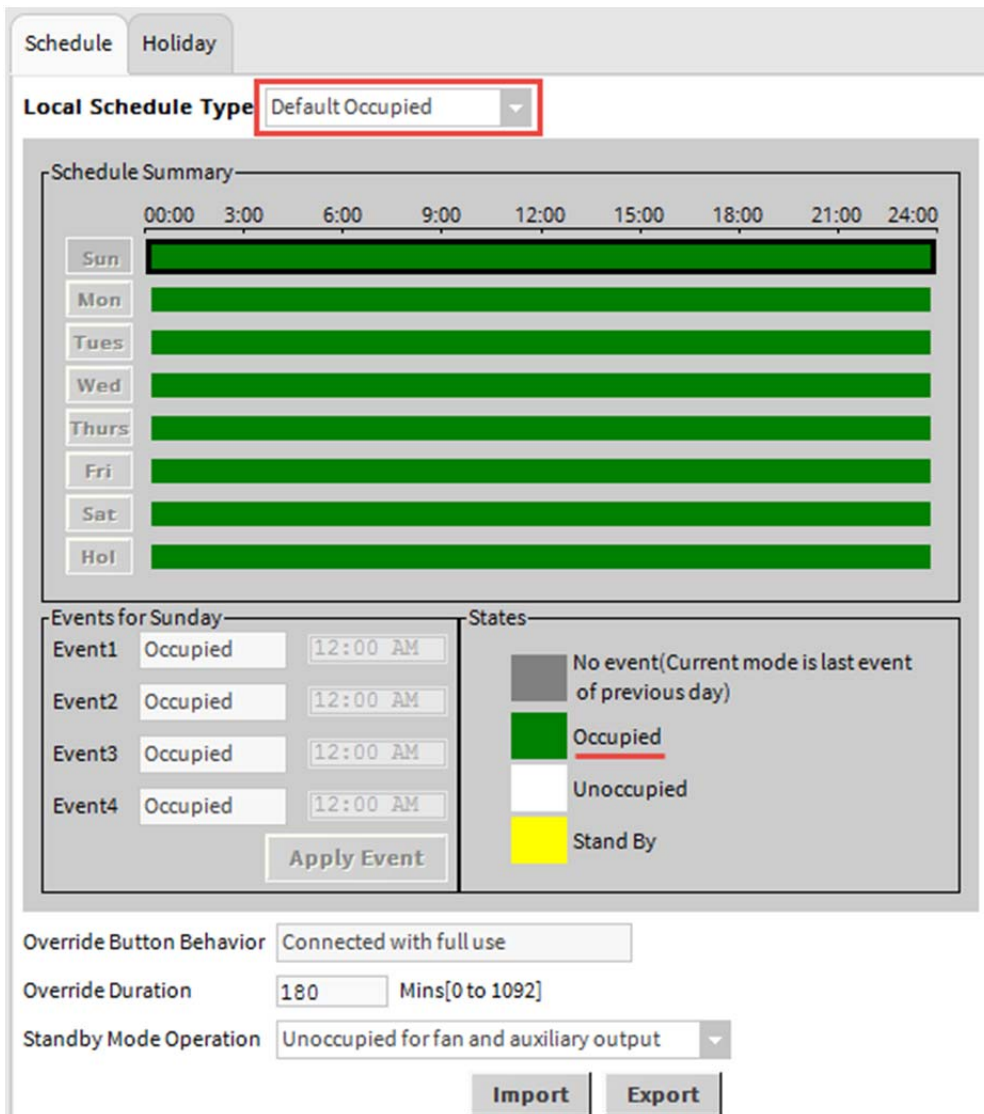


Figure 77: Schedule Type: Default Occupied

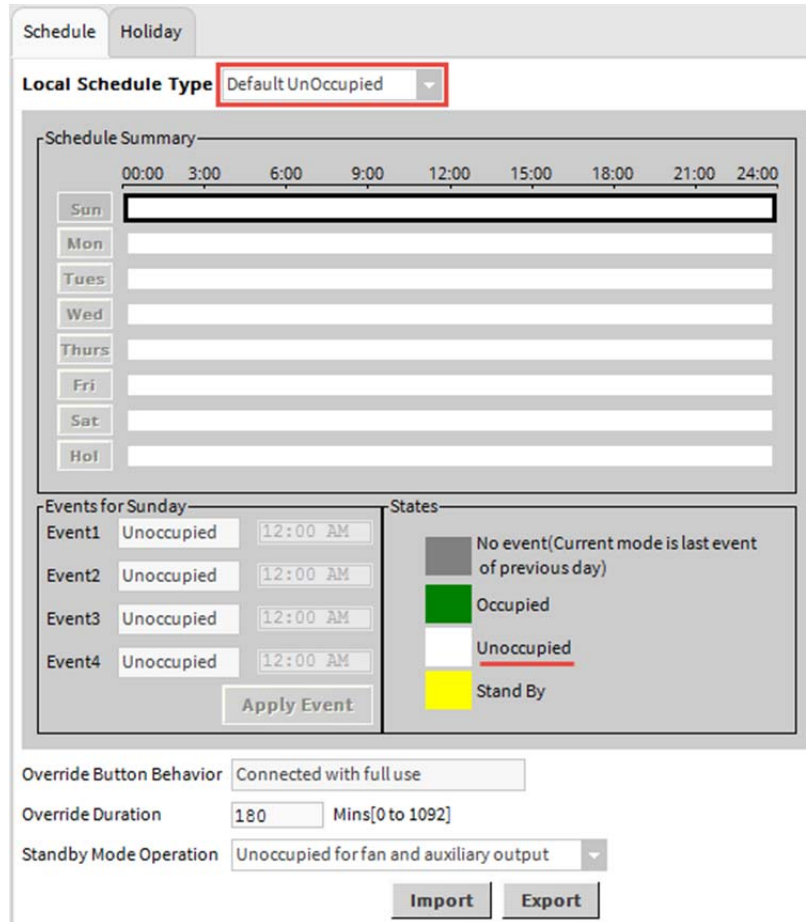


Figure 78: Schedule Type: Default Unoccupied

**Custom Schedule**

Select this option if it more than one mode is required to configure. In custom schedule, a day can be scheduled with multiple events such as, Occupied, Unoccupied, Standby and Bypass.

Four different events with their time period can be scheduled for a day. Refer to [Figure 79](#).

After selecting events and time, click on 'Apply Event' to apply this schedule to that day.

In this case, 'Monday' is scheduled, as shown in [Figure 80](#).

Similarly, rest of the days can be scheduled. If a same schedule is, require for another day, it can be copied.

A holiday can also be customized in this way.

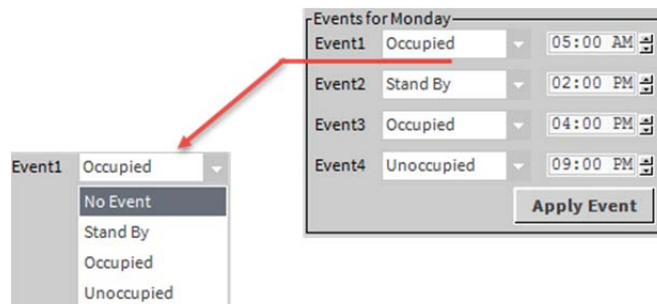


Figure 79: Scheduling an Event

The scheduled events execute in the order based on the time of a day. It is not necessary for the events to be in time sequential order. If the events are entered non-sequentially, the event which is executed earliest, and the next earliest and so on.

If an event state is not programmed (unconfigured), the event time can be anything and will not be used

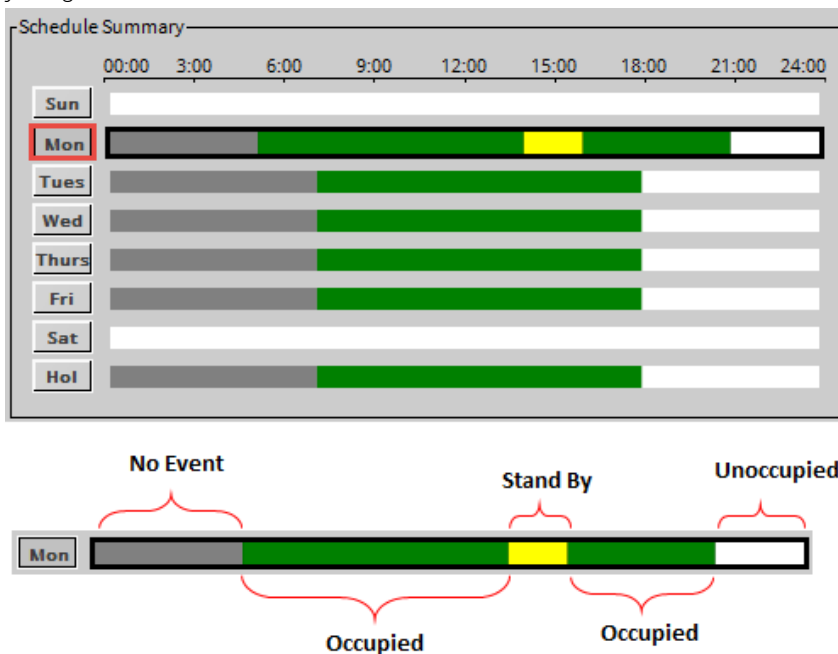


Figure 80: Custom Schedule

**Override Button Behavior**

This field is enabled only when the 'Wall Module Type' is selected as 'Conventional Wall module'.

Conventional wall modules such as TR23 has Override button on the thermostat, which is wired to the digital input of the VAV controller, and user can press this button to override the occupancy.

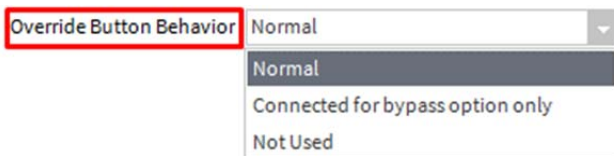


Figure 81: Override Button Behavior

**Connected with full use**

If this option is selected, then unit can be overridden in Bypass as well as in Unoccupied Mode by pressing override button available on the Conventional Wall module selected.

If the unit is overridden to Unoccupied Mode, press the override button again to remove this override.

If the unit is overridden to Bypass mode, press the override button to remove this override or wait until bypass time expires. When bypass time expires, the unit will automatically remove the Bypass override.

**Connected for bypass option only**

If this option is selected, only Bypass Mode can be overridden. Press the override button until LED turns ON. At this moment, the unit is overridden to Bypass Mode. Either wait until bypass time expires or press the override button again until LED turns OFF to remove the Bypass Override state.

**Not Used**

If this option is selected, Occupancy Mode will not be Overridden by Wall Module's override button.

**Override Duration**

Unit will remain in Bypass Mode in for this time duration, when it is overridden to Bypass Mode.

Override Duration can be skipped by pressing the Override button again.

**Standby Mode Operation**

Standby Mode Operation

**Unoccupied for fan and auxiliary output**

When this option is selected, fan and auxiliary output will operate as in Unoccupied Mode during Effective Standby Mode.

**Occupied for fan and auxiliary output**

When this option is selected, fan and auxiliary output will operate as in Occupied Mode during Effective Standby Mode.

**Holiday**

Figure 82: Holiday

Holiday tab is used to select the days and number of holidays to schedule.

**Holiday Type**

There are two types of holidays, Weekday/Month every year and Specific date every year

Figure 83: Holiday Type

**Configure Holiday**

Depending upon the Holiday Type selected, it can be configured by setting months, weekdays, date and total

duration of days. Refer to [Figure 84](#).



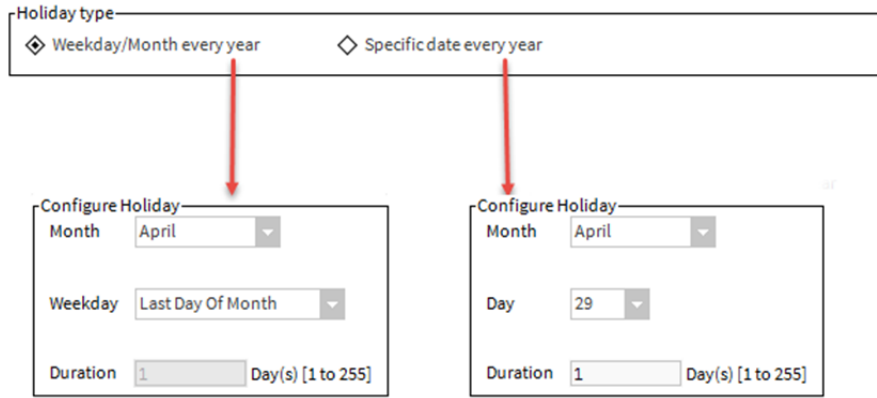


Figure 84: Holiday Type

**Holiday List**

Holiday list displays the list of holidays after configuration.

After configuring the holidays, press 'Add' button to add that holiday in Holiday list. (Refer to [Figure 85](#).)

The lists of some preconfigured holidays (US holidays, Canadian holiday and European holidays) are provided. These can be added in the holidays with the configured holidays as shown in [Figure 85](#).

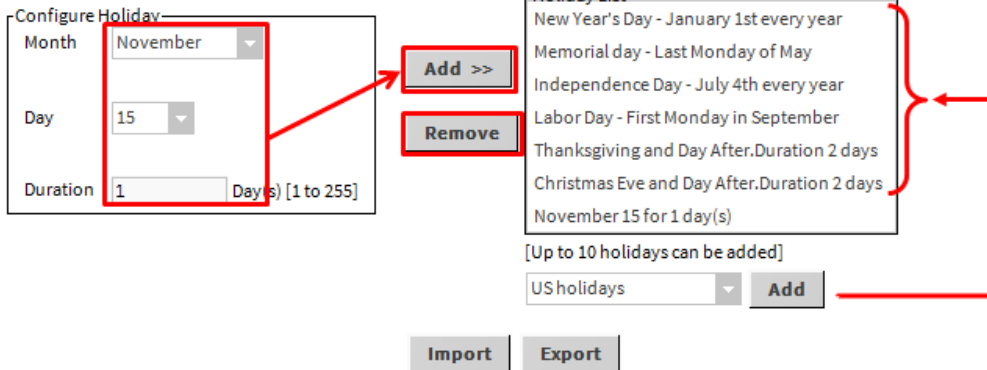


Figure 85: Holiday List

If a holiday is not required from the holiday list, select it and click 'Remove' button.

	<b>Note:</b>
<p><i>If there are few custom holidays already configured, either the US or Canadian or European Holidays option will not load all the holidays if they would exceed the maximum holiday count. For example, if there are more than three holidays already configured, the Load US holidays option will not load all the seven holidays. The first few US holidays are loaded until the total count has reached the maximum of 10 holidays. No duplicate holidays are allowed.</i></p>	

**Import**

It enables to import the holiday settings from an external file.

**Export**

**Export**

It enables to save the holiday settings in an external file.

**Import**



# PID



Select PID from the left pane of the VAV Configuration Wizard  
 These PID settings are for zone heating and cooling PID loop These PIDs modulates heating and cooling final control elements.

PID
?

**Cooling**

Cooling Throttling Range  Δ°F [ 2.0 - 30.0 ]

Cooling Integral Time  s [ 0 - 9000 ]

Cooling Derivative Time  s [ 0 - 9000 ]

**Heating**

Heating Throttling Range  Δ°F [ 2.0 - 30.0 ]

Heating Integral Time  s [ 0 - 5000 ]

Heating Derivative Time  s [ 0 - 9000 ]

Figure 86: PID Settings

Parameters of the PID loop are:

**Throttling Range**

It is the proportional change in the sensed variable. This variable is required to change the control output from 0 % to 100 %. The unit of the throttling range depends upon the unit of process variable.

**Integral Time**

It is used to calculate the integral gain of the PID loop. The time in seconds is inversely proportional to the integral change per second. A setting of 0 eliminates the integral function.

**Derivative Time**

It is used to calculate the derivative gain in a PID loop. The time in seconds is directly proportional to the derivative effect per second. It ranges from 0 sec to 9000 sec.

As per these parameters, output of the PID loop is calculated as follows,

$$\text{Output (\%)} = \text{Bias} + K_p * \text{Err} + K_p/T_i \int_0^t (\text{Err}) dt + K_p * T_d * d\text{Err}/dt$$

Where,

Err = Sensor – Set Point

Tr = Throttling Range

Kp = Controller gain value that should be entered into the controller for good performance

$$K_p = 100/Tr$$

Ti = Integral Time (seconds)

Td = Derivative Time (sec)

Bias = proportional offset (%)

ti = Controller integral setting (minutes per repeat)

td = Controller derivative setting (minutes)

**PID Settings for Cooling**

**Cooling**

Cooling Throttling Range  Δ°F [2.0-30.0]  
 Cooling Integral Time  s [0-9000]  
 Cooling Derivative Time  s [0-9000]

Figure 87: PID Settings for Cooling

Enter the required Throttling Range, Integral Time and Derivative Time in the respective fields.

**Throttling Range** : Value must be within 2 to 30 DDF.

**Integral Time** : Value must be within 0 to 9000 sec.

**Cooling Derivative Time** : Value must be within 0 to 9000 sec.

**PID Settings for Heating**

Throttling Range, integral Time and Derivative Time can be set for cooling loop.

**Heating**

Heating Throttling Range  Δ°F [2.0-30.0]  
 Heating Integral Time  s [0-5000]  
 Heating Derivative Time  s [0-9000]

Figure 88: PID Settings for Cooling

Enter the required Throttling Range, Integral Time and Derivative Time in the respective fields.

**Throttling Range** : Value must be within 2 to 30 DDF.

**Integral Time** : Value must be within 0 to 9000 sec.

**Heating Derivative Time** : Value must be within 0 to 9000 sec.


Throttling Range and Integral Time must be configured based on Reheat configuration by the controller as shown in Table 5

Table 5: Heating PID Parameters

Reheat Type	Throttling Range (TR)	Integral Time (IT)
Modulating	5 Δ°F	2400 sec
1	3 Δ°F	3100 sec
2	4 Δ°F	2500 sec
3	7 Δ°F	1650 sec
4	8 Δ°F	1200 sec

## Accessories Loops

In addition to the conventional/modulating and heat pump applications, VAV controller provides two additional accessory loops. These loops are freely configured to control other equipment's such as exhaust fan, etc.

Select 'Accessory Loops'  from the left pane of the VAV Configuration Wizard. The Loop1 page appears as shown in [Figure 89](#).

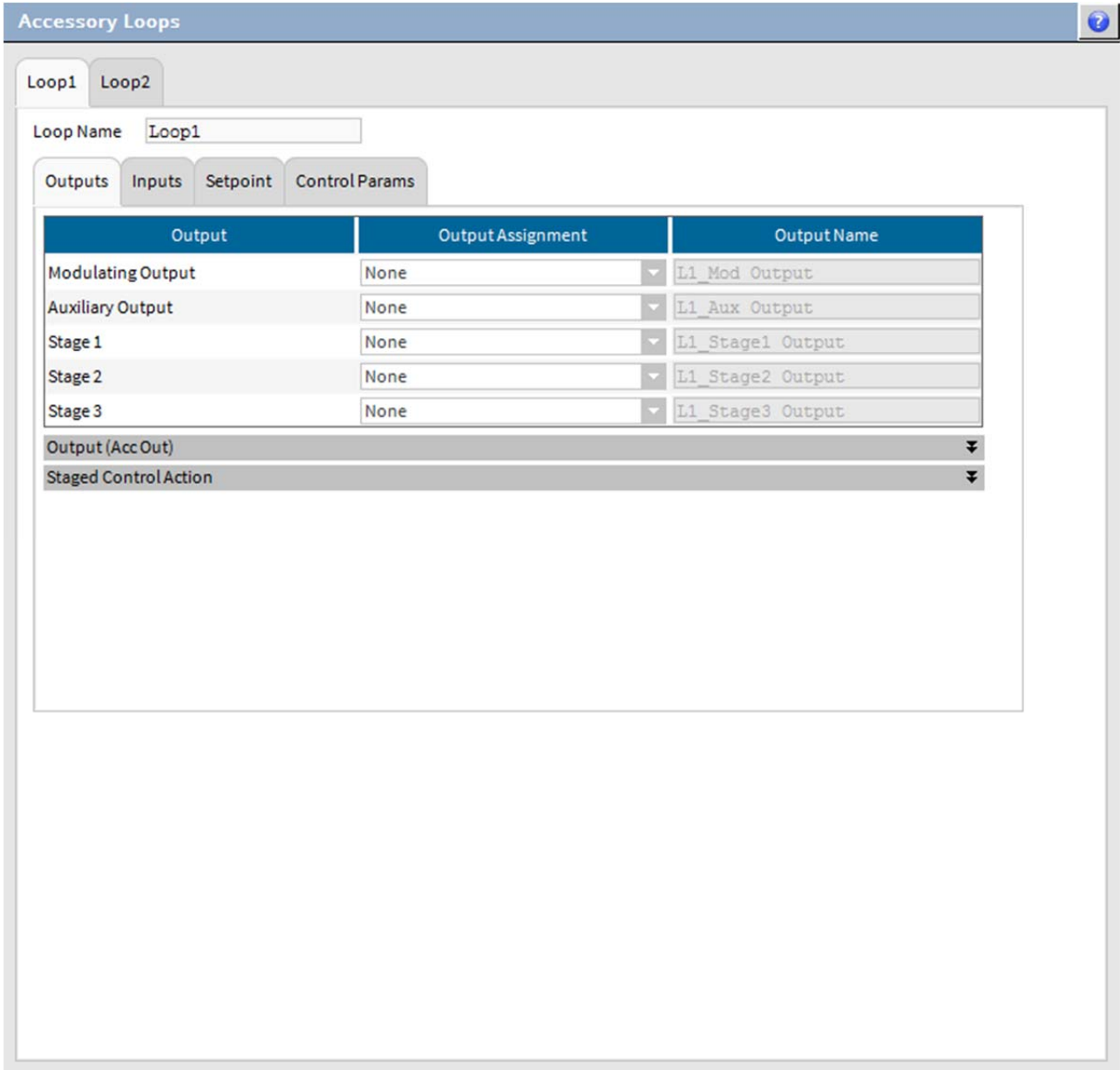


Figure 89: Accessories Loops

- Following are the sub tabs available for accessory loops.
- Output
  - Input
  - Setpoint
  - Control Parameters

## Output

Accessory loop can be configured to drive a modulating output, up to three staged outputs and an auxiliary digital output. The outputs can be configured only when the required pins are available/free.

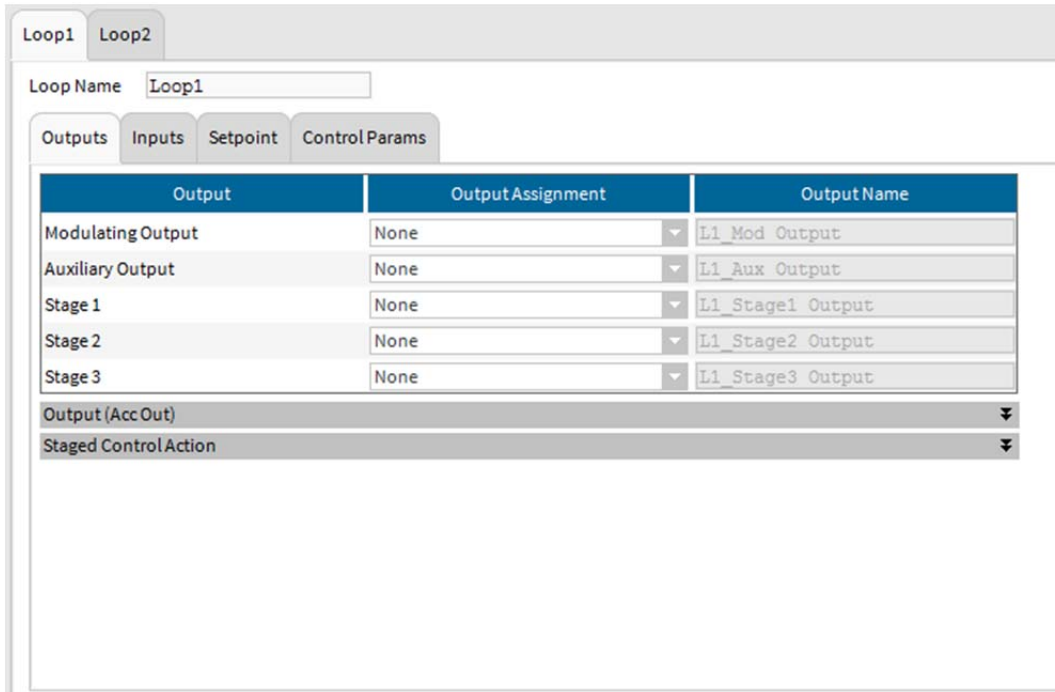


Figure 90: Output for Accessories Loop

### Modulating Output

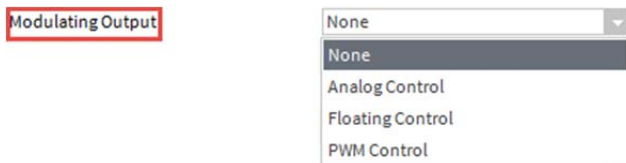


Figure 91: Modulating Output

**None:** If Modulating Output is not required, select this option.

**Analog Control:** If analog type is selected, then the output of the PID loop is assigned to the analog output of the VAV controller. When Analog Control is selected, an 'Output (Acc Out)' tab extends for analog control parameters settings. Refer to [Figure 61](#).

**Floating Control:** If floating type is selected, then the output of the PID loop is assigned to the two digital outputs of the VAV controller. Refer to [Figure 61](#) for more details about Floating Control parameters.

**PWM Control:** This option enables to enter Pulse Width Modulation (PWM) period, zero scale and full scale. When PWM Control is selected, an 'Output (Acc Out)' tab extends for PWM control parameters settings.

### Auxiliary output.

It is a digital output. When configured, its operation depends upon the following parameters.



Figure 92: Auxiliary Output

**None:** If Auxiliary Output is not required, select this option.

**Digital Control:** When this option is selected then auxiliary output gets assigned to the loop. This operation depends upon [Auxiliary Output](#) parameter set. To navigate to these settings, refer to [Control Parameters](#).

## STRYKER VAV CONTROLLER

Up to three staged outputs (Stage 1, Stage 2, and Stage 3) can be assigned to accessory loop.

These staged outputs act as per the staged control actions,

1. Conventional
2. Thermostat 3 Cycles/hr

### Stage 1/Stage 2/Stage 3



Figure 93: Output parameters for Staged Output

**None:** If Staged Output is not required, select this option.

**Digital Control:** If this option is selected, the stage will act as per the 'Staged Control Action', which extends as shown in [Figure 94](#).



Figure 94: Staged control action for Staged output

### Staged Control Action

- **Conventional:** If Staged Control Action is set to 'Conventional', then 'stager behavior' operates these staged outputs.
- **Thermostat 3 Cycles/hr:** If Staged Control Action is set to 'Thermostat 3 Cycles/hr', then the cycler behavior with CPH = 3 and anticipatory authority = 100 % operates these staged outputs.

## Inputs

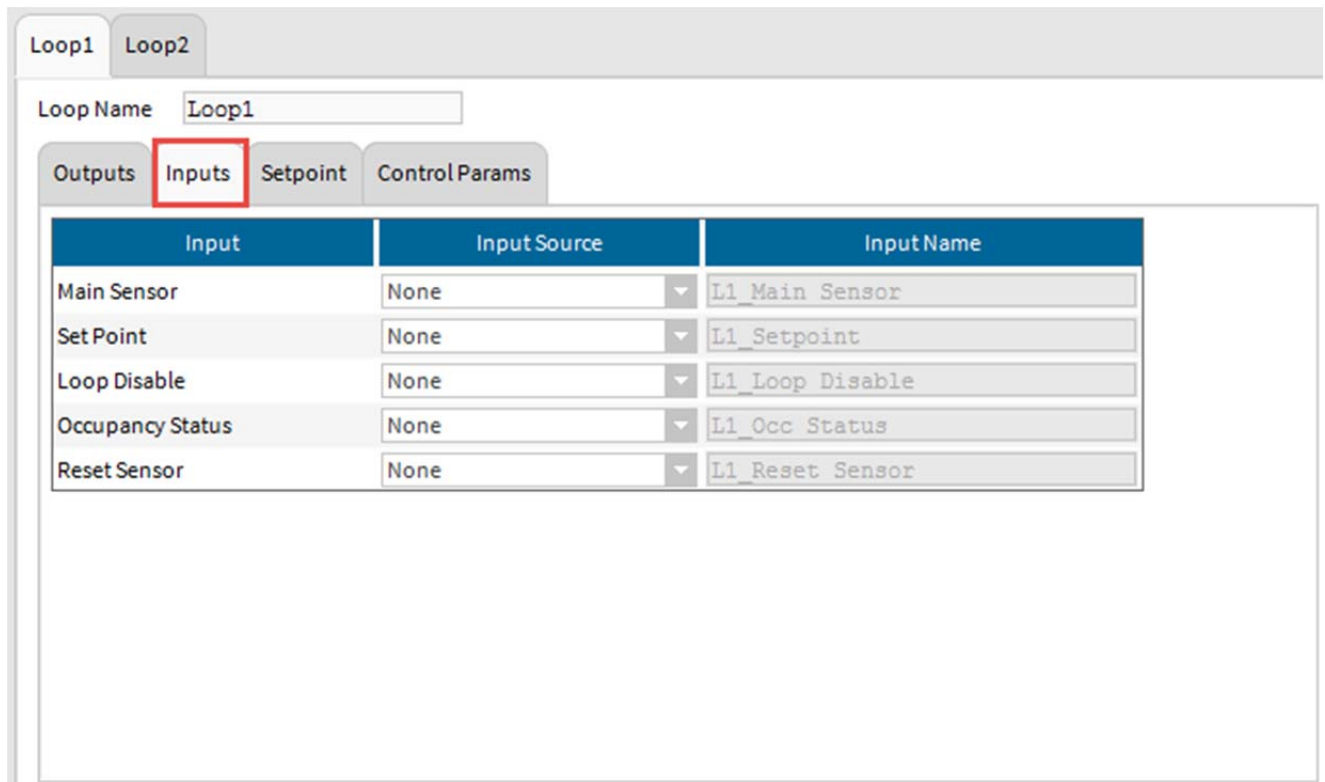


Figure 95: Inputs for Accessories Loop

### Main Sensor

Main sensor acts a process variable for the accessory PID loop. Loop modulates (or operate stages of) final control element to maintain the process variable to the setpoint.

Select the Main sensor from the available sensors in Input Source drop down list.

The available sensors are

- None
- 20 Kntc
- TR2X 20Kntc
- Custom Sensor 1
- Custom Sensor 2
- RH 0 to 10V
- RH 2 to 10V
- CO2 0 to 2000 ppm
- Pressure 0 to 5 inWc
- Pressure 0 to 2.5 inWc
- Pressure 0 to 0.25 inWc
- 0 to 10 V Generic
- C7400\_A\_C
- C7400\_Temp\_8
- C7400\_Temp\_9
- C7400\_Temp\_10
- C7400\_Temp\_11
- C7400\_Temp\_12
- C7400\_RH\_8
- C7400\_RH\_9
- C7400\_RH\_10
- C7400\_RH\_11
- C7400\_RH\_12
- Network Input Free1Mod
- Network Input Free2Mod
- Main Application Output
- Shared input

**Main Application Output:**

If the main sensor is any sensor from the configured analog inputs for the VAV controller, select this option. All selected analog inputs for the controller will appear in input Name drop down menu. Select the one from the available list as per the requirement.

The available options for the controller configured for illustration is,

- Maximum Of Multi-Inputs
- Minimum Of Multi-Inputs
- Average Of Multi-Inputs
- Smart Of Multi-Inputs
- Space Temperature
- Space Humidity
- Mixed Air temperature
- Discharge Air Temperature
- Outdoor Air Temperature
- Return Air Temperature
- Outdoor Air Enthalpy
- Return Air Enthalpy

The above list depends upon inputs configured in the Inputs screen and hence varies from application to application.

Refer to [Figure 96](#) for details.

**Shared Input:**

If the Share Input option is selected in the Input Source then all shared inputs will be available in the Input Name drop down list. Select the one from the list as per the requirement. Shared inputs are inputs, which are used for multiple loops in the same application. Following is the list shown for the configuration utilized for demonstration here. It varies from configuration to configuration.

- Space temp
- Space hum
- Space CO2
- Outdoor temp.

Refer to [Figure 96](#) for details.

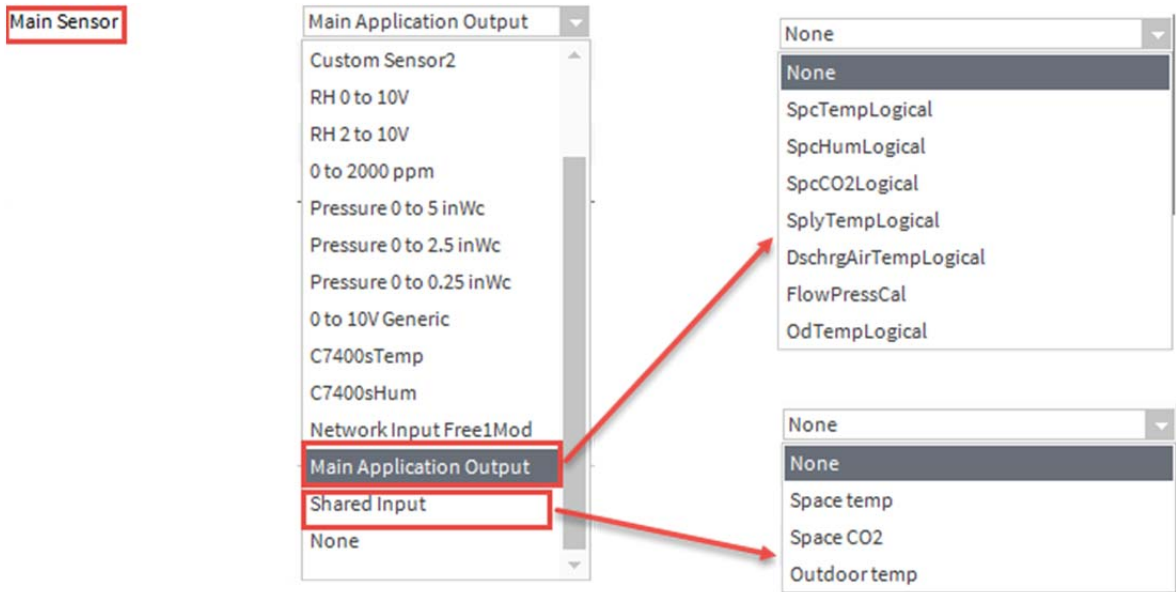


Figure 96: Inputs for Main Sensor

**Set point**

Value of the selected sensor from this field acts as a setpoint for the loop. Final control element is modulated to maintain the process variable (selected Main Sensor) to this setpoint.

Following list of sensors is available in Input Source drop down list. Select the required sensor.

- None
- 20 Kntc
- TR2X 20Kntc
- Custom Sensor 1
- Custom Sensor 2
- RH 0 to 10V
- RH 2 to 10V
- CO<sub>2</sub> 0 to 2000 ppm
- Pressure 0 to 5 inWc
- Pressure 0 to 2.5 inWc
- Pressure 0 to 0.25 inWc
- 0 to 10 V Generic
- C7400\_A\_C
- Main Application Output
- Shared Input

**Main Application Output**

If Main Application Output is selected as Setpoint then all available setpoints available in the main application appears in the drop down list of Input Name. Select the required one from the drop down list.

Following is the list available from the application utilized for demonstration. The list varies from configuration to configuration.

- Heating Setpoint
- Cooling Setpoint
- Wall Module Centre Setpoint

**Shared Input**

If the Share Input option is selected in the Input Source then all shared inputs will be available in the Input Name drop down list. Select the one from the list as per the requirement. Shared inputs are inputs, which are used for multiple loops in the same application. Following is the list shown for the configuration utilized for demonstration here. It varies from configuration to configuration.

- Space temp
- Space hum
- Space CO<sub>2</sub>
- Outdoor temp.

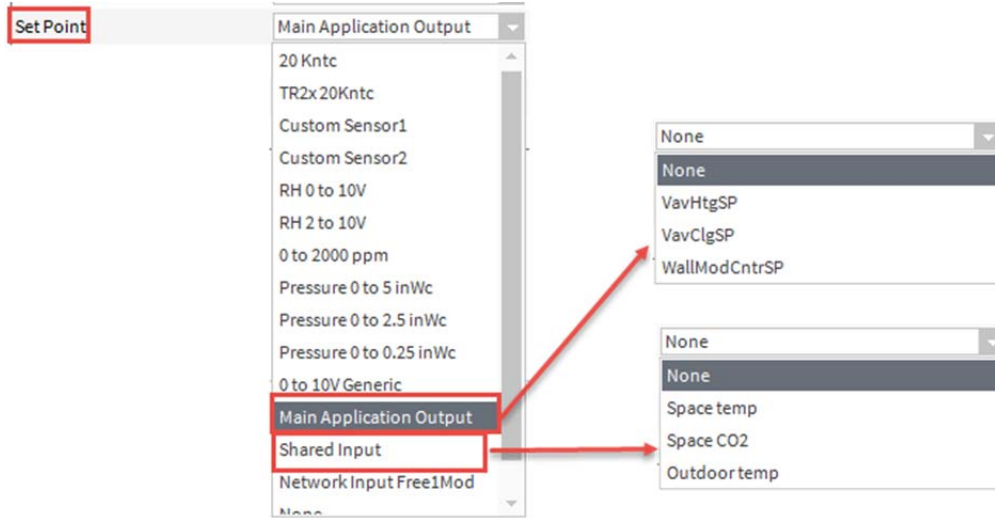


Figure 97: Inputs for Set point

**Loop Disable**

Loop Disable is utilized to disable the loop. When the input is TRUE, the loop is disabled and output of the loop is 0 %. When the input is in FLASE state, loop is enabled and output is according to the error between process variable and setpoint and PID loop parameter settings.

As shown in the figure 137, select the input from the Input Source drop down menu as per the requirement.

**Main Application Output:**

When this option is selected from 'Input Source' drop down list, the outputs configured in the applications will be available to disable the loop in the Input name drop down list.

Following is the drop down list shown from the application utilized for demonstration here. This drop down list is depends upon the outputs of the selected application and varies from configuration to configuration.

**Shared Input:**

If the Share Input option is selected in the Input Source then all shared inputs will be available in the Input Name drop down list. Select the one from the list as per the requirement. Shared inputs are inputs, which are used in the same application for other purpose.

Following is the list shown for the configuration utilized for demonstration here. It varies from configuration to configuration.

- Space temp
- Space hum
- Space CO<sub>2</sub>
- Outdoor temp.

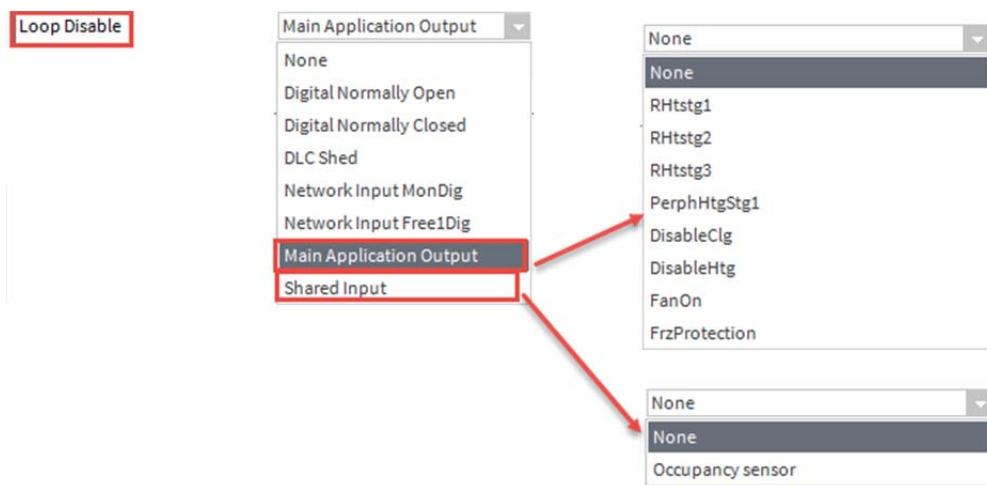


Figure 98: Inputs for Loop Disable



**Occupancy Status**

If the Occupancy Status input is assigned to the loop and Set point input is not configured, then the loop accepts setpoints entered in the 'Set points' parameters list as shown in Figure 99.

**Main Application Output:**

If the Occupancy Status is selected as 'Main Application Output', then user can select occupancy status created in the main applications. Refer to Figure 98.

Shared input: If Occupancy Sensor is selected as 'Shared input' from the 'Input Source' drop down list, then shared inputs from the application will be available in Input Name drop down list. Select the required input Figure 98.

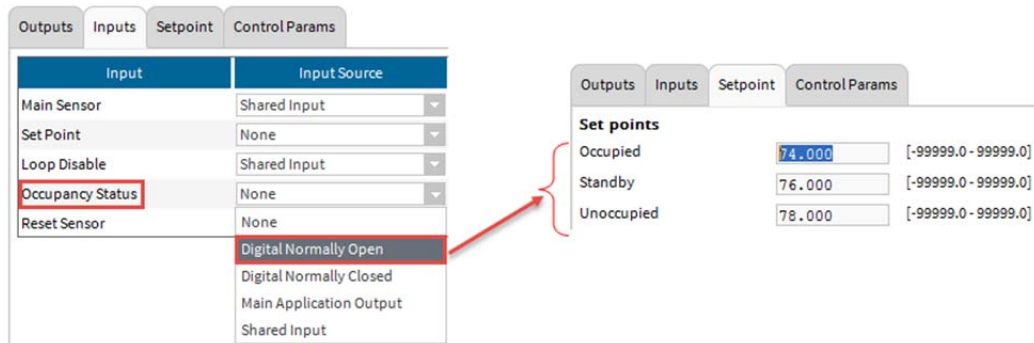


Figure 99: Occupancy Status Setpoints

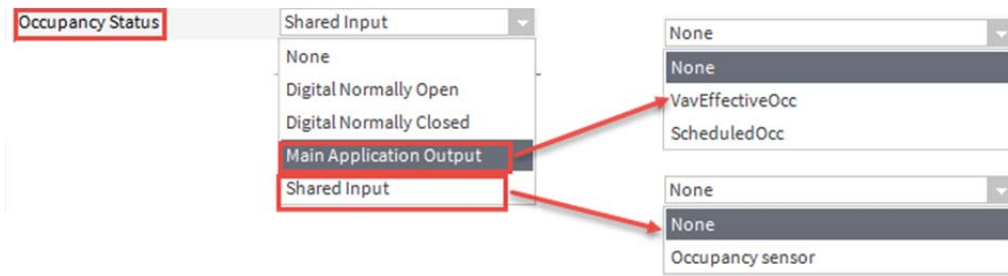


Figure 100: Inputs for Occupancy Status

**Reset Sensor**

Reset Sensor input if selected, resets the setpoint of the loop as per the parameter settings done in Setpoint>Set point Reset parameters. Refer to Figure 101.

Select the required Reset Sensor form the sensors available in the 'Input Source' drop down list. Following is the list of available options for Reset Sensor.

- None
- 20 Kntc
- TR2X 20Kntc
- Custom Sensor 1
- Custom Sensor 2
- RH 0 to 10V
- RH 2 to 10V
- CO2 0 to 2000 ppm
- Pressure 0 to 5 inWc
- Pressure 0 to 2.5 inWc
- Pressure 0 to 0.25 inWc

- 0 to 10 V Generic
- C7400\_A\_C
- Main Application Output
- Shared Input

**Main Application Output:**

If the Occupancy Status is selected as 'Main Application Output', then user can select occupancy status created in the main applications. Refer to Figure 100.

Shared input: If Occupancy Sensor is selected as 'Shared input' from the 'Input Source' drop down list, then shared inputs from the application will be available in Input Name drop down list. Select the required input Figure 100.

**Shared Input:**

If the Share Input option is selected in the Input Source then all shared inputs will be available in the Input Name

drop down list. Select the one from the list as per the requirement. Shared inputs are inputs, which are used in the same application for other purpose.

Following is the list shown for the configuration utilized for demonstration here. It varies from configuration to configuration.

- Space temp
- Space hum
- Space CO<sub>2</sub>
- Outdoor temp.

The screenshot shows a configuration window with tabs for 'Outputs', 'Inputs', 'Setpoint', and 'Control Params'. The 'Inputs' tab is active, displaying a table with columns 'Input' and 'Input Source'. The 'Reset Sensor' row is highlighted with a red box. To the right, the 'Set point Reset' section contains four parameters:

Set point Reset		
Minimum Reset Sensor Value	65.000	[-99999.0 - 99999.0]
Maximum Reset Sensor Value	-10.000	[-99999.0 - 99999.0]
Min Reset Amount	0.000	[-99999.0 - 99999.0]
Max Reset Amount	0.000	[-99999.0 - 99999.0]

Figure 101: Reset Sensor Setpoint

The screenshot shows the 'Reset Sensor' dropdown menu. The 'Reset Sensor' label is highlighted with a red box. The dropdown list includes the following options:

- None
- SpcTempLogical
- SpcHumLogical
- SpcCO2Logical
- SplyTempLogical
- DschrgAirTempLogical
- FlowPressCal
- OdTempLogical
- WallModCntrSP
- Airflow
- DmprPos
- ReheatMod
- PeriphHtgMod
- FanMod
- TerminalLoad
- None
- Space temp
- Space CO2
- Outdoor temp

Figure 102: Inputs for Reset Sensor

## Setpoint

Setpoints provided in this screen are depends upon the settings done in Inputs and Outputs screen of the accessory loops.

The screenshot shows the 'Setpoint' configuration screen for 'Loop1'. It features a 'Loop Name' field set to 'Loop1' and four tabs: 'Outputs', 'Inputs', 'Setpoint', and 'Control Params'. The 'Setpoint' tab is highlighted with a red border. Under the 'Set points' section, there are three rows: 'Occupied' with a value of 74.000, 'Standby' with 76.000, and 'Unoccupied' with 78.000. Each row has a range field set to [-99999.0 - 99999.0]. Below this is the 'Set point Reset' section with four rows: 'Minimum Reset Sensor Value' (65.000), 'Maximum Reset Sensor Value' (-10.000), 'Min Reset Amount' (0.000), and 'Max Reset Amount' (0.000). Each reset field has a range field set to [-99999.0 - 99999.0].

Figure 103: Setpoints

in this field by modulating (or operating stages of) the output.

### Setpoints for occupancy modes

If in the Input section if Occupancy Sensor is configured, then these setpoints are utilized by the loop. Enter the required values in the given fields.

This screenshot shows a section titled 'Set points' with a grey header. Below the header are three rows of input fields. The first row is 'Occupied' with a value of 74.000 and a range of [-99999.0 - 99999.0]. The second row is 'Standby' with a value of 76.000 and a range of [-99999.0 - 99999.0]. The third row is 'Unoccupied' with a value of 78.000 and a range of [-99999.0 - 99999.0].

Figure 104: Setpoints for different occupancy modes

**Occupied:** When the [Occupancy Status](#) is in Occupied Mode and when the accessory loop is not disabled by the Loop Disable, accessory loop maintain the process variable ([Main Sensor](#)) to the Occupied Setpoint specified in this field by modulating (or operating stages of) the output. Refer to [Figure 103](#).

**Standby:** When the [Occupancy Status](#) is in Standby Mode and when the accessory loop is not disabled by the Disable Input, accessory loop maintain the process variable (Main Sensor) to the Standby Setpoint specified

**Unoccupied:** When the [Occupancy Status](#) is in Unoccupied Mode and when the accessory loop is not disabled by the Disable Input, accessory loop maintain the process variable (Main Sensor) to the unoccupied Setpoint specified in this field by modulating (or operating stages of) the output. Refer to [Figure 103](#).

### Set point Reset

If Reset Sensor is configured in the Input screen of the Accessory Loops, then only these parameters are functional. Else, these parameters does not have any effect on the accessory loop.

When Reset Sensor value varies from 'Minimum Reset Value' to 'Maximum Reset Value', the accessory loop setpoint varies from 'Min Rest Amount' to Max Reset Amount'. Refer to [Figure 105](#).

Set point Reset		
Minimum Reset Sensor Value	<input type="text" value="65.000"/>	[-99999.0 - 99999.0]
Maximum Reset Sensor Value	<input type="text" value="-10.000"/>	[-99999.0 - 99999.0]
Min Reset Amount	<input type="text" value="0.000"/>	[-99999.0 - 99999.0]
Max Reset Amount	<input type="text" value="0.000"/>	[-99999.0 - 99999.0]

Figure 105: Setpoint Reset

### Control Parameters

In the control parameter screen of the Accessory Loops, parameters related to .PID loop and Auxiliary Output is provided.

Loop1 Loop2

Loop Name

Outputs Inputs Setpoint Control Params

**Main Control**

Throttling Range  [0.0 - 99999.0]

Integral Time  s [0 - 65553]

Derivative Time  s [0 - 65553]

PID Action

**Auxiliary Output**

AuxDO Action  Continuous For Occupied and Standby only.  
 Intermittent For Occupied, Bypass, Unoccupied and Standby

Modulating Control For Aux  Yes  No

Modulating Output Threshold For Aux  % [0.0 - 200.0]

Aux Output Minimum Off Time  s [0 - (Minimum Off Time - Run On Time)]

Aux Output Run On Time  s [0 - 65553]

**Staged Outputs**

Minimum Off Time  s [0 - 65553]

Cyclers and Stager Interstage Minimum On Time  s [60 - 1200]

**Auxiliary and Staged Outputs**

Minimum On Time  s [0 - 65553]

Figure 106: Inputs for Reset Sensor

**Control Parameters**

Following are the parameters of the PID loop:

**Main Control**

**Main Control**

Throttling Range	<input type="text" value="7.000"/>	[ 0.0 - 99999.0 ]
Integral Time	<input type="text" value="1650"/>	s [ 0 - 65553 ]
Derivative Time	<input type="text" value="0"/>	s [ 0 - 65553 ]
PID Action	<input type="text" value="Direct"/>	

Figure 107: Main Control Parameters

**Throttling Range**

It is the proportional change in the sensed variable. This variable is required to change the control output from 0 % to 100 %. The unit of the throttling range depends upon the unit of process variable.

**Integral Time (Default = 1650 seconds)**

It is used to calculate the integral gain of the PID loop. The time in seconds is inversely proportional to the integral change per second. A setting of 0 eliminates the integral function. It ranges from 0 sec to 5000 sec

**Derivative Time (0 seconds)**

It is used to calculate the derivative gain in a PID loop. The time in seconds is directly proportional to the derivative effect per second. It ranges from 0 sec to 6553 sec.

**Derivative Time:** Determines the derivative gain in a PID loop. The greater the time in seconds, the greater the derivative effect per second.

**PID Action:** Direct Acting or Reverse Acting selection determines the behavior of the loop output.

**PID Action**

<input type="text" value="Direct"/>
<input type="text" value="Direct"/>
<input type="text" value="Reverse"/>

Figure 108: PID Action

**Direct:** Set the PID action as 'Direct' if the loop output increase as the process variable increases. For example, space temperature is maintained by cooling valve. As space temperature increases, cooling valve is need to be modulated open to maintain the space temperature to the setpoint. In this case, PID action is 'Direct'

**Reverse:** Set the PID action as 'Reverse' if the loop output decreases as the process variable increases. For example, space temperature is maintained by heating valve. As space temperature decreases, heating valve is need to be modulated open to maintain the space temperature to the setpoint. In this case, PID action is 'Reverse'.

### Auxiliary Output

Auxiliary digital output turns on when,

1. When the Occupancy Sensor is in Occupied or Standby Mode and Aux Do Action is selected as 'Continuous'.

2. When PID output value exceeds the 'Modulating Output Threshold For Aux' value and 'Modulating Control For Aux' setting is 'Yes'.
3. Accessory loop is enabled and first stage of the accessory loop is turned ON.

These settings are applicable if is configured in the Outputs screen of the Accessory Loops.

OR

**Auxiliary Output**

Aux DO Action

- Continuous For Occupied and Standby only.
- Intermittent For Occupied, Bypass, Unoccupied and Standby

Modulating Control For Aux

- Yes
- No

Modulating Output Threshold For Aux

200.000 % [ 0.0 - 200.0 ]

Aux Output Minimum Off Time

30 s [ 0 - (Minimum Off Time - Run On Time) ]

Aux Output Run On Time

0 s [ 0 - 65533 ]

Figure 109: Auxiliary Output

### Aux DO Action

This determines the Aux DO behavior.

The Aux output can be configured for either continuous or intermittent operation.

- **Continuous:** If this option is selected, then auxiliary output is always on during Occupied Mode and Standby Mode. During Unoccupied Mode and Bypass Mode, auxiliary output is turned ON intermittently.
- **Intermittent:** For all Occupancy Modes (Occupied, Unoccupied, Bypass and Standby), the auxiliary output is turned ON intermittently
- **Modulating Control For Aux**

If this option is selected as 'Yes', it allows the Aux DO to be controlled based on the value of the loops modulating output. It enables the 'Modulating output Threshold for Aux' field editable.

### Modulating Output Threshold For Aux

The accessory loop's output is compared with this setpoint. If the output exceeds this setpoint value, auxiliary digital output turned ON.

### Aux output minimum off time

If auxiliary digital output is commanded OFF, it remains ON for this duration and then turns OFF.

	<b>Note:</b>
<p><i>When staged outputs are configured, this value must be configured to be less than (Cycler and stager interstage minimum on time - Aux output run on time).</i></p>	

### Aux Output Run On Time

It is a minimum time for which an auxiliary DO continues to run in ON state. A value of 0 disables the run-on time. This is typically used when the AuxDo is configured for intermittent operation.

**Staged Outputs**

Staged Outputs		
Minimum Off Time	<input type="text" value="300"/>	s [ 0 - 65553 ]
Cycler and Stager Interstage Minimum On Time	<input type="text" value="60"/>	s [ 60 - 1200 ]

Figure 110: Staged Outputs

**Minimum Off Time**

This is a minimum OFF time for the staged outputs. It can be set within the limit of 0 sec to 65553 sec.

**Cycler and Stager Interstage Minimum On Time**

This is minimum amount of time a lower numbered stage must be on before the next stage can turn on. It can be set within the range of 60 sec to 1200 sec.

**Auxiliary and Staged Outputs**

Auxiliary and Staged Outputs		
Minimum On Time	<input type="text" value="300"/>	s [ 0 - 65553 ]

Figure 111: Auxiliary and Staged Outputs

**Minimum On Time**

It is a minimum On time for Auxiliary DO and Staged Outputs.

## Custom Wiring



Click 'Custom Wiring' in the left pane. It displays a 'Custom Wiring' screen in right pane.

After completion of the VAV configuration, selected inputs and outputs are automatically get assigned to the VAV controller's input and output terminals.

However, user can change the inputs and outputs terminal assignment as per the preference. Input and output terminal assignment is flexible.

The screenshot shows the 'Custom Wiring' window with a central table of terminal assignments. On the left, there are dropdown menus for selecting devices, and on the right, there are dropdown menus for selecting terminal types. At the bottom, there are two buttons: 'Terminal Overlay Diagram' and 'Wiring Diagram'.

Occupancy sensor	UI-1*	DO-4	Damper motor-CLOSE
--Unassigned--	COM	COM	
--Unassigned--	UI-2	DO-3	Damper motor-OPEN
	UI-3	SHIELD	
Space CO2	COM	BAC-	
Reheat	UI-4	BAC+	
	AO-1	SBUS2	
--Unassigned--	COM	SBUS1	
Peripheral heating	AO-2	20Vdc	
	DO-1	EGND	
	COM	24VAC COM	
Loop1-L1_AuxOutput	DO-2	24VAC	

Figure 112: Input/output Terminal Assignments on VAV Controller



**Universal Input (UI) Terminals**

Depending upon the configuration for [Inputs](#), connections can be made with four available UI terminals.

**Analog Output (AO) Terminals**

Depending upon the configuration for Analog Outputs in [VAV Outputs](#) and [Modulating Output](#), connections can be made with two available AO terminals

**Digital Output (DO) Terminals**

Depending upon the [CONFIGURATION](#) for Digital Outputs in [VAV Outputs](#) and [Modulating Output](#), connections can be made with four available DO terminals.

**Terminal Overlay Diagram**

**Terminal Overlay Diagram**

Click 'Terminal Overlay Diagram' button to generate the terminal overlay diagram as shown in [Figure 113](#).

This allows you to print the Terminal Overlay to use it on the relevant controller.

	<b>Note:</b>
<p>The terminal overlay diagram is formatted to match the size of the terminal overlay present on the controller. Only 6 characters will be displayed in the generated terminal overlay diagram.</p>	

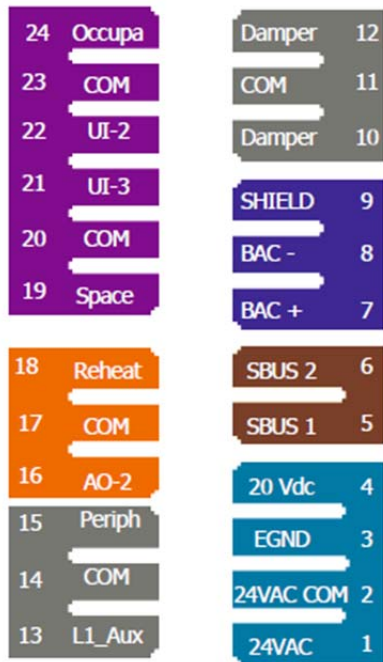


Figure 113: Overlay Diagram for Stryker VAV

**Wiring Diagram**

**Wiring Diagram**

Click 'Wiring Diagram' button to see the wiring between inputs and outputs.

As shown in [Figure 114](#), this wiring diagram shows how a controller is connected with the configured external inputs and outputs.

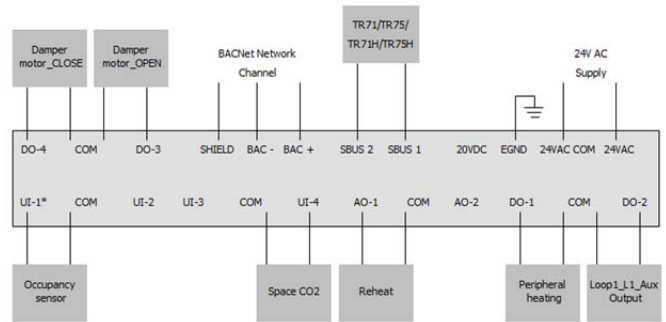


Figure 114: Wiring Diagram for Stryker VAV

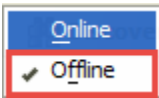
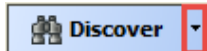
## OFFLINE POINT DISCOVERY

For the BACnet Network, the points can be discovered online as well as offline.

From the **Nav** menu, select **Station > Driver > BACnet Network > BACnet Device > Points**.

Double click on Points. The **Asc BACnet Point Manager** screen appears.

On the Discover button, click dropdown



Select **Offline** Option and click **Discover** button.

When a user click Discover button, the Asc BACnet Point Manager view splits into two panes, and at the same time typically launches a discovery "job".

**Discovered (top pane):** Lists BACnet object discovered on the driver's network.

A job "progress bar" is also included on top of the Discovered pane.

**Database (bottom pane):** Lists proxy points and point folders that are currently in the station database.

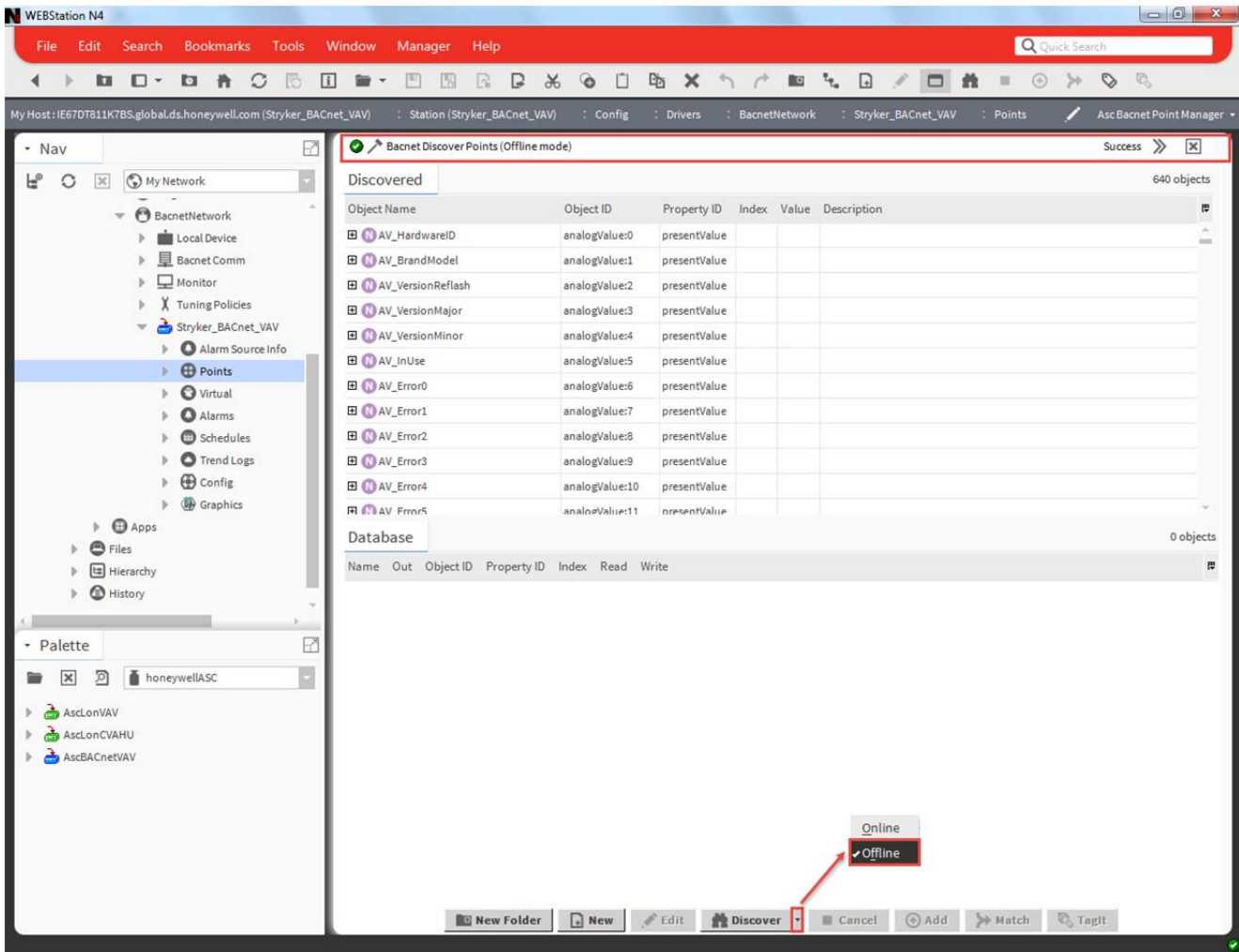


Figure 115: Offline Point Discovery

## ONLINE OPERATIONS

VAV controller can be connected online as described in [Configuration through WEBS Controller](#) or [Configuration through PC](#).

Following Online Operations can be performed when it is connected online.

### Download

Select the Controller from the left pane. Right click on it and select 'Download' as shown in [Figure 116](#).

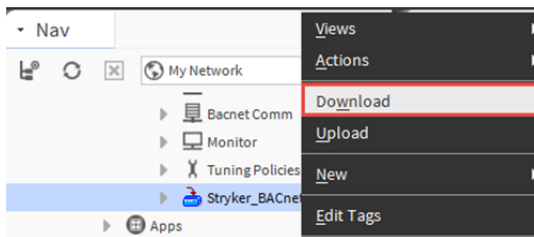


Figure 116: Selecting 'Download'

It is used to download the configuration from tool to controller.

### Upload

Select the Controller from the left pane. Right click on it and select 'Download' as shown in [Figure 117](#).

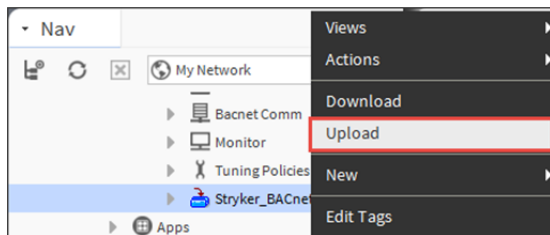


Figure 117: Selecting 'Upload'

Invoke this option to read configuration data from the controller and update the same in the tool database.

### Write Device Instance

A user can set the device instance number for a device so that each device in the network has a unique device instance number.

Select the Controller from the left pane. Right click on it and select Actions > 'Write Device Instance' as shown in [Figure 118](#).

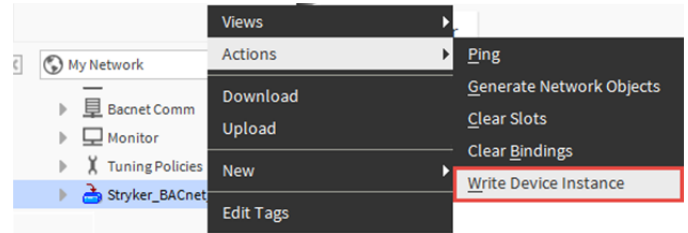


Figure 118: Write Device Instance

To select the other online operations to perform, select click 'VAV Configuration View' tab at the top right corner of the VAV Configuration Wizard window as shown in [Figure 119](#).

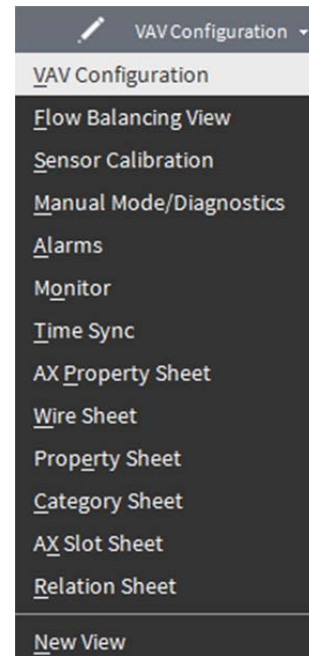


Figure 119: Online Operations from VAV Configuration View


### Flow Balancing View

The flow balancing view is used to balance a controller that is programmed with a standard VAV application. Based on the version of the VAV application and its features, the following operations can be performed on the view

- Flow pressure zero calibration
- Two point calibration
- K factor calibration
- Heating coil water flow calibration.

**Pre-requisites**

1. The controller must be online.
2. The controller must be in a commissioned state.
3. VAV Zone Terminal Single Duct must be selected as the Application Type and Air Balance Supported must be selected.

	<b>Note:</b>
<i>The selections must be done before downloading the program to the controller.</i>	

## Sensor Calibration

It is used to calibrate the sensors that are connected to the device. Using Sensor Calibration feature, a user can correct the input values to the controller. This action can be performed with the device in online mode. The controller must be in a commissioned state.

While performing Sensor Calibration, the device should not be used by another application. Only analog inputs to the controllers can be calibrated.

Select 'Sensor Calibration' option from VAV Configuration View tab as shown in [Figure 119](#). A window will pop up as shown in [Figure 124](#).

### Sensor Calibration for Stryker\_BACnet\_VAV

Sensor Name	Actual Value	Calibrated Value	Offset Value
Air flow	Inf in/wc	<input style="width: 60px;" type="text" value="Inf"/> in/wc	0.000 in/wc
Discharge temp	Inf °F	<input style="width: 60px;" type="text" value="Inf"/> °F	0.00 Δ°F
Outdoor temp	Inf °F	<input style="width: 60px;" type="text" value="Inf"/> °F	0.00 Δ°F
Space rel hum cntr	0.25 %	<input style="width: 60px;" type="text" value="-8.61"/> %	0.00 %

**Note:**  
If multiple inputs are configured as the same Zeleny sensor(C7400S) then only one of the inputs will be displayed in the calibration screen but the calibrated value will effect all the other inputs also.

**Figure 120: Sensor Calibration**

This shows the list of total analog inputs configured to the controller.

**Sensor name:** Displays the names of the sensors configured.

**Actual Value:** shows the current value of the sensor as read by controller.

**Calibrated Value:** shows the calibrated value to be entered.

**Offset value:** Click the  button to calculate the offset value. Offset value is a difference between Actual value and Calibrated value. It can be a positive or negative value.

## Manual Mode/Diagnostics

Diagnostics for Stryker_BACnet_VAV		
Modulating Output Diagnostics		
Name	Current Value	Edit Value
Damper motor	15.0 %	0 %
Binary Output Diagnostics		
Name	Current Value	Edit Value
Reheat_Stage - 1	OFF	OFF
Reheat_Stage - 2	OFF	OFF

Auto Refresh

Current Mode: Outputs Overridden Refresh Set

Figure 121: Manual Mode/Diagnostics

It is used to test the outputs of the Stryker VAV device when the outputs are overridden.

This action can only be performed with the device in online mode. The device must be in downloaded state.

The Diagnostics screen displays:

- All configured Digital Outputs to command ON/OFF.
- All configured Analog Outputs to command the values within 0 % to 100%.
- The values that are sensed (currently) at the outputs.

	<b>Note:</b>
<i>Before starting with diagnostics operations, make sure that the current mode is changed to 'Outputs Overridden' from 'Auto'.</i>	
Current Mode: <span>Outputs Overridden</span>	

### Modulating Output Diagnostics

The number of Modulating Outputs depend on the outputs configured in the application.

**Current Value:** it displays the value of the modulating output as read from the controller

This field is non-editable.

**Edit Value:** Enter the value that is required to command the output.

The range is 0 % to 100 %.

When the value is entered, click Set button to feed the value to the selected output.

### Binary Output Diagnostics

The number of Binary Outputs depends on the outputs are configured in the application.

**Current Value:** It displays the value of the modulating output as read from the controller.

This field is non-editable.

**Edit Value:** Select the value as ON or OFF to command the output.

When the value is entered, click Set button to feed the value to the selected output.

### Refresh

Click the Refresh button to refresh the output values, only when the device is in Manual mode.

### Auto Refresh

Auto Refresh Check this option, 'to automatically refresh' the output values every 30 secs.


## Alarms

Alarms for Stryker_BACnet_VAV		
Error	Type of Error	Details
UI_1	UI_1outLive	Outdoor temp has failed
WMCommError	Sylk Network Communication Error	The TR71/75 device has failed to respond

Auto Refresh   

Figure 122: Viewing Alarms

Alarm window shows errors logged by the Stryker VAV controller. This action can be performed only when the device is in the online mode. The controller must be in a commissioned state.

	<b>Note:</b>
The controller is capable of tracking and reporting several types of errors.	

Groups of errors of the same type are also reported as an alarm by the controller. This means, the several different errors of the same type will be reported as a single alarm.

For Example, multiple sensors connected to the controller may read invalid values and the controller will log individual errors for each sensor. However, a single 'SensorFailure' alarm will be reported. As shown in [Figure 122](#), this screen displays all the errors that are currently active and reported by the controller.

### Error

This column displays the name of the errors.

### Type of Error

It shows the type of the error. Errors could be one of the following types:

1. Sensor Error
2. BACnet Network Communication Error
3. Control Error
4. Sylkbus communication error
5. Node disabled error

### Details

The description of the error is mentioned in this field.

### Refresh

Click the  button to refresh the error list manually and see the current errors.

### Auto Refresh

Auto Refresh If this option is selected, the alarms view/data refreshes automatically every 30 seconds to show the current errors.

## Monitor

This option provides important parameters for monitoring the system operation. Few parameters with property of read/write can be overridden for functional testing of the VAV controller.

This action can be performed with the device in online mode. The controller must be in a commissioned state.

Monitoring for Stryker\_BACnet\_VAV

Current Mode:

Name	Read Value	Write Value	Unit
Temperature Setpoint	Invalid	<input type="text" value="NaN"/>	°F
Effective Setpoint	74.0	NA	°F
Schedule Occupancy	Occupied	NA	NA
Manual Occupancy	occNull	<input type="text" value="occNull"/>	NA
Effective Occupancy	Occupied	NA	NA
Application Mode	Null	<input type="text" value="Auto"/>	NA
Device Mode	Cool	NA	NA
Box Airflow Setpoint	Invalid	NA	cfm
Box Flow	Invalid	NA	cfm
Damper Position	15.0	NA	%
Reheat	0	NA	NA
DLC Shed Status	OFF	NA	NA
Space temp	Invalid	NA	°F
Space rel hum cntr	0.2	NA	%
Supply temp	Invalid	NA	°F
Discharge temp	Invalid	NA	°F
Outdoor temp	Invalid	NA	°F

**Note:**

- 1.If the read and write values don't match during load then refresh the view.  
This could happen because of the delay when reading the values from the device.
- 2.Only configured points are displayed.
- 3.In manual mode the actual values in the controller and monitor screen values may not match.
- 4.Clicking the Write button will periodically write the specified values to the controller until either the view is closed or the Write is clicked again with changed values.

Figure 123: Monitoring the system operation.

**Current Mode**

Current Mode: Auto

This field displays whether the controller is in manual control or in auto mode.

**Name**

This column displays the names of configured parameters.

**Read value**


**This column displays the current value of the parameters read from the controlled.**

**Write value**

This field enables user to write the expected value to the controller.

**Unit**

This column displays the respective units of the parameters.

	<b>Note:</b>
<p><i>For the Monitor Sensor input, the value will be displayed as reported from the controller even if the value lies outside the range of the sensor type that is configured. If the value reported from the controller is +inf or -inf or NaN then the text Invalid will be displayed.</i></p>	

## Time Sync

It is used to set the time as per the time zone in the device.

Features like scheduling and day light savings will not work correctly if the device does not have a valid date and time set. This action can only be performed with the device in online mode.

The controller must be in a commissioned state. While performing this online operation, the device should not be in use by another application.

Select 'Time Sync' option from VAV Configuration View tab as shown in [Figure 119](#).

A window will pop up as shown in [Figure 124](#).

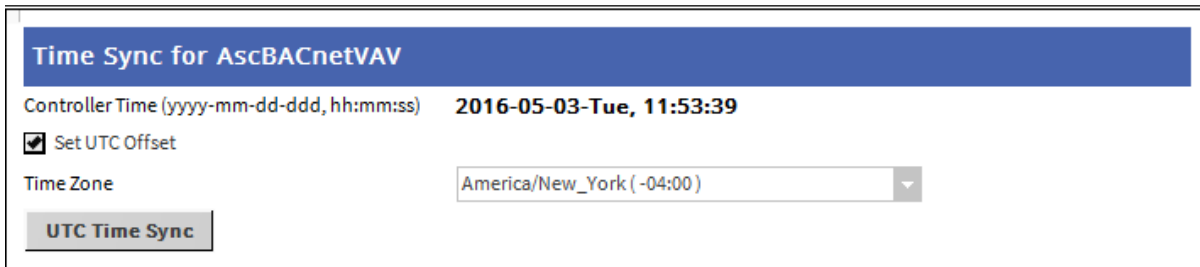


Figure 124: Set Time

**Automation and Control Solutions**

Honeywell International Inc.  
 1985 Douglas Drive North  
 Golden Valley, MN 55422  
 customer.honeywell.com

® U.S. Registered Trademark  
 © 2016 Honeywell International Inc.  
 31-00104-01 M.S. 05-16  
 Printed in United States

