

Honeywell

Solid Core and Split Core 4-20 mA Output Current Sensors

CTS-A AND CTP-A SERIES

INSTALLATION INSTRUCTIONS

APPLICATION

The 4-20 mA Output Analog Current Sensors are designed for use in any AC current monitoring application in which you are looking to monitor a particular piece of equipment.

SPECIFICATIONS

Monitored Current Type: AC Current

Maximum AC Voltage: 600 VAC

Isolation Voltage: 2200 VAC

Supply Voltage:

+8.5 to 30 VDC (Reverse Polarity Protected)
250 Ohm Load (1-5 VDC): +13.5 to 30 VDC
500 Ohm Load (2-10 VDC): +18.5 to 30 VDC

Operating Temperature Range: 5 to 104°F (-15 to 40°C)

Operating Humidity Range: 0 to 95%, non-condensing

Wire Recommendations: 2 Conductor (Shielded Cable)

Wire Size:

18 to 24 AWG (0.823 mm² to 0.205 mm) Copper Wires only

Terminal Block Torque Rating: 4.43 to 5.31 in.-lbs. (0.5 to 0.6 Nm)

Minimum Mounting Distance:

1" (2.6 cm) between current sensor & other magnetic devices (Relays, Contactors, Transformers)

Agency Approvals:

CE (-RMS Versions): CE to IEC 61326-1: 2012 Class A,
UL/CUL US Listed (UL 508) Ind. Control Equipment
(File # E309723), RoHS2, WEEE

STANDARD ORDERING

Table 1. Standard Ordering.

Model #	Selectable Ranges	Measurement	AC Waveform	Solid-Core	Split-Core	Output Signal
CTS-A-250	0 to 100/200/250A	Average	Pure Sinusoidal	•		4 to 20 mA
CTP-A-200	0 to 100/150/200A	Average	Pure Sinusoidal		•	4 to 20 mA
CTP-A-50-RMS	0 to 10/20/50A	True RMS	Distorted & Pure Sinusoidal		•	4 to 20 mA

NOTE: The 4-20 mA Output Current Sensors are not intended to be used in life/safety applications or in hazardous/classified locations.



31-00142-01

PLEASE READ INSTRUCTIONS CAREFULLY BEFORE INSTALLATION!

⚠ WARNING

- This product is not intended to be used for Life or Safety applications.
- This product is not intended for use in any hazardous or classified locations.
- The CTS-A and CTP-A Series Current Sensors must be used on Insulated Conductors Only!

**⚠ WARNING
HIGH VOLTAGE**

Disconnect and lock out all power sources before installation as severe injury or death may result from electrical shock due to contact with high voltage wires.

INSTALLATION

Make sure that all installations are in compliance with all national and local electrical codes. Only qualified individuals that are familiar with codes, standards, and proper safety procedures for high-voltage installations should attempt installation. The current sensor is a 2-wire, 4 to 20 mA Loop Powered device that requires a regulated +13.5 to 30VDC external power source.

The current sensor may be mounted in any position using the two #8 x 3/4" Tek screws and the mounting holes in the base, or snapped directly on to the 35mm DIN rail (See Fig. 1. Leave a minimum distance of 1" (3 cm) between the current sensor and any other magnetic devices such as contactors and transformers.

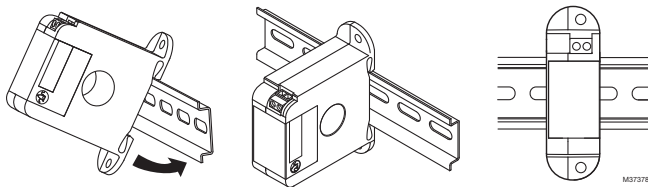

Fig. 1. Sensor Placed On Rail.

Latch Operation for CTP-A Series

Press down on the side tab and swing the top of the unit up to open the split core current sensor as shown in Fig. 2. Press down firmly on the cover to close the current sensor. An audible “click” will be heard as the tab slides over the tongue on the base.

⚠ CAUTION

Mating surfaces of the magnetic core are exposed when the sensor is open. Electrical contact grease, present on the cores to prevent corrosion, can capture grit and dirt if care is not exercised. Operation can be impaired if anything prevents good contact between pole pieces. Visually check the mating parts of the core before closing the current sensor.

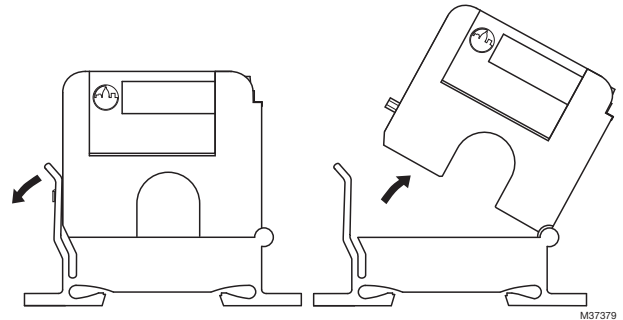

Fig. 2. Opening Split Core Models.

CURRENT SENSOR SETUP

The amperage range selected represents the maximum current that can be applied to the conductor being monitored. **DO NOT EXCEED!** All current sensors with selectable ranges will have the range selection jumper factory set on the high range. For models with field selectable amperage ranges, select the correct amperage range using the range selection jumper. Note that all RMS models have True RMS outputs and should be used with Variable Frequency Drives.

WIRING

We recommend the use of a two conductor 16 to 22 AWG shielded cable, **COPPER WIRE ONLY**, for all 4 to 20mA current sensor installations. A maximum wire length of less than 30 meters (98.4 feet) should be used between the current sensors and the Building Management System or controller.

NOTE: When using a shielded cable, be sure to connect only (1) end of the shield to ground at the controller. Connecting both ends of the shield to ground may cause a ground loop.

When removing the shield from the sensor end, make sure to properly trim the shield to prevent any chance of shorting. The current sensor terminals are polarity sensitive and represent a linear and proportional 4 to 20mA output signal. The current sensors are available in either an Average or True RMS output version. Tighten the screws at the terminal block connections to the recommended torque of 0.5 to 0.6 Nm (4.43 to 5.31 in-lbs.). The aperture (hole) size of the current sensor is 0.75" (1.90 cm).

Application Example

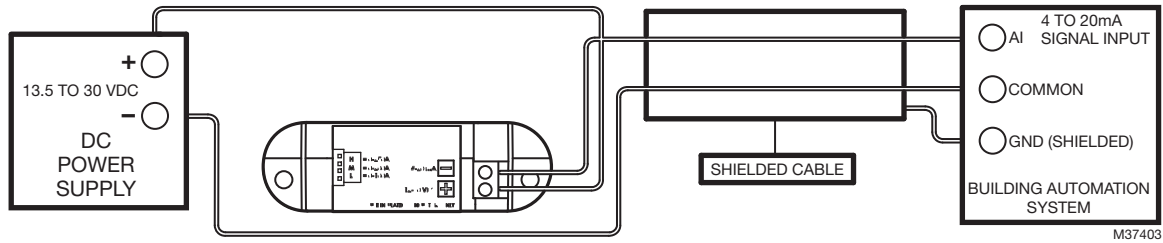

Fig. 3. Analog circuit.

TROUBLESHOOTING

Table 2. Troubleshooting.

Problem	Solution
No reading	<ul style="list-style-type: none"> Confirm that you have +13.5 to 30VDC in series with the current sensor output terminals and the analog input of the control panel. Check the polarity of the circuit. Verify that the terminals are screwed down, wires are firmly in place. Disconnect the input to the control panel and then insert a current meter (mA range) in series with the current sensor output to verify that the circuit is working properly.
Erratic readings	<ul style="list-style-type: none"> Verify that the wires are terminated properly. Check that the +13.5 to 30VDC input is clean. In areas of high RF interference, shielded cable may be necessary to stabilize signal.
Inaccurate readings	<ul style="list-style-type: none"> If you suspect that the current sensor is not reading within the accuracy specifications, please contact the factory for assistance.
Current Sensor is operating at a low-level current or failing to operate within the accuracy specifications.	<ul style="list-style-type: none"> Visually check the mating parts of the core to ensure there is no debris between the split contacts. See Fig. 2. Remove all debris or dust manually and close the current sensor. Continue to retest the sensor in your application.

CURRENT CONVERSION FORMULAS

TO CONVERT THE CURRENT SENSOR OUTPUT SIGNAL TO A CURRENT READING:

4-20mA output to Current reading
(4mA = 0 Amps and 20mA = 250 Amps for A/CTA2-250)

Example: 12mA current sensor output signal
Total Span = 250 Amps
Multiplier = $20\text{mA} - 4\text{mA} / \text{Total Span} = 0.064$
 $(12\text{mA} - 4\text{mA}) / 0.064 = \mathbf{125 \text{ AMPS}}$

WEEE DIRECTIVE

At the end of their useful life the packaging and product should be disposed of via a suitable recycling center. Do not dispose of with household waste. Do not burn.

CHINA ROHS COMPLIANCE INFORMATION ENVIRONMENT-FRIENDLY USE PERIOD (EFUP) TABLE

部件名称 Component Name	有害物质 - Hazardous Substances					
	铅 (Pb) Lead (Pb)	汞 (Hg) Mercury (Hg)	镉 (Cd) Cadmium (Cd)	六价铬 (Cr6+) Chromium VI Compounds (Cr6+)	多溴联苯 (PBB) Polybrominated Biphenyls (PBB)	多溴二苯醚 (PBDE) Polybrominated Diphenyl Ethers (PBDE)
Assorted capacitors	0	0	0	0	0	0
Assorted resistors	0	0	0	0	0	0
Core	0	0	0	0	0	0
Screw	0	0	0	0	0	0

本表格依据 SJ/T 11364 的规定编制。

O: 表示该有害物质在该部件所有均质材料中的含量均在 GB/T 26572 规定的限量要求以下。

X: 表示该有害物质至少在该部件的某一均质材料中的含量超出 GB/T 26572 规定的限量要求。

This table is prepared in accordance with the provisions of SJ/T 11364.

O: Indicates that said hazardous substance contained in all of the homogeneous materials for this part is below the limit requirement of GB/T 26572.

X: Indicates that said hazardous substance contained in all of the homogeneous materials for this part is above the limit requirement of GB/T 26572.

未列入表内的其他部件，皆不含任何超出限量要求的限制使用物质。

All other components, not listed in the table, do not contain restricted substances above the threshold level.

REGULATORY INFORMATION

FCC REGULATIONS: § 15.19 (A)(3)

This device complies with part 15 of the FCC Rules.

Operation is subject to the following two conditions:

1. This device may not cause harmful interference, and
2. This device must accept any interference received, including interference that may cause undesired operation.

IC REGULATIONS: RSS-GEN

This device complies with Industry Canada's license-exempt RSSs.

Operation is subject to the following two conditions:

1. This device may not cause interference; and
2. This device must accept any interference, including interference that may cause undesired operation of the device.

Le présent appareil est conforme aux CNR d'Industrie Canada applicables aux appareils radio exempts de licence. L'exploitation est autorisée aux deux conditions suivantes :

1. l'appareil ne doit pas produire de brouillage;
2. l'utilisateur de l'appareil doit accepter tout brouillage radioélectrique subi, même si le brouillage est susceptible d'en compromettre le fonctionnement.

FCC WARNING (PART 15.21) (USA ONLY)

Changes or modifications not expressly approved by the party responsible for compliance could void the user's authority to operate the equipment.

By using this Honeywell literature, you agree that Honeywell will have no liability for any damages arising out of your use or modification to, the literature. You will defend and indemnify Honeywell, its affiliates and subsidiaries, from and against any liability, cost, or damages, including attorneys' fees, arising out of, or resulting from, any modification to the literature by you.

Home and Building Technologies

In the U.S.:

Honeywell

715 Peachtree Street NE

Atlanta, GA 30308

customer.honeywell.com

Honeywell

® U.S. Registered Trademark
© 2018 Honeywell International Inc.
31-00142-01 M.S. 04-18
Printed in United States