

Compact I/O Module

XIO-8AI UNIVERSAL ANALOG INPUT MODULE

INSTALLATION INSTRUCTIONS



GENERAL

The Honeywell XIO-8AI Universal LON[®] Analog Input Module is a LON module with 8 configurable temperature or voltage inputs to record temperatures and voltages of passive and active sensors for example, electrical ventilation and mixing valves, valve positions etc. The recorded counted measurands are produced in different formats. Temperature, resistance, percentage and voltage can be read out depending on the setting for each input, and bound to other LonMark[®] devices. The setting of sensor characteristics and measuring ranges are done by LNS[®]-Plugin. The supply voltage for active sensors can be provided by the module.

SPECIFICATIONS

Electrical Ratings:

Supply Operating Voltage: 20 to 28 V AC/DC.
Current Consumption: 57 mA (AC) / 30 mA (DC).
Duty cycle: 100%.
Recovery time: 550 ms.

Terminal Blocks:

Supply and Bus: 16 AWG (1.5 mm²).
(Terminal block and strapping plug included in packing).
Analog Inputs: 14 AWG (2.5 mm²).

LON Interface:

Transceiver: FTT10A free topology.
Neuron: 3150, 64k Flash.
Data format: standard network variables (SNVT).
Transmission rate: 78 kBit/s.
Maximum Length:
line topology 8858 ft. (2700 m) / 64 nodes.
free topology 1640 ft. (500 m) / 64 nodes.
Cabling: twisted pair.

Temperature Ratings:

Operating: 23° F to 131° F (-5° C to +55° C).
Storage: -4° F to +158° F (-20° C to +70° C).

Dimensions (W x H x D):

2.0 x 2.7 x 2.6 in. (30 x 68 x 65 mm).

Weight: 4.4 ounces (126 g).

Mounting Position: Any.

Mounting: DIN rail per EN 50022.

Input:

Temperature Range: selectable.

NOTE: Temperature input for all sensors is in the range of 40 Ω up to 4 MΩ.

Resolution: 0.2 K.

Error: approximately ± 0.4° F (±0.2° C).

Voltage input: 0 to 10 V DC.

Resolution: 10 mV (0.0 to 100%).

Error: approximately ±100 mV.

Construction Material:

Housing and Terminal Blocks: Polyamide 6.6 V0.
Faceplate: Polycarbonate.

Protective Circuitry:

Operating Voltage: polarity reversal protection.

Protection:

IP40 housing DIN 40050.

IP20 terminal blocks DIN 40050.

Approvals:

UL 916, Standard for Energy Management Equipment.
European Community Mark (CE) Listed.



SAFETY INSTRUCTIONS

NOTES REGARDING DEVICE DESCRIPTION

These instructions include indications for use and mounting of the device. In case of questions that cannot be answered with these instructions, please consult the product supplier or manufacturer. It is the responsibility of the equipment installer to ensure that all federal, state and local codes are followed.

SAFETY INSTRUCTIONS

- Keep these Installation Instructions for industrial safety and the prevention of accidents.
- Only qualified personnel shall do mounting and installation work with these devices, see section titled “Qualified Personnel”.
- The information in these instructions must be read and understood by every person using this device.

QUALIFIED PERSONNEL

Qualified personnel in the sense of these instructions are persons who are well versed in the use and installation of such devices and whose professional qualification meets the requirements of their work.

This includes, for example:

- Qualification to connect the device according to applicable specifications and regulations, and a qualification to put this device into operation, to power it down, or to activate it by respecting the internal directions.
- Knowledge of safety rules.
- Knowledge about application and use of the device within the equipment system.

BEFORE INSTALLATION

1. Unpack the XIO-8AI Universal LON Analog Input Module.
2. Check the equipment and report any damage to a Honeywell representative.
3. Read all of these instructions and ensure they are understood.

MOUNTING

Mount the XIO-8AI Universal LON Analog Input Module on standard DIN rail per DIN EN 50022 (1.35 x 0.3 in. [35 x 7.5 mm]), in junction boxes and/or on distribution panels.

INSTALLATION



CAUTION

Electrical installation and device termination shall be accomplished by qualified persons only, by respecting all applicable specifications and regulations.

1. Power down the equipment. Mount the module on the DIN rail.

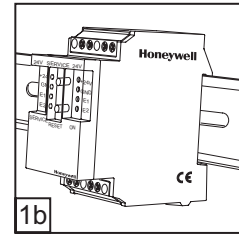
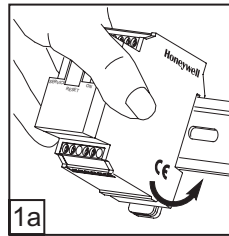

2. Plug in the terminal block for bus connection.

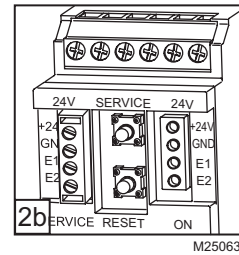
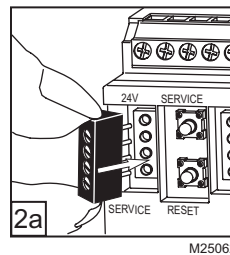

3. Prepare the cable for bus connection:

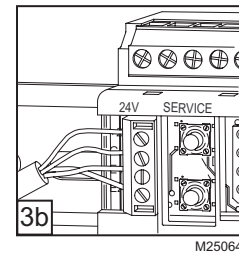
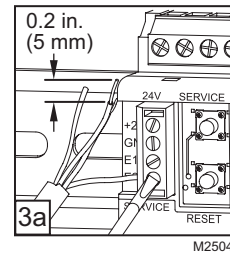

- a. Remove about 0.75 in. (2 cm) of the plastic cable sheath.
- b. Strip 0.2 in. (5 mm) insulation from each wire. Put a wire end sleeve to stranded wires.
- c. Insert the wire to the respective contact and secure it by screwing down the contact screw.
- d. Wire cross section of the 4 pole terminal block bus/ mains connection:
 - (1) Maximum 16 AWG (1.5 mm²) single wire.
 - (2) Maximum 18 AWG (1.0 mm²) stranded wire.
 - (3) Wire diameter minimum 28 AWG (0.3 mm) up to 16 AWG (1.4 mm).

4. Prepare cable for module connections.

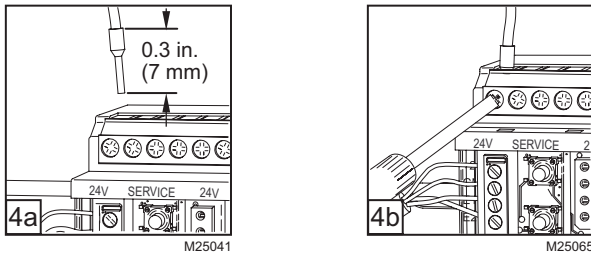

- a. Strip the wires by 0.3 in. (7 mm). Put a wire end sleeve on stranded wires.
 - b. Insert the wire into the respective module contact and secure it by screwing down the contact screw.
 - c. Wire cross section of the 4 pole terminal block bus/ mains connection:
 - (1) Maximum 12 AWG (4.0 mm²) single wire.
 - (2) Maximum 14 AWG (2.5 mm²) stranded wire.
 - (3) Wire diameter minimum 28 AWG (0.3 mm) up to 10 AWG (2.7 mm).
5. The module can be aligned without interspace. Use the strapping plug to connect bus and supply voltage when the modules are mounted in series. The modules can be mounted in series without interspace. The maximum number of modules connected in series is 15, with each group needing an external power supply.

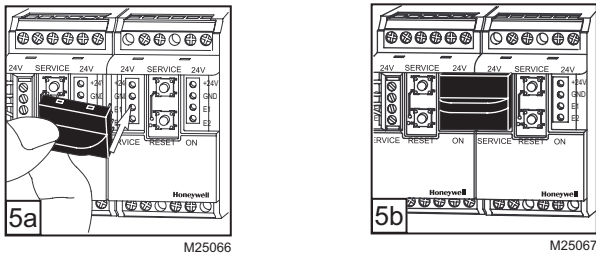

TERMINATION

Fig. 1 shows the termination points of the XIO-8AI.

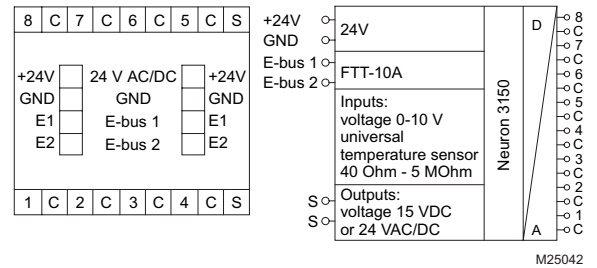

Fig. 1. Termination diagram for XIO-8AI.

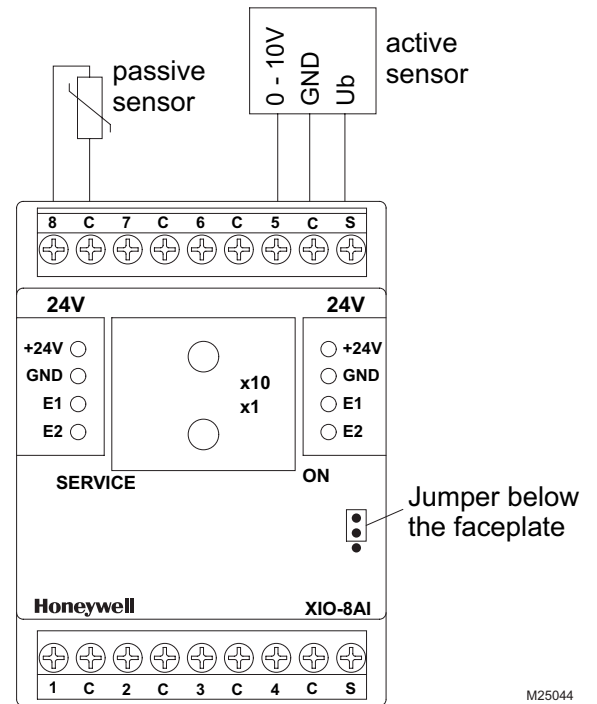

Fig. 2. XIO-8AI Termination example.

JUMPER POSITIONS

Fig. 3 illustrates the two jumper positions for the voltage supply of active sensors.

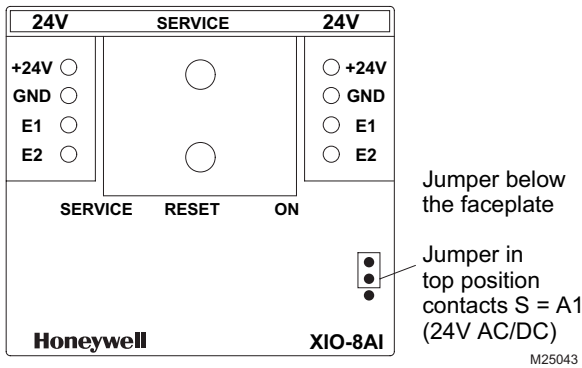
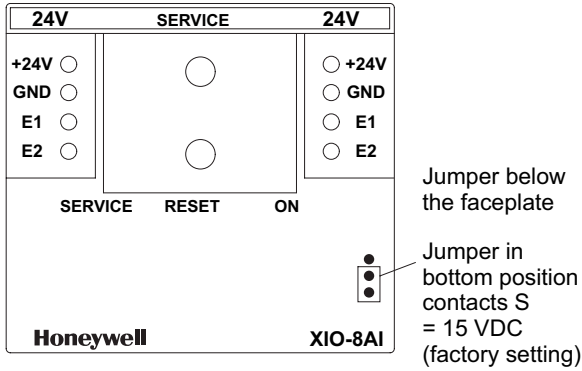

Fig. 3. XIO-8AI Jumper positions.

WIRING

Wiring of the XIO-8AI must be accomplished in accordance with federal, state, and local requirements. Figures 4 through 6 show sample diagrams of wiring of the XIO-8AI.

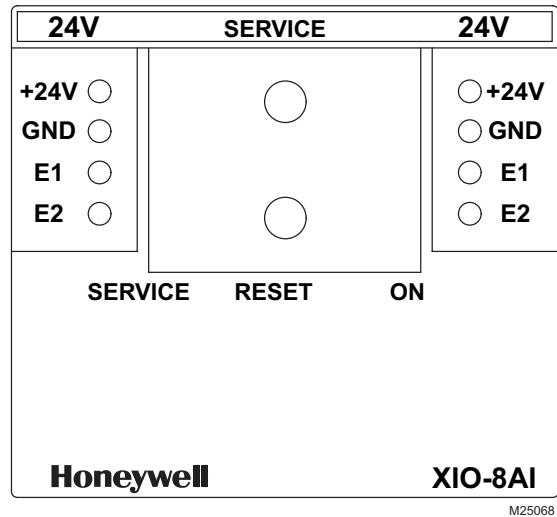
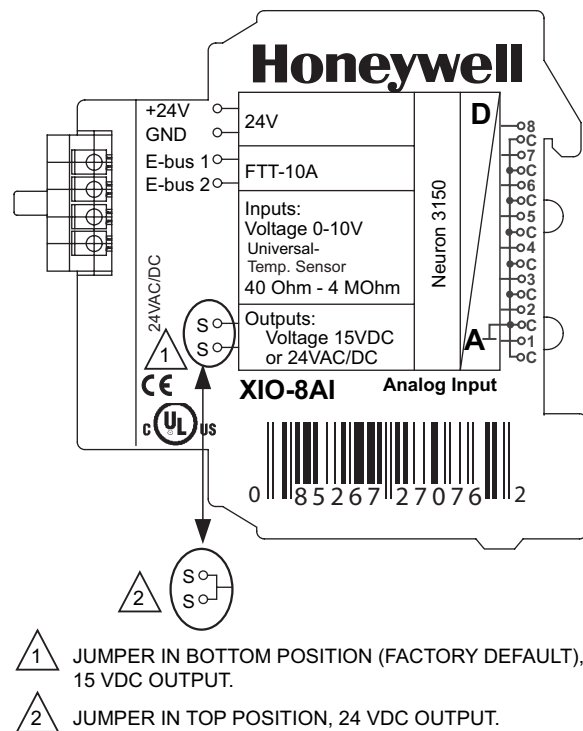

Fig. 4. Front panel diagram of XIO-8AI.



- 1 JUMPER IN BOTTOM POSITION (FACTORY DEFAULT), 15 VDC OUTPUT.
- 2 JUMPER IN TOP POSITION, 24 VDC OUTPUT.

M25069A

Fig. 5. Side panel diagram of XIO-8AI.

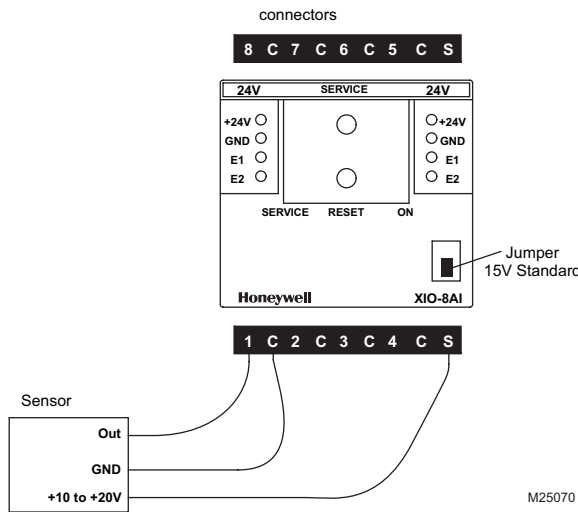

Fig. 6. Wiring example XIO-8AI with sensor.

SOFTWARE DESCRIPTION

The Node Object monitors and controls the functions of the different objects in the device. It supports the basic functions Object-Status and Object-Request required by LonMark. Refer to Fig. 7 for a basic illustration of Node Objects. The following objects are monitored by the Node Object.

nviRequest **NVT_obj_request**
nvoStatus **SNVT_obj_status**
nvoFileDirectory **SNVT_address**

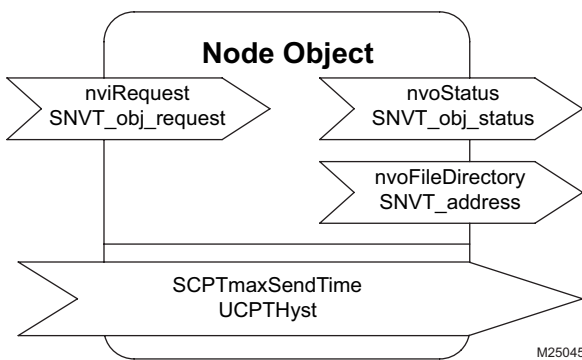

Fig. 7. XIO-8AI Node Object.

SCPTmaxSendTime **SNVT_time_sec**
 All output variables described below will be issued at the latest at the end of the preset period even without status change.
 Time settings: 0 timer function off-state
 6553,8 s (factory setting 60 s)

UCPTHyst

Setting of the hysteresis; the output variables nvoHigh and nvoLow switch over when the hysteresis is expired (factory setting 2 Kelvin).5; 1. counted measurand = 1.

SNVT_temp_p

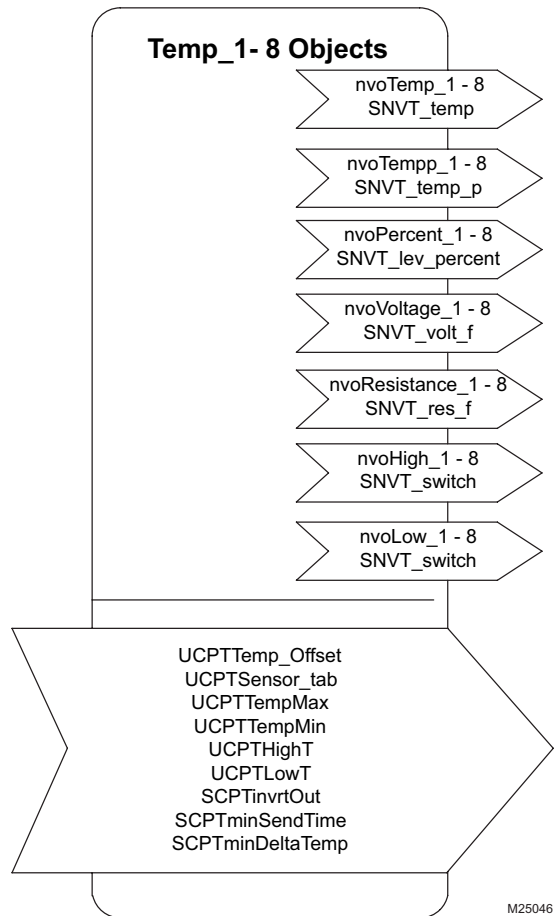

Fig. 8. XIO-8AI Temp Objects.

nvoTemp_1...8

SNVT_temp

The output variable supplies a value with format ° C depending on the input signal of 0 to 10.0 V and the settings in UCPTTempHigh and UCPTTempLow and/or the resistance of the selected temperature sensor.

nvoTemp_1...8

SNVT_temp_p

See Temp_1...8 but with 0.01° C format.

nvoPercent_1...8

SNVT_lev_percent

The output variable supplies a value with format 0 to 100.0% for voltage measurements depending on the input signal of 0 to 10.0 Volt.

nvoVoltage_1...8

SNVT_volt_f

The output variable supplies a value with format 0 to 10.0 Volt for voltage measurements depending on the input voltage.

nvoResistance_1...8

SNVT_res_f

The output variable supplies a value with format Ohm depending on the input signal of 40 Ohm to 4 MOhm.

nvoHigh_1...8

When exceeding the temperature set in UCPTHHighT the output variable changes from 0,0 0 to 100,0 1. When under-running the temperature set in UCPTHHighT plus the hysteresis set in UCPTHyst the output variable changes from 100,01 to 0,0 0.

SNVT_switch

nvoLow_1...8

When under-running the temperature set in UCPTLowT the output variable changes from 0,0 0 to 100,0 1. When exceeding the temperature set in UCPTLowT plus the hysteresis in UCPTHyst the output variable changes from 100,0 1 to 0,0 0.

SNVT_switch

UCPTTemp_Offset

SNVT_temp

The respective measurand can be readjusted in steps of 0.1 K.

UCPTSensor_tab

Temperature ° F (° C)	Resistance	Sensor Name	ST_ON (Resistance)	ST_OFF (Voltage)

Factory setting: NTC20k in the range -22° F to 266° F (-30° C to +130° C).

UCPTTempMax

SNVT_temp Werk:
+ 302° F (+150° C)

UCPTHHighT

SNVT_temp Werk:
+212° F (+100° C)

UCPTTempMin

SNVT_temp Werk:
- 58° F (-50° C)

UCPTLowT

SNVT_temp Werk:
-14° F (-10° C)

The temperature output variables are calculated during voltage measurements according to a 0 to 10 Volt input signal and the here selected range.

Setting of the thresholds nvoHigh and nviLow to make the switch variables switch over.

SCPTInvtOut

SNVT_lev_disc

Inverting the values at nvoHigh or nvoLow.

LON®, LonMark®, LNS® and Echelon® are registered trademarks of Echelon Corporation.

By using this Honeywell literature, you agree that Honeywell will have no liability for any damages arising out of your use or modification to, the literature. You will defend and indemnify Honeywell, its affiliates and subsidiaries, from and against any liability, cost, or damages, including attorneys' fees, arising out of, or resulting from, any modification to the literature by you.

Automation and Control Solutions

Honeywell International Inc.
1985 Douglas Drive North
Golden Valley, MN 55422
customer.honeywell.com

Honeywell Limited-Honeywell Limitée
35 Dynamic Drive
Scarborough, Ontario M1V 4Z9

