

INTRODUCTION

The Condensation Prevention Sensor uses a field-proven RH sensor combined with a tightly-coupled precision thermistor to provide early warning of condensing conditions in chilled beam / ceiling applications and prevent "indoor rain" condensation. The sensor can also be used in any heating, ventilation or air conditioning application to where condensation must be avoided.

The sensor features a Form-C dry-contact output signal, LED status indication, setpoint adjustment and an attractive compact enclosure.

The device includes cable ties for quick and simple pipe mounting. The enclosure also has provisions for screw mounting to a surface in non-pipe installations.

BEFORE INSTALLATION

Read these instructions carefully before installing and commissioning the condensation sensor. Failure to follow these instructions may result in product damage. Do not use in an explosive or hazardous environment, with combustible or flammable gases, as a safety or emergency stop device or in any other application where failure of the product could result in personal injury. **Do not exceed the device ratings.**

MOUNTING

The sensor can be mounted directly to a pipe or wall. The metal plate mounting base has a curvature to fit pipes up to 2" (50.8 mm) in diameter for minimal installation effort.

Do not install the sensor where air flows or heat sources can interfere with its normal operation, or in areas of high vibration. Do install the sensor on an area of the pipe or wall which is most susceptible to the formation of condensation water, such as near the chilled water inlet. The sensor base must have direct thermal contact with the pipe or wall, ensure the mounting area is clean and free of debris, and do not cover the sensor with insulation or otherwise block the enclosure air vents. Ensure ambient air can enter and circulate around the sensor.

Use the two supplied tie wraps to secure the sensor to the pipe. Feed the tie wraps through the two slot openings on the side of the enclosure and around the pipe being mounted to. Tighten the tie wraps until the sensor is secure. See Figure 1.

For wall mounting, use two #6 screws through the holes in the enclosure sides and ensure the enclosure is flush against the wall. Do not over-tighten the screws See Figure 2.

Correct pipe mounting is shown in Figure 4. Wall mounting installations are shown in Figure 5.

Figure 1

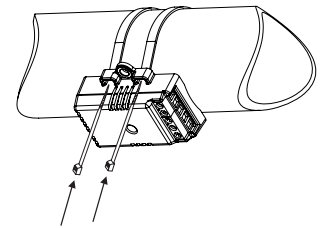

Do not mount the sensor on the top side of the pipe

Figure 2

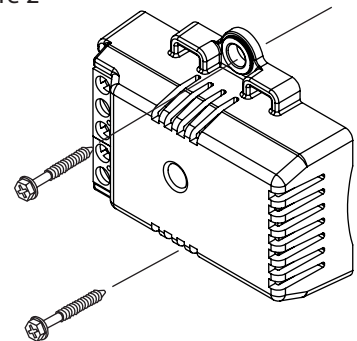

Figure 3

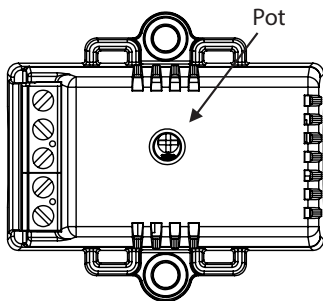
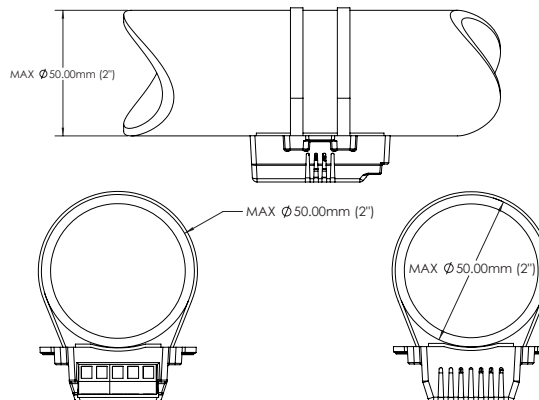
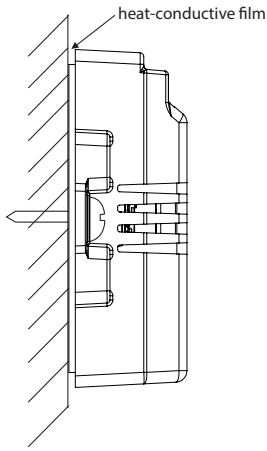

Figure 4





WIRING

- Deactivate the 24 Vac/dc power supply until all connections are made to the device to prevent electrical shock or equipment damage. Follow proper electrostatic discharge (ESD) handling procedures when installing the device or equipment damage may occur.
- Use 14-22 AWG shielded wiring for all connections and do not locate the device wires in the same conduit with wiring used to supply inductive loads such as motors. Make all connections in accordance with national and local codes.
- Complete the wiring connection according to Figure 6.
- Connect the plus DC or the AC voltage hot side to the PWR terminal. Connect the power supply common to GND terminal. The device is reverse voltage protected and will not operate if connected backwards.
- The relay is a Form C type with both normally open (NO) and normally closed (NC) contact. The relay contacts may be connected to a controller Digital Input (DI) for status monitoring or used to directly control an alarm or ventilation fan. Do not exceed the device contact ratings. In some cases, a separate control relay may be used between the sensor relay and a large fan, for example. Relay terminals are designated NO, COM, and NC. The relay output is independent and isolated from the device GND.
- Once all connections settings are verified, power can be applied.

Figure 6

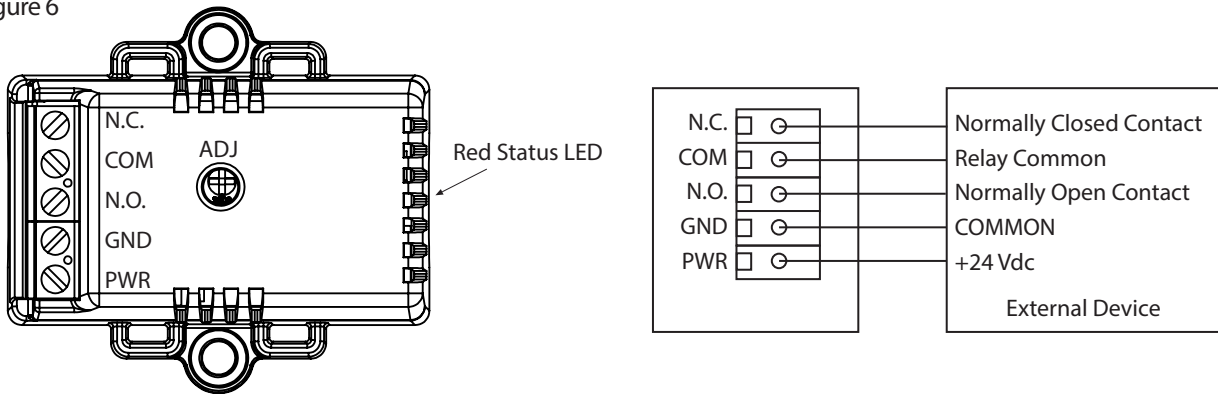

OPERATION

Upon applying power to the device, the sensor will monitor the temperature of the surface that the device is mounted to and the relative humidity of the surrounding air. The dewpoint will be determined based on its sensors and will trigger the alarm relay before the condensation point is reached on the surface being monitored.

The device has a red LED that will blink every ten seconds during normal operation. When an alarm condition is detected the LED will remain on as long as the alarm condition exists.

The sensor has an accessible adjustment pot, marked ADJ on the top cover of the enclosure. The pot will adjust the dewpoint trip point for alarm by ± 2 °C. To reduce dewpoint temperature (and force the alarm to trigger earlier), turn the pot counter-clockwise. To increase the dew point temperature (and force the alarm to trigger later), turn the pot clockwise. Use a small flat head screwdriver to adjust. The pot is set to midpoint when shipped. Adjustment can be done in the field to compensate for environmental conditions.

DIMENSIONS

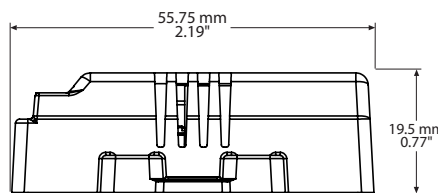
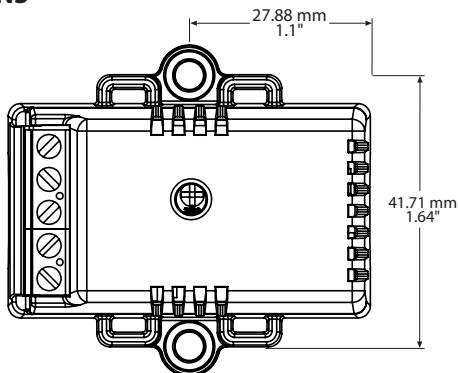

SPECIFICATIONS

SENSOR

- Temperature Accuracy..... $\pm 0.2^{\circ}\text{C}$ ($\pm 0.4^{\circ}\text{F}$), 0 to 50°C (32 to 122°F)
- Humidity Accuracy..... $\pm 3\%$ RH @ 90 %RH
- Response Time <1 second
- Setpoint Range..... $\pm 2^{\circ}\text{C}$ (dewpoint)
- Alarm Contact Rating..... Form C (NO + NC), 1 A @ 24 Vac/dc
- Alarm Hysteresis 1 minute delay on alarm to prevent false alarms

ENCLOSURE

- Dimensions..... 56mm x 50mm x 21mm
- Material..... White ABS
- Ratings..... IP30 (NEMA 1)
- Weight 35 grams

GENERAL

- Power Supply 5 to 28 Vac/dc
- Consumption 3 mA max @ 24 Vdc max
- Operating Conditions 0 to 50°C (32 to 122°F)
5 to 95 %RH non-condensing
- Storage Conditions..... -30 to 70°C (-22 to 158°F)
- Wiring Connections..... 14-22 AWG terminal block
- Country of Origin..... Canada