

B524BI and B224BI Plug-in Isolator  
Detector Bases



A Division of Pittway  
3825 Ohio Avenue, St. Charles, Illinois 60174  
1-800-SENSOR2, FAX: 630-377-6495

**For use with the following smoke detectors:**

<b>In US:</b>	<b>B524BI:</b>	<b>1551, 2551, 2551T, 5551, 5551R</b>
	<b>B224BI:</b>	<b>1251, 2251, 3251</b>

Specifications

Base Diameter:	6.2 inches (157 mm)
Base Height	
B224BI:	1.2 inches (31 mm)
B524BI:	1.4 inches (36 mm)
Mounting:	4-inch square box with or without plaster ring, Min. depth - 1.5 inches (13 mm) 4-inch octagon box, Min. depth - 1.5 inches (13 mm) 3-1/2-inch octagon box, Min. depth - 1.5 inches (13 mm)
Operating Temperature Range:	-10°C to + 60°C (14° F to 140° F) NOTE: Do not install in locations where normal ambient temperature extends beyond 0° to 49°C (32° to 120° F)
Operating Humidity Range:	10% to 93% Relative Humidity (Non-condensing)

**Electrical Ratings**

Operating Voltage:	15 to 28 VDC
Current	
Standard:	450µA Maximum
Alarm:	5mA Maximum

Before Installing

Please thoroughly read the system wiring and installation manuals, and manual I56-407, *Guide for Proper Use of System Smoke Detectors*, which provides detailed information on detector spacing, placement, zoning, and special applications. Copies of these manuals are available at no charge from System Sensor.

**NOTICE:** This manual should be left with the owner/user of this equipment.

**IMPORTANT:** The detectors used with these bases must be tested and maintained following NFPA 72 requirements. The detectors used with these bases should be cleaned at least once a year.

General Information

Isolator bases prevent an entire communications loop from being disabled when a short circuit occurs. They accomplish this by isolating that part of the loop containing the

short from the remainder of the circuit. These bases also automatically restore the entire loop when the cause of the short circuit is corrected. In general, up to 25 addressable devices may be isolated between isolator bases. For the purposes of determining the number of devices between isolator bases, one 3251 is equivalent to 12 addressable devices. For example, (13) 2251's and (1) 3251 may be grouped between two isolator bases.

Mounting

The detector base mounts directly to 3 1/2- and 4-inch octagon and 4-inch square boxes, with or without a plaster ring. To mount, remove the decorative ring by rotating it in either direction to unhook the snaps. Then, separate the ring from the base. Install the base on the box, using the screws supplied with the junction box and the appropriate slots in the base. Replace the decorative ring on the base and rotate it in either direction until the ring snaps in place (see Figure 1).

## Installation Guidelines

All wiring must be installed in compliance with all applicable local codes and any special requirements of the local authority having jurisdiction, using the proper wire sizes. The conductors used to connect smoke detectors to control panels and accessory devices should be color-coded to reduce the likelihood of wiring errors. Improper connections can prevent a system from responding properly in the event of a fire.

For signal wiring (the wiring between interconnected detectors), it is recommended that the wire be no smaller than 18 gauge (1.0 square mm). However, wire sizes up to 12 gauge (3.3 square mm) can be used with the base. The use of twisted pair wiring or shielded cable for the power (+ and -) loop is recommended to minimize the effects of electrical interference.

**NOTE:** Detector head power is supplied by terminals 1(+) and 2(-). Therefore, the head will be part of this isolation group.

If shielded cable is used, the shield connection to and from the detector must be continuous by using wire nuts, crimping, or soldering, as appropriate, for a reliable connection.

Alarm system control panels have specifications for allowable loop resistance. Consult the control panel specifications for the total loop resistance allowed before wiring the detector loops.

Check the zone wiring of all bases in the system before installing detectors. This includes checking the wiring for continuity, correct polarity, ground fault testing, and performing a dielectric test.

Figure 1. Mounting base to electrical box:

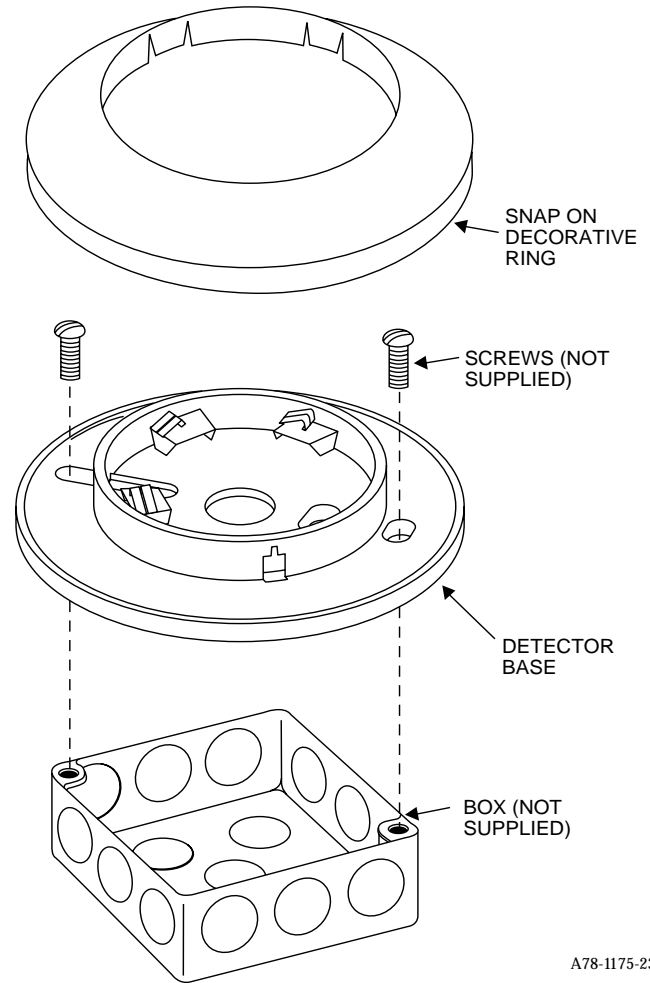

A78-1175-23

Figure 2:

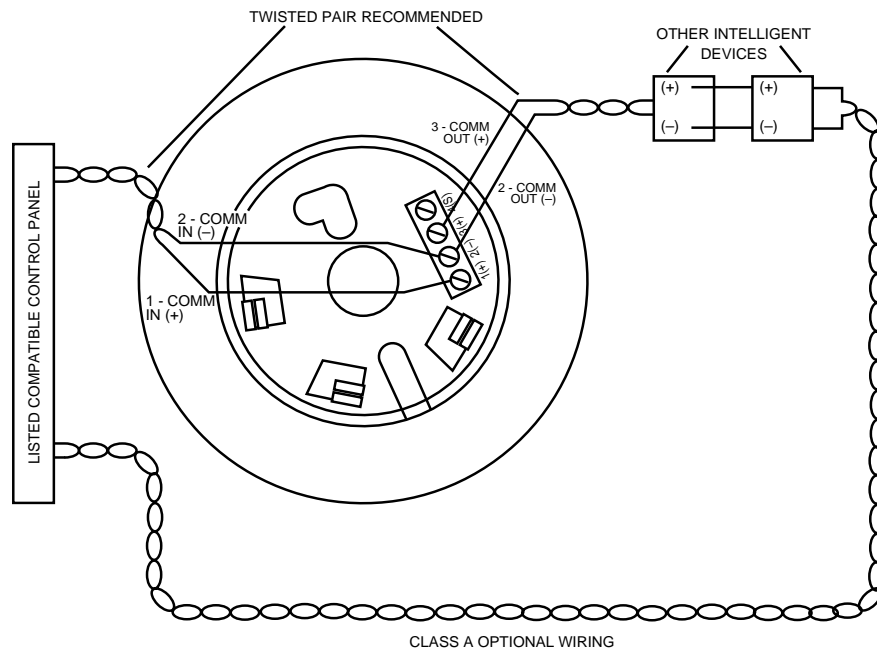

A78-1577-06

Figure 3. Wiring diagram:

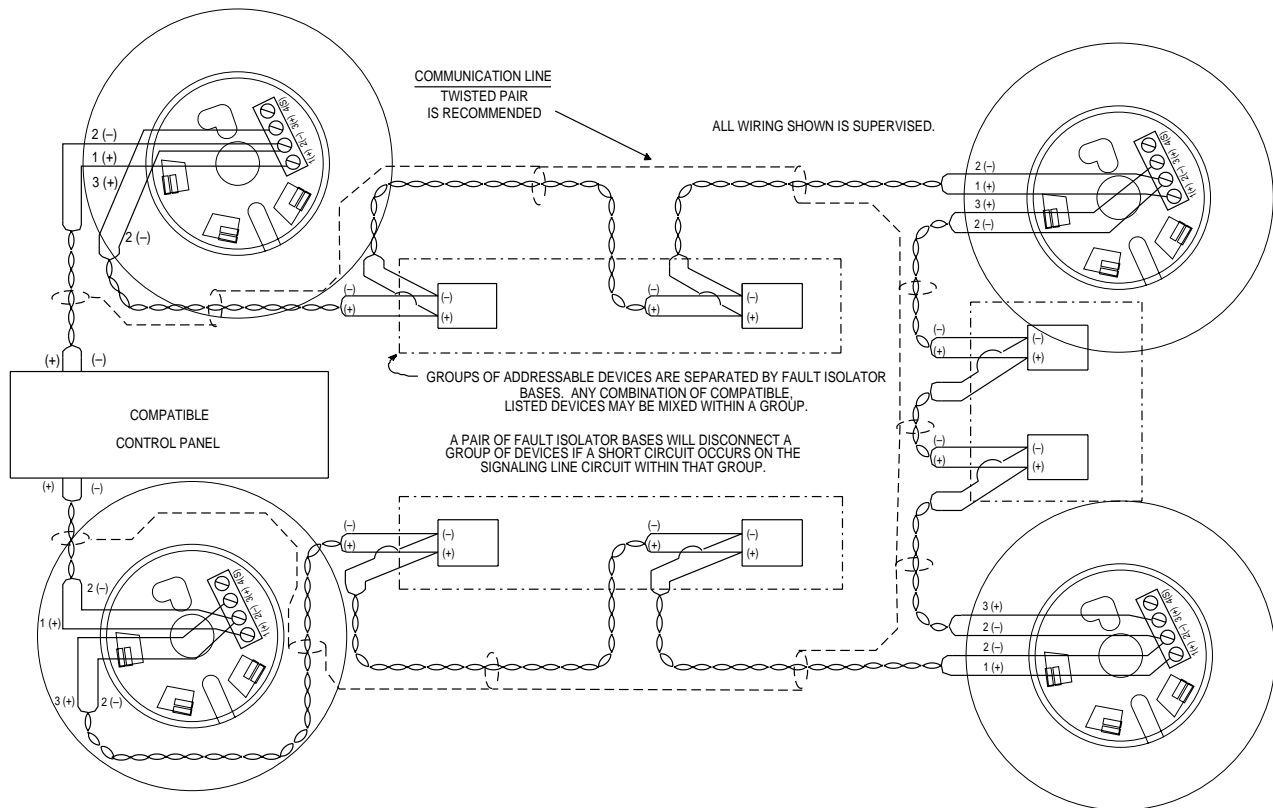

A78-2287-06

### Wiring Instructions

Make wiring connections by stripping about 3/8" (10 mm) of insulation from the wire end. Then, insert the wire into the appropriate terminal and tighten the screw. Wire the communication line in(+) to terminal 1. Insert both communication line in(-) and communication line out(-) to terminal 2. Wire communication line out(+) to terminal 3 (see Figures 2 and 3).

Terminal 4 is for shielded cable only (see Figures 2 and 3). If shielded cable is used, the shield connection to and from the detector must be continuous by using wire nuts, crimping, or soldering to ensure a reliable connection. If shielded cable is NOT used, leave terminal 4 in the screwed-down position.

A label is affixed to the base for recording the zone, address, and type of detector being installed at the base location. This information is useful for setting the detector head address and for verification of the sensor type required for that location.

Once all detector bases have been wired and mounted, and the loop wiring has been checked, the detector heads may be installed in the bases.

### Tamper-resist Feature

**Note:** Do not use the tamper-resist feature if the removal tool is to be used.

This detector base includes a tamper-resist feature that prevents its removal from the base without the use of a tool.

To activate this feature, break the tab from the detector base as shown in Figure 4A (see Page 4). Then, install the detector.

To remove the detector from the base once the tamper-resist feature has been activated, insert a small-bladed screwdriver into the slot in the side of the base and push the plastic lever away from the detector head (see Figure 4B, page 4). This allows the detector to be rotated counter-clockwise for removal.

**Note:** Head removal after the tamper-resist feature has been activated requires removal of the decorative ring.

The tamper-resist feature can be defeated by breaking and removing the plastic lever from the base. However, this prevents the feature from being used again.

Figure 4A. Activating the tamper-resist feature:

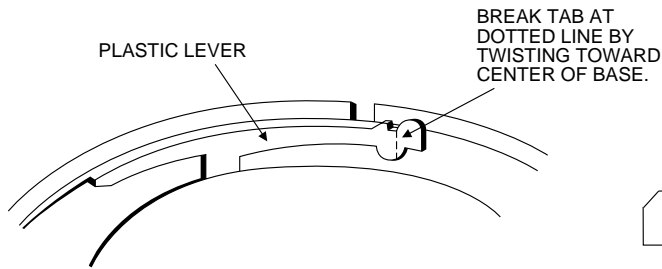
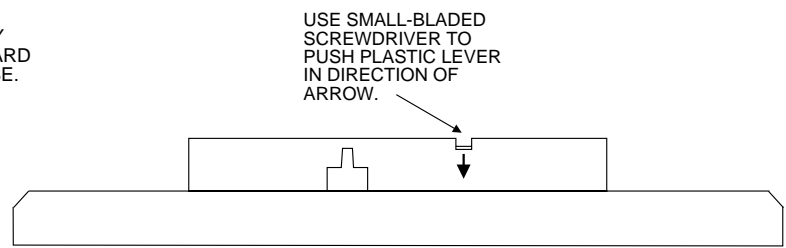

Figure 4B. Removing the detector head from the base:



A78-1175-08

**WARNING**

The Limitations of Property Protection Smoke Detectors

The smoke detector used with this base is designed to **activate and initiate** emergency action, but will do so only when it is used in conjunction with an authorized fire alarm system. This detector must be installed in accordance with NFPA standard 72.

**Smoke detectors will not work without power.** AC or DC powered smoke detectors will not work if the power supply is cut off.

**Smoke detectors will not sense fires which start where smoke does not reach the detectors.** Smoldering fires typically do not generate a lot of heat which is needed to drive the smoke up to the ceiling where the smoke detector is usually located. For this reason, there may be large delays in detecting a smoldering fire with either an ionization type detector or a photoelectric type detector. Either one of them may alarm only after flaming has initiated which will generate the heat needed to drive the smoke to the ceiling.

Smoke from fires in chimneys, in walls, on roofs or on the other side of a closed door(s) may not reach the smoke detector and alarm it. A detector cannot detect a fire developing on another level of a building quickly or at all. For these reasons, detectors **shall be located on every level and in every bedroom within a building.**

**Smoke detectors have sensing limitations, too.** Ionization detectors and photoelectric detectors are required to pass fire tests of the flaming and

smoldering type. This is to ensure that both can detect a wide range of types of fires. Ionization detectors offer a broad range of fire sensing capability but they are somewhat better at detecting fast flaming fires than slow smoldering fires. Photoelectric detectors sense smoldering fires better than flaming fires which have little, if any, visible smoke. Because fires develop in different ways and are often unpredictable in their growth, neither type of detector is always best, and a given detector may not always provide early warning of a specific type of fire.

In general, detectors cannot be expected to provide warnings for fires resulting from inadequate fire protection practices, violent explosions, escaping gases which ignite, improper storage of flammable liquids like cleaning solvents which ignite, other similar safety hazards, arson, smoking in bed, children playing with matches or lighters, etc. Smoke detectors used in high air velocity conditions may have a delay in alarm due to dilution of smoke densities created by frequent and rapid air exchanges. Additionally, high air velocity environments may create increased dust contamination, demanding more frequent maintenance.

**Smoke detectors cannot last forever.** Smoke detectors contain electronic parts. Even though smoke detectors are made to last over 10 years, any part can fail at any time. Therefore, smoke detectors shall be replaced after being in service for 10 years. The smoke detector system that this detector is used in must be tested regularly per NFPA 72. This smoke detector should be cleaned regularly per NFPA 72 or at least once a year.

Three-Year Limited Warranty

System Sensor warrants its enclosed smoke detector base to be free from defects in materials and workmanship under normal use and service for a period of three years from date of manufacture. System Sensor makes no other express warranty for this smoke detector base. No agent, representative, dealer, or employee of the Company has the authority to increase or alter the obligations or limitations of this Warranty. The Company's obligation of this Warranty shall be limited to the repair or replacement of any part of the smoke detector base which is found to be defective in materials or workmanship under normal use and service during the three year period commencing with the date of manufacture. After phoning System Sensor's toll free number 800-SENSOR2 (736-7672) for a Return Authorization number, send defective units postage prepaid to: System Sensor,

Repair Department, RA # \_\_\_\_\_, 3825 Ohio Avenue, St. Charles, IL 60174. Please include a note describing the malfunction and suspected cause of failure. The Company shall not be obligated to repair or replace units which are found to be defective because of damage, unreasonable use, modifications, or alterations occurring after the date of manufacture. In no case shall the Company be liable for any consequential or incidental damages for breach of this or any other Warranty, expressed or implied whatsoever, even if the loss or damage is caused by the Company's negligence or fault. Some states do not allow the exclusion or limitation of incidental or consequential damages, so the above limitation or exclusion may not apply to you. This Warranty gives you specific legal rights, and you may also have other rights which vary from state to state.