

## Installation manual



## SmartDrive HVAC

Heating, Ventilation and  
Air conditioning applications



**INDEX**

Document: DPD00487E  
Version release date: 5.12.13

<b>1. Safety</b> .....	<b>2</b>
1.1 Danger .....	2
1.2 Warnings .....	3
1.3 Earthing and earth fault protection .....	3
1.4 EMC levels .....	4
1.4.1 Total Harmonic Distortion (THD) .....	5
<b>2. Receipt of delivery</b> .....	<b>6</b>
2.1 Type designation code .....	7
2.2 Unpacking and lifting the drive .....	8
2.2.1 Lifting frames MR8 and MR9 .....	8
2.3 Accessories .....	10
2.3.1 Size MR4 .....	10
2.3.2 Size MR5 .....	10
2.3.3 Size MR6 .....	11
2.3.4 Size MR7 .....	11
2.3.5 Size MR8 .....	12
2.3.6 Size MR9 .....	12
2.4 'Product modified' sticker .....	13
<b>3. Mounting</b> .....	<b>14</b>
3.1 Dimensions .....	14
3.2 Cooling .....	18
<b>4. Power cabling</b> .....	<b>20</b>
4.1 UL standards on cabling .....	21
4.1.1 Cable dimensioning and selection .....	21
4.2 Cable installation .....	26
4.2.1 Frames MR4 to MR7 .....	27
4.2.2 Frames MR8 and MR9 .....	33
4.3 Installation in corner-grounded network .....	43
<b>5. Control unit</b> .....	<b>44</b>
5.1 Control unit cabling .....	45
5.1.1 Control cable sizing .....	45
5.1.2 Control terminals and DIP switches .....	46
5.2 I/O cabling and fieldbus connection .....	49
5.2.1 Prepare for use through Ethernet .....	49
5.2.2 Prepare for use through MS/TP .....	51
5.2.3 RS485 cable data .....	55
5.3 Changing the battery for Real Time Clock (RTC) .....	56
5.4 Galvanic isolation barriers .....	57
<b>6. Commissioning</b> .....	<b>58</b>
6.1 Commissioning of the drive .....	59
6.2 Running the motor .....	59
6.2.1 Cable and motor insulation checks .....	59
6.3 Installation in IT system .....	61
6.3.1 Frames MR4 to MR6 .....	61
6.3.2 Frames MR7 and MR8 .....	63
6.3.3 Frame MR9 .....	64

6.4	Maintenance .....	66
<b>7.</b>	<b>Technical data .....</b>	<b>67</b>
7.1	Drive power ratings .....	67
7.1.1	Mains voltage 208-240 V .....	67
7.1.2	Mains voltage 380-480 V .....	68
7.1.3	Definitions of overloadability .....	69
7.2	Technical data .....	70
7.2.1	Technical information on control connections .....	73

# 1. SAFETY

This manual contains clearly marked cautions and warnings which are intended for your personal safety and to avoid any unintentional damage to the product or connected appliances.

**Please read the information included in cautions and warnings carefully.**

The cautions and warnings are marked as follows:



	= <b>DANGEROUS VOLTAGE!</b>
	= <b>WARNING or CAUTION</b>

Table 1. Warning signs

## 1.1 Danger



The **components of the power unit of the drive are live** when the drive is connected to mains potential. Coming into contact with this voltage is **extremely dangerous** and may cause death or severe injury.



The **motor terminals U, V, W and the brake resistor terminals are live** when the drive is connected to mains, even if the motor is not running.



**After disconnecting** the drive from the mains, **wait** until the indicators on the keypad go out (if no keypad is attached see the indicators on the cover). Wait 5 more minutes before doing any work on the connections of the drive. Do not open the cover before this time has expired. After expiration of this time, use a measuring equipment to absolutely ensure that no voltage is present. **Always ensure absence of voltage before starting any electrical work!**



The control I/O-terminals are isolated from the mains potential. However, the **relay outputs and other I/O-terminals may have a dangerous control voltage** present even when the drive is disconnected from mains.



**Before connecting** the drive to mains make sure that the front and cable covers of the drive are closed.



During a coast stop (see the Application Manual), the motor is still generating voltage to the drive. Therefore, do not touch the components of the drive before the motor has completely stopped. Wait until the indicators on the keypad go out (if no keypad is attached see the indicators on the cover). Wait additional 5 minutes before starting any work on the drive.

## 1.2 Warnings



The drive is meant for **fixed installations only**.



**Do not perform any measurements** when the drive is connected to the mains.



The **touch current** of the drives exceeds 3.5mA AC. According to standard EN61800-5-1, a **reinforced protective ground connection** must be ensured. See chapter 1.3.



Corner grounding is allowed for the drive types with the ratings from 72 A to 310 A at 380...480 V supply and from 75 A to 310 A at 208...240 V supply. Remember to change the EMC level by removing the jumpers. See chapter 6.3.



If the drive is used as a part of a machine, the **machine manufacturer is responsible** for providing the machine with a **supply disconnecting device** (EN 60204-1).



Only **spare parts** delivered by Honeywell can be used.



At power-up, power brake or fault reset **the motor will start immediately** if the start signal is active, unless the pulse control for Start/Stop logic has been selected.

Futhermore, the I/O functionalities (including start inputs) may change if parameters, applications or software are changed. Disconnect, therefore, the motor if an unexpected start can cause danger.



The **motor starts automatically** after automatic fault reset if the autoreset function is activated. See the Application Manual for more detailed information.



**Prior to measurements on the motor or the motor cable**, disconnect the motor cable from the drive.



**Do not touch the components on the circuit boards**. Static voltage discharge may damage the components.



Check that the **EMC level** of the drive corresponds to the requirements of your supply network. See chapter 6.3.



In a domestic environment, this product may cause radio interference in which case supplementary mitigation measures may be required.

## 1.3 Earthing and earth fault protection



### CAUTION!

The drive must always be earthed with an earthing conductor connected to the earthing terminal marked with .

The touch current of the drive exceeds 3.5mA AC. According to EN61800-5-1, one or more of the following conditions for the associated protective circuit shall be satisfied:

A fixed connection and

- a) the **protective earthing conductor** shall have a cross-sectional area of at least 10 mm<sup>2</sup> Cu or 16 mm<sup>2</sup> Al.
- or
- b) an automatic disconnection of the supply in case of discontinuity of the protective earthing conductor. See chapter 4.
- or
- c) provision of an additional terminal for a second **protective earthing conductor** of the same cross-sectional area as the original **protective earthing conductor**.

Cross-sectional area of phase conductors (S) [mm <sup>2</sup> ]	Minimum cross-sectional area of the corresponding <b>protective earthing conductor</b> [mm <sup>2</sup> ]
$S \leq 16$	S
$16 < S \leq 35$	16
$35 < S$	S/2

The values above are valid only if the protective earthing conductor is made of the same metal as the phase conductors. If this is not so, the cross-sectional area of the protective earthing conductor shall be determined in a manner which produces a conductance equivalent to that which results from the application of this table.

Table 2. Protective earthing conductor cross-section

The cross-sectional area of every protective earthing conductor which does not form a part of the supply cable or cable enclosure shall, in any case, be not less than

- 2.5 mm<sup>2</sup> if mechanical protection is provided or
- 4 mm<sup>2</sup> if mechanical protection is not provided. For cord-connected equipment, provisions shall be made so that the protective earthing conductor in the cord shall, in the case of failure of the strain-relief mechanism, be the last conductor to be interrupted.

**However, always follow the local regulations for the minimum size of the protective earthing conductor.**

**NOTE:** Due to the high capacitive currents present in the drive, fault current protective switches may not function properly.



**Do not perform any voltage withstand tests** on any part of the drive. There is a certain procedure according to which the tests shall be performed. Ignoring this procedure may result in damaged product.

## 1.4 EMC levels

SmartDrive HVAC inverters are divided into three classes according to the level of electromagnetic disturbances emitted, the requirements of a power system network and the installation environment (see below). The EMC class of each product is defined in the type designation code.

**Category C1 (Honeywell EMC class C):** Inverters of this class comply with the requirements of category C1 of the product standard EN 61800-3 (2004). Category C1 ensures the best EMC

characteristics and it includes converters the rated voltage of which is less than 1000V and which are intended for use in the 1st environment. This EMC class is meant for highly sensitive areas and can be sometimes required in installations in e.g. hospitals or airport control towers. **NOTE:** The requirements of class C1 are fulfilled only as far as the conducted emissions are concerned with an external EMC-filter. The Honeywell C1 EMC filters are listed under the reference RFI-xxxx-x-xxxx.

**Category C2 (Honeywell EMC class H):** All Honeywell SmartDrive HVAC inverters comply with the requirements of category C2 of the product standard EN 61800-3 (2004). Category C2 includes converters in fixed installations and the rated voltage of which is less than 1000V. The category C2 inverters can be used both in the 1st and the 2nd environment. This category fulfills the requirements with normal installations in buildings.

**IT networks (Honeywell EMC class T):** Inverters of this class fulfil the product standard EN 61800-3 (2004) if intended to be used in IT systems. In IT systems, the networks are isolated from earth, or connected to earth through high impedance to achieve a low leakage current. **NOTE:** if inverters configured to IT network are used with other supplies, no EMC requirements are complied with. SmartDrive HVAC inverters can be easily modified to the requirements of the T-class. This class is very typical requirement also in installations in ships. Also the 230V SmartDrive HVAC products can be ordered as ready configured to this class by adding a T to the end of standard product code (HVAC230-xxx-xxT).

*Environments in product standard EN 61800-3 (2004):*

**First environment:** Environment that includes domestic premises. It also includes establishments directly connected without intermediate transformers to a low-voltage power supply network which supplies buildings used for domestic purposes.

**NOTE:** houses, apartments, commercial premises or offices in a residential building are examples of first environment locations.

**Second environment:** Environment that includes all establishments other than those directly connected to a low-voltage power supply network which supplies buildings used for domestic purposes.

**NOTE:** industrial areas, technical areas of any building fed from a dedicated transformer are examples of second environment locations.

#### 1.4.1 Total Harmonic Distortion (THD)

This equipment complies with IEC 61000-3-12 provided that the short-circuit power  $S_{SC}$  is greater than or equal to 120 at the interface point between the user's supply and the public system. It is the responsibility of the installer or user of the equipment to ensure, by consultation with the distribution network operator if necessary, that the equipment is connected only to a supply with a short-circuit power  $S_{SC}$  greater than or equal to 120.

**NOTE!** You can download the English and French product manuals with applicable safety, warning and caution information from <https://customer.honeywell.com/en-US/Pages/default.aspx>.

**REMARQUE** Vous pouvez télécharger les versions anglaise et française des manuels produit contenant l'ensemble des informations de sécurité, avertissements et mises en garde applicables sur le site <https://customer.honeywell.com/en-US/Pages/default.aspx>.



## 2. RECEIPT OF DELIVERY

Check the correctness of delivery by comparing your order data to the drive information found on the package label. If the delivery does not correspond to your order, contact the supplier immediately. See chapter 2.3.

Date code (batch ID):yyww

Product type: —————>



Product serial  
number —————>

Electrical data and  
enclosure class —————>

**AC DRIVE**      **B.ID:** 11211      **0020453955**

**Type:** HVAC230-2P2-54

**S/N:** V00000051263



**Code:** 

**Made in Finland**

**Input:** Uin:3~AC,208-240V, 50/60, 11A

**Output:** 3~AC,0-Uin, 0-320Hz, 11A

**Power:** 2.2kW:230V / 3.0HP:230V  
IP54/Type12

POWER CONVERSION EQUIPMENT

**Variable Frequency Drive**

**HONEYWELL GMBH - SCHOENAICH**

# Honeywell

D-71101 Schönaich      <http://ecc.emea.honeywell.com>

9182.emf

## 2.1 Type designation code

Honeywell type designation code is formed of a four-segment code. Each segment of the type designation code uniquely corresponds to the product and options you have ordered. The code is of the following format:

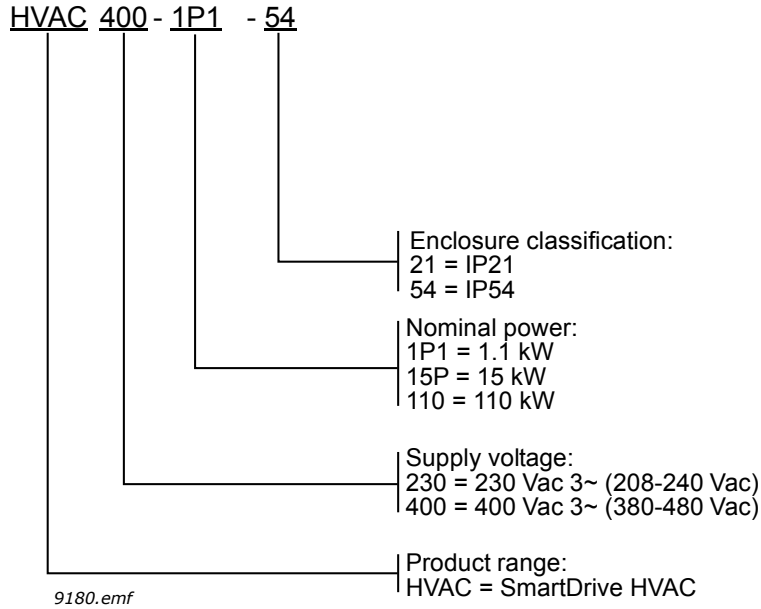

Figure 1. Type designation code

### Special versions

Table 3. Special versions

ID	Description	Note
A	Product delivered with advanced commissioning keypad instead of standard text keypad	Available only with 400V products (HVAC400-xxx-xxA)
S	Models with integrated load switch	Available only with IP54 400V products (HVAC400-xxx-54S)
T	Configured ready for the requirements of IT-network and including the advanced commissioning keypad instead of standard text keypad	Available only with 230V products (HVAC230-xxx-xxT)

## 2.2 Unpacking and lifting the drive

The weights of the drives vary greatly according to the size. You may need to use a piece of special lifting equipment to move the converter from its package. Note the weights of each individual frame size in Table 4 below.

Frame	Nominal power 400V 3~ series	Nominal power 230V 3~ series	Weight [kg]
MR4	1.1 - 5.5 kW	0.55 - 3.0 kW	6.0
MR5	7.5 - 15.0 kW	4.0 - 7.5 kW	10.0
MR6	18.5 - 30.0 kW	11.0 - 15.0 kW	20.0
MR7	37.0 - 55.0 kW	18.5 - 30.0 kW	37.5
MR8	75.0 - 110 kW	37.0 - 55.0 kW	70.0
MR9	132 - 160 kW	75.0 - 90.0 kW	108.0

Table 4. Frame weights

If you decide to use a piece of lifting equipment see picture below for recommendations to lift the drive.

### 2.2.1 Lifting frames MR8 and MR9

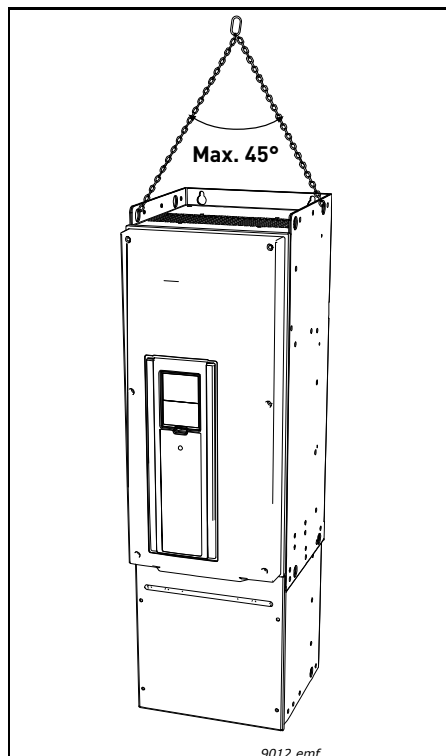

**NOTE:** First detach the drive from the pallet it has been bolted to.

**NOTE:** Place the lifting hooks symmetrically in at least two holes. The lifting device must be able to carry weight of the drive.

**NOTE:** The maximum allowed lifting angle is 45 degrees.

Figure 2. Lifting bigger frames

The drives have undergone scrupulous tests and quality checks at the factory before they are delivered to the customer. However, after unpacking the product, check that no signs of transport damages are to be found on the product and that the delivery is complete.

Should the drive have been damaged during the shipping, please contact primarily the cargo insurance company or the carrier.

## 2.3 Accessories

After having opened the transport package and lifted the converter out, check immediately that these various accessories were included in the delivery. The contents of the accessories bag differ by drive size and IP protections class:

### 2.3.1 Size MR4

Item	Quantity	Purpose
M4x16 screw	11	Screws for power cable clamps (6), control cable clamps (3), grounding clamps (2)
M4x8 screw	1	Screw for optional grounding
M5x12 screw	1	Screw for drive external grounding
Control cable grounding lamella	3	Control cable grounding
EMC cable clamps, size M25	3	Clamping power cables
Grounding clamp	2	Power cable grounding
'Product modified' label	1	Information about modifications
IP21: Cable grommet	3	Cable run-through sealing
IP54: Cable grommet	6	Cable run-through sealing

Table 5. Contents of accessories bag, MR4

### 2.3.2 Size MR5

Item	Quantity	Purpose
M4x16 screw	13	Screws for power cable clamps (6), control cable clamps (3), grounding clamps (4)
M4x8 screw	1	Screw for optional grounding
M5x12 screw	1	Screw for drive external grounding
Control cable grounding lamella	3	Control cable grounding
EMC cable clamps, size M25	1	Clamping brake resistor cable
EMC cable clamps, size M32	2	Clamping power cables
Grounding clamp	2	Power cable grounding
'Product modified' label	1	Information about modifications
IP21: Cable grommet, hole diameter 25.3 mm	1	Cable run-through sealing
IP54: Cable grommet, hole diameter 25.3 mm	4	Cable run-through sealing
Cable grommet, hole diameter 33.0 mm	2	Cable run-through sealing

Table 6. Contents of accessories bag, MR5

**2.3.3 Size MR6**

Item	Quantity	Purpose
M4x20 screw	10	Screws for power cable clamps (6) and grounding clamps (4)
M4x16 screw	3	Screws for control cable clamps
M4x8 screw	1	Screw for optional grounding
M5x12 screw	1	Screw for drive external grounding
Control cable grounding lamella	3	Control cable grounding
EMC cable clamps, size M32	1	Clamping brake resistor cable
EMC cable clamps, size M40	2	Clamping power cables
Grounding clamp	2	Power cable grounding
'Product modified' label	1	Information about modifications
Cable grommet, hole diameter 33.0 mm	1	Cable run-through sealing
Cable grommet, hole diameter 40.3 mm	2	Cable run-through sealing
IP54: Cable grommet, hole diameter 25.3 mm	3	Cable run-through sealing

*Table 7. Contents of accessories bag, MR6*

**2.3.4 Size MR7**

Item	Quantity	Purpose
M5x30 slotted nut	6	Nuts for power cable clamps
M4x16 screw	3	Screws for control cable clamps
M6x12 screw	1	Screw for drive external grounding
Control cable grounding lamella	3	Control cable grounding
EMC cable clamps, size M50	3	Clamping power cables
Grounding clamp	2	Power cable grounding
'Product modified' label	1	Information about modifications
Cable grommet, hole diameter 50.3 mm	3	Cable run-through sealing
IP54: Cable grommet, hole diameter 25.3 mm	3	Cable run-through sealing

*Table 8. Contents of accessories bag, MR7*

**2.3.5 Size MR8**

Item	Quantity	Purpose
M4x16 screw	3	Screws for control cable clamps
Control cable grounding lamella	3	Control cable grounding
Cable lugs KP34	3	Clamping power cables
Cable insulator	11	Avoiding contact between cables
Cable grommet, hole diameter 25.3 mm	4	Control cable run-through sealing
IP00: Touch protection shield	1	Avoiding contact with live parts
IP00: M4x8 screw	2	Fixing the touch protection shield

*Table 9. Contents of accessories bag, MR8***2.3.6 Size MR9**

Item	Quantity	Purpose
M4x16 screw	3	Screws for control cable clamps
Control cable grounding lamella	3	Control cable grounding
Cable lugs KP40	5	Clamping power cables
Cable insulator	10	Avoiding contact between cables
Cable grommet, hole diameter 25.3 mm	4	Control cable run-through sealing
IP00: Touch protection shield	1	Avoiding contact with live parts
IP00: M4x8 screw	2	Fixing the touch protection shield

*Table 10. Contents of accessories bag, MR9*

**2.4 'Product modified' sticker**

In the small plastic bag included in the delivery you will find a silver *Product modified* sticker. The purpose of the sticker is to notify the service personnel about the modifications made in the drive. Attach the sticker on the side of the drive to avoid losing it. Should the drive be later modified mark the change on the sticker.

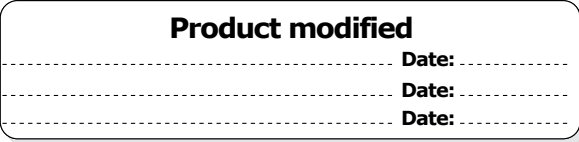

*Figure 3. 'Product modified' sticker*



### 3. MOUNTING

The drive must be mounted in vertical position on the wall or on the back plane of a cubicle. Ensure that the mounting plane is relatively even.

The drive shall be fixed with four screws (or bolts, depending on the unit size).

#### 3.1 Dimensions

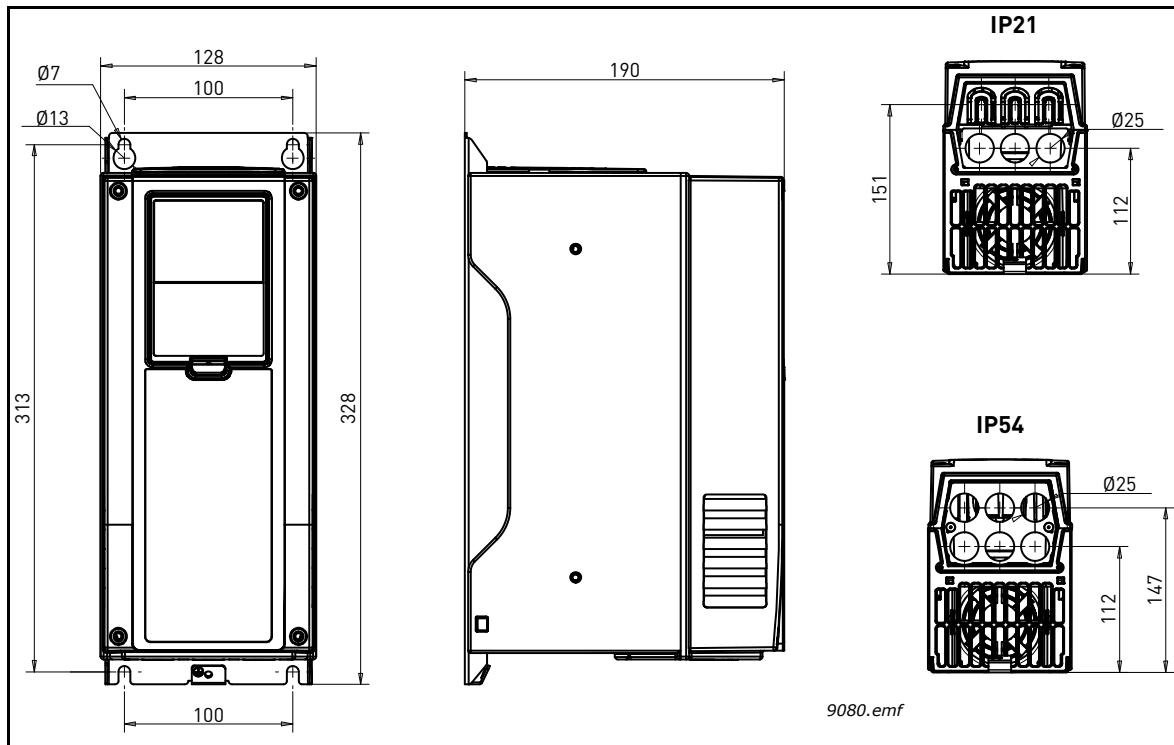

Figure 4. SmartDrive dimensions, MR4

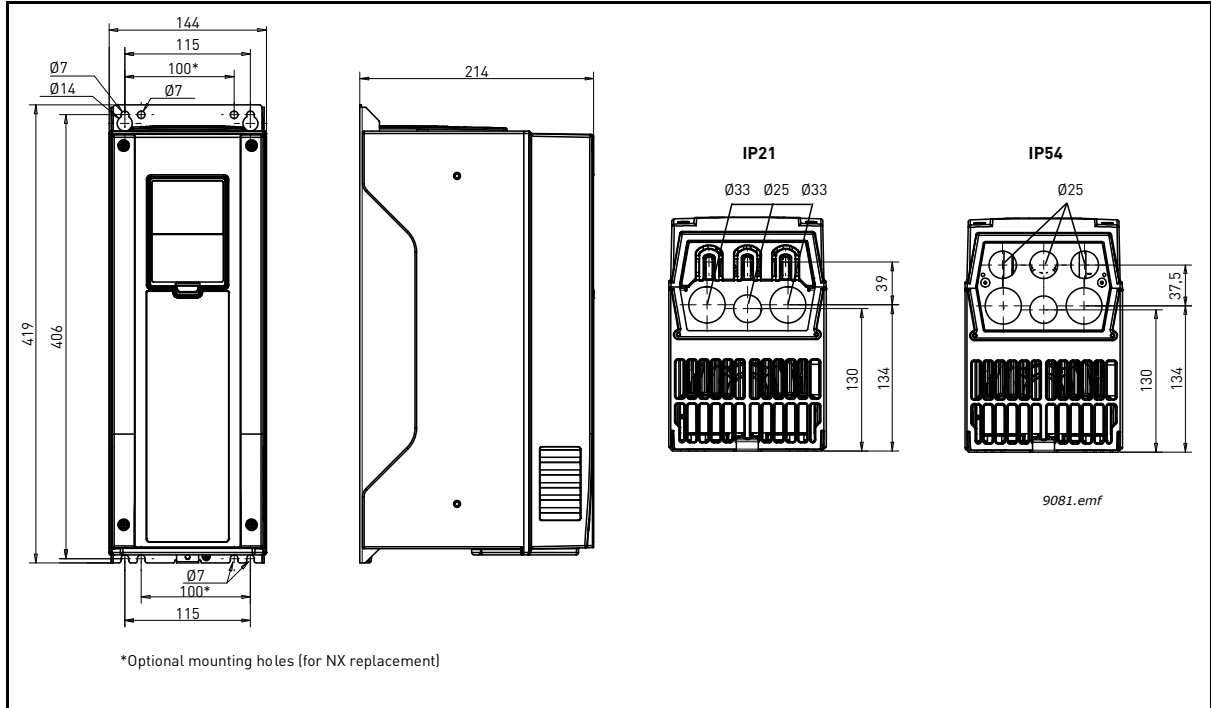

Figure 5. SmartDrive dimensions, MR5

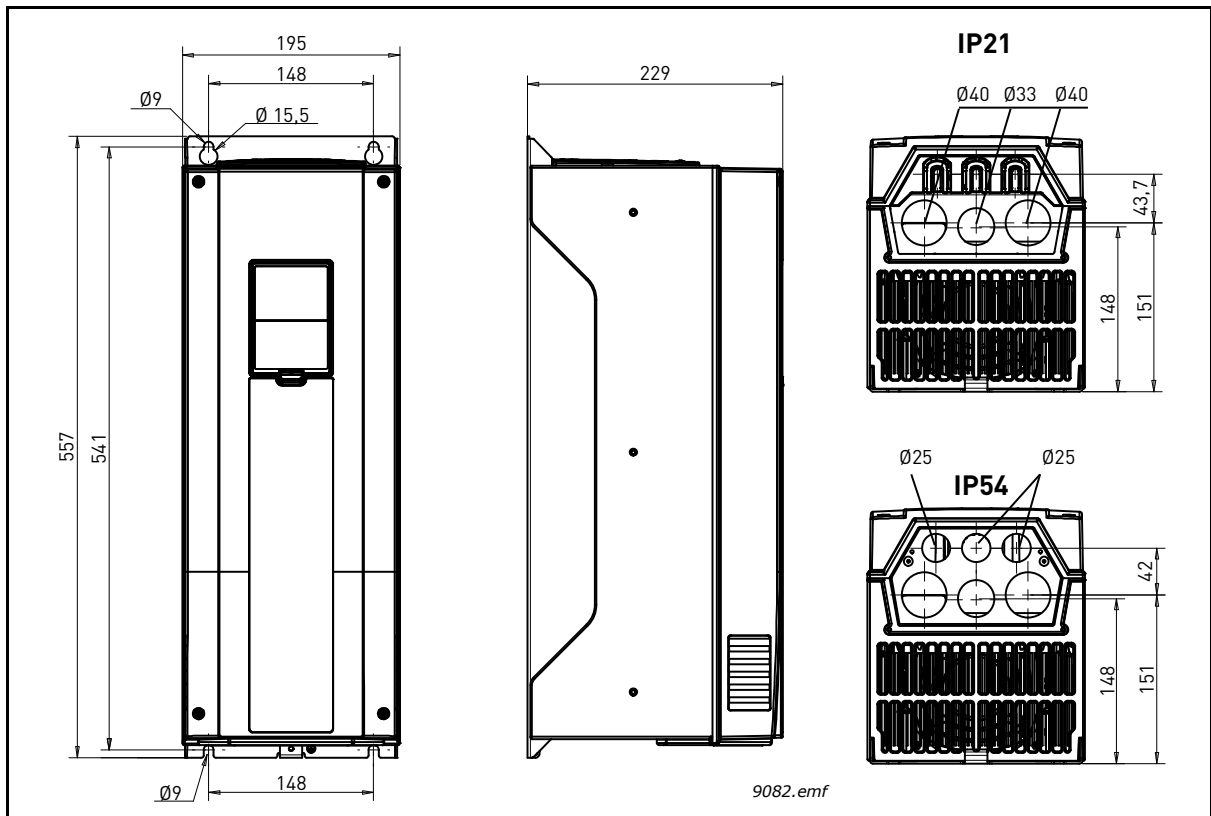

Figure 6. SmartDrive dimensions, MR6

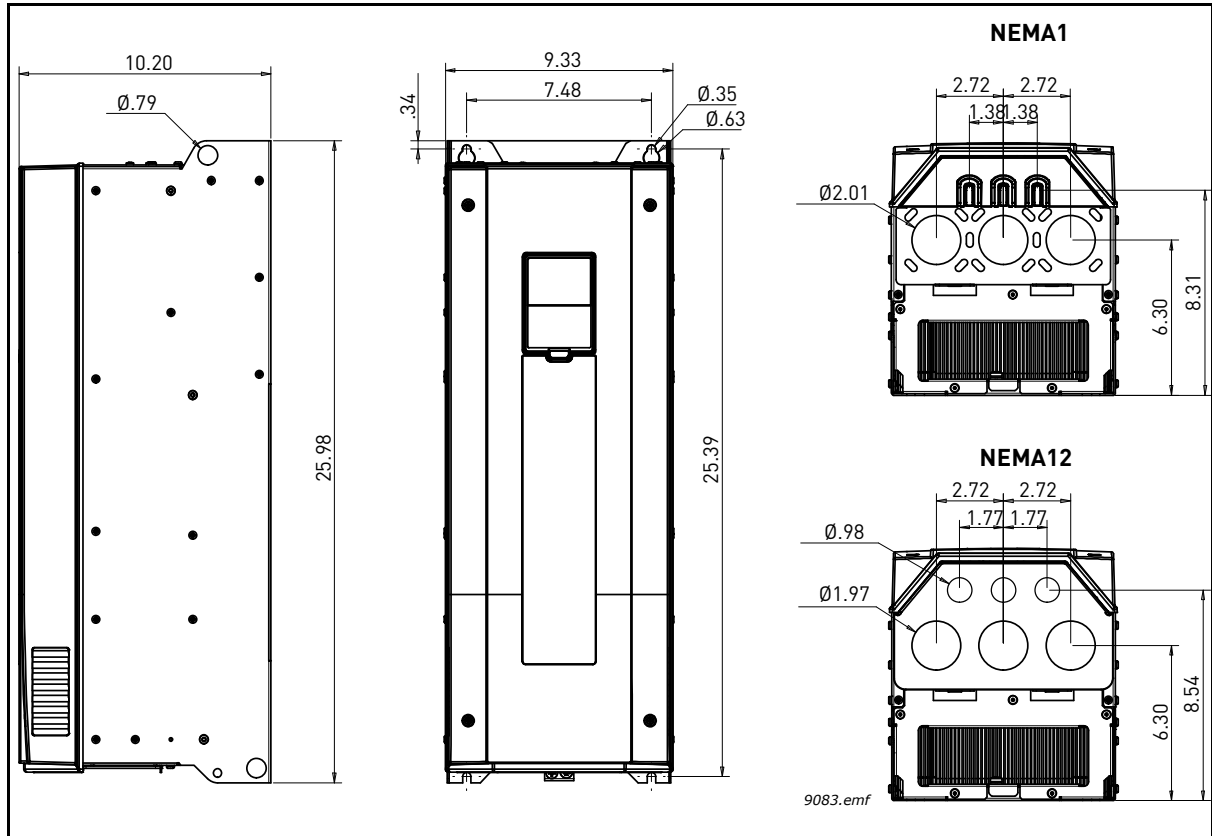

Figure 7. SmartDrive dimensions, MR7

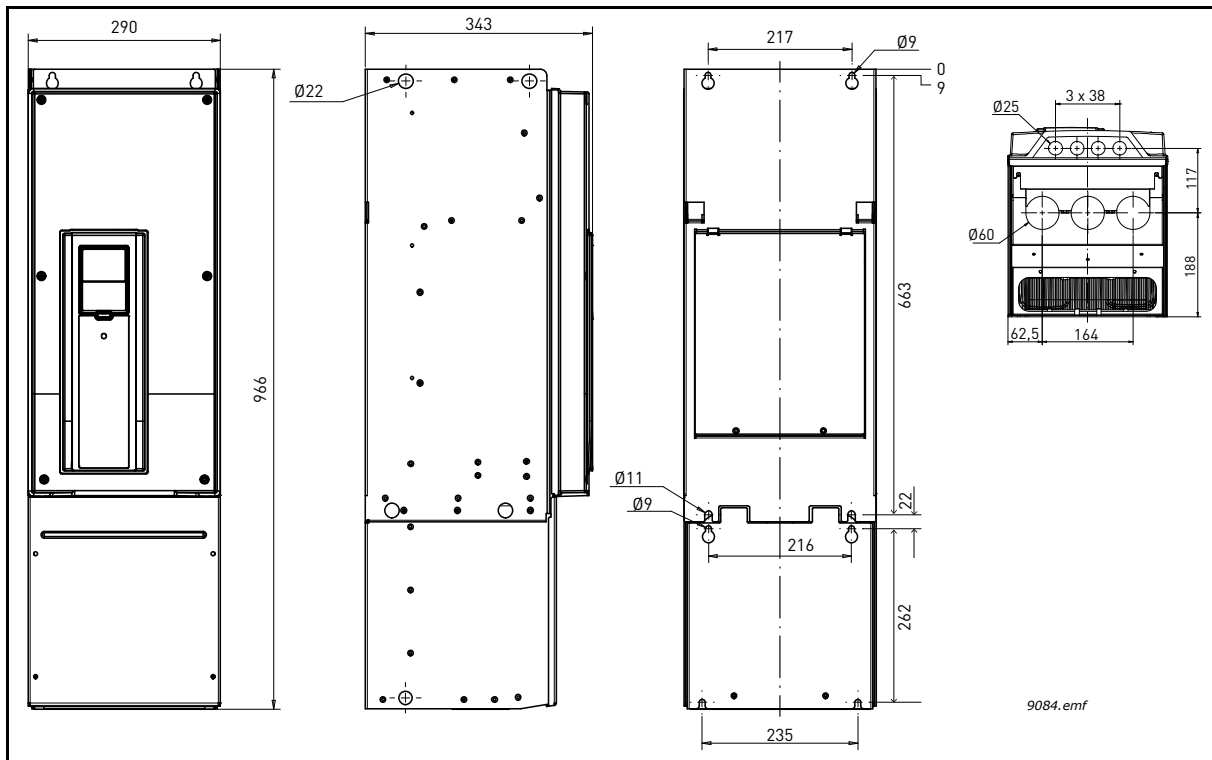

Figure 8. SmartDrive dimensions, MR8 IP21 and IP54

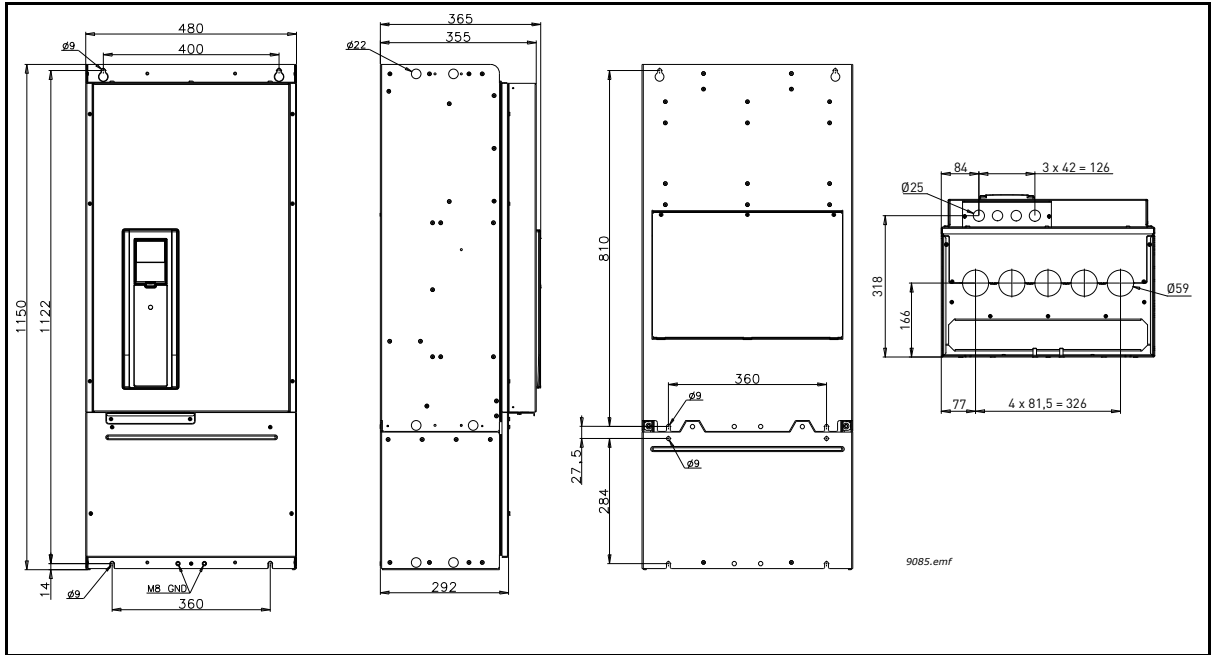
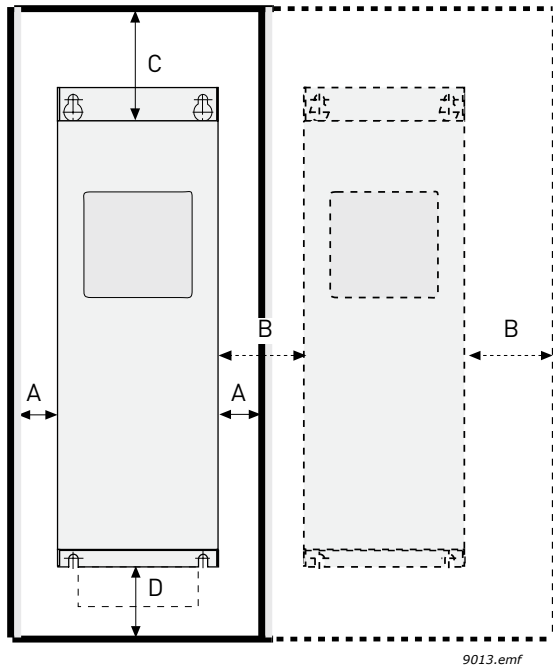

Figure 9. SmartDrive dimensions, MR9 IP21 and IP54

### 3.2 Cooling

The drives produce heat in operation and are cooled down by air circulated by a fan. Enough free space shall therefore be left around the drive to ensure sufficient air circulation and cooling. Different acts of maintenance also require certain amount of free space.

Make sure that the temperature of the cooling air does not exceed the maximum ambient temperature of the converter.



Min clearance [mm]				
Type	A*	B*	C	D
MR4	20	20	100	50
MR5	20	20	120	60
MR6	20	20	160	80
MR7	20	20	250	100
MR8	20	20	300	150
MR9	20	20	350	200

\*. Min clearances A and B for drives with IP54 enclosure is 0 mm.

Table 11. Min. clearances around drive

Figure 10. Installation space

- A = clearance around the freq. converter (see also B)
- B = distance from one drive to another or distance to cabinet wall
- C = free space above the drive
- D = free space underneath the drive

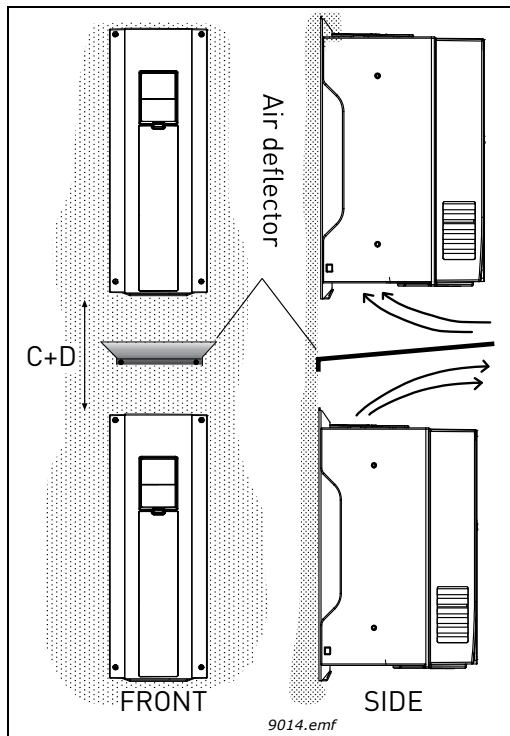

Note that if several units are mounted above each other the required free space equals C + D (see Figure 11.). Moreover, the outlet air used for cooling by the lower unit must be directed away from the air intake of the upper unit by means of e.g. a piece of metal plate fixed to cabinet wall between the drives as shown in Figure 11.

Figure 11. Installation space when drives are mounted on top of each other

Type	Cooling air required [m <sup>3</sup> /h]
MR4	45
MR5	75
MR6	190
MR7	185
MR8	335
MR9	621

Table 12. Required cooling air

## 4. POWER CABLING

The mains cables are connected to terminals L1, L2 and L3 and the motor cables to terminals marked with U, V and W. See principal connection diagram in Figure 12. See also Table 13 for the cable recommendations for different EMC levels.

If the motor cables cannot be installed according to the written requirements, the installation of a sine filter near the inverter is recommended.

The Honeywell sine filters are listed under the reference SIN-xxxx-5-0-P.

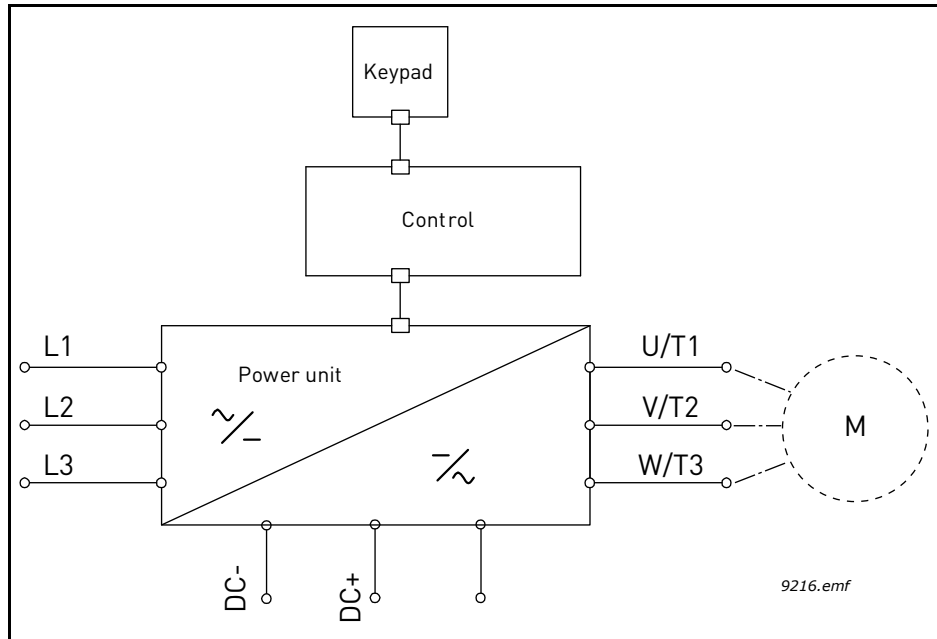

Figure 12. Principal connection diagram

Use cables with heat resistance of at least +70°C. The cables and the fuses must be dimensioned according to the drive nominal OUTPUT current which you can find on the rating plate.

Cable type	EMC levels According to EN61800-3 (2004)		
	1 <sup>st</sup> environment	2 <sup>nd</sup> environment	
	Category C2	Category C3	Level C4
Mains cable	1	1	1
Motor cable	3*	2	2
Control cable	4	4	4

Table 13. Cable types required to meet standards

1 = Power cable intended for fixed installation and the specific mains voltage. Shielded cable not required. (MCMK or similar recommended).

2 = Symmetrical power cable equipped with concentric protection wire and intended for the specific mains voltage. (MCMK or similar recommended). See Figure 13.

- 3 = Symmetrical power cable equipped with compact low-impedance shield and intended for the specific mains voltage. [MCCMK, EMCMK or similar recommended; Recommended cable transfer impedance (1...30MHz) max. 100mohm/m]. See Figure 13.  
 \*360° earthing of the shield with cable glands in motor end needed for EMC level C2.
- 4 = Screened cable equipped with compact low-impedance shield (JAMAK, SAB/ÖZCuY-O or similar).

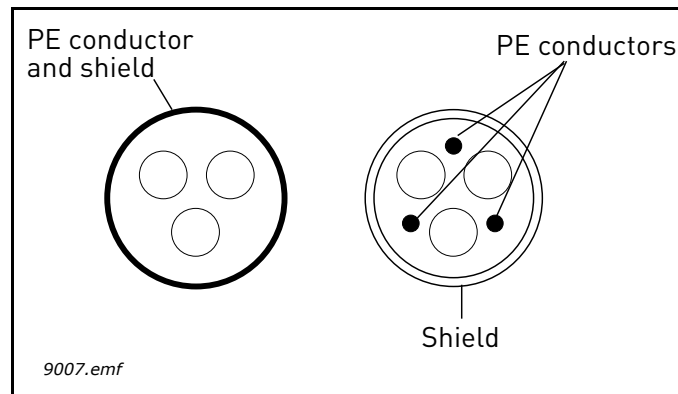

Figure 13.

**NOTE:** The EMC requirements are fulfilled at factory defaults of switching frequencies (all frames).

**NOTE:** If safety switch is connected the EMC protection shall be continuous over the whole cable installation.

#### 4.1 UL standards on cabling

To meet the UL (Underwriters Laboratories) regulations, use a UL-approved copper cable with a minimum heat-resistance of +60/75°C. Use Class 1 wire only.

The units are suitable for use on a circuit capable of delivering not more than 100,000 rms symmetrical amperes, 600V maximum.

##### 4.1.1 Cable dimensioning and selection

Table 14 shows the minimum dimensions of the Cu/Al-cables and the corresponding fuse sizes. Recommended fuse types are gG/gL.

These instructions apply only to cases with one motor and one cable connection from the drive to the motor. In any other case, ask the factory for more information.



#### 4.1.1.1 Cable and fuse sizes, frames MR4 to MR6

The recommended fuse types are gG/gL (IEC 60269-1) or class T (UL & CSA). The fuse voltage rating should be selected according to the supply network. The final selection should be made according to local regulations, cable installation conditions and cable specification. Bigger fuses than what is recommended below shall not be used.

Check that the fuse operating time is less than 0.4 seconds. Operating time depends on used fuse type and impedance of the supply circuit. Consult the factory about faster fuses. Honeywell offers recommendations also for high speed J (UL & CSA), aR (UL recognized, IEC 60269-4) and gS (IEC 60269-4) fuse ranges.

Frame	Type	$I_L$ [A]	Fuse (gG/gL) [A]	Mains and motor cable Cu [mm <sup>2</sup> ]	Terminal cable size	
					Main terminal [mm <sup>2</sup> ]	Earth terminal [mm <sup>2</sup> ]
MR4	230 P55—230 P75 400 1P1—400 1P5	3.7—4.8 3.4—4.8	6	3*1.5+1.5	1—6 solid 1—4 stranded	1—6
	230 1P1—230 1P5 400 2P2—400 3P0	6.6—8.0 5.6—8.0	10	3*1.5+1.5	1—6 solid 1—4 stranded	1—6
	230 2P2—230 3P0 400 4P0—400 5P5	11—12.5 9.6—12.0	16	3*2.5+2.5	1—6 solid 1—4 stranded	1—6
MR5	230 4P0 400 7P5	18.0 16.0	20	3*6+6	1—10 Cu	1—10
	230 5P5 400 11P	24.0 23.0	25	3*6+6	1—10 Cu	1—10
	230 7P5 400 15P	31.0	32	3*10+10	1—10 Cu	1—10
MR6	400 18P	38.0	40	3*10+10	2.5—50 Cu/Al	2.5—35
	230 11P 400 22P	48.0 46.0	50	3*16+16 (Cu) 3*25+16 (Al)	2.5—50 Cu/Al	2.5—35
	230 15P 400 30P	62.0 61.0	63	3*25+16 (Cu) 3*35+10 (Al)	2.5—50 Cu/Al	2.5—35

Table 14. Cable and fuse sizes (MR4 to MR6)

The cable dimensioning is based on the criteria of the International Standard IEC60364-5-52: Cables must be PVC-isolated; Max ambient temperature +30°C, max temperature of cable surface +70°C; Use only cables with concentric copper shield; Max number of parallel cables is 9.

When using cables in parallel, **NOTE HOWEVER** that the requirements of both the cross-sectional area and the max number of cables must be observed.

For important information on the requirements of the earthing conductor, see chapter Earthing and earth fault protection of the standard.

For the correction factors for each temperature, see International Standard IEC60364-5-52.

#### 4.1.1.2 Cable and fuse sizes, frames MR7 to MR9

The recommended fuse types are gG/gL (IEC 60269-1) or class T (UL & CSA). The fuse voltage rating should be selected according to the supply network. The final selection should be made according to local regulations, cable installation conditions and cable specification. Bigger fuses than what is recommended below shall not be used.

Check that the fuse operating time is less than 0.4 seconds. Operating time depends on used fuse type and impedance of the supply circuit. Consult the factory about faster fuses. Honeywell offers recommendations also for high speed J (UL & CSA), aR (UL recognized, IEC 60269-4) and gS (IEC 60269-4) fuse ranges.

Frame	Type	$I_L$ [A]	Fuse (gG/gL) [A]	Mains and motor cable Cu [mm <sup>2</sup> ]	Terminal cable size	
					Main terminal	Earth terminal
MR7	230 18P 400 37P	75.0 72.0	80	3*35+16 (Cu) 3*50+16 (Al)	6-70 mm <sup>2</sup> Cu/Al	6-70 mm <sup>2</sup>
	230 22P 400 45P	88.0 87.0	100	3*35+16 (Cu) 3*70+21 (Al)	6-70 mm <sup>2</sup> Cu/Al	6-70 mm <sup>2</sup>
	230 30P 400 55P	105.0 105.0	125	3*50+25 (Cu) 3*70+21 (Al)	6-70 mm <sup>2</sup> Cu/Al	6-70 mm <sup>2</sup>
MR8	230 37P 400 75P	143.0 140.0	160	3*70+35 (Cu) 3*95+29 (Al)	Bolt size M8	Bolt size M8
	230 45P 400 90P	170.0 170.0	200	3*95+50 (Cu) 3*150+41 (Al)	Bolt size M8	Bolt size M8
	230 55P 400 110	208.0 205.0	250	3*120+70 (Cu) 3*185+57 (Al)	Bolt size M8	Bolt size M8
MR9	230 75P 400 132	261.0 261.0	315	3*185+95 (Cu) 2*3*120+41 (Al)	Bolt size M8	Bolt size M8
	230 90P 400 160	310.0 310.0	350	2*3*95+50 (Cu) 2*3*120+41 (Al)	Bolt size M8	Bolt size M8

Table 15. Cable and fuse sizes

The cable dimensioning is based on the criteria of the International Standard IEC60364-5-52: Cables must be PVC-isolated; Max ambient temperature +30°C, max temperature of cable surface +70°C; Use only cables with concentric copper shield; Max number of parallel cables is 9.

When using cables in parallel, **NOTE HOWEVER** that the requirements of both the cross-sectional area and the max number of cables must be observed.

For important information on the requirements of the earthing conductor, see chapter Earthing and earth fault protection of the standard.

For the correction factors for each temperature, see International Standard IEC60364-5-52.

#### 4.1.1.3 Cable and fuse sizes, frames MR4 to MR6, North America

The recommended fuse types are gG/gL (IEC 60269-1) or class T (UL & CSA). The fuse voltage rating should be selected according to the supply network. The final selection should be made according to local regulations, cable installation conditions and cable specification. Bigger fuses than what is recommended below shall not be used.

Check that the fuse operating time is less than 0.4 seconds. Operating time depends on used fuse type and impedance of the supply circuit. Consult the factory about faster fuses. Honeywell offers recommendations also for high speed J (UL & CSA), aR (UL recognized, IEC 60269-4) and gS (IEC 60269-4) fuse ranges.

Frame	Type	$I_L$ [A]	Fuse (class T) [A]	Mains, motor and ground cable, Cu	Terminal cable size	
					Main terminal	Earth terminal
MR4	230 P55 400 1P1	3.7 3.4	6	AWG14	AWG24- AWG10	AWG17- AWG10
	230 P75 400 1P5	4.8	6	AWG14	AWG24- AWG10	AWG17- AWG10
	230 1P1 400 2P2	6.6 5.6	10	AWG14	AWG24- AWG10	AWG17- AWG10
	230 1P5 400 3P0	8.0	10	AWG14	AWG24- AWG10	AWG17- AWG10
	230 2P2 400 4P0	11.0 9.6	15	AWG14	AWG24- AWG10	AWG17- AWG10
	230 3P0 400 5P5	12.5 12.0	20	AWG14	AWG24- AWG10	AWG17- AWG10
MR5	230 4P0 400 7P5	18.0 16.0	25	AWG10	AWG20-AWG5	AWG17-AWG8
	230 5P5 400 11P	24.0 23.0	30	AWG10	AWG20-AWG5	AWG17-AWG8
	230 7P5 400 15P	31.0	40	AWG8	AWG20-AWG5	AWG17-AWG8
MR6	400 18P	38.0	50	AWG4	AWG13-AWG0	AWG13-AWG2
	230 11P 400 22P	48.0 46.0	60	AWG4	AWG13-AWG0	AWG13-AWG2
	230 15P 400 30P*	62.0 61.0	80	AWG4	AWG13-AWG0	AWG13-AWG2

\*. The 460V models require 90-degree wire to meet UL regulations

Table 16. Cable and fuse sizes (MR4 to MR6)

The cable dimensioning is based on the criteria of the Underwriters' Laboratories UL508C: Cables must be PVC-isolated; Max ambient temperature +30°C, max temperature of cable surface +70°C; Use only cables with concentric copper shield; Max number of parallel cables is 9.

When using cables in parallel, **NOTE HOWEVER** that the requirements of both the cross-sectional area and the max number of cables must be observed.

For important information on the requirements of the earthing conductor, see standard Underwriters' Laboratories UL508C. For the correction factors for each temperature, see the instructions of standard Underwriters' Laboratories UL508C.

**4.1.1.4 Cable and fuse sizes, frames MR7 to MR9, North America**

The recommended fuse types are gG/gL (IEC 60269-1) or class T (UL & CSA). The fuse voltage rating should be selected according to the supply network. The final selection should be made according to local regulations, cable installation conditions and cable specification. Bigger fuses than what is recommended below shall not be used.

Check that the fuse operating time is less than 0.4 seconds. Operating time depends on used fuse type and impedance of the supply circuit. Consult the factory about faster fuses. Honeywell offers recommendations also for high speed J (UL & CSA ), aR (UL recognized, IEC 60269-4) and gS (IEC 60269-4) fuse ranges.

Frame	Type	I <sub>L</sub> [A]	Fuse (class T) [A]	Mains, motor and ground cable, Cu	Terminal cable size	
					Main terminal	Earth terminal
MR7	230 18P 400 37P	75.0 72.0	100	AWG2	AWG9-AWG2/0	AWG9-AWG2/0
	230 22P 400 45P	88.0 87.0	110	AWG1	AWG9-AWG2/0	AWG9-AWG2/0
	230 30P 400 55P	105.0	150	AWG1/0	AWG9-AWG2/0	AWG9-AWG2/0
MR8	230 37P 400 75P	143.0 140.0	200	AWG3/0	AWG1-350 kcmil	AWG1-350 kcmil
	230 45P 400 90P	170.0	225	250 kcmil	AWG1-350 kcmil	AWG1-350 kcmil
	230 55P 400 110	208.0 205.0	250	350 kcmil	AWG1-350 kcmil	AWG1-350 kcmil
MR9	230 75P 400 132	261.0	350	2*250 kcmil	AWG1-350 kcmil	AWG1-350 kcmil
	230 90P 400 160	310.0	400	2*350 kcmil	AWG1-350 kcmil	AWG1-350 kcmil

Table 17. Cable and fuse sizes (MR7 to MR9)

The cable dimensioning is based on the criteria of the Underwriters' Laboratories UL508C: Cables must be PVC-isolated; Max ambient temperature +30°C, max temperature of cable surface +70°C; Use only cables with concentric copper shield; Max number of parallel cables is 9.

When using cables in parallel, **NOTE HOWEVER** that the requirements of both the cross-sectional area and the max number of cables must be observed.

For important information on the requirements of the earthing conductor, see standard Underwriters' Laboratories UL508C.

For the correction factors for each temperature, see the instructions of standard Underwriters' Laboratories UL508C.

## 4.2 Cable installation

- Before starting, check that none of the components of the drive is live. Read carefully the warnings in chapter 1.
- Place the motor cables sufficiently far from other cables
- Avoid placing the motor cables in long parallel lines with other cables.
- If the motor cables run in parallel with other cables note the minimum distances between the motor cables and other cables given in table below.

Distance between cables, [m]	Shielded cable, [m]
0.3	≤ 50
1.0	≤ 200

- The given distances also apply between the motor cables and signal cables of other systems.
- The maximum lengths of motor cables (shielded) are 100 m (MR4), 150 m (MR5 and MR6) and 200 m (MR7 to MR9).
- The motor cables should cross other cables at an angle of 90 degrees.
- If cable insulation checks are needed, see chapter Cable and motor insulation checks.

Start the cable installation according to the instructions below:

4.2.1 Frames MR4 to MR7

**1** Strip the motor and mains cables as advised below.

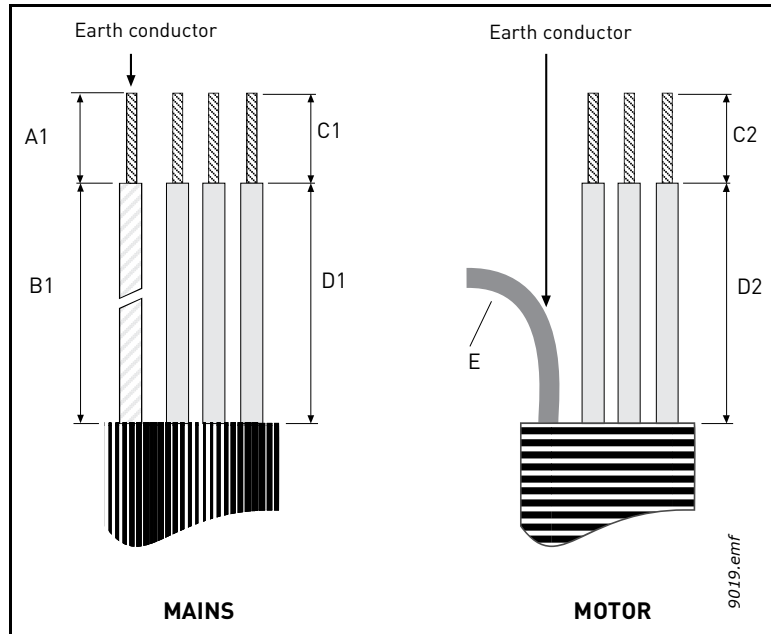

Figure 14. Stripping of cables

Frame	A1	B1	C1	D1	C2	D2	E
MR4	15	35	10	20	7	35	Leave as short as possible
MR5	20	40	10	30	10	40	
MR6	20	90	15	60	15	60	
MR7	20	80	20	80	20	80	

Table 18. Cables stripping lengths [mm]

**2** Open the cover of the drive.

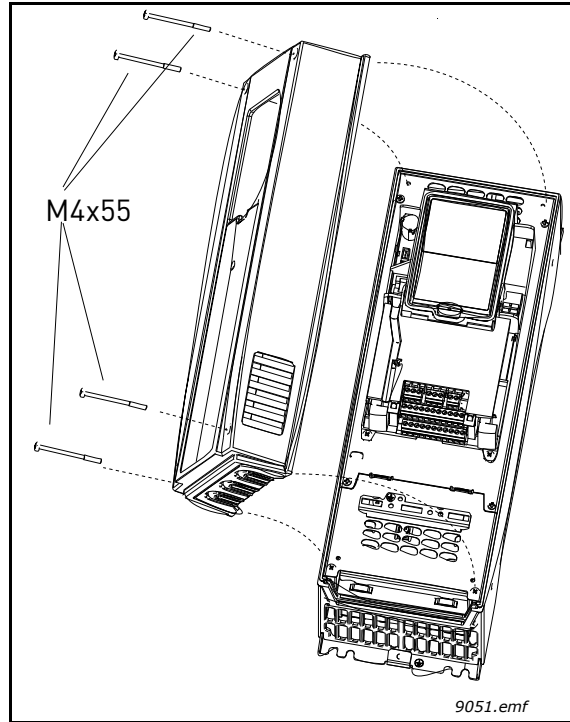

Figure 15.

<b>3</b>	Remove the screws of the cable protection plate. Do not open the cover of the power unit!
----------	---

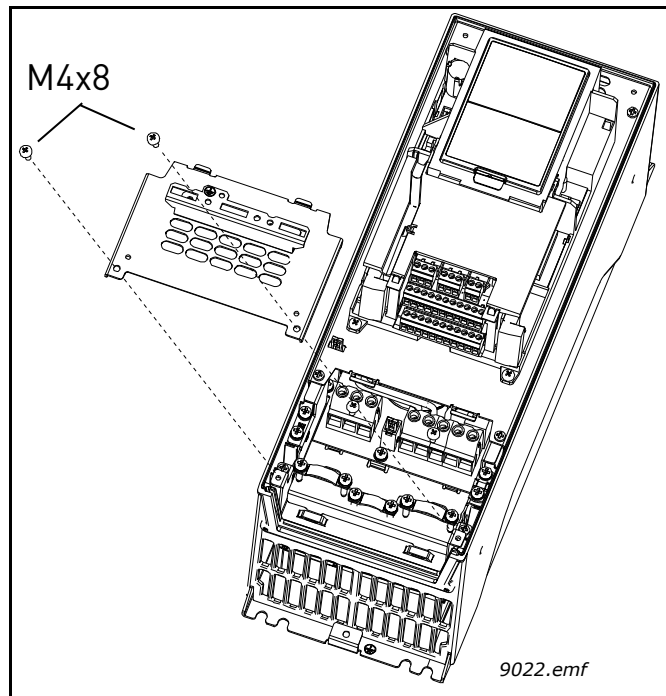

Figure 16.

**4**

Insert the cable grommets (included in the delivery) in the openings of the cable entry plate (included) as shown in the picture (upper pictures EU version, lower pictures US version).

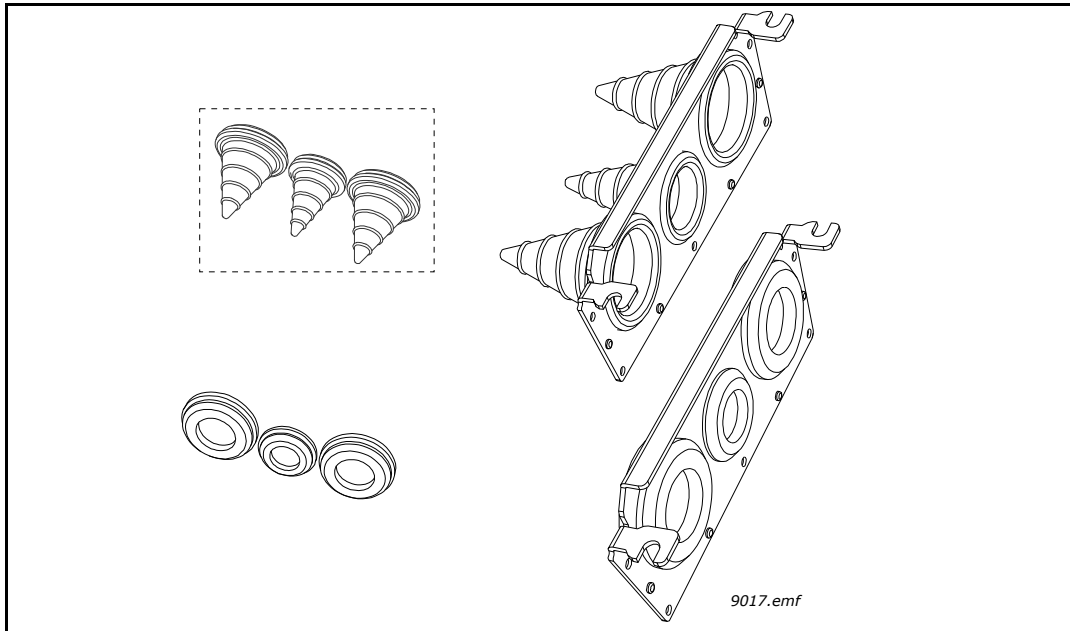

Figure 17.

**5**

- Insert the cables - supply cable, motor cable and optional brake cable - in the openings of the cable entry plate.
- Then cut the rubber grommets open to slide the cables through. Should the grommets fold in while inserting the cable, just draw the cable back a bit to straighten the grommets up.
- Do not cut the grommet openings wider than what is necessary for the cables you are using.

**IMPORTANT NOTE FOR IP54 INSTALLATION:**

To meet the requirements of the enclosure class IP54, the connection between the grommet and the cable must be tight. Therefore, lead the first bit of the cable out of the grommet straight before letting it bend. If this is not possible, the tightness of the connection must be ensured with insulation tape or a cable tie.



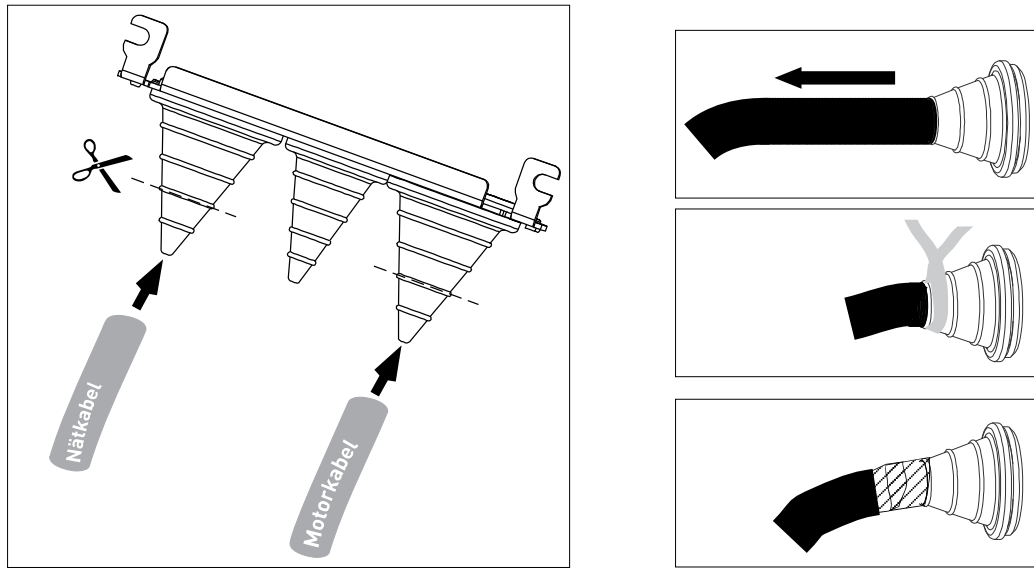

9217.emf

Figure 18.

**6** Detach the cable clamps and the grounding clamps (Figure 19) and place the cable entry plate with the cables in the groove on the drive frame (Figure 20).

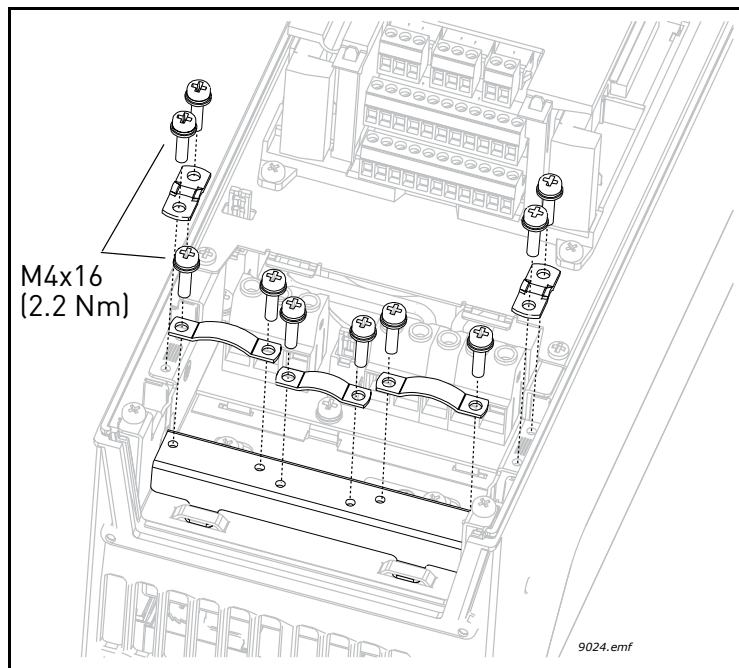

Figure 19.

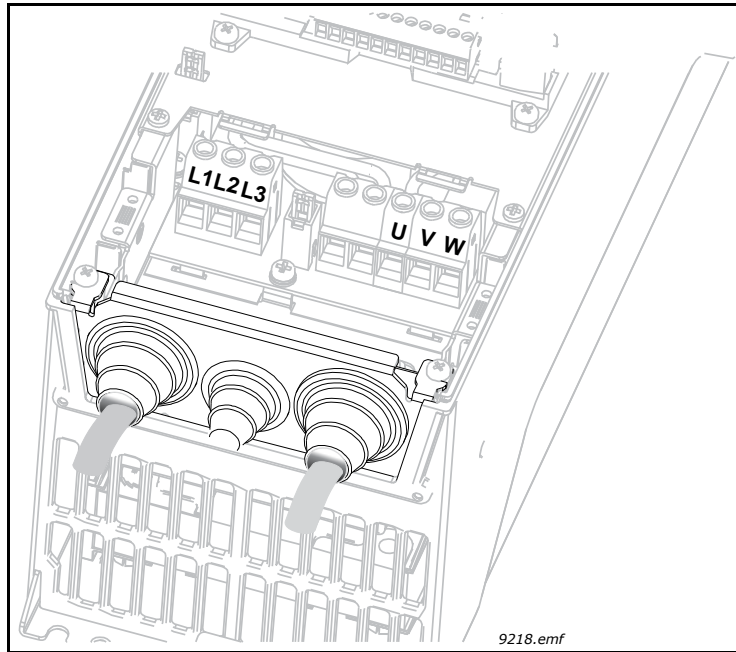

Figure 20.

- |   |   |
|---|---|
| 7 | <p>Connect the stripped cables (see Figure 14 and Figure 18) as shown in Figure 21.</p> <ul style="list-style-type: none"> <li>• Expose the shield of all three cables in order to make a 360-degree connection with the cable clamp (1).</li> <li>• Connect the (phase) conductors of the supply, brake and motor cables into their respective terminals (2).</li> <li>• Form the rest of the cable shield of all three cables into “pigtails” and make a grounding connection with a clamp as shown in Figure 21 (3). Make the pigtails just long enough to reach and be fixed to the terminal - not longer.</li> </ul> |
|---|---|

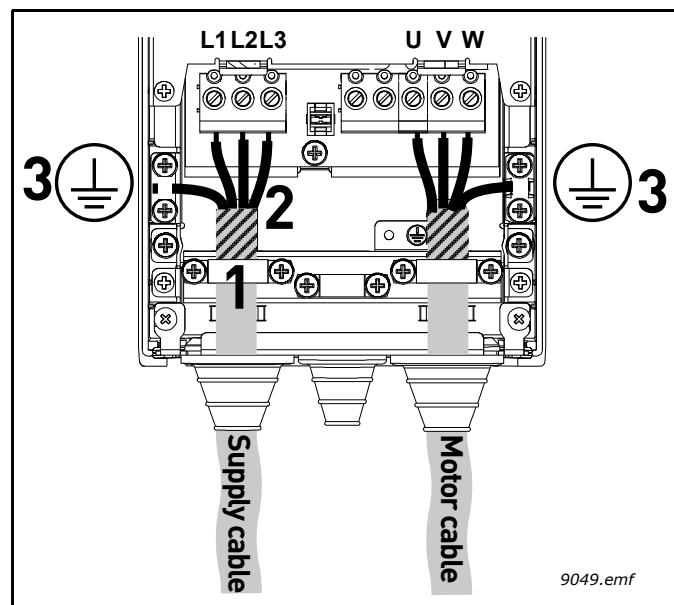



Figure 21.

**Tightening torques of cable terminals:**

Frame	Type	Tightening torque [Nm]/[lb-in.] Power and motor terminals		Tightening torque [Nm]/[lb-in.] EMC grounding clamps		Tightening torque, [Nm]/[lb-in.] Grounding terminals	
		[Nm]	lb-in.	[Nm]	lb-in.	[Nm]	lb-in.
<b>MR4</b>	230 P55—230 3P0 400 1P1—400 5P5	0.5—0.6	4.5—5.3	1.5	13.3	2.0	17.7
<b>MR5</b>	230 4P0—230 7P5 400 7P5—400 15P	1.2—1.5	10.6—13.3	1.5	13.3	2.0	17.7
<b>MR6</b>	230 11P—230 15P 400 18P—400 30P	10	88.5	1.5	13.3	2.0	17.7
<b>MR7</b>	230 18P—230 30P 400 37P—400 55P	8/15*	70.8/132.8*	1.5	13.3	8/15*	70.8/132.8*

\*. Cable clamping (e.g. Ouneva Pressure Terminal Connector)

Table 19. Tightening torques of terminals

<b>8</b>	<p>Check the connection of the earth cable to the motor and the drive terminals marked with .</p> <p><b>NOTE:</b> Two protective conductors are required according to standard EN61800-5-1. See Figure 22 and chapter Earthing and earth fault protection. Use an M5 size screw and tighten it to 2.0 Nm (17.7 lb-in.).</p>
----------	--

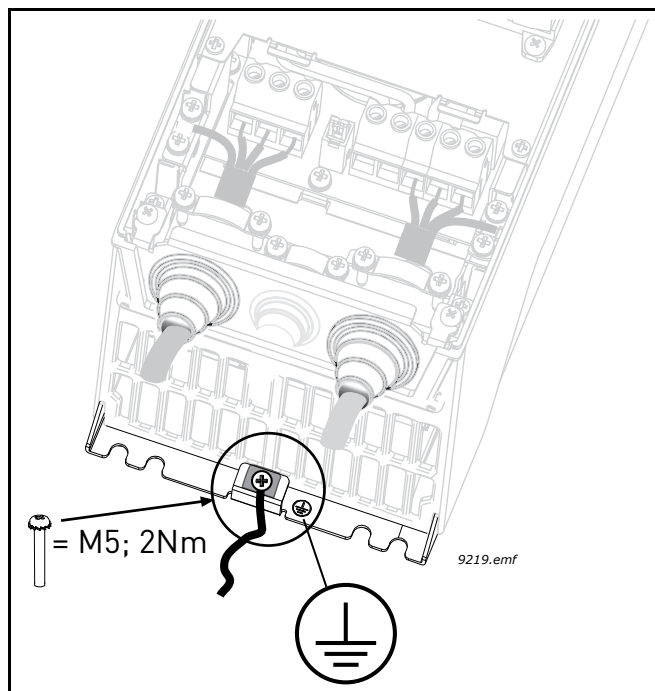

Figure 22. Additional protective earthing connector

**9** Re-mount the cable protection plate (Figure 23) and the cover of the drive.

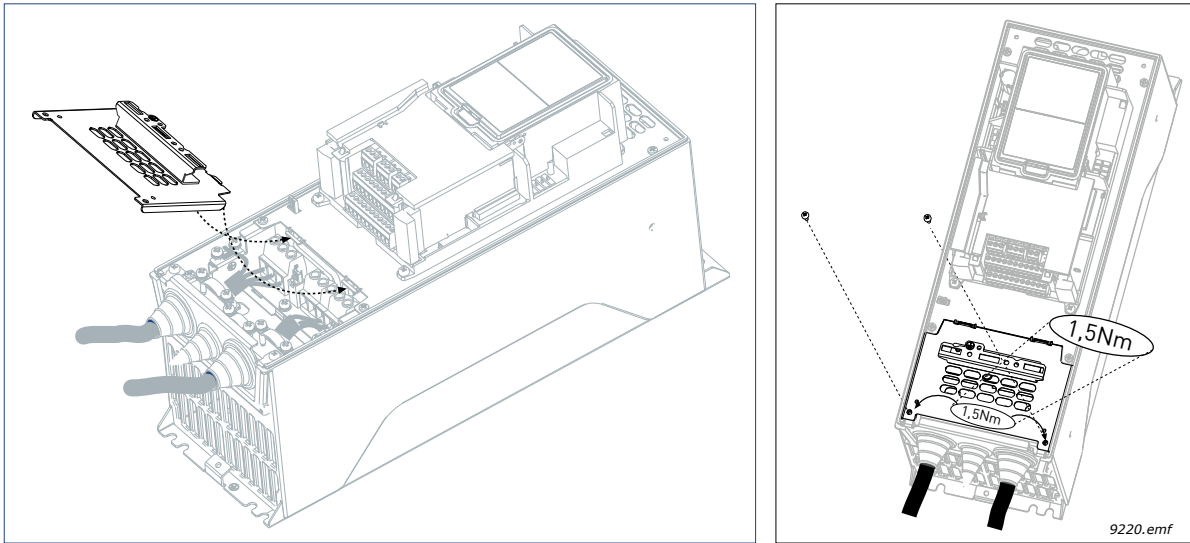

Figure 23. Re-mounting of cover components

#### 4.2.2 Frames MR8 and MR9

**1** Strip the motor and mains cables as advised below.

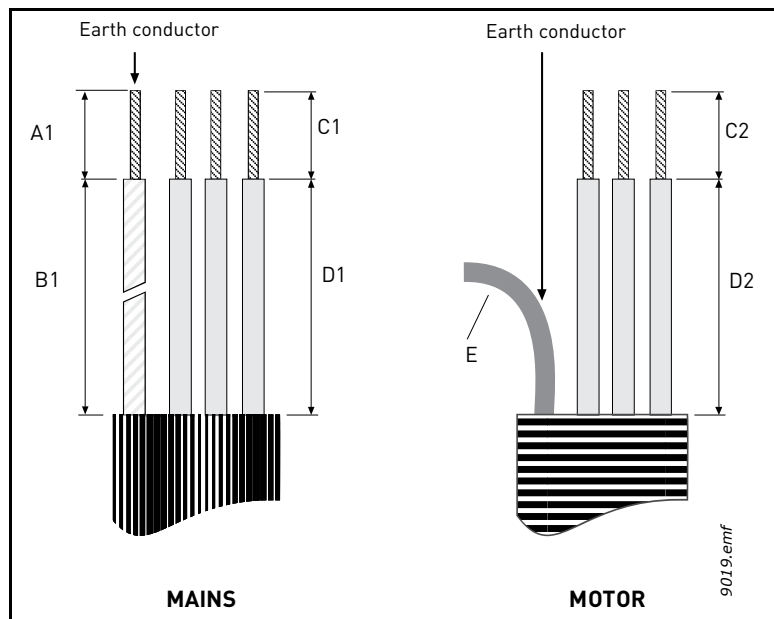

Figure 24. Stripping of cables

Frame	A1	B1	C1	D1	C2	D2	E
MR8	40	180	25	300	25	300	Leave as short as possible
MR9	40	180	25	300	25	300	

Table 20. Cables stripping lengths [mm]

**2** MR9 only: Remove the main cover of the drive.

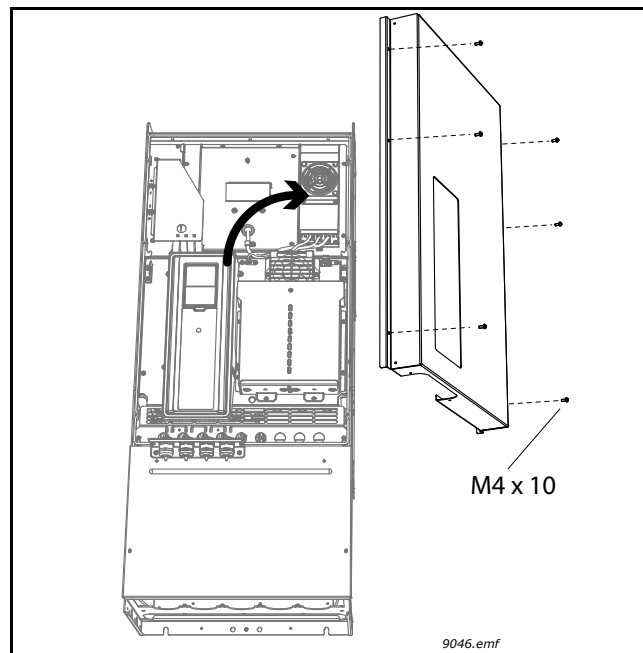

Figure 25.

**3** Remove the cable cover (1) and the cable fitting plate (2).

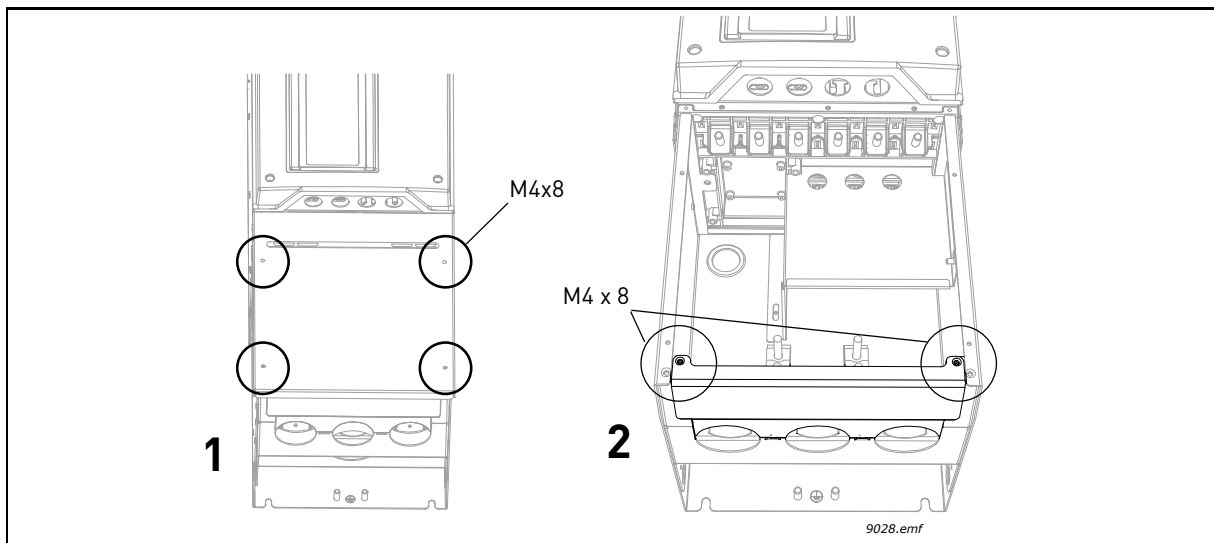

Figure 26. Removing cable cover and cable fitting plate (MR8).

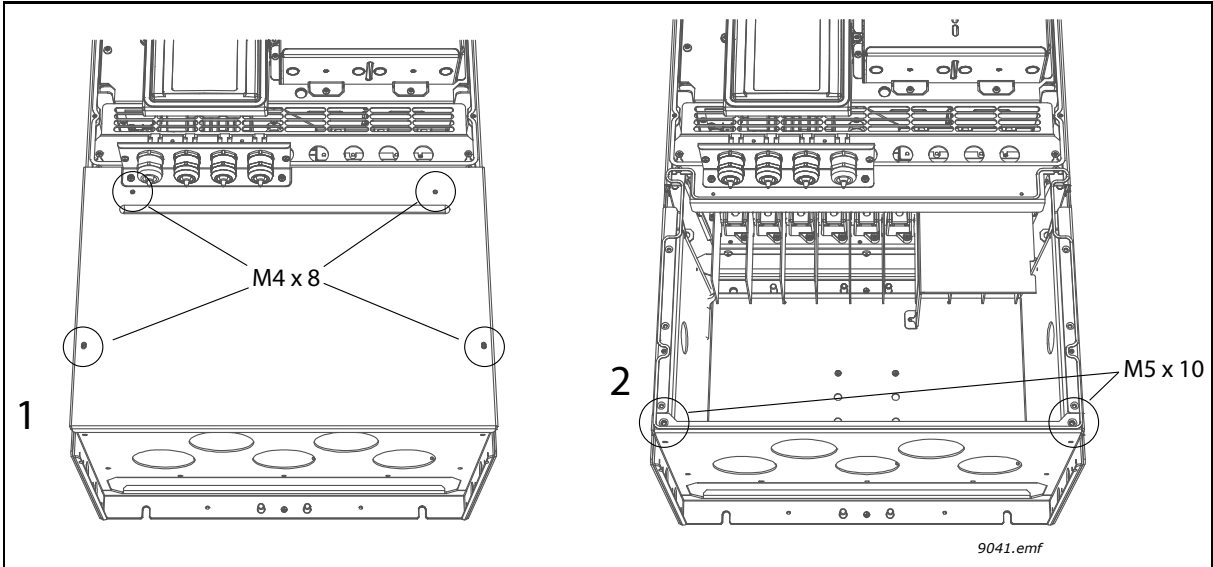

Figure 27. Removing cable cover and cable fitting plate (MR9).

**4** MR9 only: Loosen the screws and remove the sealing plate.

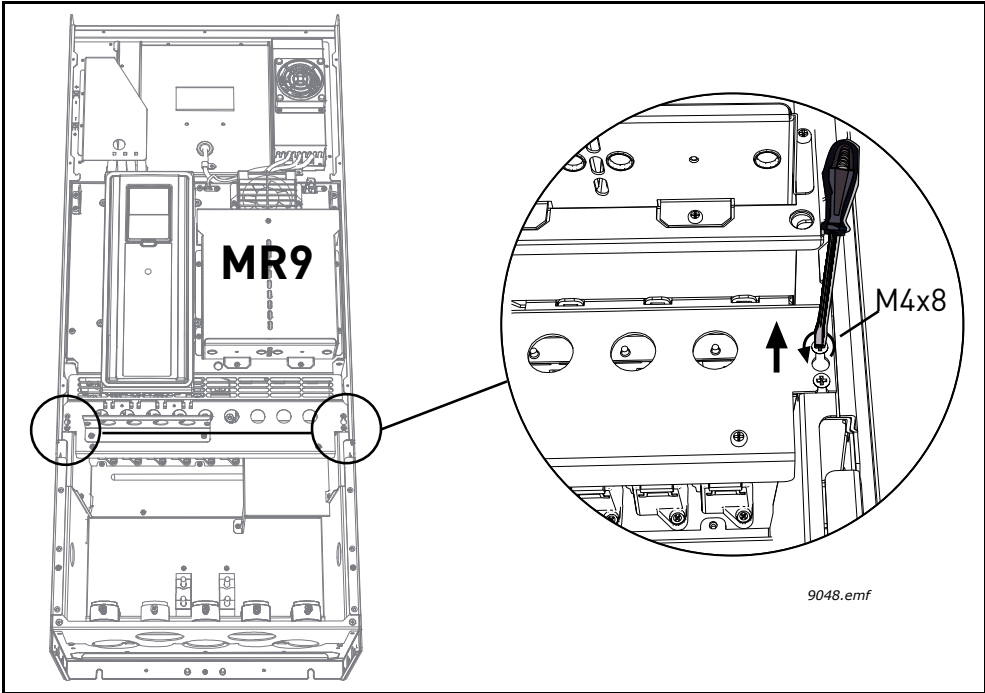

Figure 28.

**5** Remove the EMC shield plate.

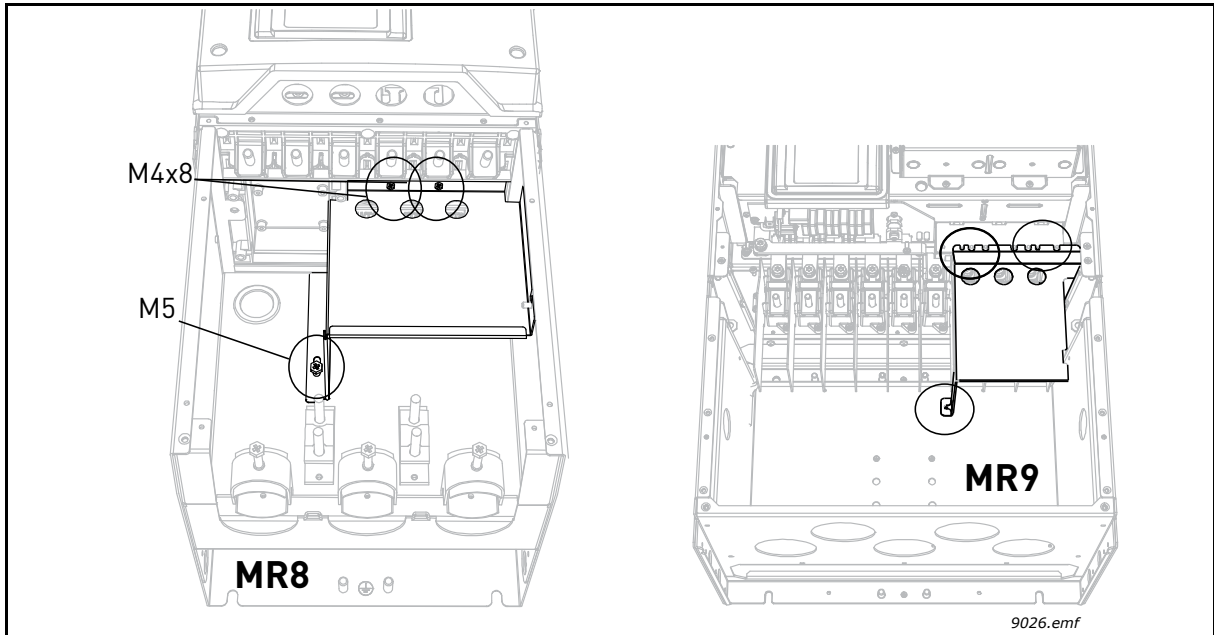

Figure 29.

**6** Locate the terminals. **OBSERVE** the exceptional placement of motor cable terminals in MR8!

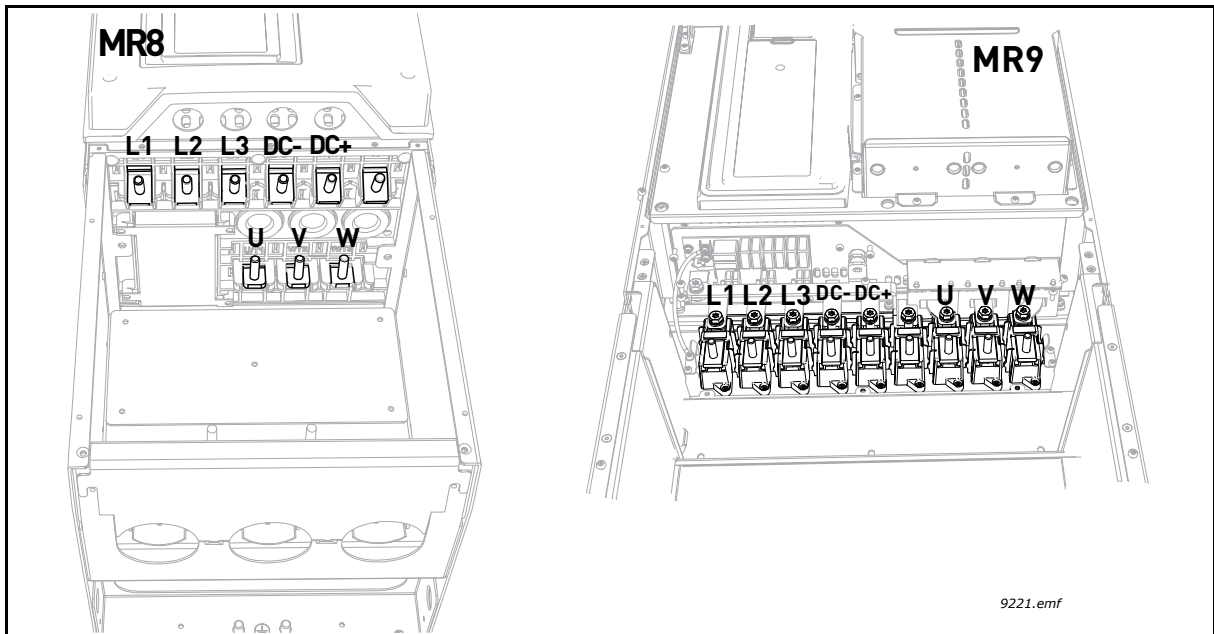

Figure 30.

**7**

Cut the rubber grommets open to slide the cables through. Should the grommets fold in while inserting the cable, just draw the cable back a bit to straighten the grommets up. Do not cut the grommet openings wider than what is necessary for the cables you are using.

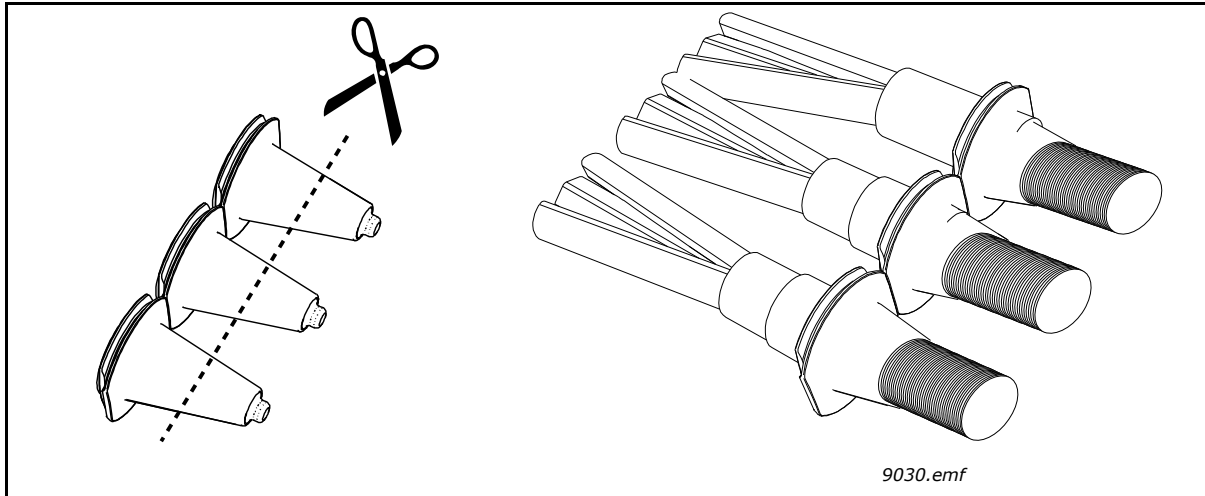

Figure 31.

**8**

Place the grommet with the cable so that the frame end plate fits in the groove on the grommet, see Figure 32.

To meet the requirements of the enclosure class IP54, the connection between the grommet and the cable must be tight. Therefore, lead the first bit of the cable out of the grommet straight before letting it bend. If this is not possible, the tightness of the connection must be ensured with insulation tape or a cable tie. As an example, see Figure 18.

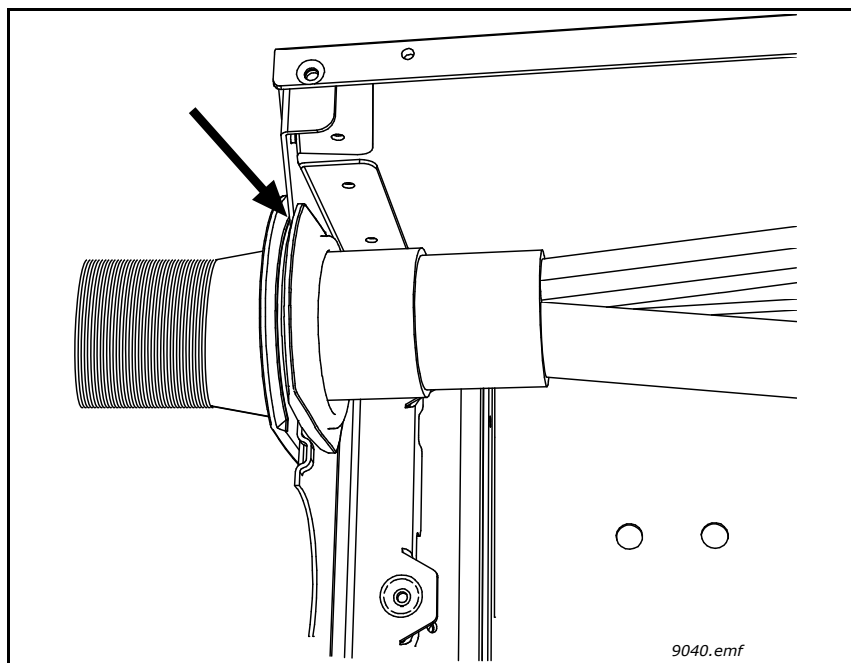

Figure 32.



**9**

If you use thick cables insert the cable insulators in between the terminals in order to avoid contact between the cables.

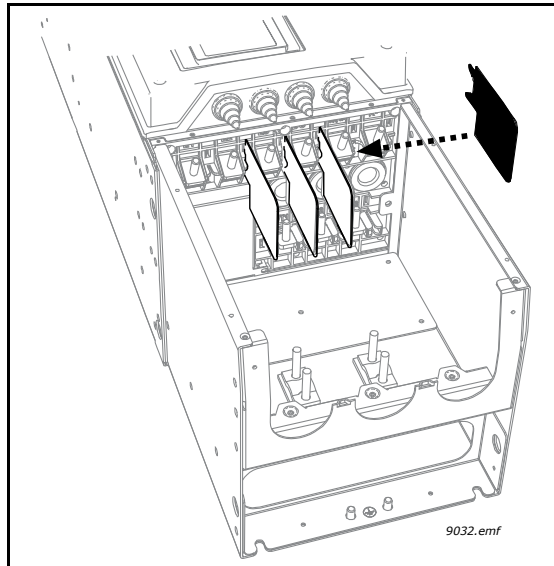

Figure 33.

**10**

Connect the cables stripped as shown in Figure 24.

- Connect the (phase) conductors of the supply, brake and motor cables into their respective terminals (a).
- Form the rest of the cable shield of all cables into “pigtails” and make a grounding connection as shown in Figure 34 (b) using the clamp from the *Accessories bag*.
- **NOTE:** If you use several cables on one connector observe the position of cable lugs on top of each other. See Figure 35 below.

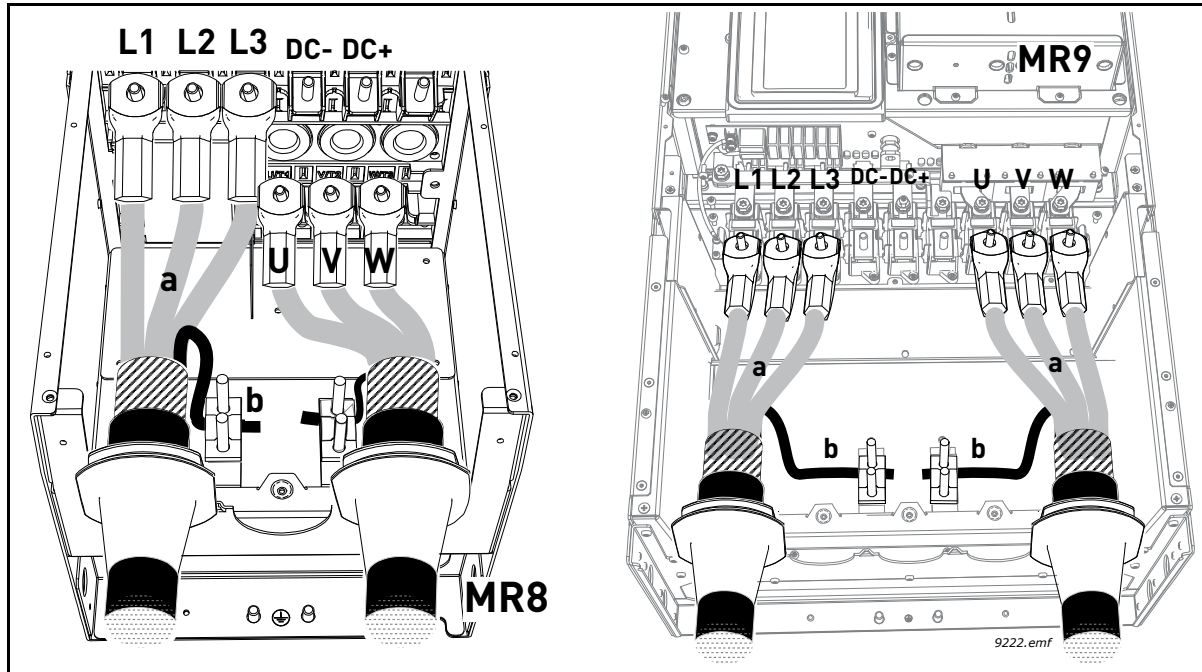

Figure 34.

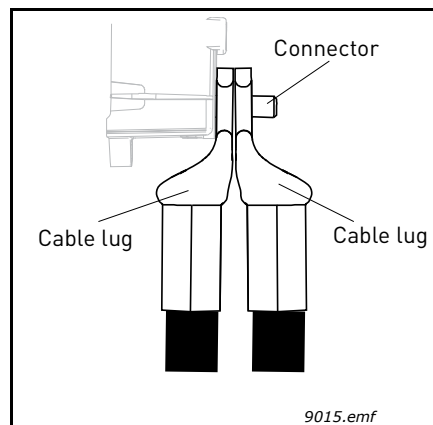

Figure 35. Placing two cable lugs on top of each other

**Tightening torques of cable terminals:**

Frame	Type	Tightening torque [Nm]/[lb-in.] Power and motor terminals		Tightening torque [Nm]/[lb-in.] EMC grounding clamps		Tightening torque, [Nm]/[lb-in.] Grounding terminals	
		[Nm]	lb-in.	[Nm]	lb-in.	[Nm]	lb-in.
MR8	230 37P—230 55P	20/40*	177/354*	1.5	13.3	20	177
	400 75P—400 110						
MR9	230 75P—230 90P	20/40*	177/354*	1.5	13.3	20	177
	400 132—400 160						

\*. Cable clamping (e.g. Ouneva Pressure Terminal Connector)

Table 21. Tightening torques of terminals

**11**

Expose the shield of all three cables in order to make a 360-degree connection with the cable clamp.

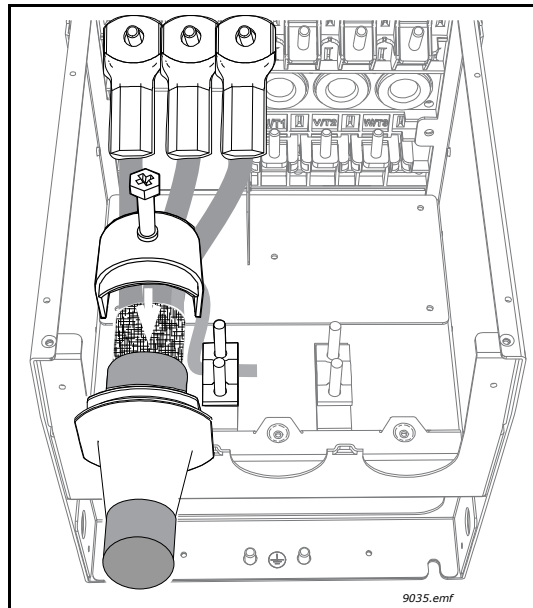

Figure 36.

**12**

Remount now first the EMC shield plate (see Figure 30) and then the sealing plate for MR9 (see Figure 29).

**13**

Re-attach then the cable fitting plate and then the cable cover.

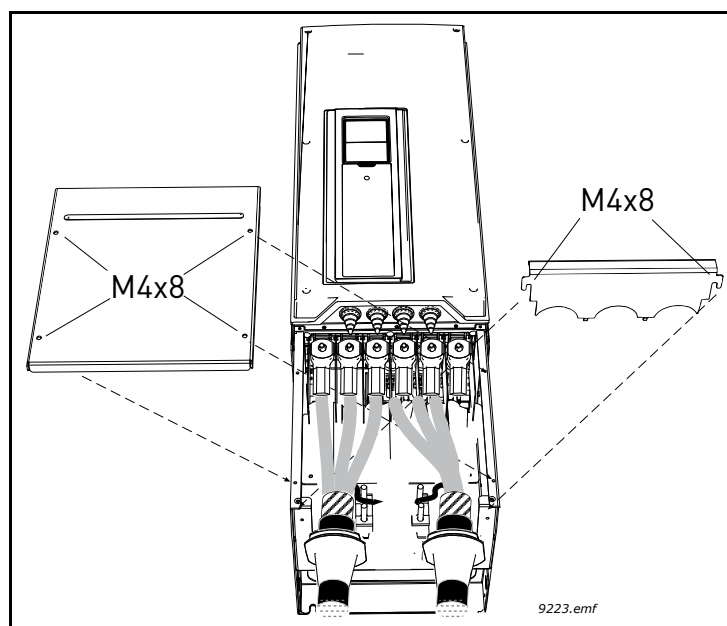

Figure 37.

**14**

**MR9 only:** Now re-mount the main cover (unless you want to make the control connections first).

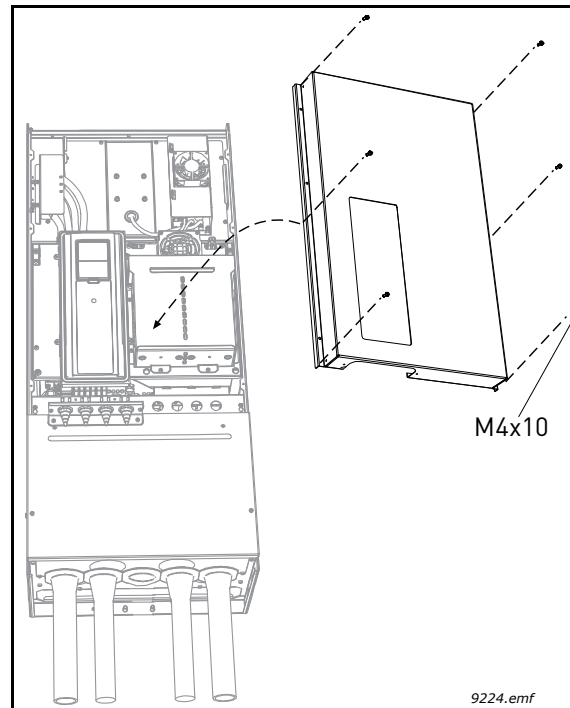



Figure 38.

**15**

Check the connection of the earth cable to the motor and the drive terminals marked with .

**NOTE:** Two protective conductors are required according to standard EN61800-5-1. See chapter Earthing and earth fault protection. Connect the protective conductor using a cable shoe and an M8 screw (included in the *Accessories bag*) on either of the screw connectors as advised in Figure 39.

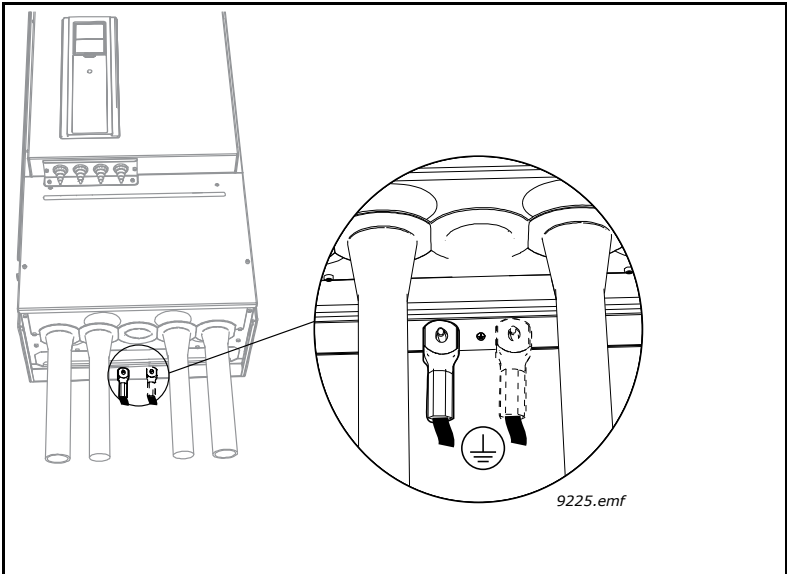

Figure 39.

### **4.3 Installation in corner-grounded network**

Corner grounding is allowed for the drive types rating from 72 A to 310 A at 380...480 V supply and from 75 A to 310 A at 208...240 V supply.

In these circumstances the EMC protection class must be changed to level C4 following the instructions in chapter 6.3 of this manual.

Corner grounding is not allowed for the drive types with rating from 3.4 A to 61 A at 380...480 V supply and 3.7 A to 62 A with 208...240 V supply.

## 5. CONTROL UNIT

The control unit of the drive consists of the control board and additional boards (option boards) connected to the slot connectors of the control board.

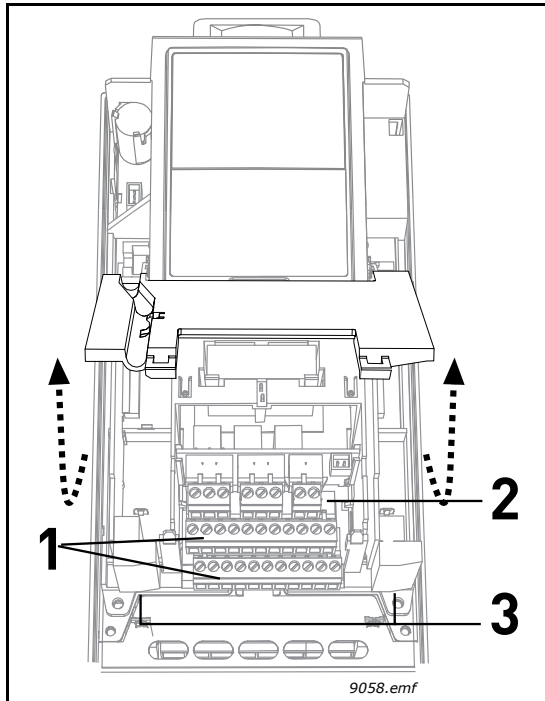

Locations of essential control unit components:

- 1 = Control terminals of the control board
- 2 = Terminals of relay board
- 3 = Optional boards
- 4 = Jumper for digital inputs, see chapter 5.1.2.2

Figure 40. Location of control unit components

When delivered from the factory, the control unit of the drive contains the standard controlling interface - the control terminals of the control board and the relay board. On the next pages you will find the arrangement of the control I/O and the relay terminals, the general wiring diagram and the control signal descriptions.

The control board can be powered externally (+24VDC, 1000mA,  $\pm 10\%$ ) by connecting the external power source to terminal #30, see page 46. This voltage is sufficient for parameter setting and for keeping the control unit active. Note however that the measurements of the main circuit (e.g. DC-link voltage, unit temperature) are not available when the mains is not connected.

### 5.1 Control unit cabling

The basic control unit connections are presented in Figure 41 below. The control board is equipped with 30 fixed control I/O terminals. All signal descriptions are given in Tables 23 to 24.

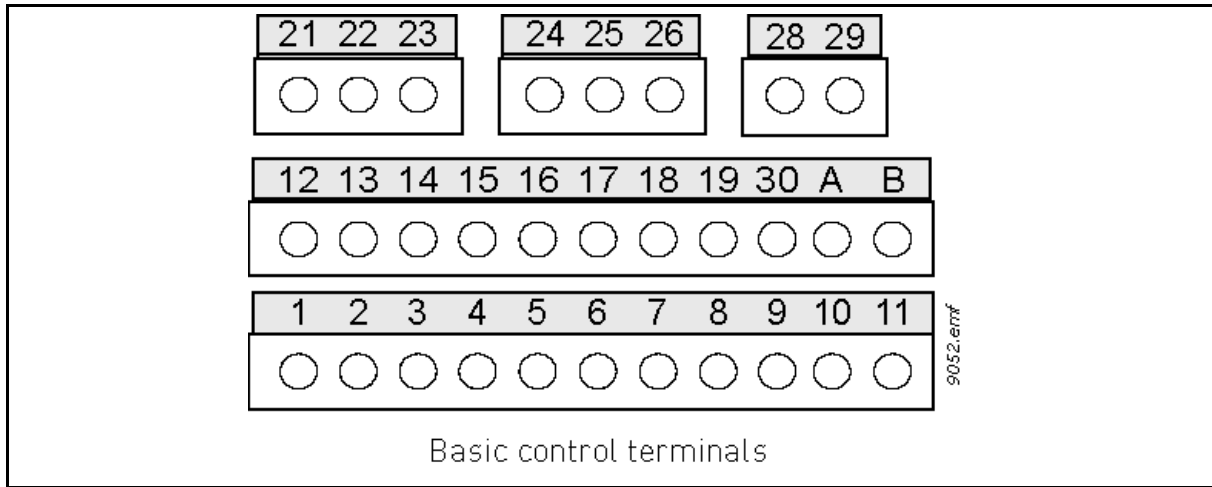

Figure 41.

#### 5.1.1 Control cable sizing

The control cables shall be at least 0.5 mm<sup>2</sup> screened multicore cables, see Table 13. The maximum terminal wire size is 2.5 mm<sup>2</sup> for the relay and other terminals.

Find the tightening torques of the control and relay board terminals in Table 22 below.

Terminal screw	Tightening torque	
	Nm	lb-in.
All I/O and relay terminals (screw M3)	0.5	4.5

Table 22. Control cable tightening torques



### 5.1.2 Control terminals and DIP switches

The terminals of the *Standard I/O board* and the *Relay board* are described below. For more information on the connections, see chapter 7.2.1.

The terminals shown on shadowed background are assigned for signals with optional functions selectable with DIP switches. See more information in chapter 5.1.2.1 on page 47.

Standard I/O board			
Terminal	Signal	Default	
1	+10 Vref	Reference output	
2	AI1+	Analogue input, voltage or current	Voltage
3	AI1-	Analogue input common (current)	
4	AI2+	Analogue input, voltage or current	Current
5	AI2-	Analogue input common (current)	
6	24Vout	24V aux. voltage	
7	GND	I/O ground	
8	DI1	Digital input 1	Start FWD
9	DI2	Digital input 2	Start REV
10	DI3	Digital input 3	Fault
11	CM	Common A for DIN1-DIN6*	
12	24Vout	24V aux. voltage	
13	GND	I/O ground	
14	DI4	Digital input 4	Preset freq select 1
15	DI5	Digital input 5	Preset freq select 2
16	DI6	Digital input 6	Fault reset
17	CM	Common A for DIN1-DIN6*	
18	A01+	Analogue signal (+output)	Output frequency
19	A0-/GND	Analogue output common	
30	+24 Vin	24V auxiliary input voltage (input UPS voltage)	
A	RS485	Serial bus, negative	
B	RS485	Serial bus, positive	

\*Digital inputs can be isolated from ground, see chapter 5.1.2.2.

11442\_uk

Table 23. Control I/O terminal signals on standard I/O board and connection example

From Standard I/O board		Relay board 2			Default	
From term. #12	From term. #13	Terminal	Signal	Signal		
		21	R01/1 NC		Relay output 1	RUN
		22	R01/2 CM			
		23	R01/3 NO			
		24	R02/1 NC		Relay output 2	FAULT
		25	R02/2 CM			
		26	R02/3 NO			
		28	TI1+		Thermistor input	No action
		29	TI1-			

11443\_uk

Table 24. Control I/O terminal signals on relay board and connection example

5.1.2.1 Selection of terminal functions with dip switches

The shadowed terminals in Table 23 allow for three functional selections each with the so-called *dip switches*. The switches have three positions, left, middle and right. The middle position is for *Test mode*. See figure to locate the switches and make appropriate selections for your requirements.

The DGND switch is for isolating digital inputs from ground. The digital inputs (terminals 8-10 and 14-16) on the standard I/O board can also be isolated from ground by setting the dip switch on the control board to position OFF.

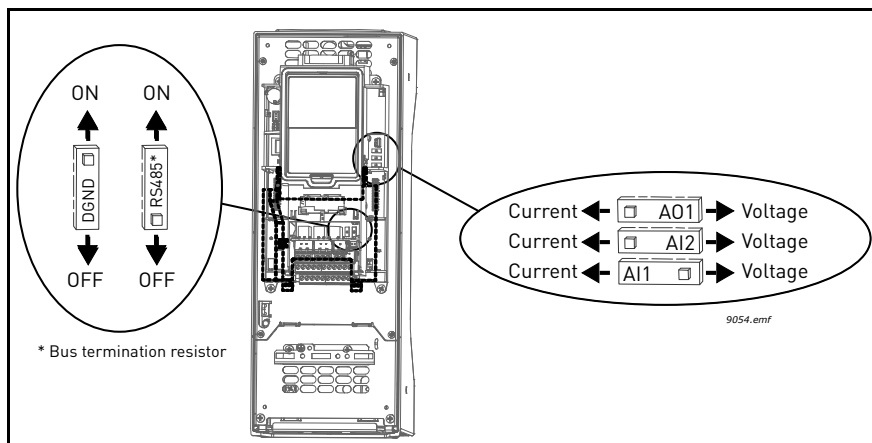
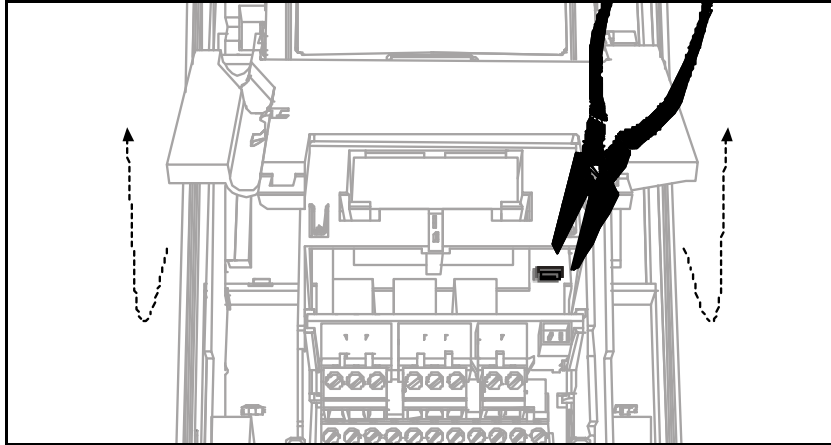

Figure 42. Dip switches

### 5.1.2.2 Isolating digital inputs from ground

The digital inputs (terminals 8-10 and 14-16) on the standard I/O board can be isolated from ground by removing a jumper on the control board. See Figure 43. Lift the plastic lid to expose the jumper and apply long-nose pliers or similar to remove it.



*Figure 43. Remove this jumper to isolate the digital inputs from ground.*

## 5.2 I/O cabling and fieldbus connection

The drive can be connected to fieldbus either through RS485 or Ethernet. The connection for RS485 is on the standard I/O board (terminals A and B) and the connection for Ethernet is under the drive cover, left to the control keypad. See Figure 44.

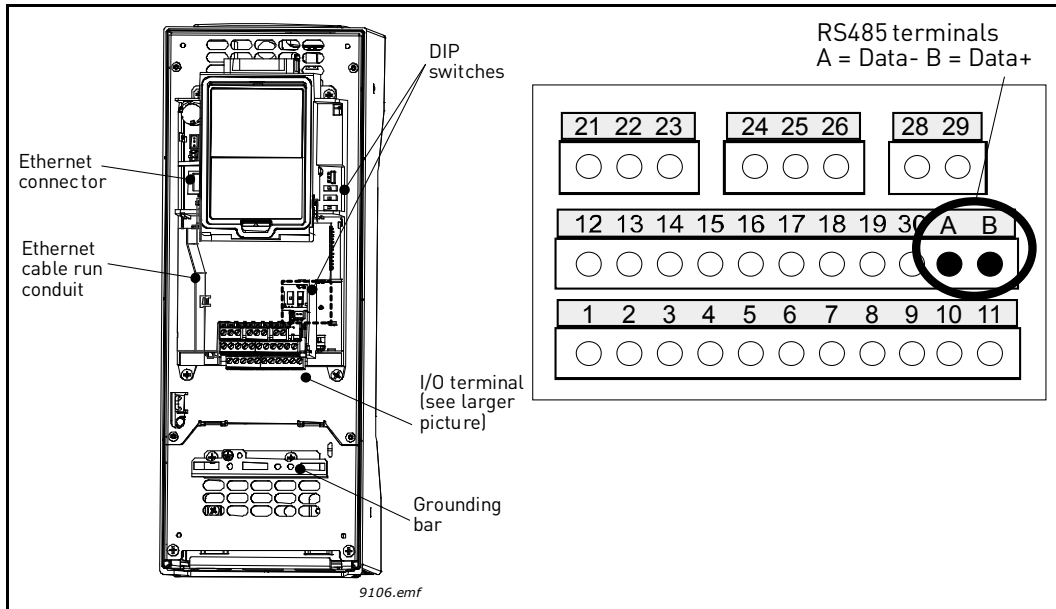

Figure 44.

### 5.2.1 Prepare for use through Ethernet

#### 5.2.1.1 Ethernet cable data

Connector	Shielded RJ45 connector; <b>NOTE:</b> Max length of the connector 40mm.
Cable type	CAT5e STP
Cable length	Max .100m

Table 25. Ethernet cable data

<b>1</b>	<p>Connect the Ethernet cable (see specification on page 49) to its terminal and run the cable through the conduit as shown in Figure 45.</p> <p><b>NOTE:</b> Pay attention that the length of the connector does not exceed 40 mm. See Figure 50.</p>
----------	--

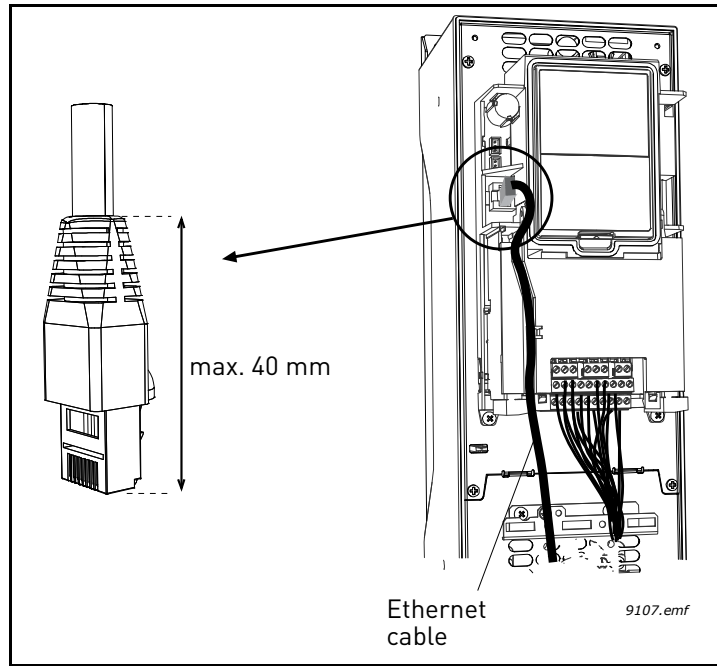

Figure 45.

2	<p><b>Protection class IP21:</b> Cut free the opening on the drive cover for the Ethernet cable.</p> <p><b>Protection class IP54:</b> Cut the rubber grommets open to slide the cables through. Should the grommets fold in while inserting the cable, just draw the cable back a bit to straighten the grommets up. Do not cut the grommet openings wider than what is necessary for the cables you are using.</p> <p><b>IMPORTANT:</b> To meet the requirements of the enclosure class IP54, the connection between the grommet and the cable must be tight. Therefore, lead the first bit of the cable out of the grommet <b>straight</b> before letting it bend. If this is not possible, the tightness of the connection must be ensured with insulation tape or a cable tie.</p>
---	--

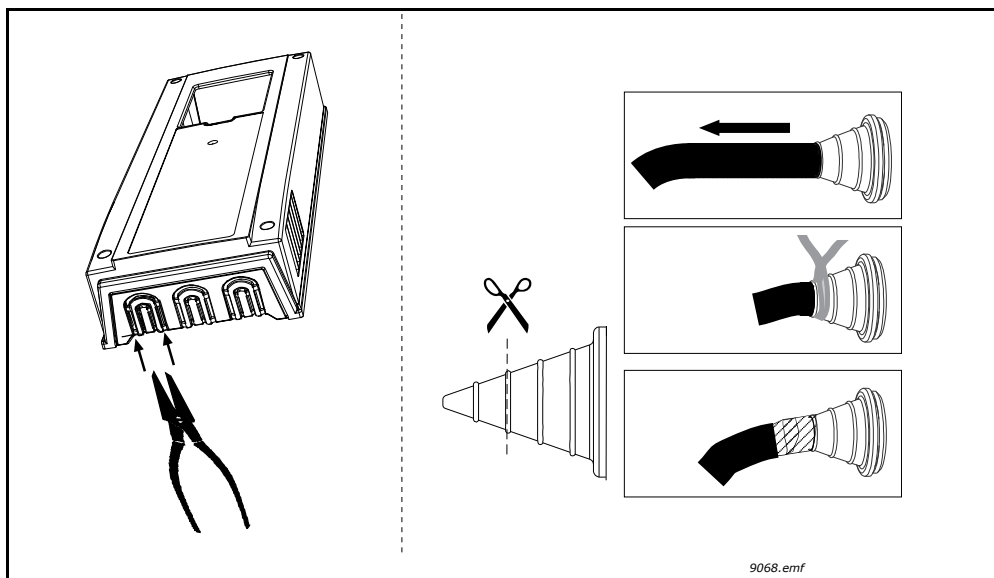

Figure 46. Left: IP21, Right: IP54

**3** Remount the drive cover. **NOTE:** When planning the cable runs, remember to keep the distance between the Ethernet cable and the motor cable at a minimum of 30 cm.

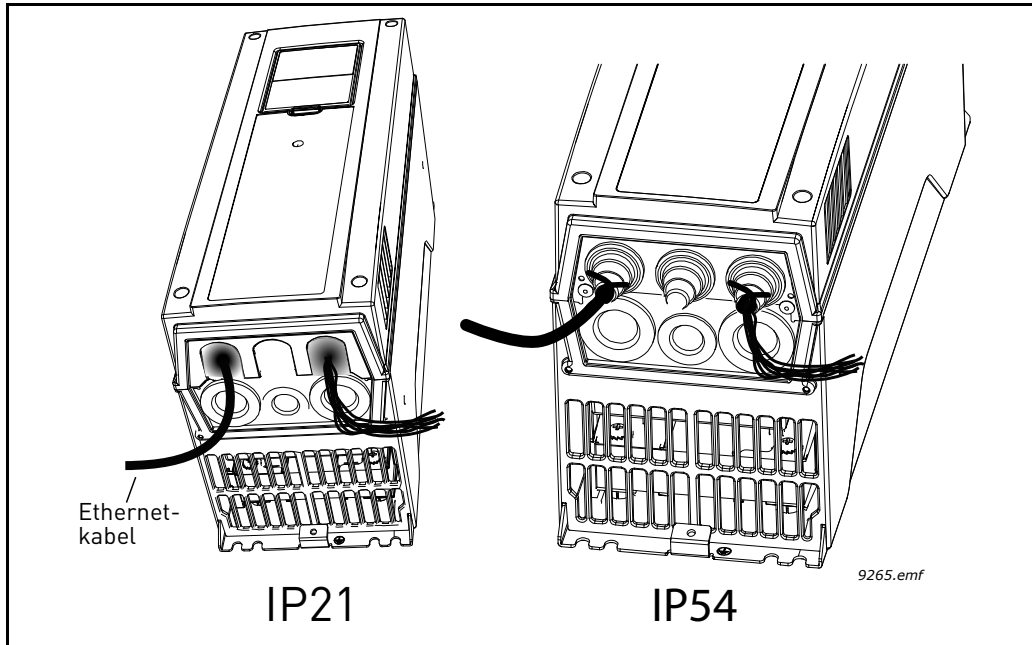

Figure 47.

For more detailed information, see the user's manual of the fieldbus you are using.

**5.2.2 Prepare for use through MS/TP**

5.2.2.1 RS485 cable data

Connector	2.5 mm <sup>2</sup>
Cable type	STP (Shielded Twisted Pair), type Belden 9841 or similar
Cable length	Depends on the used fieldbus. See respective bus manual.

Table 26. RS485 cable data

Strip about 15 mm of the RS485 cable (see specification on page 55) and cut off the grey cable shield. Remember to do this for both bus cables. Leave no more than 10 mm of the cable outside the terminal block and strip the cables at about 5 mm to fit in the terminals. See picture below.

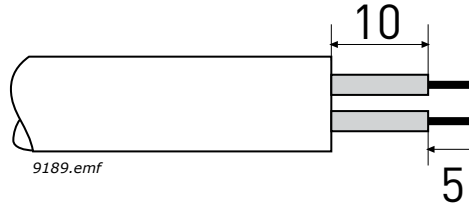

**1**

Also strip the cable now at such a distance from the terminal that you can fix it to the frame with the grounding clamp. Strip the cable at a maximum length of 15 mm. Do not strip the aluminum cable shield!

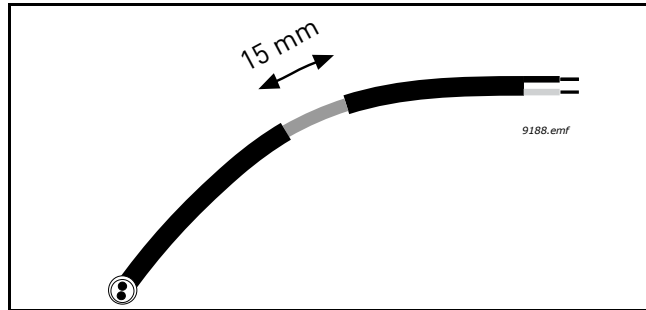

**2**

Then connect the cable to its appropriate terminals on the drive standard terminal block, terminals A and B (A = negative, B = positive). See Figure 48.

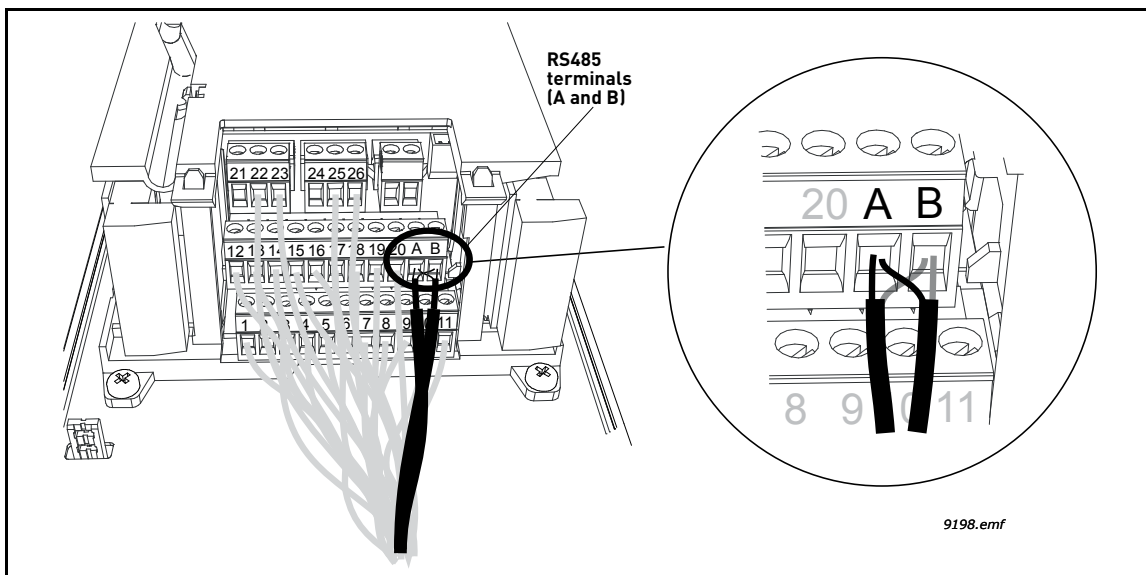
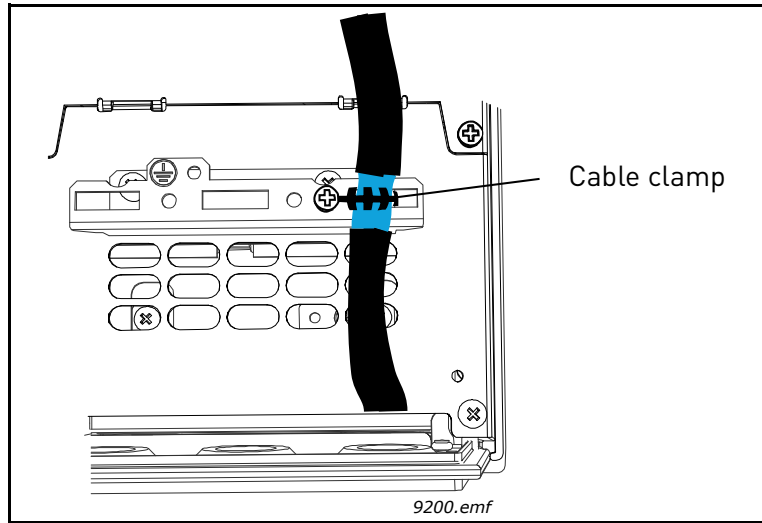

Figure 48.

3

Using the cable clamp included in the delivery of the drive, ground the shield of the RS485 cable to the frame of the drive.



4

If the drive is the last device on the bus, the bus termination must be set. Locate the DIP switches to the right of the control keypad of the drive and turn the switch for the RS485 bus termination resistor to position ON. Biasing is built in the termination resistor. See also step 7 on page 54.

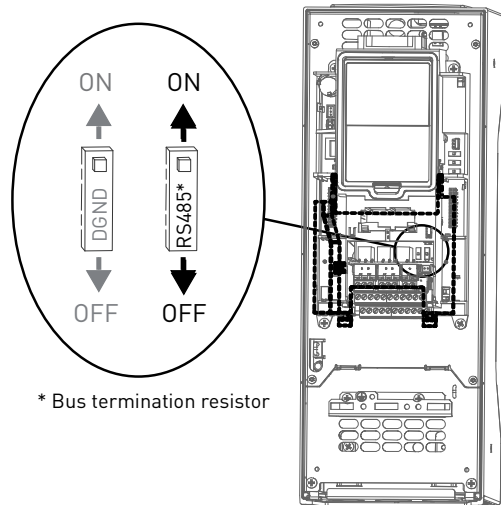

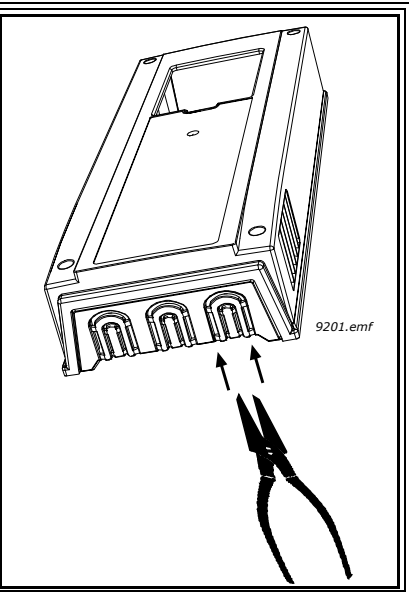
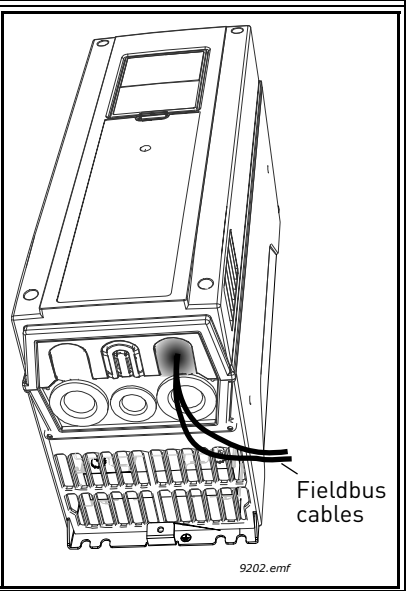
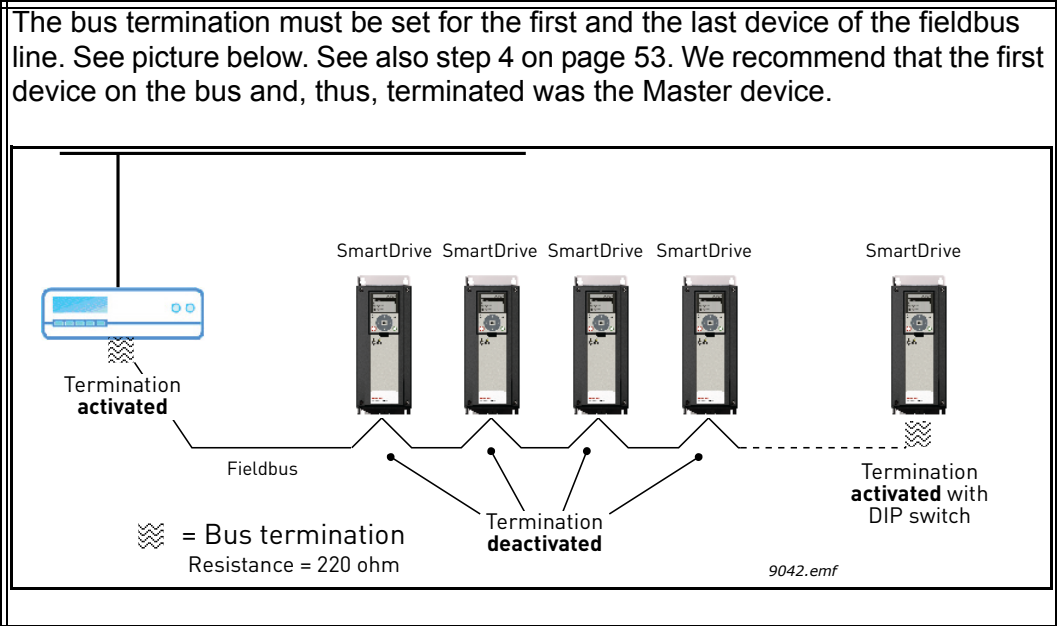

<p style="text-align: center; font-size: 2em; font-weight: bold;">5</p>	<p>Unless already done for the other control cables, cut free the opening on the drive cover for the RS485 cable (protection class IP21).</p>	
<p style="text-align: center; font-size: 2em; font-weight: bold;">6</p>	<p>Remount the drive cover and run the RS485 cables as shown in picture.  <b>NOTE:</b> When planning the cable runs, remember to keep the distance between the fieldbus cable and the motor cable at a minimum of 30 cm.</p>	
<p style="text-align: center; font-size: 2em; font-weight: bold;">7</p>	<p>The bus termination must be set for the first and the last device of the fieldbus line. See picture below. See also step 4 on page 53. We recommend that the first device on the bus and, thus, terminated was the Master device.</p> 	

**5.2.3 RS485 cable data**

Connector	2.5 mm <sup>2</sup>
Cable type	STP (Shielded Twisted Pair), type Belden 9841 or similar
Cable length	Depends on the used fieldbus. See respective bus manual.

*Table 27. RS485 cable data*

### 5.3 Changing the battery for Real Time Clock (RTC)

Enabling the functions of the *Real Time Clock (RTC)* requires that a battery is installed in the drive.

The place for the battery can be found in all frames left to the control keypad (see Figure 49).

Detailed information on the functions of the *Real Time Clock (RTC)* can be found in the HVAC Application Manual.

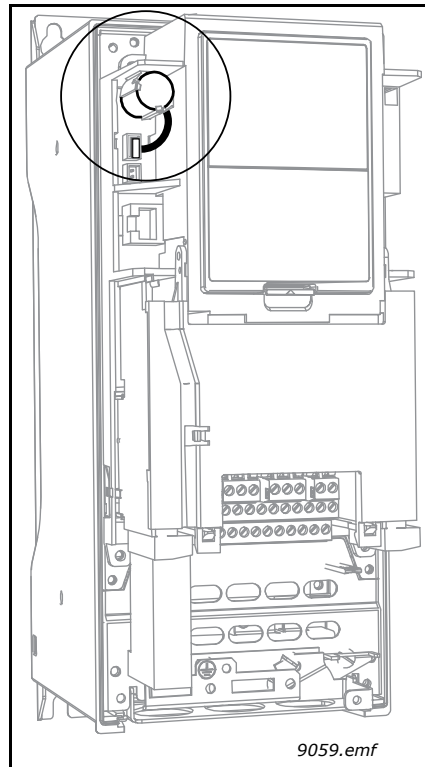

Figure 49. Optional battery

### 5.4 Galvanic isolation barriers

The control connections are isolated from the mains potential and the GND terminals are permanently connected to ground. See Figure 50.

The digital inputs are galvanically isolated from the I/O ground. The relay outputs are additionally double-isolated from each other at 300VAC (EN-50178).

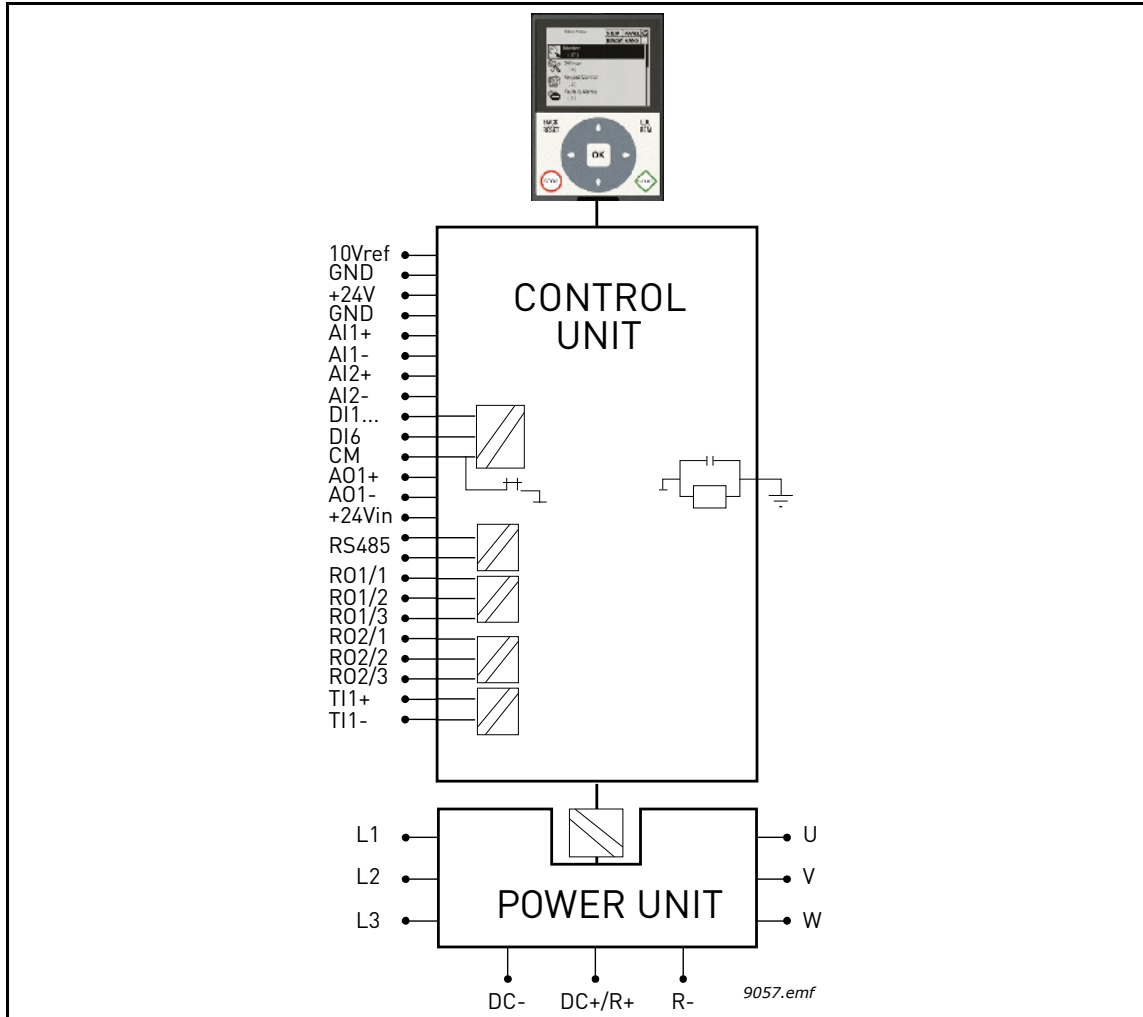

Figure 50. Galvanic isolation barriers

## 6. COMMISSIONING

*Before commissioning, note the following directions and warnings:*



Internal components and circuit boards of the drive (except for the galvanically isolated I/O terminals) are live when it is connected to mains potential. Coming into contact with this voltage is extremely dangerous and may cause death or severe injury.



The motor terminals U, V, W and the brake resistor terminals (R+/R- (MR4-MR6) or DC+/R+ and R- (MR7 and bigger)) are live when the drive is connected to mains, even if the motor is not running.



The control I/O-terminals are isolated from the mains potential. However, the relay outputs and other I/O-terminals may have a dangerous control voltage present even when the drive is disconnected from mains.



Do not make any connections to or from the frequency converter when it is connected to the mains.



After disconnecting the frequency converter from the mains, wait until the fan stops and the indicators on the keypad go out (if no keypad is attached see the indicators on the cover). Wait 5 more minutes before doing any work on the connections of the drive. Do not open the cover before this time has expired. After expiration of this time, use a measuring equipment to absolutely ensure that no voltage is present. Always ensure absence of voltage before electrical work!



Before connecting the drive to mains make sure that the front and cable covers of the drive are closed.



Corner grounding is allowed for the drive types with ratings from 72 A to 310 A at 380...480 V supply and from 75 A to 310 A at 208...240 V supply. Remember to change the EMC level by removing the jumpers. See chapter 6.3.

## 6.1 Commissioning of the drive

Read carefully the safety instructions in Chapter 1 and above and follow them.

After the installation:

- Check that both the drive and the motor are **grounded**.
- Check that the mains and motor cables **comply with the requirements** given in chapter 4.1.1.
- Check that the control cables are **located as far as possible** from the power cables, see chapter 4.3.
- Check that the **shields** of the shielded cables are **connected to protective earth** marked with .
- Check the **tightening torques** of all terminals
- Check that the **wires do not touch** the electrical components of the drive.
- Check that the common inputs of digital input groups are connected to +24V or ground of the I/O terminal or the external supply.
- Check the **quality and quantity** of cooling air (chapter 3.2 and Table 12).
- Check the inside of the drive for **condensation**.
- Check that all Start/Stop switches connected to the I/O terminals are in Stop-position.
- Before connecting the drive to mains: Check **mounting and condition** of all fuses and other protective devices.
- Run the Startup Wizard (see the Application Manual).

## 6.2 Running the motor

### MOTOR RUN CHECK LIST



**Before starting the motor**, check that the motor is **mounted properly** and ensure that the machine connected to the motor allows the motor to be started.



Set the maximum motor speed (frequency) according to the motor and the machine connected to it.



**Before reversing the motor** make sure that this can be done safely.



Make sure that no power correction capacitors are connected to the motor cable.



Make sure that the motor terminals are not connected to mains potential.

### 6.2.1 Cable and motor insulation checks

#### 1. Motor cable insulation checks

Disconnect the motor cable from terminals U, V and W of the drive and from the motor. Measure the insulation resistance of the motor cable between each phase conductor as well as between each phase conductor and the protective ground conductor. The insulation resistance must be  $>1\text{M}\Omega$  at ambient temperature of  $20^\circ\text{C}$ .

#### 2. Mains cable insulation checks

Disconnect the mains cable from terminals L1, L2 and L3 of the drive and from the mains. Measure the insulation resistance of the mains cable between each phase conductor as well as between each phase conductor and the protective ground conductor. The insulation resistance must be  $>1\text{M}\Omega$  at ambient temperature of  $20^\circ\text{C}$ .

### 3. Motor insulation checks

Disconnect the motor cable from the motor and open the bridging connections in the motor connection box. Measure the insulation resistance of each motor winding. The measurement voltage must equal at least the motor nominal voltage but not exceed 1000 V. The insulation resistance must be  $>1\text{M}\Omega$  at ambient temperature of  $20^{\circ}\text{C}$ . Always follow the instructions of the motor manufacturer.

### 6.3 Installation in IT system

If your supply network is an IT (impedance-grounded) system but your drive is EMC-protected according to class C2 you need to modify the EMC protection of the drive to EMC-level C4. This is done by removing the built-in EMC jumpers with a simple procedure described below.

**NOTE:** Honeywell SmartDrive HVAC 230V products with letter 'T' in the end of the product code (HVAC230-xxx-xxT) are as standard configured to IT-networks and do not need any modifications.

	<p>Warning! Do not perform any modifications on the drive when it is connected to mains.</p>
---	--

#### 6.3.1 Frames MR4 to MR6

1	<p>Remove the main cover of the drive (see pages 28 and 34) and locate the jumpers connecting the built-in RFI-filters to ground. See Figure 51. and Figure 52.</p>
---	---

**NOTE:** The locations of the EMC-jumpers have changed in frames MR5 and MR6. Figure 51. shows the old locations and Figure 52. the new locations in frames MR5 and MR6.

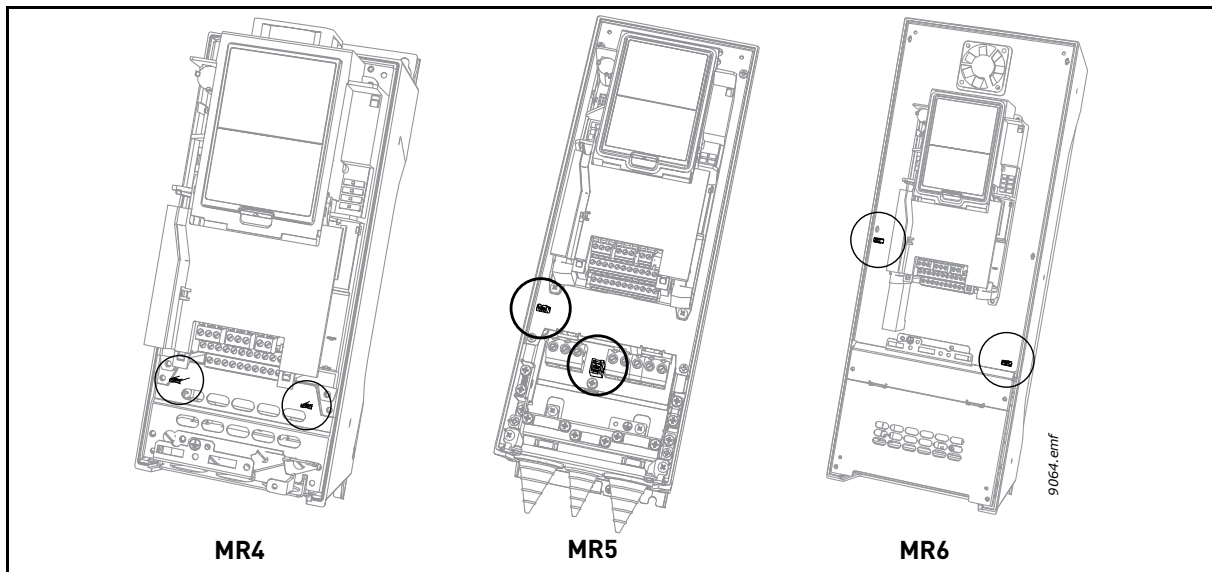

Figure 51. Current locations of the EMC-jumpers in frame MR4, old locations in frames MR5 and MR6



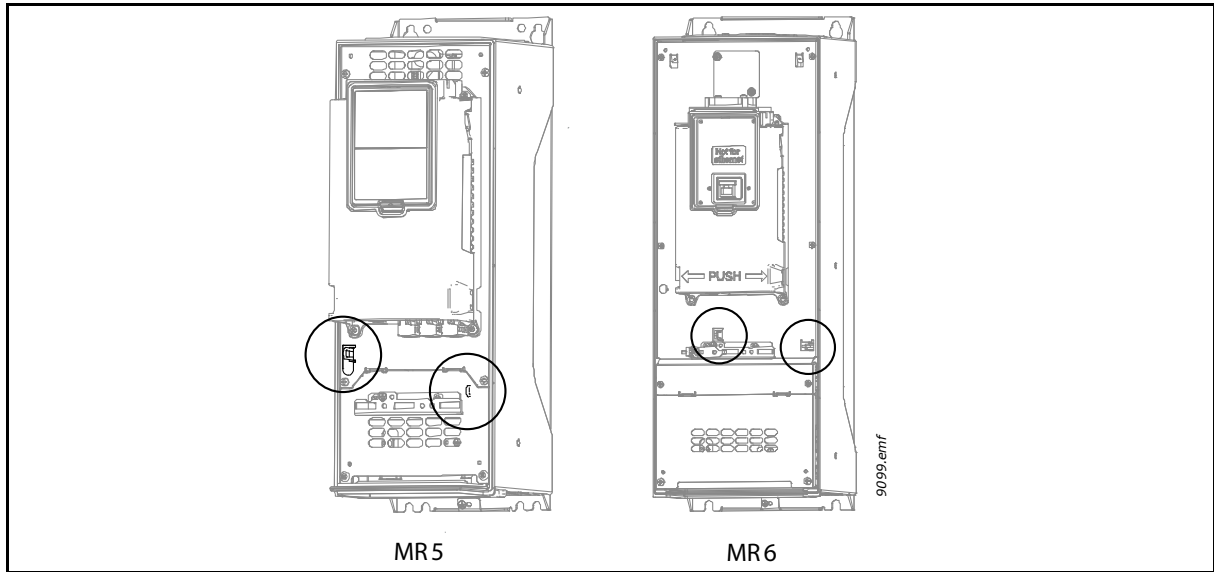

Figure 52. Current locations of the EMC-jumpers in frames MR5 and MR6

**2** Disconnect the RFI-filters from ground by removing the EMC-jumpers using long-nose pliers or similar. See Figure 53.

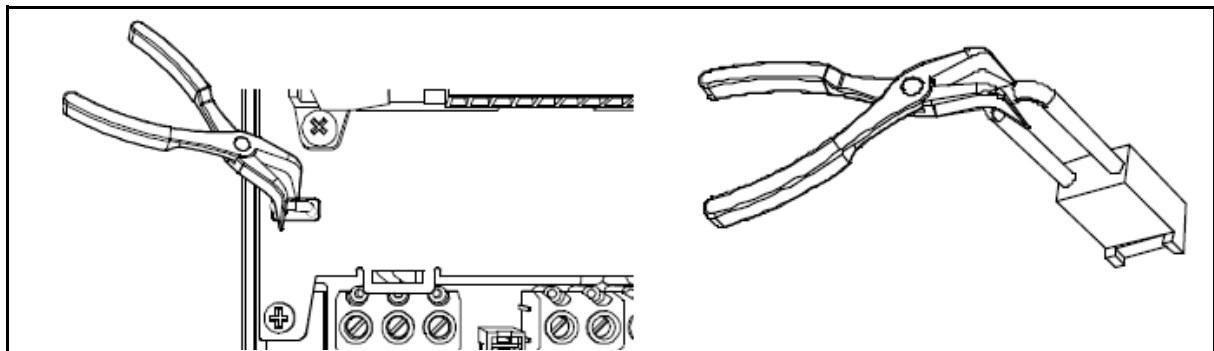

Figure 53. Removing the jumper, MR5 as example

### 6.3.2 Frames MR7 and MR8

Follow the procedure described above to modify the EMC protection of the drive of frames MR7 and MR8 to EMC-level C4.

- 1** Remove the main cover of the drive and locate the jumper. **MR8 only:** Push down the grounding arm. See Figure 54.

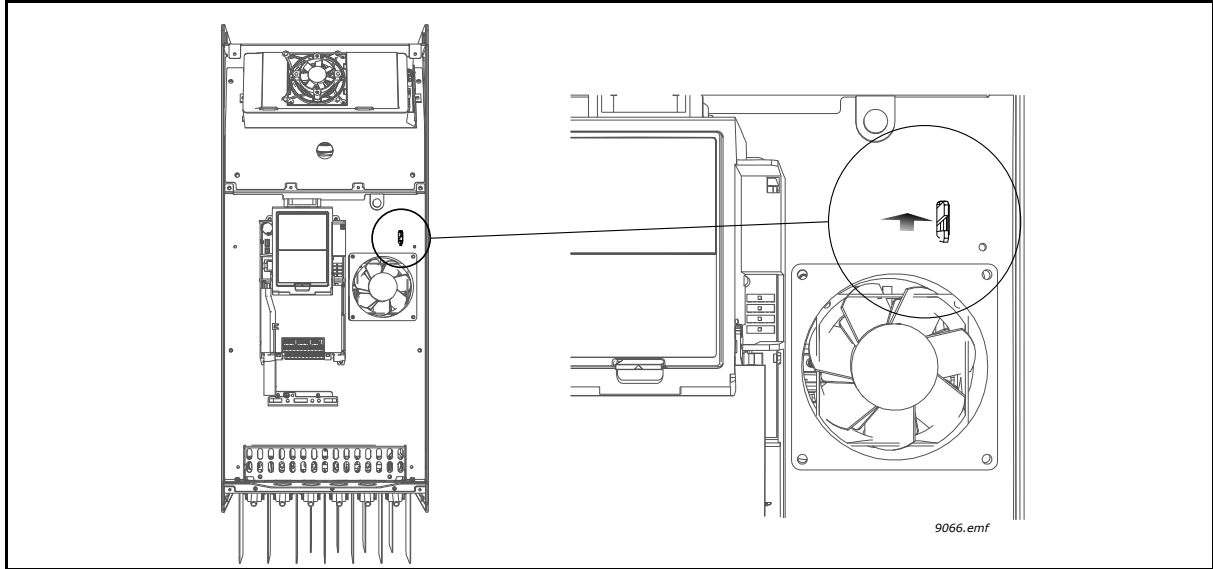

Figure 54.

- 2** **MR7 and MR8:** Locate the EMC box under the cover. Remove the screws of the box cover to expose the EMC-jumper. Detach the jumper and re-fix the box cover.

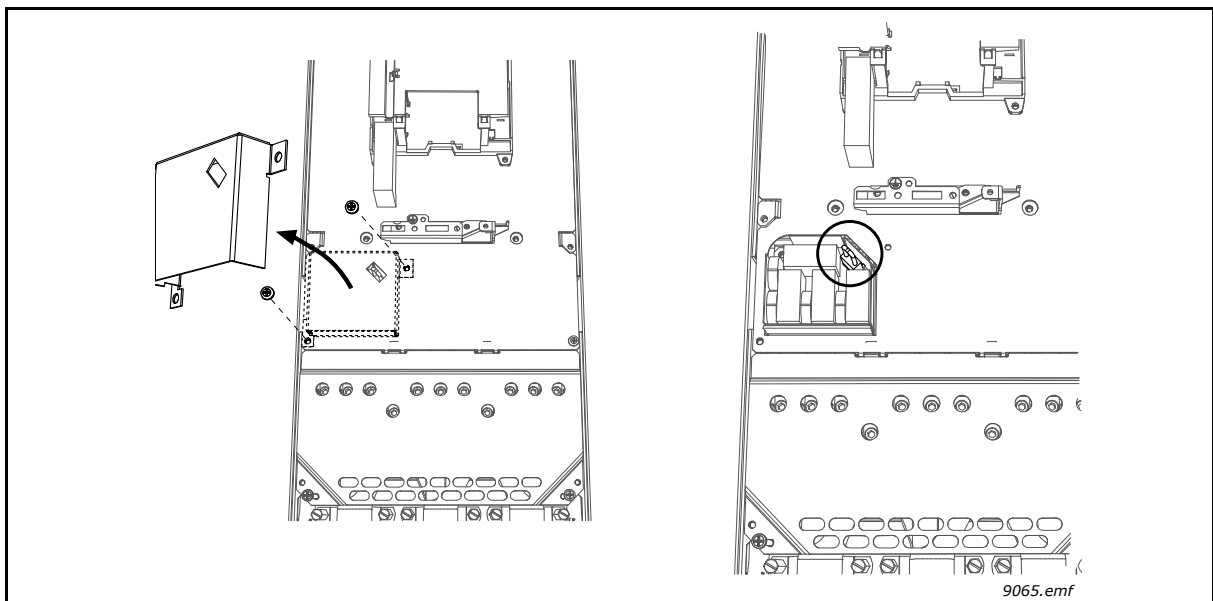

Figure 55.

**3** **MR7 only:** locate the DC grounding busbar between connectors R- and U and detach the busbar from the frame by undoing the M4 screw.

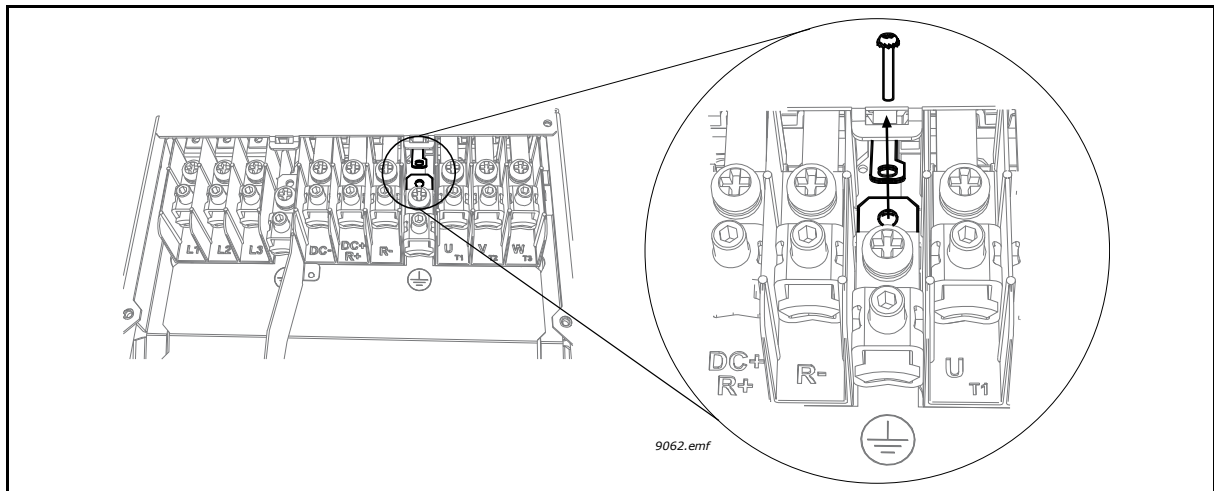

Figure 56. MR7: Detaching the DC grounding busbar from frame

**6.3.3 Frame MR9**

Follow the procedure described below to modify the EMC protection of the drive of frame MR9 to EMC-level C4.

**1** Find the *Molex* connector in the accessories bag. Remove the main cover of the drive and locate the place for the connector next to the fan. Push the Molex connector in its place. See Figure 57.

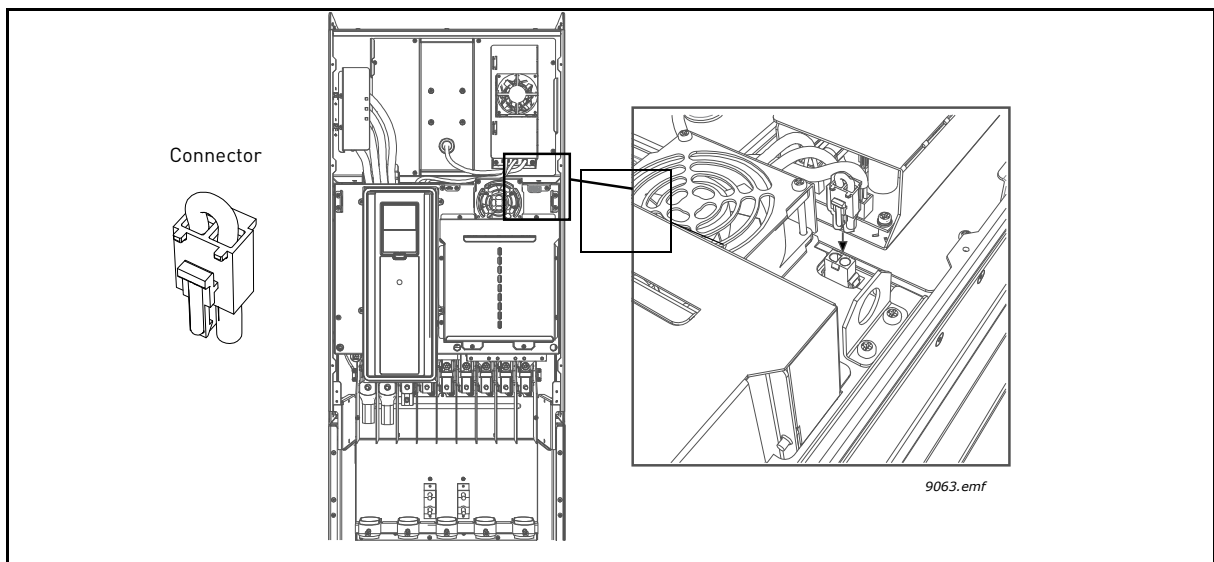

Figure 57.

<b>2</b>	Further remove the extension box cover, the touch shield the I/O plate with I/O grommet plate. Locate the EMC jumper on the EMC board (see magnification below) and remove it.
----------	--

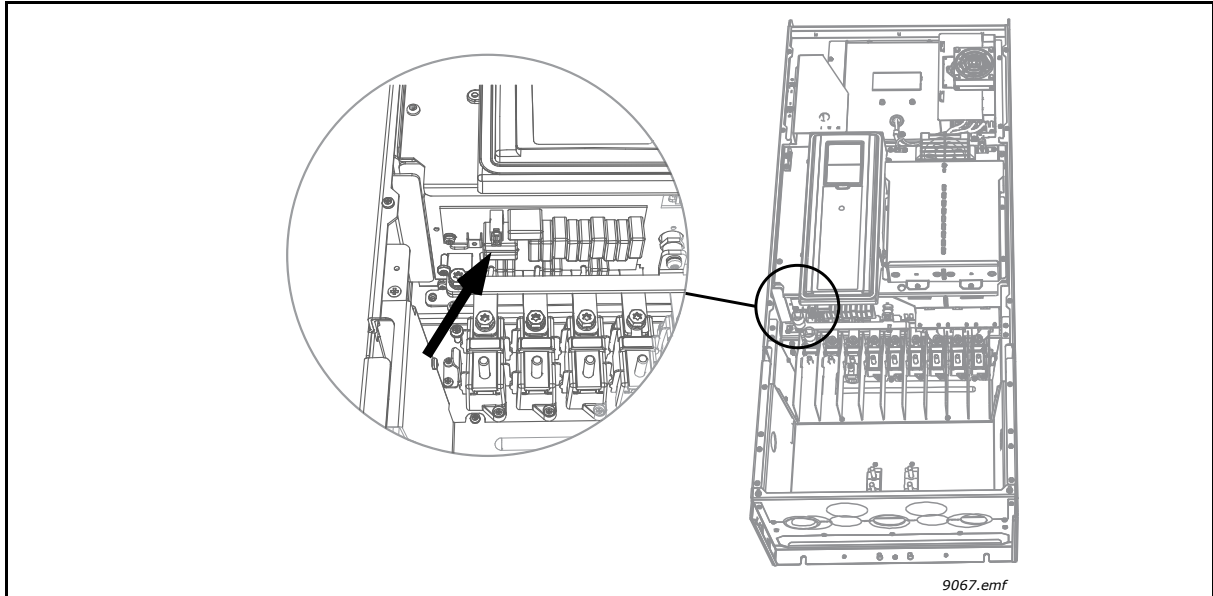

Figure 58.

	<p><b>CAUTION!</b> Before connecting the drive to mains make sure that the EMC protection class settings of the drive are appropriately made.</p>
	<p><b>NOTE!</b> After having performed the change write 'EMC level modified' on the sticker included in the delivery (see below) and note the date. Unless already done, attach the sticker close to the name plate the drive.</p> <div style="border: 1px solid black; padding: 5px; margin: 10px auto; width: fit-content;"> <p style="text-align: center;"><b>Product modified</b></p> <p style="text-align: right;">Date: .....</p> <p style="text-align: right;">Date: .....</p> <p>EMC-level modified C2-&gt;T... Date:DDMMYY </p> </div>

9005.emf

## 6.4 Maintenance

In normal conditions, the drive is maintenance-free. However, regular maintenance is recommended to ensure a trouble-free operation and a long lifetime of the drive. We recommend to follow the table below for maintenance intervals.

**NOTE:** Because of capacitor type (thin film capacitors), reforming of capacitors is not necessary.

Maintenance interval	Maintenance action
Regularly and according to general maintenance interval	<ul style="list-style-type: none"> <li>• Check tightening torques of terminals</li> <li>• Check filters</li> </ul>
6...24 months (depending on environment)	<ul style="list-style-type: none"> <li>• Check input and output terminals and control I/O terminals.</li> <li>• Check operation of cooling fan</li> <li>• Check for corrosion on terminals, bus-bars and other surfaces</li> <li>• Check door filters in case of cabinet installation</li> </ul>
24 months	<ul style="list-style-type: none"> <li>• Clean heatsink and cooling tunnel</li> </ul>
3...6 years	<ul style="list-style-type: none"> <li>• Change internal IP54 fan</li> </ul>
6...10 years	<ul style="list-style-type: none"> <li>• Change main fan</li> </ul>

## 7. TECHNICAL DATA

### 7.1 Drive power ratings

#### 7.1.1 Mains voltage 208-240 V

Mains voltage 208-240V, 50-60 Hz, 3~						
Product type	Loadability			Motor shaft power		
	Low*			230 supply	208-240V supply	
	Rated continuous current $I_L$ [A]	Input current $I_{in}$ [A]	10% overload current [A]	10% overload 40°C [kW]	10% overload 40°C [hp]	
<b>MR4</b>	230 P55	<b>3.7</b>	3.2	4.1	<b>0.55</b>	<b>0.75</b>
	230 P75	<b>4.8</b>	4.2	5.3	<b>0.75</b>	<b>1.0</b>
	230 1P1	<b>6.6</b>	6.0	7.3	<b>1.1</b>	<b>1.5</b>
	230 1P5	<b>8.0</b>	7.2	8.8	<b>1.5</b>	<b>2.0</b>
	230 2P2	<b>11.0</b>	9.7	12.1	<b>2.2</b>	<b>3.0</b>
	230 3P0	<b>12.5</b>	10.9	13.8	<b>3.0</b>	<b>4.0</b>
<b>MR5</b>	230 4P0	<b>18.0</b>	16.1	19.8	<b>4.0</b>	<b>5.0</b>
	230 5P5	<b>24.2</b>	21.7	26.4	<b>5.5</b>	<b>7.5</b>
	230 7P5	<b>31.0</b>	27.7	34.1	<b>7.5</b>	<b>10.0</b>
<b>MR6</b>	230 11P	<b>48.0</b>	43.8	52.8	<b>11.0</b>	<b>15.0</b>
	230 15P	<b>62.0</b>	57.0	68.2	<b>15.0</b>	<b>20.0</b>
<b>MR7</b>	230 18P	<b>75.0</b>	69.0	82.5	<b>18.5</b>	<b>25.0</b>
	230 22P	<b>88.0</b>	82.1	96.8	<b>22.0</b>	<b>30.0</b>
	230 30P	<b>105.0</b>	99.0	115.5	<b>30.0</b>	<b>40.0</b>
<b>MR8</b>	230 37P	<b>143.0</b>	135.1	154.0	<b>37.0</b>	<b>50.0</b>
	230 45P	<b>170.0</b>	162.0	187.0	<b>45.0</b>	<b>60.0</b>
	230 55P	<b>208.0</b>	200.0	225.5	<b>55.0</b>	<b>75.0</b>
<b>MR9</b>	230 75P	<b>261.0</b>	253.0	287.1	<b>75.0</b>	<b>100.0</b>
	230 90P	<b>310.0</b>	301.0	341.0	<b>90.0</b>	<b>125.0</b>

\* See chapter 7.1.3.

Table 28. Power ratings, supply voltage 208-240V.

**NOTE:** The rated currents in given ambient temperatures (in Table 30) are achieved only when the switching frequency is equal to or less than the factory default.

7.1.2 Mains voltage 380-480 V

<b>Mains voltage 380-480V, 50-60 Hz, 3~</b>						
Product type	Loadability			Motor shaft power		
	Low*			400V supply	480V supply	
	Rated continuous current $I_L$ [A]	Input current $I_{in}$ [A]	10% overload current [A]	10% overload 40°C [kW]	10% overload 40°C [HP]	
<b>MR4</b>	400 1P1	<b>3.4</b>	3.4	3.7	<b>1.1</b>	<b>1.5</b>
	400 1P5	<b>4.8</b>	4.6	5.3	<b>1.5</b>	<b>2.0</b>
	400 2P2	<b>5.6</b>	5.4	6.2	<b>2.2</b>	<b>3.0</b>
	400 3P0	<b>8.0</b>	8.1	8.8	<b>3.0</b>	<b>5.0</b>
	400 4P0	<b>9.6</b>	9.3	10.6	<b>4.0</b>	<b>5.0</b>
	400 5P5	<b>12.0</b>	11.3	13.2	<b>5.5</b>	<b>7.5</b>
<b>MR5</b>	400 7P5	<b>16.0</b>	15.4	17.6	<b>7.5</b>	<b>10</b>
	400 11P	<b>23.0</b>	21.3	25.3	<b>11.0</b>	<b>15.0</b>
	400 15P	<b>31.0</b>	28.4	34.1	<b>15.0</b>	<b>20.0</b>
<b>MR6</b>	400 18P	<b>38.0</b>	36.7	41.8	<b>18.5</b>	<b>25.0</b>
	400 22P	<b>46.0</b>	43.6	50.6	<b>22.0</b>	<b>30.0</b>
	400 30P	<b>61.0</b>	58.2	67.1	<b>30.0</b>	<b>40.0</b>
<b>MR7</b>	400 37P	<b>72.0</b>	67.5	79.2	<b>37.0</b>	<b>50.0</b>
	400 45P	<b>87.0</b>	85.3	95.7	<b>45.0</b>	<b>60.0</b>
	400 55P	<b>105.0</b>	100.6	115.5	<b>55.0</b>	<b>75.0</b>
<b>MR8</b>	400 75P	<b>140.0</b>	139.4	154.0	<b>75.0</b>	<b>100.0</b>
	400 90P	<b>170.0</b>	166.5	187.0	<b>90.0</b>	<b>125.0</b>
	400 110	<b>205.0</b>	199.6	225.5	<b>110.0</b>	<b>150.0</b>
<b>MR9</b>	400 132	<b>261.0</b>	258.0	287.1	<b>132.0</b>	<b>200.0</b>
	400 160	<b>310.0</b>	303.0	341.0	<b>160.0</b>	<b>250.0</b>

\* See chapter 7.1.3

Table 29. Power ratings, supply voltage 380-480V.

**NOTE:** The rated currents in given ambient temperatures (in Table 30) are achieved only when the switching frequency is equal to or less than the factory default.

**7.1.3 Definitions of overloadability**

**Low overload** =Following continuous operation at rated output current  $I_L$ , the converter is fed with  $110\% * I_L$  for 1 min, followed by a period of  $I_L$ .

Example: If the duty cycle requires  $110\%$  rated current  $I_L$  for 1 min in every 10 min, the remaining 9 min must be at rated current or less.

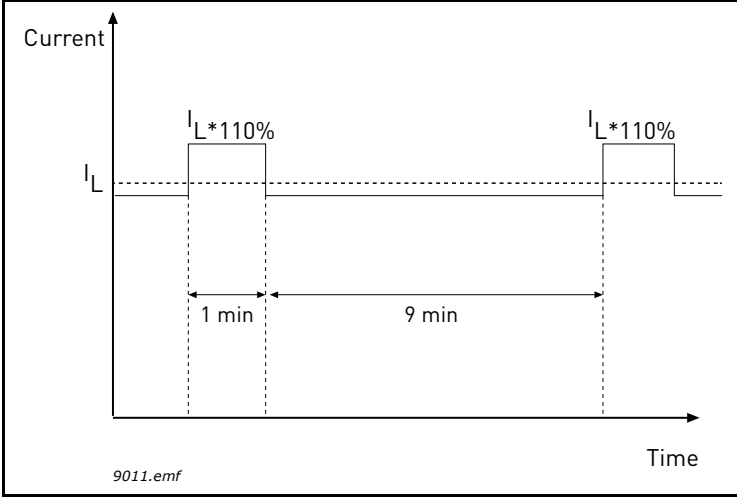

Figure 59. Low overload



## 7.2 Technical data

<b>Mains connection</b>	Input voltage $U_{in}$	208...240V; 380...480V; -10%...+10%
	Input frequency	50...60 Hz -5...+10%
	Connection to mains	Once per minute or less
	Starting delay	4 s (MR4 to MR6); 6 s (MR7 to MR9)
<b>Motor connection</b>	Output voltage	$0-U_{in}$
	Continuous output current	$I_L$ : Ambient temperature max. +40°C, up to +50°C with derating; overload $1.1 \times I_L$ (1 min./10 min.)
	Output frequency	0...320 Hz (standard)
	Frequency resolution	0.01 Hz
<b>Control characteristics</b>	Switching frequency (see parameter M3.1.2.1)	1.5...10 kHz; Defaults: <b>MR4-6</b> : 6 kHz (except 230 3P0, 230 7P5, 230 15P, 400 5P5, 400 15P and 400 30P: 4 kHz) <b>MR7</b> : 4 kHz <b>MR8-9</b> : 3 kHz Automatic adjustment of switching frequency by overtemperature ride-through function in case of overload, e.g. short-time ambient temperature increase.
	<u>Frequency reference</u>	
	Analogue input	Resolution 0.1% (10-bit), accuracy $\pm 1\%$
	Panel reference	Resolution 0.01 Hz
	Field weakening point	8...320 Hz
	Acceleration time	0.1...3000 sec
Deceleration time	0.1...3000 sec	

<b>Ambient conditions</b>	Ambient operating temperature	$I_L$ : -10°C (no frost)...+40°C; up to +50°C with derating
	Storage temperature	-40°C...+70°C
	Relative humidity	0...95% RH, non-condensing, non-corrosive
	Air quality: • chemical vapours • mechanical particles	<b>Tested</b> according to IEC 60068-2-60 Test Ke: Flowing mixed gas corrosion test, Method 1 (H <sub>2</sub> S [hydrogen sulfide] and SO <sub>2</sub> [sulfur dioxide]) <b>Designed</b> according to: IEC 60721-3-3, unit in operation, class 3C2 IEC 60721-3-3, unit in operation, class 3S2
Altitude	100% load capacity (no derating) up to 1,000 m 1-% derating for each 100m above 1,000m <u>Max. altitudes:</u> <b>208...240V:</b> 4,500m (TN and IT systems) <b>380...480V:</b> 4,500m (TN and IT systems) <u>Voltage for I/O signals:</u> Up to 2,000m : Allowed up to <b>240V</b> 2,000m...4,500m: Allowed up to <b>120V</b> <u>Corner-grounding:</u> up to 2,000m only.	
<b>Ambient conditions (cont.)</b>	Vibration EN61800-5-1/ EN60068-2-6	5...150 Hz <b>Displacement amplitude</b> 1 mm (peak) at 5...15.8 Hz (MR4...MR9) <b>Max acceleration amplitude</b> 1 G at 15.8...150 Hz (MR4...MR9)
	Shock EN61800-5-1 EN60068-2-27	UPS Drop Test (for applicable UPS weights) Storage and shipping: max 15 G, 11 ms (in package)
	Enclosure class	IP21/NEMA1 (HVACxxx-xxx-21) IP54/NEMA12 (HVACxxx-xxx-54) Note! Keypad required for IP54/Type 12
<b>EMC (at default settings)</b>	Immunity	Fulfils EN61800-3 (2004), first and second environment
	Emissions	EN61800-3 (2004), Category C2 The drive can be modified for IT-networks. See chapter 6.3.
<b>Noise level</b>	Average noise level (cooling fan) sound power level in dB(A)	MR4: 65      MR7: 77 MR5: 70      MR8: 86 MR6: 77      MR9: 87
<b>Safety</b>		EN 61800-5-1 (2007), CE, cUL; (see unit nameplate for more detailed approvals)

<b>Protections</b>	Overvoltage trip limit	240-volt drives: <b>456 VDC</b> 480-volt drives: <b>911 VDC</b>
	Undervoltage trip limit	Depends on supply voltage (0,8775*supply voltage): Supply voltage 240 V: Trip limit <b>211 VDC</b> Supply voltage 400 V: Trip limit <b>351 VDC</b> Supply voltage 480 V: Trip limit <b>421 VDC</b>
	Earth fault protection	Yes
	Mains supervision	Yes
	Motor phase supervision	Yes
	Overcurrent protection	Yes
	Unit overtemperature protection	Yes
	Motor overload protection	Yes
	Motor stall protection	Yes
	Motor underload protection	Yes
	Short-circuit protection of +24VDC and +10VDC reference voltages	Yes

Table 30. Technical data

## 7.2.1 Technical information on control connections

Standard I/O board		
Terminal	Signal	Technical information
1	Reference output	+10VDC, +3%; Maximum current 10 mA
2	Analogue input, voltage or current	Analogue input channel 1; Short-circuited protected 0- +10VDC ( $R_i = 200 \text{ k}\Omega$ ) 4-20 mA ( $R_i = 250 \text{ }\Omega$ ) Resolution 0.1 %, accuracy $\pm 1$ % Selection V/mA with dip-switches (see page 47)
3	Analogue input common (current)	Differential input if not connected to ground; Allows $\pm 20\text{V}$ differential mode voltage to GND
4	Analogue input, voltage or current	Analogue input channel 2; Short-circuited protected Default:4-20 mA ( $R_i = 250 \text{ }\Omega$ ) 0-10 VDC ( $R_i = 200 \text{ k}\Omega$ ) Resolution 0.1 %, accuracy $\pm 1$ % Selection V/mA with dip-switches (see page 47)
5	Analogue input common (current)	Differential input if not connected to ground; Allows 20V differential mode voltage to GND
6	24VDC aux. voltage	+24VDC, $\pm 10\%$ , max volt. ripple < 100mVrms; max. 250mA Dimensioning: max. 1000mA/control unit. Short-circuit protected
7	I/O ground	Ground for reference and controls (connected internally to frame earth through $1 \text{ M}\Omega$ )
8	Digital input 1	Positive or negative logic $R_i = \text{min. } 5 \text{ k}\Omega$ 0...5VDC = "0" 15...30VDC = "1"
9	Digital input 2	
10	Digital input 3	
11	Common A for DIN1-DIN6.	Digital inputs can be disconnected from ground, see chapter 5.1.2.2.
12	24VDC aux. voltage	+24VDC, $\pm 10\%$ , max volt. ripple < 100mVrms; max. 250mA Dimensioning: max. 1000mA/control unit. Short-circuit protected
13	I/O ground	Ground for reference and controls (connected internally to frame earth through $1 \text{ M}\Omega$ )
14	Digital input 4	Positive or negative logic $R_i = \text{min. } 5 \text{ k}\Omega$ 0...5VDC = "0" 15...30VDC = "1"
15	Digital input 5	
16	Digital input 6	
17	Common A for DIN1-DIN6.	Digital inputs can be isolated from ground, see chapter 5.1.2.2.
18	Analogue signal (+output)	Analogue output channel 1, selection 0 -20mA, load <500 $\Omega$ Default:0-20 mA/0-10VDC Resolution 0.1 %, accuracy $\pm 2$ % Selection V/mA with dip-switches (see page 47) Short-circuited protected.
19	Analogue output common	
30	24VDC auxiliary input voltage	Can be used to power the control unit (e.g. UPS, battery). +24VDC, $\pm 10\%$ ; max. 1000mA
A	RS485	Differential receiver/transmitter
B	RS485	Set bus termination with dip switches (see page 47)

Table 31. Technical information on standard I/O board

<b>Relay board</b>		Relay board with two change-over contact (SPDT) relays and one relay with normally-open (NO or SPST) contact. 5,5 mm isolation between channels.
<b>21</b>	Relay output 1*	Switching capacity 24VDC/8A
<b>22</b>		250VAC/8A
<b>23</b>		125VDC/0.4A
<b>24</b>	Relay output 2*	Min. switching load 5V/10mA
<b>25</b>		Switching capacity 24VDC/8A
<b>26</b>		250VAC/8A
<b>28</b>	Thermistor input	125VDC/0.4A
<b>29</b>		Min. switching load 5V/10mA
		Rtrip = 4.7 k $\Omega$ (PTC); Measuring voltage 3.5V

\* If 230VAC is used as control voltage from the output relays, the control circuitry must be powered with a separate isolation transformer to limit short circuit current and overvoltage spikes. This is to prevent welding on the relay contacts. Refer to standard EN 60204-1, section 7.2.9

*Table 32. Technical information on Relay board*





DPD00487E

Manufactured for and on behalf of the Environmental and Combustion Controls Division of Honeywell Technologies Sàrl, Rolle, Z.A. La Pièce 16, Switzerland by its Authorized Representative:

Subject to change without notice.

Automation and Control Solutions  
Honeywell GmbH  
Böblinger Strasse 17  
71101 Schönaich  
Germany  
Phone (49) 7031 63701  
Fax (49) 7031 637493  
<http://ecc.emea.honeywell.com>

EN1B-0489GE51 R0114

January 2014

© 2014 Honeywell International Inc.

**Honeywell**