



VPI PRESSURE INDEPENDENT CONTROL VALVES AND ACTUATORS

INSTALLATION INSTRUCTION



31-00383-02

Proper Use

These valves are intended for use in chilled water and hot water closed-loop applications only, with a media temperature range of -20°C to $+120^{\circ}\text{C}$ (-4°F to $+248^{\circ}\text{F}$), and static pressures up to 580psi. Not suitable for oil, combustible gases, or high-temperature steam.

These valves are to be operated with the appropriate and compatible Honeywell actuators only. Refer VPI series PICV Product Datasheets for more details on valve and actuators compatibility.

Water should be properly filtered, treated, and conditioned for good operating performance, and according to VDI 2035 with up to 50 % Glycol (oxygen concentration less than 0.2 g/m^3 , pH 8...9.5; $\text{Fe}<0.5\text{ mg/kg}$; $\text{Cu}<0.1\text{ mg/kg}$). The installation of strainers and filters is recommended. Do not use manual balancing valves.

IMPORTANT: *The presence of excessive iron oxide (red rust) in the system voids the valve warranty.*

Effective Flow Rate

The built-in differential pressure regulator makes fluid flow through the valve independent of changes in supply. The pressure regulator virtually eliminates cavitation in the valve and decouples the control valve from the effects of piping components such as reducers and elbows.

Pressure independent control valves are sized to match design coil flow regardless of coil connection size. These valves eliminate the need to balance the system for proper flow and allow chillers to be operated at design temperature differential for maximum efficiency at every load condition.

Flow Characteristic

The VPI series Pressure Independent Control Valves have: Linear flow characteristic and can be converted to an equal percentage in the actuator.

APPLICATION

Honeywell pressure independent control valve (PICV) is used in heating and cooling systems in applications with Air Handling Units, Fan Coil Units, chilled ceilings, zone control, or other terminal unit applications. Honeywell VPI series provides modulating control with full authority regardless of any fluctuations in the differential pressure of the system. Honeywell VPI series combines an externally adjustable automatic balancing valve, a differential pressure control valve, and a full authority modulating control valve.

Honeywell VPI series makes it simple to achieve 100% control of the water flow in the building while creating high comfort and energy savings at the same time. An additional benefit is that no balancing is required if further stages are added to the system, or if the dimensioned capacity is changed. Energy-saving due to optimal control, lower flow, and pump pressure. Maximized ΔT due to faster response and increased system stability

Application Notes

Valve sizing is important for correct system operation. Undersized valves do not have sufficient capacity at maximum load.

DECLARATION OF REACH CONFORMITY

Article 33 Communication

REGULATION (EC) NO 1907/2006 [REACH]

According to Article 33 of Reach Regulation be informed that these products may contain lead (CAS: 7439-92-1) up to 2.0-2.5% in any brass used in valve housings, headnuts, p/t plugs, flushing caps etc.

PREREQUISITE

When installing this product...

1. Read these instructions carefully. Failure to follow them could damage the product or cause a hazardous condition.
2. Check ratings given in instructions and on the product to ensure the product is suitable for your application.
3. The installer must be a trained, experienced service technician.
4. After installation is complete, check out product operation as provided in these instructions.

Preparation



Equipment Damage Hazard

Foreign particles like dirt and metal chips can damage the valve seat and diaphragm.

For trouble-free operation of the product, good installation practice must include initial system flushing and chemical water treatment. Clean the lines upstream of particles larger than 1/16 inch diameter (welding slag, pipe scale, sand, and any other suspended particulate).

Do not use boiler additives, solder flux, and wetted materials which are petroleum-based or contain mineral oil, hydrocarbons, or ethylene glycol acetate. Compounds that can be used, with a minimum 50% water dilution, are diethylene glycol, ethylene glycol, and propylene glycol (antifreeze solutions).

If installing these valves in an addition to, or retrofitting an existing building, do not assume that the fluid in the existing piping meets these criteria.

1. Before installing the valves, flush the system.
2. It is recommended to install strainers in front of the valves to protect against clogging due to foreign particles. Strainer baskets should be installed, checked and cleaned as required during flushing and normal operation.
3. Use clean water according to the guidelines in VDI 2035. VDI 2035 recommends water quality as per conductance value <math><100 \mu\text{S}/\text{cm}</math>, oxygen content of up to 0.1 mg/l, pH of 8.2-10.0 and requires low turbidity <math><1\text{FTU}</math> and consequently low content of alkaline earths.
4. It is recommended to treat water with chemical to achieve required water quality. If using any additives, please contact Honeywell for guidance.

MECHANICAL INSTALLATION

Installation for DN15-32

IMPORTANT: Hold valve with a pipe wrench by hexagonal fitting **ONLY**. Do **NOT** handle the valve body with the pipe wrench; product damage may result.

Refer VPI series PICV Product Datasheets for more details on valve and actuator dimensions.

1. Clean the lines upstream of particles larger than 1/16 in. diameter (welding slag, pipe scale and other contaminants) to properly flush the system.
2. Proceed with installation once the system specifics (expansion/contraction of the system and its medium as well as operating pressures) are within tolerances.
3. Eliminate air from the system.
4. See, *Figure 1* to familiarize yourself with the valve and its components. The Valve body (D) is the housing marked with an arrow to show flow direction. The Flow regulator (C) which is pre-installed in valve body, regulates flow. Pressure ports (A) facilitates user to gauge pressure across ends. The Plugs (B) comes with valve models without pressure ports. See VPI series PICV Product Datasheets for details on models with and without pressure ports.

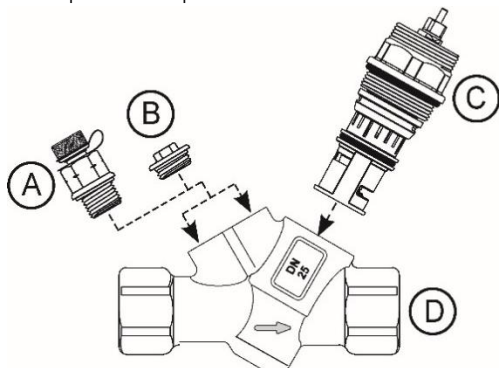

Figure 1. DN15-32 Valve Components

IMPORTANT: Flow arrow must point in the direction of the flow for proper operation. Valves must be installed avoiding unnecessary pull or twist in the valve housing.

5. Install the valve housing with the flow directional arrow pointing in the correct direction.
6. For threaded connections please clear threads on both valve and piping of debris. Honeywell recommends thread or pipe sealant (PermaBond A1044 or equivalent). When using Teflon tape, it is recommended to use 4-6 rounds of tape applied tightly in clockwise rotation. When using hemp as

pipe sealant, ensure no strands are left in the valve or piping.

Flow Setting

The Flow regulator is provisioned with dial with scale settings to allow user to set desired flow rate. For more information about flow rate as per dial settings, see *Table 1. Flow Chart for DN15-32*. The procedure for scale setting is as follows:

1. Set the desired flow rate by adjusting scale setting of the dial with a special adjustment key.

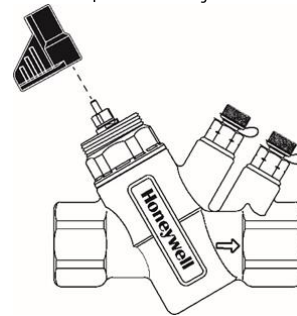

Figure 2 Flow Setting

2. For DN15/20 (LF) and DN32 valve models, large white digits, numbered 1 to 5, indicate full turns and digits from small sub-dial, numbered 0 to 9, indicate 1/10 of full turn.



Figure 3 Dial Gauge for DN 15/20 (LF) and DN32

3. For DN15/20/25 (HF) valve models, scale is opposite. Here large white digits, numbered 0 to 9, indicate 1/10 of full turn and small digits from sub-dial, numbered 0 to 5, indicate full turn.



Figure 4 Dial Gauge 3. For DN15/20/25 (HF)

4. Install the compatible and required actuator as per application and/or system design. See *Installation of Actuators compatible with DN 15-50* for more details on how to install the actuator.

Flow Setting Chart for DN 15 -32

Table 1. Flow Chart for DN15-32

DN15LF-DN20LF			DN15HF-DN25HF			DN32			Setting
l/sec	l/hr	GPM	l/sec	l/hr	GPM	l/sec	l/hr	GPM	
0.0178	64	0.282	-	-	-	0.240	865	3.81	1.0
0.0393	142	0.624	-	-	-	0.282	1010	4.46	1.1
0.0580	209	0.920	-	-	-	0.322	1160	5.10	1.2
0.0743	268	1.180	-	-	-	0.361	1300	5.72	1.3
0.0887	319	1.41	-	-	-	0.399	1430	6.32	1.4
0.102	366	1.61	0.172	620	2.73	0.435	1570	6.90	1.5
0.113	408	1.80	0.200	720	3.17	0.471	1700	7.47	1.6
0.124	446	1.96	0.228	820	3.61	0.506	1820	8.02	1.7
0.134	482	2.12	0.258	930	4.10	0.540	1940	8.56	1.8
0.143	516	2.27	0.294	1060	4.67	0.573	2060	9.08	1.9
0.152	549	2.42	0.325	1170	5.15	0.605	2180	9.59	2.0
0.161	580	2.56	0.350	1260	5.55	0.636	2290	10.1	2.1
0.170	611	2.69	0.375	1350	5.95	0.667	2400	10.6	2.2
0.178	641	2.82	0.396	1430	6.28	0.696	2510	11.0	2.3
0.186	671	2.95	0.417	1500	6.61	0.725	2610	11.5	2.4
0.194	700	3.08	0.439	1580	6.96	0.753	2710	11.9	2.5
0.202	728	3.21	0.458	1650	7.27	0.780	2810	12.4	2.6
0.210	756	3.33	0.481	1730	7.62	0.807	2900	12.8	2.7
0.218	783	3.45	0.500	1800	7.93	0.832	3000	13.2	2.8
0.225	810	3.56	0.522	1880	8.28	0.858	3090	13.6	2.9
0.232	835	3.68	0.542	1950	8.59	0.882	3180	14.0	3.0
0.239	860	3.79	0.550	1980	8.72	0.906	3260	14.4	3.1
0.245	883	3.89	0.558	2010	8.85	0.930	3350	14.7	3.2
0.252	906	3.99	0.567	2040	8.99	0.953	3430	15.1	3.3
0.257	927	4.08	0.575	2070	9.12	0.975	3510	15.5	3.4
0.263	946	4.17	0.583	2100	9.25	0.997	3590	15.8	3.5
0.268	965	4.25	0.597	2150	9.47	1.02	3670	16.1	3.6
0.273	982	4.32	0.611	2200	9.69	1.04	3740	16.5	3.7
0.277	998	4.39	0.625	2250	9.91	1.06	3820	16.8	3.8
0.281	1010	4.46	0.639	2300	10.1	1.08	3890	17.1	3.9
0.285	1020	4.51	0.653	2350	10.4	1.10	3960	17.4	4.0
0.288	1040	4.57	0.661	2380	10.5	1.12	4030	17.7	4.1
0.291	1050	4.61	0.669	2410	10.6	1.14	4100	18.1	4.2
0.294	1060	4.66	0.678	2440	10.7	1.16	4170	18.4	4.3

DN15LF-DN20LF			DN15HF-DN25HF			DN32			Setting
l/sec	l/hr	GPM	l/sec	l/hr	GPM	l/sec	l/hr	GPM	
0.296	1070	4.70	0.686	2470	10.9	1.18	4240	18.7	4.4
0.299	1080	4.73	0.694	2500	11.0	1.20	4300	19.0	4.5
0.301	1080	4.77	0.703	2530	11.1	1.21	4370	19.2	4.6
0.303	1090	4.80	0.711	2560	11.3	1.23	4440	19.5	4.7
0.305	1100	4.83	0.719	2590	11.4	1.25	4500	19.8	4.8
0.307	1100	4.86	0.728	2620	11.5	1.27	4570	20.1	4.9
0.308	1110	4.89	0.736	2650	11.7	1.29	4630	20.4	5.0

Replacement of Flow regulator

The Flow regulator are engineered and designed with more life span. Follow below procedures in case if the old flow regulator needs replacement with the new one.

Procedure to remove the Flow Regulator

The procedure to remove Flow Regulator is as follows:

1. Remove the installed actuator (if any) as stated in *Procedure to remove the Actuator*.
2. Isolate the valve.
3. Use the pipe wrench or appropriate tool to rotate Flow Regulator in counterclockwise direction to remove from the valve body. See *Figure 5*.

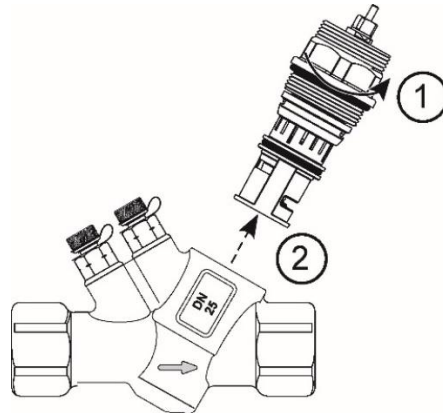

Figure 5. Removing Flow regulator from Valve body

Procedure to install the Flow Regulator

The procedure to install Flow Regulator is as follows:

1. Prior to installing the Flow regulator, the system should be properly flushed.
2. Insert the Flow Regulator in valve body and rotate with the pipe wrench or appropriate tool in Clockwise direction to fit flow regulator in valve body. Follow the reverse sequence of steps shown in Figure above.
3. Open isolation valves slowly. Fast opening of isolation valves under high pressure may cause damage to the seat or diaphragm of the Flow regulator.
4. Set the desired flow rate by adjusting the Flow Regulator with special adjustment key.
5. Install the actuator as stated in *Procedure to install the Actuator*.

Installation for DN40-50

IMPORTANT: Hold valve with a pipe wrench by hexagonal fitting **ONLY**. Do **NOT** handle the valve body with the pipe wrench; product damage may result.

Refer VPI series PICV Product Datasheets for more details on valve and actuator dimensions.

The procedure to install DN 40-50 valve is as follows:

1. Clean the lines upstream of particles larger than 1/16 in. diameter (welding slag, pipe scale and other contaminants) to properly flush the system.
2. Proceed with installation once the system specifics (expansion/contraction of the system and its medium as well as operating pressures) are within tolerances.
3. Eliminate air from the system.
4. See *Figure 6* to familiarize yourself with the valve and its components. The Valve Body (A) is the housing marked with an arrow to show flow direction. The Flow Regulator (B) which is fixed with valve body, regulates flow.

IMPORTANT: Do not disassemble or attempt to remove the Flow regulator from the valve body. Doing so may damage the valve and will void warranty.

Pressure ports (C) facilitates user to gauge pressure across ends. The Plugs (D) comes with valve models without pressure ports. See VPI series PICV Product Datasheets for more details on models with and without pressure ports.

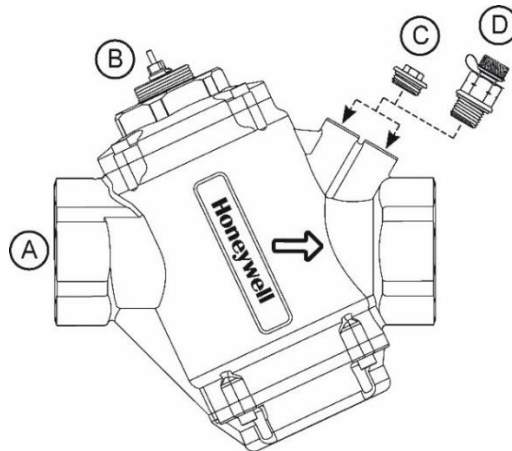

Figure 6 DN40-50 Valve Components

IMPORTANT: Flow arrows must point in the direction of the flow for proper operation.

5. Install the valve housing with the flow directional arrow pointing in the correct direction.
6. For threaded connections please clear threads on both valve and piping of debris. Honeywell recommends thread or pipe sealant (Permabond A1044 or equivalent). When using Teflon tape, it is recommended to use 4-6 rounds of tape applied tightly in clockwise rotation. When using hemp as pipe sealant, ensure no strands are left in the valve or piping.

IMPORTANT: Never use mineral oil or petrol-based grease or oil on the O-rings.

7. Set the desired flow rate by adjusting scale setting of the dial with a special adjustment key.

Flow Setting for DN40-50

The Flow regulator is provisioned with dial with scale settings to allow user to set desired flow rate. For more information about flow rate as per dial settings, see *Table 2. Flow Settings Chart for DN40-50*. The procedure for scale setting is as follows:

1. Set the desired flow rate by adjusting scale setting of the dial with a special adjustment key.

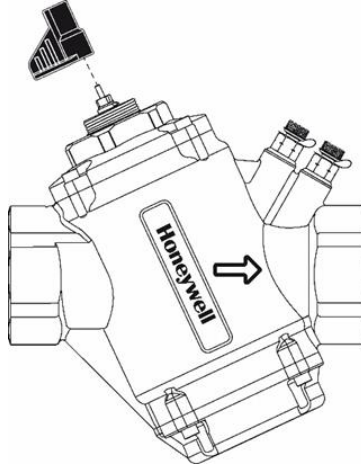

Figure 7 Flow setting for DN 40- 50

2. For DN40/50, large white digits numbered 1 to 5 including in-between positions showed by dots (one dot for every 0.1 positions). The specific position is defined by a sign mark on top of the housing.



Figure 8 Dial Gauge for DN 40- 50

3. Install the compatible and required actuator as per application and/or system design.

Flow Setting Chart for DN40 – DN50

Table 2. Flow Settings Chart for DN40-50

DN40-DN50			Setting
l/sec	l/hr	GPM	
0.528	1900	8.36	1.0
0.633	2278	10.0	1.1
0.738	2655	11.7	1.2
0.843	3033	13.3	1.3
0.947	3410	15.0	1.4
1.05	3787	16.7	1.5
1.16	4163	18.3	1.6
1.26	4537	20.0	1.7
1.36	4909	21.6	1.8
1.47	5279	23.2	1.9
1.57	5646	24.8	2.0
1.67	6011	26.4	2.1
1.77	6372	28.0	2.2
1.87	6730	29.6	2.3
1.97	7083	31.2	2.4
2.06	7432	32.7	2.5
2.16	7776	34.2	2.6
2.25	8115	35.7	2.7
2.35	8449	37.2	2.8
2.44	8777	38.6	2.9
2.53	9098	40.0	3.0
2.61	9413	41.4	3.1
2.70	9721	42.8	3.2
2.78	10021	44.1	3.3
2.86	10314	45.4	3.4
2.94	10599	46.6	3.5
3.02	10875	47.8	3.6
3.10	11142	49.0	3.7
3.17	11400	50.2	3.8
3.24	11649	51.3	3.9
3.30	11888	52.3	4.0
3.37	12116	53.3	4.1
3.43	12334	54.3	4.2
3.48	12540	55.2	4.3
3.54	12735	56.0	4.4
3.59	12919	56.8	4.5
3.64	13090	57.6	4.6
3.68	13249	58.3	4.7
3.72	13395	58.9	4.8
3.76	13527	59.5	4.9
3.79	13647	60.0	5.0

Installation of DN50-250

Refer VPI series PICV Product Datasheets for more details on valve and actuator dimensions.

The procedure to install for DN 50 – 250 is as follows:

1. Clean the lines upstream of particles larger than 1/16 in. diameter (welding slag, pipe scale, and other contaminants) to properly flush the system.
2. Proceed with installation once the system specifics (expansion/contraction of the system and its medium as well as operating pressures) are within tolerances.
3. Eliminate air from the system.
4. Valves are marked to show flow direction, see Figure 9. Install the valve housing with the flow directional arrow pointing in the correct direction.

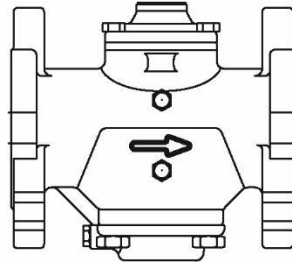

Figure 9. Flow direction icon on DN50-250 valve

IMPORTANT: Flow arrows must point in the direction of the flow for proper operation.

5. Valves must be installed avoiding unnecessary pull or twist in the valve housing.
6. For flanged connections make sure if both flange surfaces are clear.
7. Flange ends are compatible with DIN steel flanges PN10, PN16, PN25, and/or PN40 according to EN1092-1 or ANSI steel flanges class 150 and/ or 300 according to ASME B16.5. depending on the product ordered. Flanges are not supplied by Honeywell.

See VPI series PICV Product Datasheets for more details on the flange selection of DN50-250 valves.

NOTE: DN150HF model requires flange adapter from DN200 to DN150 (available as an accessory).

8. O-rings are supplied with the valve body and are used to seal connections. It is recommended to grease O-rings with silicone grease.

IMPORTANT: Never use mineral oil or petrol-based grease or oil on the O-rings.

9. Please make sure these are properly placed in O-ring grooves on valve inlet and outlet, before installing the housing.
10. Please note that DN200-250 (8"-10") contains two O-ring grooves. Use the inner groove for DN200 / 8" flanges and outer groove for DN250 / 10" flanges.

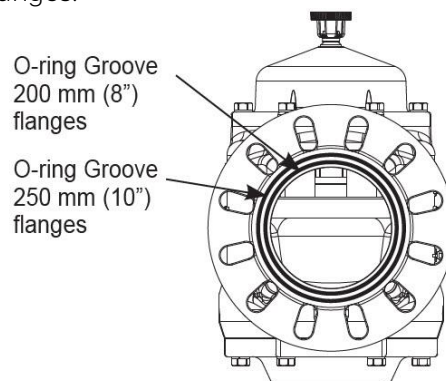

Figure 10. Groove location on DN200-250 valve

Install the compatible and required actuator as per application and/or system design. See *Installation of Actuators compatible with DN50 – 250* for more details on how to install the actuator.

Flow Setting Chart for DN50-100

Table 3. Flow Setting Chart for DN50-100

DN50			DN65			DN80LF			DN80HF			DN100LF			DN100HF		
l/sec	l/hr	GPM	l/sec	l/hr	GPM	l/sec	l/hr	GPM	l/sec	l/hr	GPM	l/sec	l/hr	GPM	l/sec	l/hr	GPM
2.57	9240	40.7	2.57	9240	40.7	3.55	12800	56.3	4.73	17000	75.0	4.73	17000	75.0	3.68	13300	58.3
2.81	10100	44.6	2.81	10100	44.6	3.85	13900	61.0	5.29	19000	83.8	5.29	19000	83.8	4.42	15900	70.0
3.05	11000	48.3	3.05	11000	48.3	4.13	14900	65.5	5.82	21000	92.3	5.82	21000	92.3	5.13	18500	81.3
3.27	11800	51.9	3.27	11800	51.9	4.41	15900	69.9	6.33	22800	100	6.33	22800	100	5.82	21000	92.3
3.49	12500	55.2	3.49	12500	55.2	4.67	16800	74.0	6.82	24500	108	6.82	24500	108	6.50	23400	103
3.69	13300	58.4	3.69	13300	58.4	4.92	17700	78.0	7.28	26200	115	7.28	26200	115	7.15	25700	113
3.88	14000	61.5	3.88	14000	61.5	5.16	18600	81.7	7.72	27800	122	7.72	27800	122	7.78	28000	123
4.06	14600	64.3	4.06	14600	64.3	5.38	19400	85.3	8.14	29300	129	8.14	29300	129	8.40	30200	133
4.23	15200	67.0	4.23	15200	67.0	5.60	20200	88.8	8.54	30700	135	8.54	30700	135	8.99	32400	142
4.39	15800	69.6	4.39	15800	69.6	5.81	20900	92.1	8.91	32100	141	8.91	32100	141	9.57	34400	152
4.54	16300	72.0	4.54	16300	72.0	6.01	21600	95.2	9.27	33400	147	9.27	33400	147	10.1	36400	160
4.68	16900	74.2	4.68	16900	74.2	6.19	22300	98.2	9.61	34600	152	9.61	34600	152	10.7	38400	169
4.82	17300	76.4	4.82	17300	76.4	6.37	22900	101	9.93	35700	157	9.93	35700	157	11.2	40200	177
4.94	17800	78.4	4.94	17800	78.4	6.54	23600	104	10.2	36800	162	10.2	36800	162	11.7	42100	185
5.06	18200	80.2	5.06	18200	80.2	6.71	24100	106	10.5	37800	167	10.5	37800	167	12.2	43800	193
5.17	18600	82.0	5.17	18600	82.0	6.86	24700	109	10.8	38800	171	10.8	38800	171	12.6	45500	200
5.28	19000	83.7	5.28	19000	83.7	7.00	25200	111	11.0	39700	175	11.0	39700	175	13.1	47100	207
5.38	19400	85.2	5.38	19400	85.2	7.14	25700	113	11.3	40500	178	11.3	40500	178	13.5	48700	214
5.47	19700	86.6	5.47	19700	86.6	7.28	26200	115	11.5	41300	182	11.5	41300	182	13.9	50200	221
5.55	20000	88.0	5.55	20000	88.0	7.40	26600	117	11.7	42000	185	11.7	42000	185	14.3	51600	227
5.63	20300	89.2	5.63	20300	89.2	7.52	27100	119	11.9	42700	188	11.9	42700	188	14.7	53000	233
5.70	20500	90.4	5.70	20500	90.4	7.63	27500	121	12.0	43400	191	12.0	43400	191	15.1	54300	239
5.77	20800	91.5	5.77	20800	91.5	7.74	27900	123	12.2	43900	194	12.2	43900	194	15.4	55600	245
5.84	21000	92.5	5.84	21000	92.5	7.84	28200	124	12.4	44500	196	12.4	44500	196	15.8	56800	250
5.90	21200	93.5	5.90	21200	93.5	7.94	28600	126	12.5	45000	198	12.5	45000	198	16.1	58000	255
5.96	21400	94.4	5.96	21400	94.4	8.03	28900	127	12.6	45500	200	12.6	45500	200	16.4	59100	260
6.01	21600	95.2	6.01	21600	95.2	8.12	29200	129	12.7	45900	202	12.7	45900	202	16.7	60200	265
6.06	21800	96.0	6.06	21800	96.0	8.20	29500	130	12.9	46300	204	12.9	46300	204	17.0	61200	269
6.10	22000	96.8	6.10	22000	96.8	8.28	29800	131	13.0	46700	205	13.0	46700	205	17.3	62100	274
6.15	22100	97.5	6.15	22100	97.5	8.36	30100	133	13.1	47000	207	13.1	47000	207	17.5	63000	278
6.19	22300	98.2	6.19	22300	98.2	8.44	30400	134	13.1	47300	208	13.1	47300	208	17.8	63900	281
6.23	22400	98.8	6.23	22400	98.8	8.51	30600	135	13.2	47600	209	13.2	47600	209	18.0	64700	285
6.27	22600	99.4	6.27	22600	99.4	8.58	30900	136	13.3	47800	210	13.3	47800	210	18.2	65500	288
6.31	22700	101	6.31	22700	101	8.65	31100	137	13.4	48100	212	13.4	48100	212	18.4	66200	292
6.35	22900	101	6.35	22900	101	8.72	31400	138	13.4	48300	213	13.4	48300	213	18.6	66900	295
6.39	23000	101	6.39	23000	101	8.78	31600	139	13.5	48500	214	13.5	48500	214	18.8	67600	297
6.42	23100	102	6.42	23100	102	8.85	31900	140	13.5	48700	214	13.5	48700	214	18.9	68200	300
6.46	23300	102	6.46	23300	102	8.91	32100	141	13.6	48800	215	13.6	48800	215	19.1	68700	303
6.50	23400	103	6.50	23400	103	8.98	32300	142	13.6	49000	216	13.6	49000	216	19.2	69200	305
6.54	23500	104	6.54	23500	104	9.04	32600	143	13.7	49200	217	13.7	49200	217	19.4	69700	307
6.58	23700	104	6.58	23700	104	9.11	32800	144	13.7	49300	217	13.7	49300	217	19.5	70200	309
6.62	23800	105	6.62	23800	105	9.18	33000	145	13.7	49500	218	13.7	49500	218	19.6	70600	311
6.67	24000	106	6.67	24000	106	9.25	33300	147	13.8	49600	218	13.8	49600	218	19.7	70900	312
6.72	24200	106	6.72	24200	106	9.32	33500	148	13.8	49800	219	13.8	49800	219	19.8	71300	314
6.77	24400	107	6.77	24400	107	9.39	33800	149	13.9	49900	220	13.9	49900	220	19.9	71600	315

DN50			DN65			DN80LF			DN80HF			DN100LF			DN100HF		
l/sec	l/hr	GPM	l/sec	l/hr	GPM	l/sec	l/hr	GPM	l/sec	l/hr	GPM	l/sec	l/hr	GPM	l/sec	l/hr	GPM
6.82	24600	108	6.82	24600	108	9.46	34100	150	13.9	50100	220	13.9	50100	220	20.0	71900	316
6.88	24800	109	6.88	24800	109	9.54	34300	151	14.0	50200	221	14.0	50200	221	20.0	72100	317
6.94	25000	110	6.94	25000	110	9.62	34600	153	14.0	50400	222	14.0	50400	222	20.1	72300	318

Flow Setting Chart for DN125-DN250 PICVs

Table 4. Flow Setting Chart for DN125-250

DN125LF			DN125HF			DN150LF			DN150HF-DN250								
l/sec	l/hr	GPM	l/sec	l/hr	GPM	l/sec	l/hr	GPM	l/sec	l/hr	GPM	l/sec	l/hr	GPM	l/sec	l/hr	GPM
6.48	23300	103	7.10	25600	113	7.10	25600	113	9.21	33100	146	57.5	207000	911			
7.24	26100	115	8.06	29000	128	8.06	29000	128	9.69	34900	154	58.3	210000	924			
7.98	28700	126	8.98	32300	142	8.98	32300	142	10.2	36800	162	59.1	213000	936			
8.70	31300	138	9.87	35500	157	9.87	35500	157	10.8	38900	171	59.8	215000	948			
9.39	33800	149	10.7	38600	170	10.7	38600	170	11.5	41200	182	60.6	218000	960			
10.1	36200	160	11.6	41600	183	11.6	41600	183	12.1	43700	192	61.3	221000	972			
10.7	38600	170	12.4	44500	196	12.4	44500	196	12.9	46300	204	62.0	223000	983			
11.4	40900	180	13.1	47300	208	13.1	47300	208	13.6	49100	216	62.7	226000	994			
12.0	43100	190	13.9	50000	220	13.9	50000	220	14.5	52000	229	63.4	228000	1000			
12.6	45200	199	14.6	52600	232	14.6	52600	232	15.3	55100	242	64.0	230000	1010			
13.1	47300	208	15.3	55100	243	15.3	55100	243	16.2	58200	256	64.6	233000	1020			
13.7	49300	217	16.0	57500	253	16.0	57500	253	17.1	61500	271	65.2	235000	1030			
14.2	51200	226	16.6	59800	264	16.6	59800	264	18.0	64900	286	65.8	237000	1040			
14.8	53100	234	17.2	62100	273	17.2	62100	273	19.0	68400	301	66.4	239000	1050			
15.3	54900	242	17.8	64200	283	17.8	64200	283	20.0	71900	317	66.9	241000	1060			
15.7	56600	249	18.4	66300	292	18.4	66300	292	21.0	75600	333	67.4	243000	1070			
16.2	58300	257	19.0	68300	301	19.0	68300	301	22.0	79300	349	68.0	245000	1080			
16.6	59900	264	19.5	70200	309	19.5	70200	309	23.1	83100	366	68.4	246000	1080			
17.1	61500	271	20.0	72100	317	20.0	72100	317	24.1	86900	383	68.9	248000	1090			
17.5	63000	277	20.5	73800	325	20.5	73800	325	25.2	90800	400	69.4	250000	1100			
17.9	64400	284	21.0	75500	333	21.0	75500	333	26.3	94700	417	69.8	251000	1110			
18.3	65800	290	21.4	77200	340	21.4	77200	340	27.4	98700	435	70.2	253000	1110			
18.6	67100	295	21.9	78700	347	21.9	78700	347	28.5	103000	452	70.6	254000	1120			
19.0	68300	301	22.3	80200	353	22.3	80200	353	29.6	107000	470	71.0	256000	1130			
19.3	69500	306	22.7	81700	360	22.7	81700	360	30.8	111000	488	71.4	257000	1130			
19.6	70700	311	23.1	83100	366	23.1	83100	366	31.9	115000	506	71.8	258000	1140			
19.9	71700	316	23.4	84400	372	23.4	84400	372	33.0	119000	523	72.1	260000	1140			
20.2	72800	320	23.8	85700	377	23.8	85700	377	34.2	123000	541	72.5	261000	1150			
20.5	73800	325	24.1	86900	383	24.1	86900	383	35.3	127000	559	72.8	262000	1150			
20.7	74700	329	24.5	88100	388	24.5	88100	388	36.4	131000	577	73.2	263000	1160			
21.0	75600	333	24.8	89200	393	24.8	89200	393	37.5	135000	595	73.5	265000	1170			
21.2	76400	336	25.1	90300	398	25.1	90300	398	38.6	139000	613	73.8	266000	1170			
21.4	77200	340	25.4	91400	402	25.4	91400	402	39.8	143000	630	74.2	267000	1180			
21.6	77900	343	25.7	92400	407	25.7	92400	407	40.9	147000	648	74.5	268000	1180			
21.8	78600	346	25.9	93400	411	25.9	93400	411	41.9	151000	665	74.8	269000	1190			
22.0	79200	349	26.2	94300	415	26.2	94300	415	43.0	155000	682	75.1	270000	1190			
22.2	79800	351	26.5	95200	419	26.5	95200	419	44.1	159000	699	75.5	272000	1200			

Control Curve of Flow

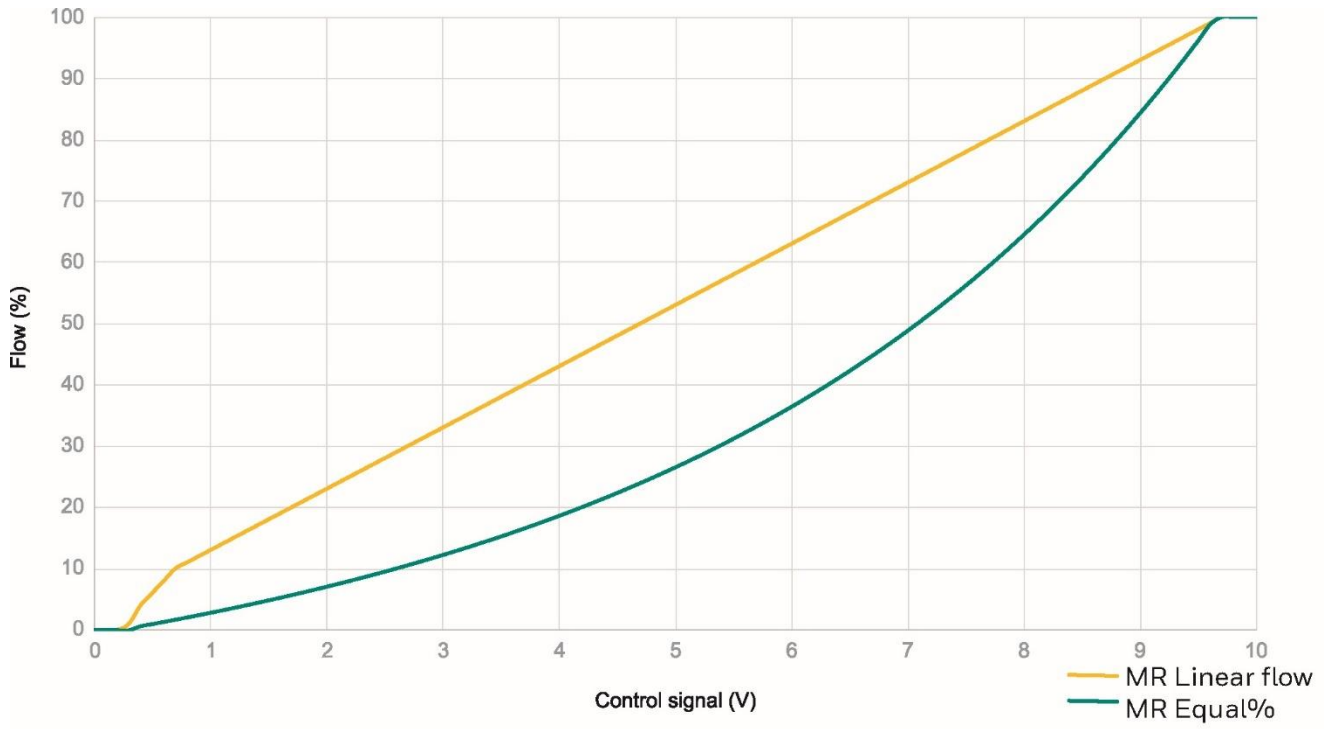

Figure 11. Control curve of flow from MR series actuators

Installation of Actuators compatible with DN 15-50

IMPORTANT: Do not connect power to the actuator unless the actuator is already fitted on the valve and NEVER install the actuator in a closed position this may damage the valve.

IMPORTANT: The actuator is supplied in an open position to ensure the easy commissioning of the system.

Procedure to install the Actuator

The procedure to install the actuator is as follow:

1. Install the valve body.
2. Mount the actuator on the valve as per the directions shown below.

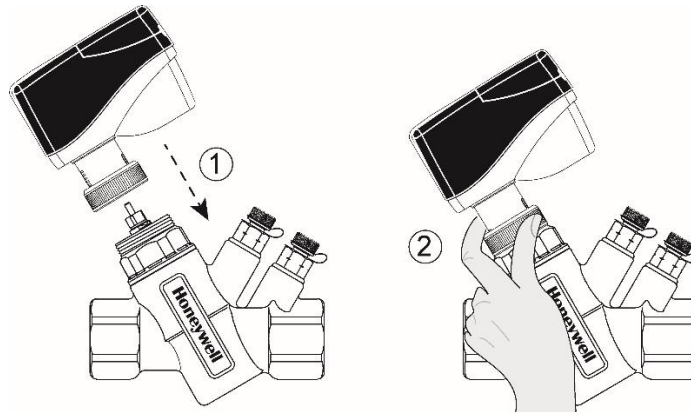

Figure 12. Assembly direction of an actuator on valve (example)

3. Tighten the connection union as shown below. Do not use additional tools as it may damage the actuator.

Mounting Position

The actuators can be mounted in any position (IP54 is dependent upon orientation; see *Figure 13*). Choose a mounting position permitting easy access to cables and controls. To guarantee IP54, upside-down installation is only recommended.

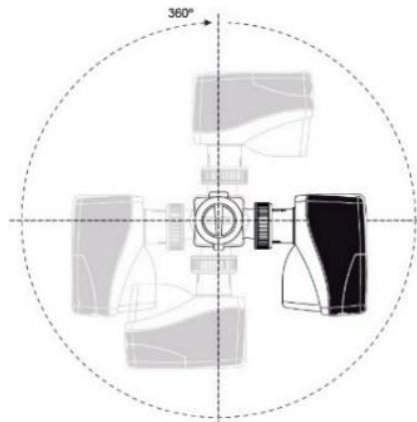

Figure 13. Actuator mounting for IP54

Procedure to remove the Actuator

1. Electrically open the actuator by activating DIP switch #6 for easier removal.
2. Hereafter finger loosen the connection union. Do not use additional tools as it may damage the actuator.

IMPORTANT: Please make sure that the actuator is electrically opened, before re-fitting it on the valve.

Installation of Thermoelectric Actuators (MLP41TNA and MLP71TNA)

IMPORTANT: Do not connect power to the actuator unless the actuator is already fitted on the valve and NEVER install the actuator in a closed position this may damage the valve.

IMPORTANT: The actuator is supplied in an open position to ensure the easy commissioning of the system.

Procedure to install the Actuator

The procedure to install the actuator is as follow:

1. Install the valve body.
2. The MLP41TNA and MLP71TNA (Thermoelectric) actuators are supplied with a separate black adaptor ring.
3. Mount the adaptor ring on top of the valve and finger tighten. Do not use additional tools. The MLP71TNA comes with plug-in cable. Make sure that the cable is properly fitted next.
4. The actuator can now be fitted on the adaptor ring. A click noise will indicate that the actuator is correctly fitted as shown below.

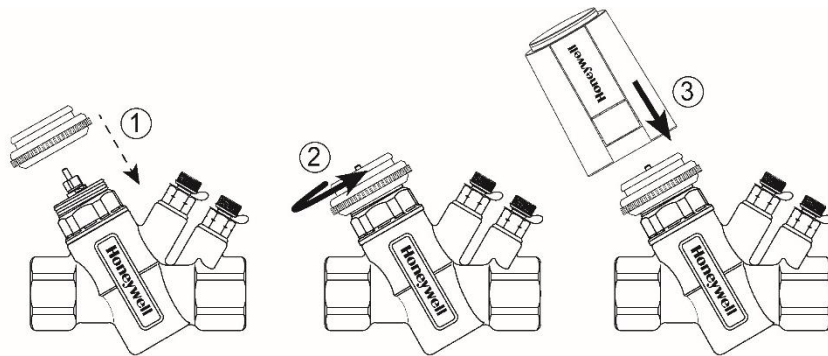

Figure 14. Installation of thermoelectric actuator on valve (example)

Mounting Position

The actuators can be mounted in any position (IP54 is dependent upon orientation; see *Figure 15*). Choose a mounting position permitting easy access to cables and controls. To guarantee IP54, upside-down installation is only recommended.

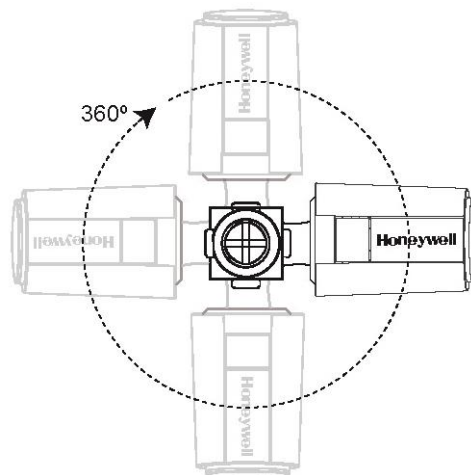

Figure 15. Actuator mounting for IP54

Procedure to remove the Actuator

1. Activate the release mechanism. Push the front button and removed the actuator from the adaptor ring.
2. Hereafter finger loosen the connection union. Do not use additional tools as it may damage the actuator.

IMPORTANT: Please make sure that the actuator is electrically opened, before re-fitting it on the valve.

Installation of Actuators compatible with DN50 – 250

Procedure to install the Actuator

The procedure to install the valve is as follows:

1. Grease the O-ring on the spindle adaptor with silicone grease before placing the spindle adaptor on the valve spindle.
2. Then place the actuator on the spindle adaptor and place the three actuators “legs” into the three holes in the mounting bracket as shown below. Make sure that the snap ring is clicked onto the mounting bracket, so that the snap ring is locked at the top of the mounting bracket, but still able to rotate.
3. Then finger turns the snap ring counterclockwise (upside view) approximately 1/6 of a turn until its stop points touch the actuator “legs” and the mounting is a lock with a (small) click. Do not use additional tools.

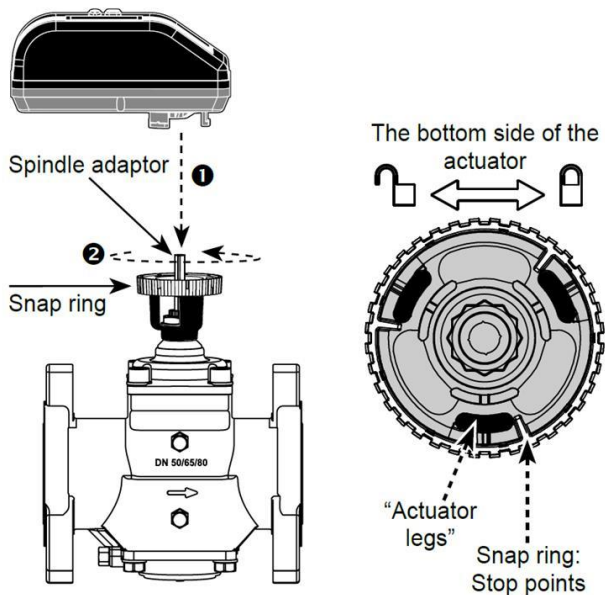

Figure 16 Actuator Assembly for DN 50-250

Mounting Position

The actuators can be mounted in any position (IP54 is dependent upon orientation; see Figure 17). Choose a mounting position permitting easy access to cables.

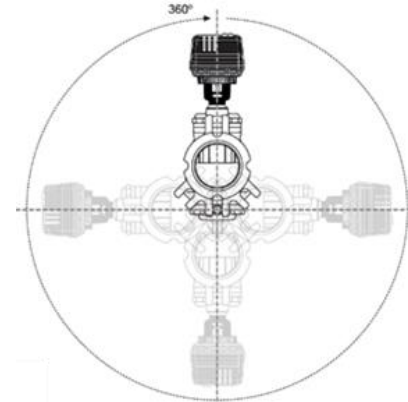

Figure 17. Actuator mounting for IP54

Procedure to remove the Actuator

The Steps to remove the actuator is as follows:

1. Make sure if the valve is in open position for easy removal of the actuator.
2. Turn the Snap ring in the clockwise direction until the actuator is loosened.
3. Lift the actuator up, to remove the actuator.

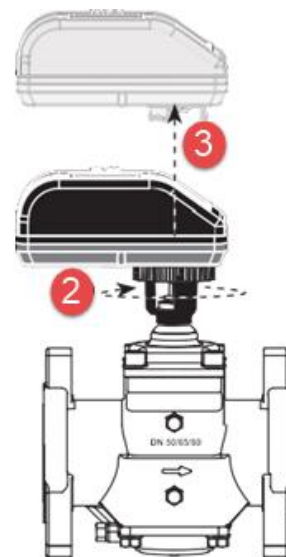

Figure 18 Actuator De-Assembling

IMPORTANT: Do not remove cover from actuator. Opening cover will void warranty.

ELECTRICAL INSTALLATIONS

Electrical Wiring for Actuators Compatible to DN15-50

The most important part of the electrical installation is the appropriate wiring set-up as per application. Below are examples of electrical wiring provided as per the actuator model.

MLP71MAA Actuators

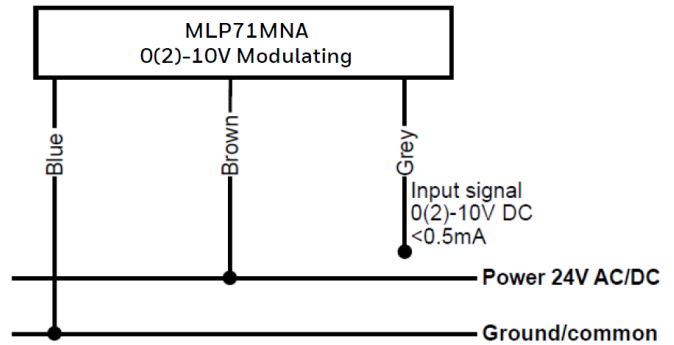
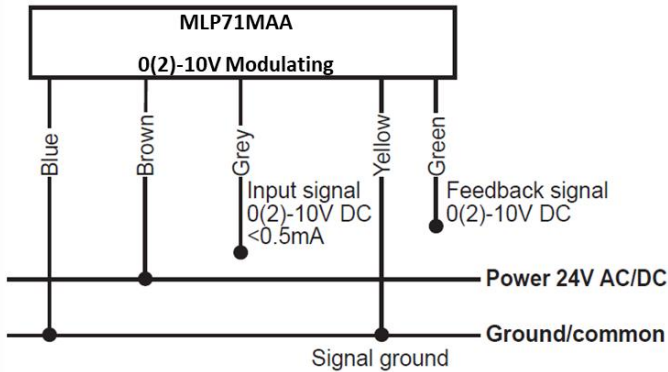

MLP41MNA Actuators

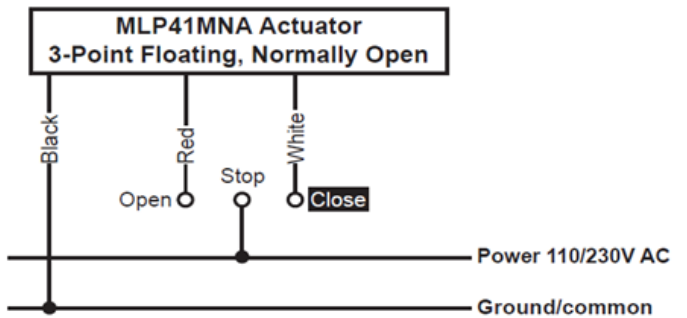
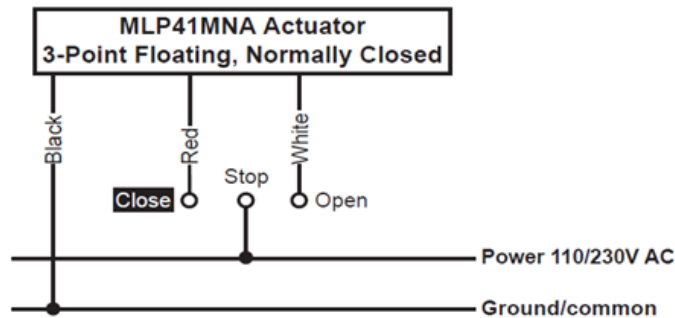
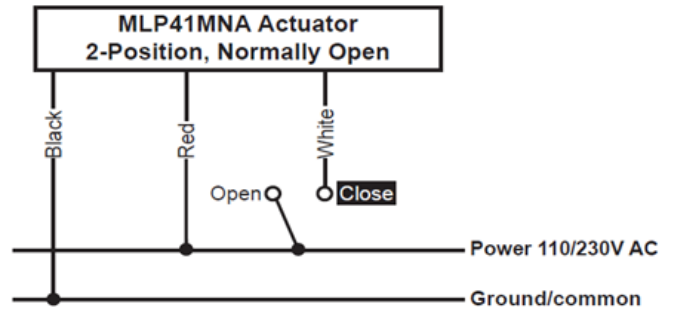
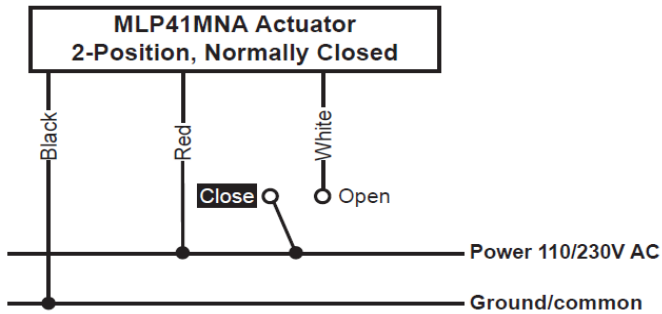

MLP41MNA-NU Actuators

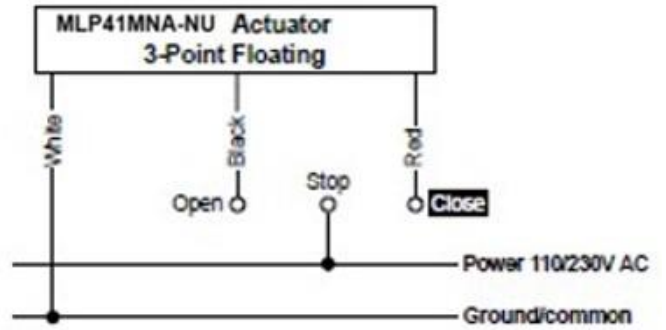
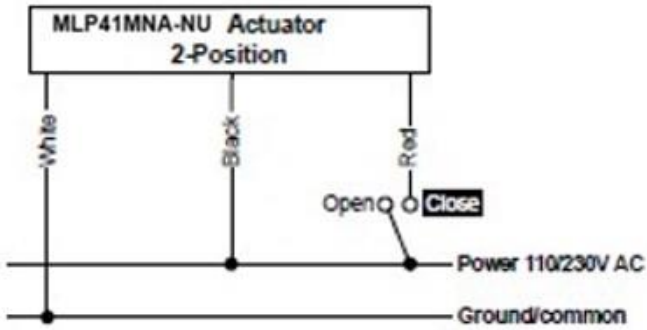

MLP71MNA-NU Actuators

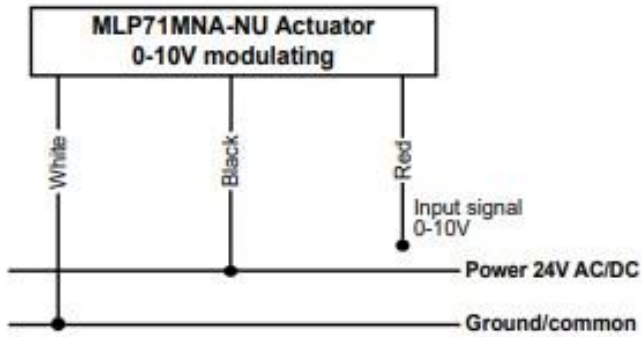

MLE-71MAA Actuators

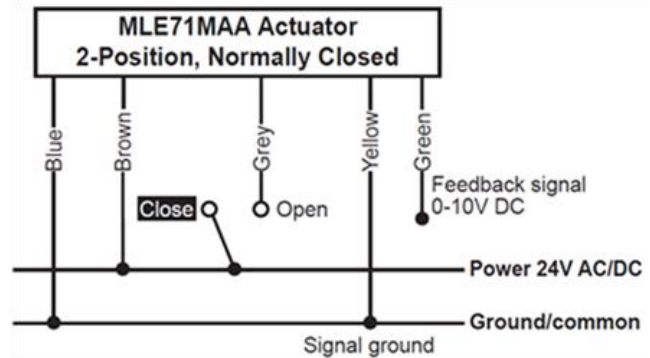
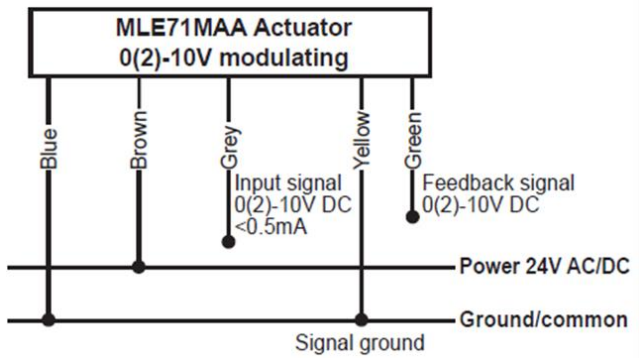

Start Up Sequence

When power to the actuator is turned On, the actuator will automatically calibrate to determine the closing point. Hereafter it will proceed to the normal operation mode (according to control signal).

For the failsafe version, capacitor charging will be prioritized (max. 120 sec depending on capacitor energy level) during start-up and repowering. After completion of the charging mode followed by calibration mode, the actuator will proceed to the normal operation mode.

Auto Cycle Sequence

Auto Cycle can be activated during commissioning. It prevents the valve from jamming when the valve is not moved for a longer period of inactivity. By moving DIP switch #1 from OFF to ON, Auto-Cycle is activated. The actuator will then perform a 50% stroke cycle every 3 weeks if no stroke movement has occurred.

Electrical Override

By moving DIP switch #6 from OFF to ON, electrical override is activated, and the actuator will open the valve fully. During an electrical override, the LED indicator will blink red and green. When DIP switch #6 is moved back to OFF, the actuator will re-calibrate and thereafter go into normal operation mode. Electrical override is performed with power supply.

Failsafe Mode

When power is lost, the actuator will go into failsafe mode after a few seconds, mandatory that capacitor charging, and start-up sequence are completed. The actuator will perform failsafe action (open or close) and stay in failsafe final position until the return of power. Upon power, the actuator remains in the final failsafe position until charging mode is reached (max. 60 sec). Hereafter the actuator will return to the normal operation mode.

MLP75MAB and MLE75MAB Actuators

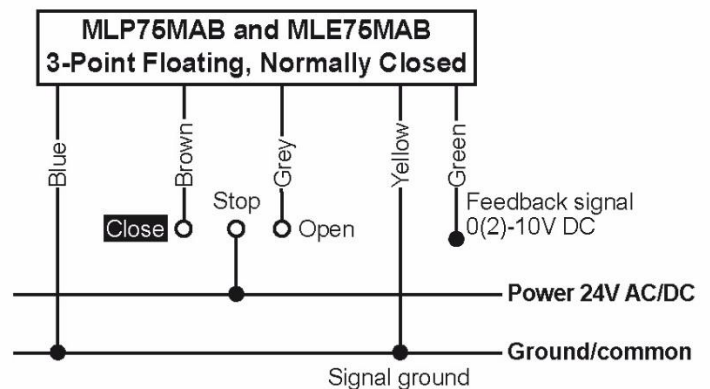
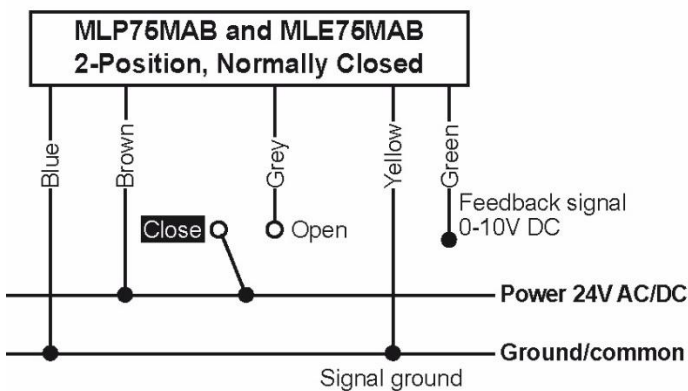
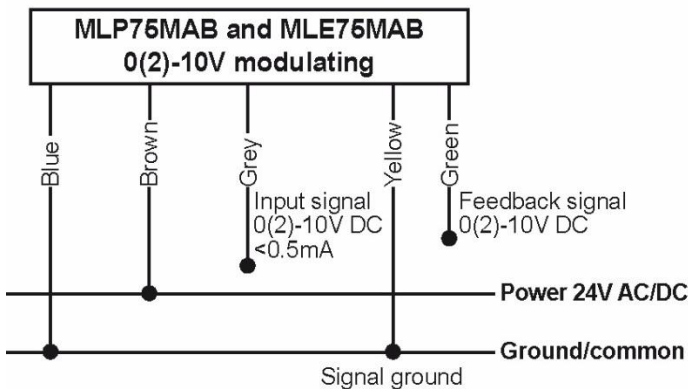

Configuration and Setup

Start Up Sequence

When power to the actuator is turned on, the actuator will automatically calibrate to determine closing point. Hereafter it will proceed to normal operation mode (according to control signal). For the failsafe version, capacitor charging will be prioritized (max. 215 sec depending on capacitor energy level) during start-up and re-powering. After completion of charging mode followed by calibration mode, the actuator will proceed to normal operation mode.

Auto Cycle Sequence

Auto Cycle can be activated during commissioning. It prevents the valve from jamming when the valve is not moved for a longer period of inactivity. By moving DIP switch #1 from OFF to ON, Auto Cycle is activated. Actuator will then perform 50% stroke cycle every 3 weeks if no stroke movement has occurred.

Re-Calibration (MLP75MAB)

By flipping DIP switch #6 from one setting to the other (starting position indifferent) re-calibration is activated. After completed re-calibration the actuator will automatically go into normal operation. During re-calibration mode the LED will blink green.

Manual Override (MLP75MAB)

Before performing manual override, please turn off the power supply. Lift the silicone cap on the top of the actuator to get access to manual override. Manual override is performed by a 4 mm (~5/32") hex key. Clockwise turning will open the valve and counterclockwise turning will close the valve.

Electrical Override (MLE75MAB)

By moving DIP switch #6 from OFF to ON, electrical override is activated, and the actuator will open valve fully. During electrical override the LED indicator will blink red and green. When DIP switch #6 is moved back to OFF, the actuator will re-calibrate and thereafter go into normal operation mode. Electrical override is performed with power supply on.

Failsafe Mode (MLE75MAB)

When power is lost, the actuator will go into failsafe mode after a few seconds, mandatory that capacitor charging, and start-up sequence are completed. The actuator will perform failsafe action (open or close) and stay in failsafe final position until return of power. Upon power, the actuator remains in the final failsafe position until charging mode is reached (max. 15 sec). Hereafter the actuator will return to normal operation mode.

MLP41TNA and MLP71TNA (Thermoelectric) Actuators

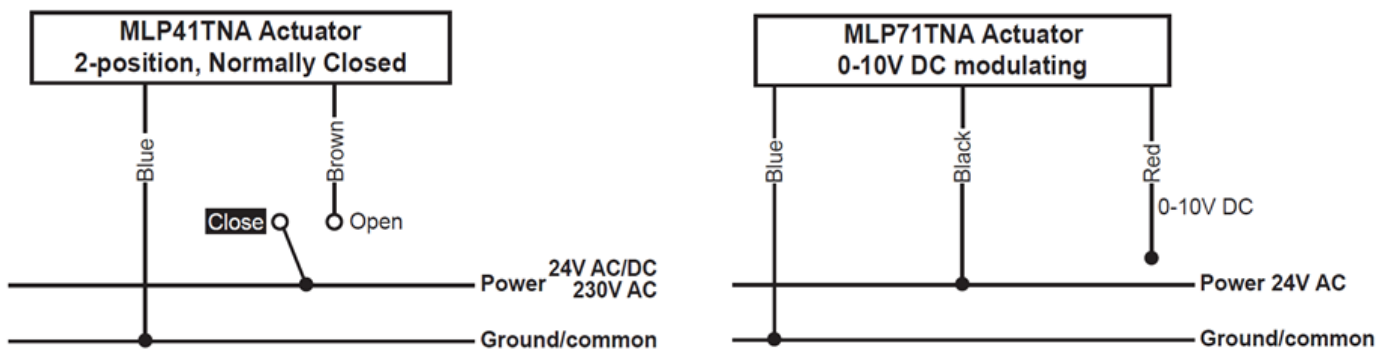

24V versions must be powered by a safety isolating transformer (for AC variant) according to EN 61558-2-6 or class II FCC-quality proofed or a switching power supply (for DC variant) according to EN 61558-2-16. For MLP71TNA actuator the power supply must have a maximum power output of 100VA.

Start-up Sequence

During FIRST TIME POWERING operating voltage must be applied for at least 6 minutes. Ensure to have the actuator mounted on the valve, when powering as it has automatic stroke detection. To speed up a re-calibration of the stroke, close (0V) the actuator for 30 minutes then open (10V) for 30 minutes and leave the power on for the next 24 hours.

DIP Switch Settings

The valve functions are set on DIP switches found under the connection cover. PCB mounted electrical components will not be directly exposed when DIP switches are to be set. The factory setting for all switches is OFF. The DIP switches are available only in MLP71MAA, MLE71MAA, MLP75MAB, and MLE75MAB.

For Fail-safe actuators (MLE71MAA and MLE75MAB)

Switch number	Switch Function		
	On	Off	Factory Settings
Switch #6	Electrical override ON	Electrical override OFF	Off
Switch #5	Failsafe open	Failsafe close	Normally Closed
Switch #4	Equal % control	Linear control	Linear control.
Switch #3	Normally open	Normally close	Normally closed; 0V DC = valve closed.
Switch #2	Analog 2-10V DC	Analog 0-10V DC	0-10V DC
Switch #1	Autocycle ON	Autocycle OFF	OFF

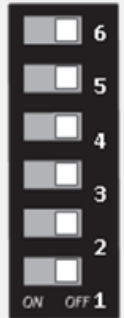

For non - Fail-safe actuators (MLE71MAA and MLE75MAB)

Switch number	Switch Function		
	On	Off	Factory Settings
Switch #6	Electrical override ON	Electrical override OFF	Off
Switch #5	- (No function)		Normally Closed
Switch #4	Equal % control	Linear control	Linear control.
Switch #3	Normally open	Normally close	Normally closed; 0V DC = valve closed.
Switch #2	Analog 2-10V DC	Analog 0-10V DC	0-10V DC
Switch #1	Autocycle ON	Autocycle OFF	OFF

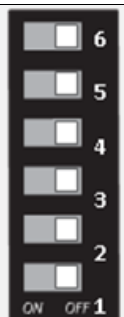

LED Status

The LED indicator is visible through the dark colored transparent connection cover. The LED indication will give the following statuses.

Switch number	Switch Function			
	MLP75MAB	MLE75MAB	MLP71MAA	MLE71MAA
Normal operation mode	Full on green	Full on green	Full on green	Full on green
Charging mode	n/a	Blinking red (200 sec)	n/a	Blinking red (60 sec)
Calibration mode (closing point adjustment)	Blinking green	Blinking green	Blinking green	Blinking green
Electrical override mode	n/a	Blinking red/green	Blinking red/green	Blinking red/green
Failsafe mode	n/a	OFF	n/a	OFF
Normal operation mode	Full on green	Full on green	--	--

Electrical Wiring for Actuators Compatible to DN50-250

MRP75MAC / MRE75MAC

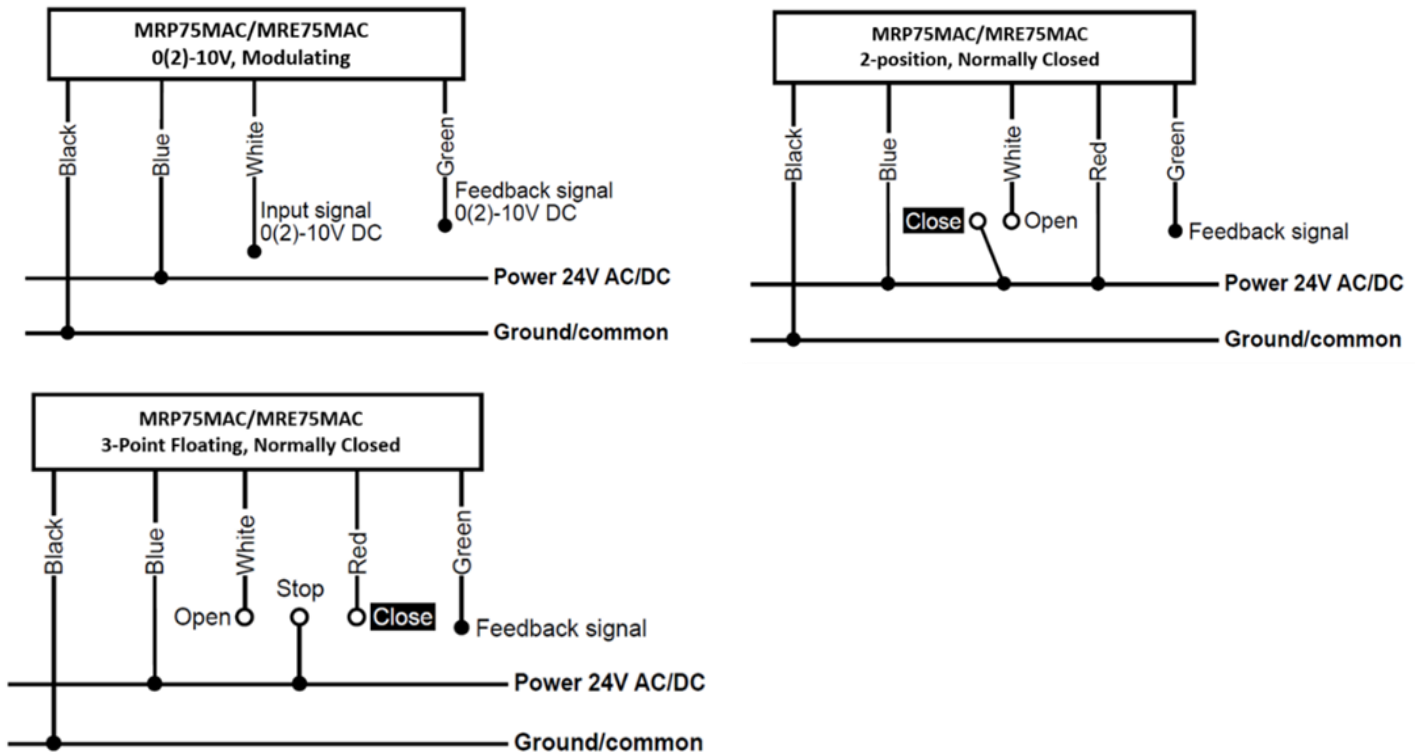

Table 5. List of Reference Valve Codes

Honeywell Part codes	Reference Valve Codes*
VPI050FPH4	50H
VPI065FPH4	65H
VPI080FPL4	80L
VPI080FPH4	80H
VPI100FPL4	100L
VPI100FPH4	100H
VPI125FPL4	125L
VPI125FPH4	125H
VPI150FPL4	150L
VPI150FPH4	150H
VPI200FPH4	200H
VPI250FPH4	250H

*While setting up the reference code on the valve, please select the reference code on the actuator to get the maximum flow settings.

Configuration and Setup

Start-Up Sequence

When power is turned on, the actuator will automatically calibrate to determine the closing point of the valve. Calibration can take up to 10 minutes depending on the valve’s position at start-up. During the calibration actuator, the display will show “CAL”. Hereafter it will proceed to the normal operation mode (according to control signal).

If no control signal is detected, flush is started if enabled in the programming menu (enabled by default), opening the valve to 5/6 of fully open. Actuator display will show “FLUSH” until control signal is detected.

At first start-up please enter programming menu to set actuator settings.

Programming Menu



Figure 19. Typical display of MR series actuators

The programming menu is always accessible. To enter the programming menu, simultaneously press ⇐ and ⇒ for 6 seconds, until the bottom line in display blinks.









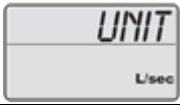

To change a value, press △, or ▽. For quick scroll through values hold down △ or ▽. Press ⇒ to accept a value and go to the next step and press ⇐ to go to the previous step.

For fast menu exit press ⇐ and ⇒ simultaneously for 6 seconds. The actuator will automatically return to normal operation mode if no action is detected on arrow keys for 1 minute.

NOTE- All values selected in the programming menu are stored in non-volatile memory

Table 6. List of Programming menus

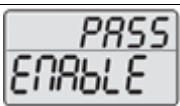
Step	Display	Description	Valve
0		Password. *scrolling top: ENTER PASSWORD	Disabled by default Password: 3569266. Only if Enabled (in step 12). Change one digit at a time, press ⇒ and ⇐ to move between digits. At last digit, press ⇒ to go to next step
1		Select language *scrolling top: SELECT LANGUAGE	Default: English.
2		Select valve model onto which the actuator is installed. *scrolling top: SELECT VALVE MODEL	Default: 50H. Select from the 12 available valve models. Options: 50H, 65H, 80L ... See, <i>Table 5. List of Reference Valve Codes</i> for more options.

Step	Display	Description	Valve
3		Choose unit scale for flow rate. *scrolling top: SELECT UNIT SCALE	Default: l/sec. Options: l/sec or l/hr or GPM
4		Activate Flush mode at start-up *scrolling top: SELECT FLUSH MODE	Default: Enable. Options: Enable or Disable. When no control signal (analog) is detected at start up, flush mode is started (5/6 of fully opened). It will be dismissed when control signal is detected.
5		Select type of control signal *scrolling top: SELECT CONTROL SIGNAL	Default: 2-10VDC. Options: 2-10VDC or 4-20mA or digital. Choose: <ul style="list-style-type: none"> • 2-10VDC for VDC • 4-20mA for mA • Digital for 2 position or 3-point floating.
6		Select minimum control value *scrolling top: SET MINIMUM LIMIT	Volt default: 2. Options: from 0-7. Increment: 0.1. mA default: 4. Options: from 0-14. Increment: 0.2. NA if Digital (in step 5).
7		Select maximum control value *scrolling top: SET MAXIMUM LIMIT	Volt default: 10. Options: from 3-10 and at least 3 VDC greater than the selected minimum limit. Increment: 0.1. mA default: 20. Options: from 6-20 and at least 6 mA greater than the selected minimum limit. Increment: 0.2. NA if Digital (in step 5).
8		select feedback signal *scrolling top: SELECT FEEDBACK SIGNAL	Default: AU; Automatic match of control signal if analog. Options: 0-10 VDC, 2-10 VDC or 4-20 mA or AU. If Digital (in step 5) AU is not an option.
9		Set the designed maximum flow. Accuracy: Greatest of either ±5% of de-signed max. flow or ±2% of max. valve flow. *scrolling top: SELECT MAXIMUM FLOW	Default: Maximum setting. Values depend on valve model and unit scale chosen in step 2 and 3. Stepping increments as per tech note
10		Select direction of rotation. *scrolling top: SELECT ROTAT DIRECT	Default: Normally Closed (NC). Options: Normally Open (NO) or Normally Closed (NC).
11		Select actuator mode. *scrolling top: ACTUATOR MODE	Default: Linear flow. Options: Linear flow, Equal percentage, Linear rotation or Linear signal.
12		Activation of password. *scrolling top: ACTIVAT PASSWORD	Default: Disable. Options: Enable or Disable. If Enabled password is required to access alarm and programming menu.
13		Select direction of rotation when Failsafe. *scrolling top: SELECT FAIL SAFE DIRECT	Default: Closed. Options: Open or Closed. Only valid for SM.0.0.0.4 (failsafe model). Failsafe direction open means opening to max. flow chosen in step 9.

In Operation for DN50 – DN250

During operating of MRP75MAC and MRE75MAC actuators, users will see below display screens which shows multiple symbols and information. Carefully go through below table to familiarize with display indications during operation with the meaning each symbol and operation.

Table 7. Display details during operation

Display	Description	Valve
	Indicates unit scale system	l/sec or l/min or GPM. mA or VDC.
	Indicates battery level.	Basic version with no battery (MRP75MAC) Failsafe version with battery (MRE75MAC). Battery level low, charging needed. Medium battery level. Battery charged.
	Alarm indicator.	Blinking if actuator is still functional (warning). Fully on if actuator is not working (critical).
<p>Current flow rate¹. Indicates current flow rate in l/sec, l/hr or GPM.</p>		CONTROL SIGNAL 2.0 VDC FEEDBACK SIGNAL 2.0 VDC VALVE 50H PRESSURE RANGE 30-800 kPaD MAXIMUM FLOW RATE 6.580 L/SEC OPERAT DIRECT NC ACTUAT.MODE LIN FLO FAIL SAFE DIRECT CLOSE ERROR CODE 01

Use ⇨ to go to next information line and ⇩ to go to the previous.



Table 8. List of information from upper part of display during operation

Information	Meaning	Options
Control signal	Indicates value of control signal.	0-10VDC or 0-20mA or Open/Stop/Close
Feedback signal	Indicates value of feedback signal.	0-10 VDC or 0-20 mA
Valve	Indicates valve model.	50H, 65H, 80L ... See, <i>Table 5. List of Reference Valve Codes</i> for more options.
Pressure range	Indicates pressure range.	32-320 kPaD, 40-320 kPaD ...
Maximum flow rate	Indicates selected maximum designed flow rate.	Depends on valve etc. l/sec, l/hr or GPM
Operational direction	Indicates direction of rotation.	NO or NC
Actuator mode	Indicates control mode	Linear flow, Equal percentage, Linear rotation or Linear Signal.
Failsafe direction	Indicates failsafe direction.	Open or Closed Valid for failsafe actuator models
Critical Alarm	Indicates alarm error code.	01, 03, 05 (without failsafe) or 06. Only if critical alarm is present.

NOTE 1: The flow rate shown on the actuator display is a calculated value. Flow rates below 1.0 valve rotation is shown as indications, illustrated with an apostrophe in front of the flow rate. If display shows “NA” the valve model has not been chosen in programming menu step 2.

Alarm Menu

To enter the alarm menu, simultaneously press Δ and ∇ for 6 seconds. The alarm menu is only accessible if an alarm is present (i.e. when the icon  is displayed). Press \rightarrow to go to the next alarm display and press \leftarrow to go to previous. For fast menu exit press Δ and ∇ simultaneously for 6 seconds. The actuator will automatically return to normal operation mode if no action is detected on arrow keys for 1 minute.

If the actuator is still functioning (= warning code 01, 04, 05 with failsafe and 07 with failsafe), the  icon will blink. If the actuator is NOT functioning (=error code 01, 03, 05, 06 with failsafe and 08), the  icon is fully on. Error codes will be shown in the information part of the actuator display.













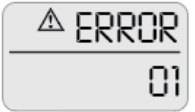

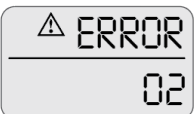

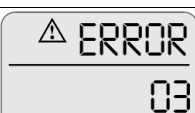
Display	Description	Action
	Alarm.	
	Enter password.	If enabled in programming menu step 11 Disabled by default. Password: 3569266.

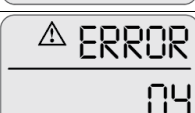
Table 9. List of Error display with details

Code	Display	Icon	Description	Details
01		 FULL ON	Valve/actuator is over-torqued.	Operation is stopped. Actuator will retry operation every.
02		 BLINKING	Actuator has reached its torque limit in the past	Actuator is functioning. To reset the alarm simultaneously press Δ and \leftarrow for 6 seconds.
03		 FULL ON	Critical – over temperature.	Critical: Temperature in actuator is at least 70°C, motor operation is stopped. If temperature is decreasing operation will resume.
04		 BLINKING	High temperature.	Actuator is still functioning. Temperature in actuator is at least 50°C as limited according to tech note. If temperature is decreasing, operation will resume.
05		 FULL ON	No Failsafe: Power supply not in range	Operation is stopped. Alarm will automatically reset when voltage is back in range.
		 BLINKING	With Failsafe: Power supply not detected / not in range.	Failsafe is activated. Alarm will automatically reset when voltage is back in range.
06		 FULL ON	Control signal not detected.	Operation is stopped. Alarm will automatically reset when control signal is back in range.
07		 BLINKING	Battery error.	Battery is not properly connected. Alarm will reset when battery is properly connected. Only valid for failsafe actuators.

Auto-stroke sequence for DN 50- 250

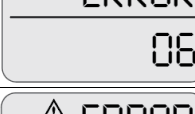
In case the valve does not operate as expected, start the auto-stroke sequence to re-calibrate the closing point making sure that the actuator is able to open the valve fully. Press ⇨ and △ simultaneously for 6 seconds to start auto-stroke. An auto-stroke sequence cannot be cancelled. During auto-stroke actuator display will show "AUTO STROKE CYCLES". Hereafter it will proceed to normal operation mode (according to control signal). If the actuator is not able to open valve fully, error code 01 will be displayed.

Manual Override

Manual override is used to temporarily set the valve position regardless the settings and control signal for the actuator. Disconnect power to the actuator and remove the actuator from the valve. Turn the valve spindle clockwise to close valve and counterclockwise to open. Re-mount the actuator and connect power. Be aware to protect that actuator from water while not on the valve.

NOTE: When manually operating the valve (actuator disconnected) do not use more than 10 Nm torque. Use of higher torque will void warranty.

Failsafe Mode for DN 50- 250

In case of power failure, failsafe models will move actuator to the position chosen in programming menu step 13 and show warning code 05 in the actuator display. When voltage is back in range ⚠ will be reset.

OPERATION & CHECKOUT

Once both the mechanical and electrical installations are complete:

1. Power On the system with precautionary measures and cycle the actuator to verify if it's working as per set parameters and as per intended application.
2. If the actuator output is incorrect, contact the Honeywell local representative.
3. If the control scheme requires fail-safe operation, ensure that, upon removal of power, the fail position coincides with the control sequence.

UNITED ARAB EMIRATES

Honeywell Building Technologies
Building Management Systems
Emaar Business Park, Sheikh Zayed Road,
Building No. 2, 2nd floor, 201
Post Office Box 232362,
Dubai, United Arab Emirates.
Call: +971 44541704

TURKEY

Honeywell Teknoloji A.Ş.
Cayir Cad. No:7 Kat:1
Icerenkoy 34752 Istanbul, Turkey.
Call: +90 216 578 71 10
Faks: +90 216 575 66 37

QATAR

Honeywell Technology Solutions
P.O. Box 63757, Doha, Qatar
Phone: +974 4 4066 200
Fax: +974 4 4066 711

INDIA

Honeywell HBT India Buildings
Unitech Trade Center, 5th Floor, Sector-43,
Block C, Sushant Lok Phase - I,
Gurgaon - 122 002, India.
Call: 1-800-103-0339
Email: HBTIndiabuildings@honeywell.com

ASEAN

Honeywell Building Technologies (ASEAN)
Honeywell International Sdn Bhd
Level 25, UOA Corp Tower, Lobby B
Avenue 10, The Vertical, Bangsar South City
59200, Kuala Lumpur, Malaysia.
Call: +60 3-2777 3100
Email: buildings.asean@honeywell.com

PACIFIC

Honeywell
2 Richardson Pl, North Ryde NSW 2113,
Australia.
Call: 1300 363 936
Email: pacificcustomercare@honeywell.com

KOREA

Honeywell HBT Buildings Technologies
5F SangAm IT Tower, 434 Worldcup buk-ro,
Mapo-gu, Seoul 03922, Korea.
Call: 0082-2-799-6271, 6009, 6158, 3535, 6361
Email: info.btkorea@Honeywell.com

By using this Honeywell literature, you agree that Honeywell will have no liability for any damages arising out of your use or modification to, the literature. You will defend and indemnify Honeywell, its affiliates and subsidiaries, from and against any liability, cost, or damages, including attorneys' fees, arising out of, or resulting from, any modification to the literature by you.

**VPI PRESSURE INDEPENDENT
CONTROL VALVES AND ACTUATORS**