

TC300 Thermostats

CONNECTED DEVICE FOR COMMERCIAL BUILDINGS

MOUNTING & INSTALLATION INSTRUCTIONS

INTRODUCTION

TC300 Thermostats are designed to be wall-mounted indoors. Mount in a clean, dry location away from windows, air ducts, and other places where environmental factors may affect temperature and humidity readings. If you mount the thermostat on the interior of an outside wall, thoroughly insulate it so the outside air behind the sensor does not affect the sensor reading.

To meet the requirements of the Americans with Disabilities Act, mount no higher than 48" from the floor and with a minimum clear floor space of 30" X 48" (760 X 1220 mm).

Supported Documents

- TC300 Commercial Thermostats Datasheet (31-00645)
- TC300 Commercial Thermostats User Guide (31-00644)
- TC300 Commercial Thermostats Pocket guide (31-00648)
- TC300 Deco Plate Pocket guide (31-00657)
- TC300 BACnet Integration guide (31-00646)
- TC300 Safety Sheet (31-00643)

When installing this product

1. Read these instructions carefully. Failure to follow them could damage the product or cause a hazardous condition.
2. Check the ratings given in the instructions and marked on the product to make sure the product is suitable for your application.
3. Installer must be a trained, experienced service technician.
4. After installation is complete, check the product operation.
5. Be sure wiring complies with all applicable codes, ordinances, and regulations.

WARNING

Electrical Shock Hazard.

Can cause severe injury, death or property damage.

Disconnect the power supply before beginning installation to prevent electrical shock and equipment damage. More than one power supply may have to be disconnected.



MERCURY NOTICE

If this control is replacing a control that contains mercury in a sealed tube, do not place your old control in the trash. Dispose of it properly. Contact your local waste management authority for instructions regarding recycling and the proper disposal of an old control. If you have questions, contact Honeywell Customer Care Center.

Location

Do not install the Thermostat unit where it can be affected by:

- drafts or dead spots behind doors and in corners.
- hot or cold air from ducts.
- radiant heat from sun or appliances.
- concealed pipes and chimneys.
- unheated (uncooled) areas such as an outside wall behind the thermostat.

IMPORTANT

To avoid electrical interference, which can cause erratic performances, keep wiring runs as short as possible and do not run thermostat wires adjacent to the line voltage electrical distribution systems. Use shielded cable. The cable shield must be grounded only at the controlled equipment case.

USING ONBOARD TEMPERATURE SENSOR

Install the Thermostat about 4 ft. (1.2 m) above the floor in an area with good air circulation at average temperature. (See Fig. 1). Confirm mounting height meets Americans with Disabilities Act requirements.

USING EXTERNAL TEMP./HUM. SENSORS

When using the remote-mounted temperature (and humidity) sensor(s) to sense ambient conditions, install the Thermostat in an area that is accessible for setting and adjusting the temperature and settings.

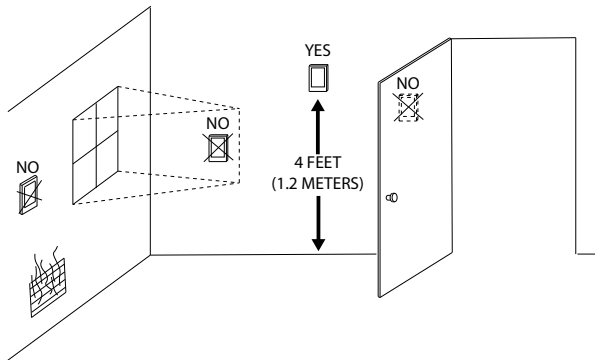

Fig. 1. Typical mounting location of the thermostat

WEEE



WEEE (Waste of Electrical and Electronic Equipment)

- At the end of the product life, dispose of the packaging and product in an appropriate recycling center.
- Do not dispose of the device with the usual domestic refuse.
- Do not burn the device.

This symbol on our product shows a crossed-out “wheellie-bin” as required by law regarding the Waste of Electrical and Electronic Equipment (WEEE) disposal. This indicates your responsibility to contribute to saving the environment by proper disposal of this Waste i.e. Do not dispose of this product with your other wastes. To know the right disposal mechanism please check the applicable law.

Regulation (EC) No 1907/2006

According to Article 33 of Reach Regulation be informed that the substances listed below may be contained in these products above the threshold level of 0.1% by weight of the listed article.

Product/Part Code	Substance Name	CAS Number
Only TC300 thermostats main board PCBA	Lead	7439-92-1
	Lead oxide	1317-36-8

Power supply guidelines and requirements

TCxB/TC32xB (24 VAC)

These thermostats use 24 VAC power from a UL Listed Class-2 24 VAC transformer (not provided in the kit). It also uses a half-wave rectifier to convert the AC power supply to

onboard power. This enables multiple devices with half-wave power supplies to be powered from a single, grounded transformer.

⚠ WARNING

Half wave devices and full wave devices must not use the same AC transformer.

You must maintain wiring polarity. Failure to do so can result in equipment damage. If the HVAC equipment has an internal circuit board that is powered by the same transformer that will power the Thermostat, verify that it is NOT full wave.

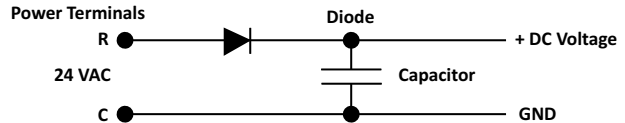

Fig. 2. Power terminals

IMPORTANT

Use an UL Class 2 rated Transformer or a lesser capable transformer.

The 24 VAC secondary leads are not interchangeable. Once a lead connects to the GND terminal, it is the grounded lead. Observe and maintain polarity for subsequent connections. The GND terminal provides a reference ground for the circuit board and communications wiring. Use 18 AWG cable for best results.

TC30xC / TC32xC (100-240VAC)

These thermostats use line-voltage power transmitted by a power line, such as a cable, circuit, or conducting wire. Use the proper overload protection.

Power supply wire sizing

Long power supply wiring runs require selecting the wire gauge appropriately. If the wire gauge is inadequate the increased resistance and associated voltage drop may result in insufficient voltage supply to the Thermostat. The recommended wire gauge guidelines are as follows.

Table 1. Power supply and wire sizing

SKU	Terminal	Wire Gauge	Load
TC300B-G	R, C	14-18 AWG	0-4 A
TC303B-G			
TC320B-G	DO	14-26 AWG	0-1 A
TC321B-G			
TC322B-G	Others	14-26 AWG	N/A
TC300C-G	L,N	14-18 AWG	0-10 A
TC320C-G			
TC300C-G1	DO3-DO5	14-20 AWG	0-3 A
TC303C-G			
TC320C-G1	DO1, DO2	14-26 AWG	0-1 A
TC321C-G			
TC322C-G	Others	14-26 AWG	N/A

NOTE: The recommended wire gauge 14-26 AWG (0.2-1.5 mm² for solid or stranded, max 2.5 mm² for solid).

DO1, DO2, DO3, DIO1, and DIO2 all relay outputs are powered from the external transformer. The minimum load includes Thermostat and analog outputs at full load (Max. 10 V voltage output for minimum 2000 ohm input impedance).

Every relay output is N.O. (Normally Open) contacts with a maximum switch rating of 24 VAC @1 A (24 VA). The allowed maximum load is 96 VA, which assumes all 5 relay output loads are powered from the transformer. Actual power requirements depend on connected loads.

TC30xC / TC32xC (100-240VAC)

Max. Load <= 10VA (Power Supply).

⚠ WARNING

Ensure that for the B models thermostat power connections only use R and C terminals. COM should only be used for analog inputs/outputs. Failure to follow these instructions may result in thermostat operational and communication failures or equipment damage.

Wiring the wallplate

All wiring must comply with local electrical codes and ordinances. Supports 14-26 AWG (0.2-1.5 mm² for solid or stranded, max 2.5 mm² for solid) wires. Follow equipment manufacturer wiring instructions when available. A letter code is located near each terminal for identification.

RS485 interface cable type

One or two pairs (depending on the application) of twisted pairs complying with EIA485 standard (level IV, 22 AWG, solid core, non-shielded). e.g., J-Y-Y 2*2*0.8 or shielded wire.

An MSTP EIA-485 network shall use shielded twisted pair cable with a characteristic impedance between 100 and 130 ohms. Distributed capacitance between conductors shall be less than 100 pF per meter (30 pF per foot). Distributed capacitance between conductors and shield shall be less than 200 pF per meter. A termination resistor of 120-130 ohms should be used at each end of the daisy chain as labelled R_T.

RS485 cabling arrangement

Shielded cable with twisted pair

NOTES:

- To 24V version: Connect "C" to Ground.
- To line voltage version: Connect "COM" to Ground.

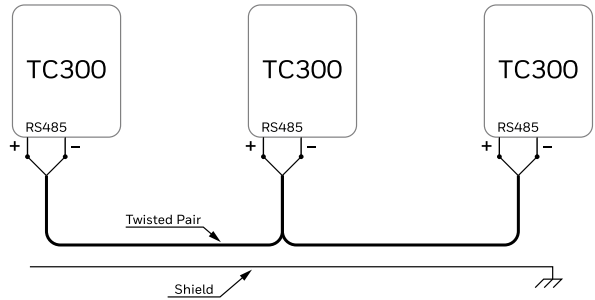
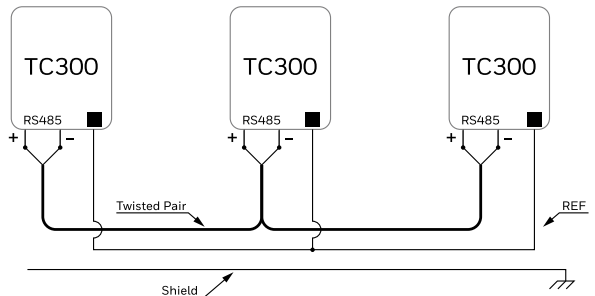

Fig. 3. RS485 Wiring

Shielded cable with twisted pair and reference

NOTES:

- To 24V version: Connect "C" to Reference.
- To line voltage version: Connect "COM" to Reference.



■ Terminal "C" for 24V
Terminal "COM" for line voltage

Fig. 4. RS485 Wiring

TC300 THERMOSTAT POWER WIRING

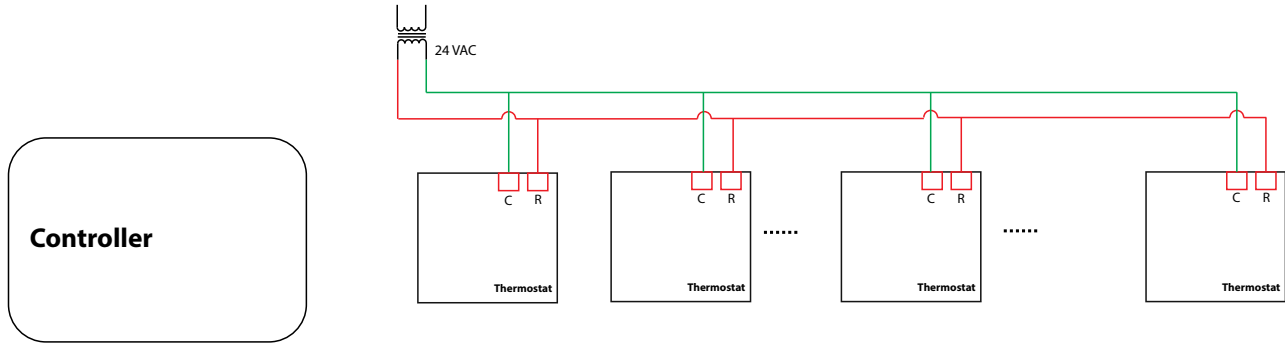

Fig. 5. TC300 thermostat power wiring

If the controller shares the power transformer with TC300 thermostats, the connection style depends on the power design of controller and please consult the technical support to avoid short circuit.

If TC300 thermostats are connected to a controller and share the transformer, please make sure the 24 VAC power wires are connected to the thermostats in the same sequence, as showed in the above figure. The green wire is connected to the C terminal and red wire is connected to the R terminal. Incorrect connection style can cause a short circuit.

Mounting wallplate on the drywall

Mount the wallplate vertically on the wall. It supports 14-26 AWG (0.2-1.5 mm² for solid or stranded, max 2.5 mm² for solid) wires.

NOTE: If you are using a TC300 Deco plate for thermostat mounting, refer to the Deco plate pocket guide (31-00657) also.

1. At the bottom of the thermostat, loosen the Security screw using a screwdriver by turning it counterclockwise direction.

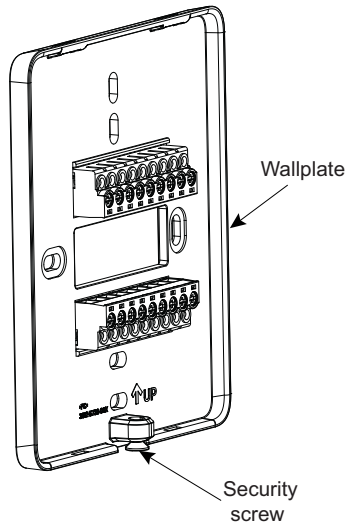
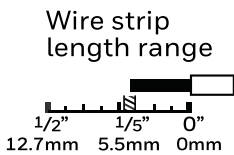
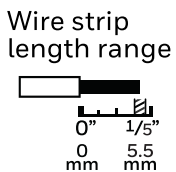

Fig. 6. Loosen the security screw

2. Before mounting the wallplate, make sure that the thermostat wires are stripped to the length marked on the wallplate.



For B Models



For C Models

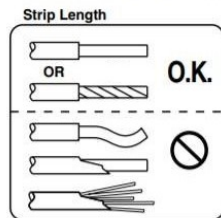

Fig. 7. Wire strip length

3. Position and level the wallplate along the wall and mark the drilling location using a pencil.

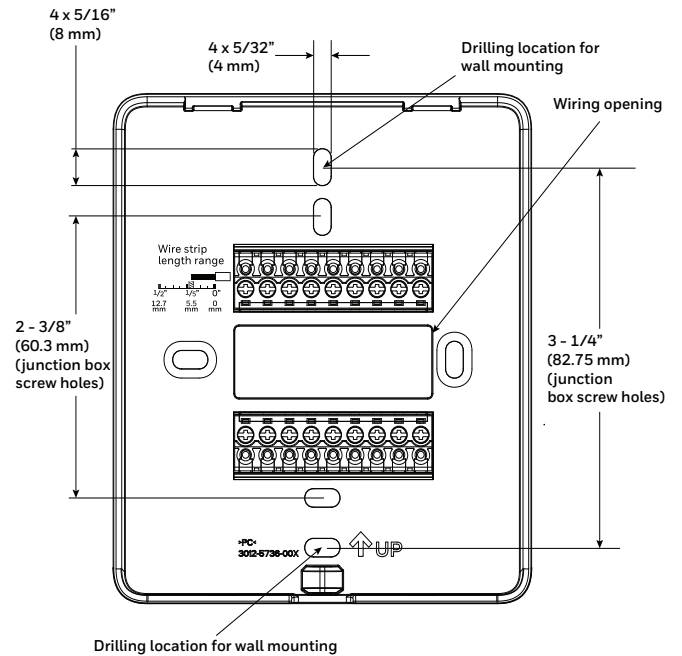

Fig. 8. Wallplate drilling locations

4. Remove the wallplate and drill two pilot holes on the wall, on the marks. For drywall, drill 3/16" (5 mm) holes. For firmer material such as plaster, drill 7/32" (6 mm) holes.
5. Gently tap anchors (provided in the kit) into the pilot holes until flush with the wall.
6. Pull the wires through the wiring opening of the wallplate and position the wallplate over the mounting holes. See Fig. 12 Wiring.
7. Insert the screws into the holes and tighten (screw torque 0.1 Nm).

Mounting the wallplate on the junction box

TC300 thermostats can support vertical mounting of US 2"x4" junction box, vertical and horizontal mounting of 75*75 mm, 86*86 and European round(ø71 for German and ø75 for French) junction boxes.

NOTE: Use TC300 Deco plate for mounting if you are not using US 2"x4" or UK 75*75 mm junction boxes. Refer to the Deco plate pocket guide (31-00657).

1. Install the junction box and perform the wiring as per its manufacturer's instructions.

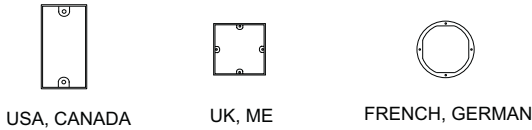

Fig. 9. Various junctions boxes

2. Before mounting the wallplate, make sure that the thermostat wires are stripped to the length marked on the wallplate.
3. Pull the wires through the wiring opening of the wallplate and position the wallplate along the junction box to align the mounting holes. For junction box screw holes, refer to Fig. 8.
4. Insert the screws into the holes and tighten them.

Terminal layout TC30xB / TC32xB (24 VAC)

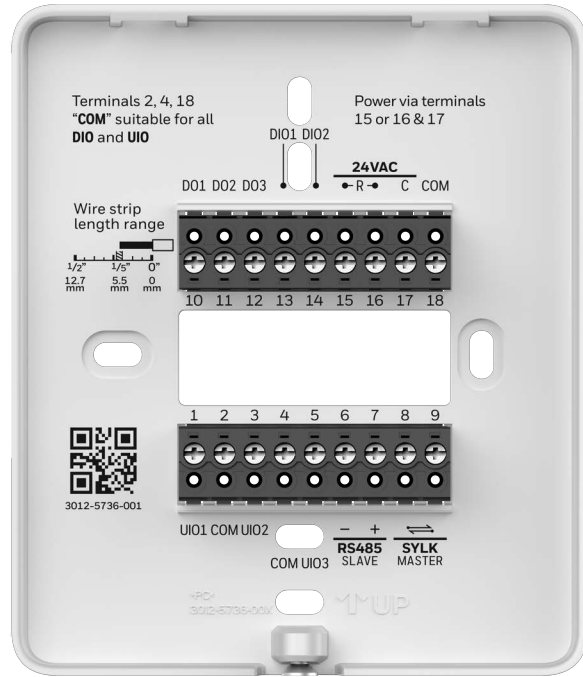

Fig. 10. Thermostat terminal assignments

⚠ WARNING
Do NOT wire the thermostat to line voltage.

Table 2. Terminal Identification

Terminal Name	Terminal Number	Terminal Label	Description
UIO1	1	UIO1	Universal input/output
COM	2	COM	Common
UIO2	3	UIO2	Universal input/output
COM	4	COM	Common
UIO3	5	UIO3	Universal input/output
RS485 SLAVE	6	-	BACnet/Modbus Communications
RS485 SLAVE	7	+	BACnet/Modbus Communications
SYLK MASTER	8	↔	Sylk bus
SYLK MASTER	9	↔	Sylk bus
DO1	10	DO1	Relay output

Table 2. Terminal Identification (Continued)

Terminal Name	Terminal Number	Terminal Label	Description
DO2	11	DO2	Relay output
DO3	12	DO3	Relay output
DIO1	13	DIO1	Relay output Analog input Dry contact digital input
DIO2	14	DIO2	Relay output Analog input Dry contact digital input
24 VAC POWER	15/16	R	24 VAC power from Class2 transformer
24 VAC POWER	17	C	24 VAC common (Neutral) from Class2 transformer
COM	18	COM	Common

Table 3. Terminal Identification

Terminal Name	Terminal Number	Terminal Label	Description
UIO1	1	UIO1	Universal input/output
COM	2	COM	Common
UIO2	3	UIO2	Universal input/output
COM	4	COM	Common
UIO3	5	UIO3	Universal input/output
RS485 SLAVE	6	-	BACnet/Modbus Communications
RS485 SLAVE	7	+	BACnet/Modbus Communications
SYLK MASTER	8	↔	Sylk bus
SYLK MASTER	9	↔	Sylk bus
DO1	10	DO1	Relay output
DO2	11	DO2	Relay output
DO3	12	DO3	Relay output
DO4	13	DO4	Relay output
DO5	14	DO5	Relay output
Line Voltage Hot/Phase	15/16	L	Line - Line voltage power input TC300C-G/ TC320C-G: 100-277 VAC
Line Voltage Neutral	17	N	Neutral - Line voltage power input
Not applicable	18	NC	Not connected

Terminal layout TC30xC / TC32xC

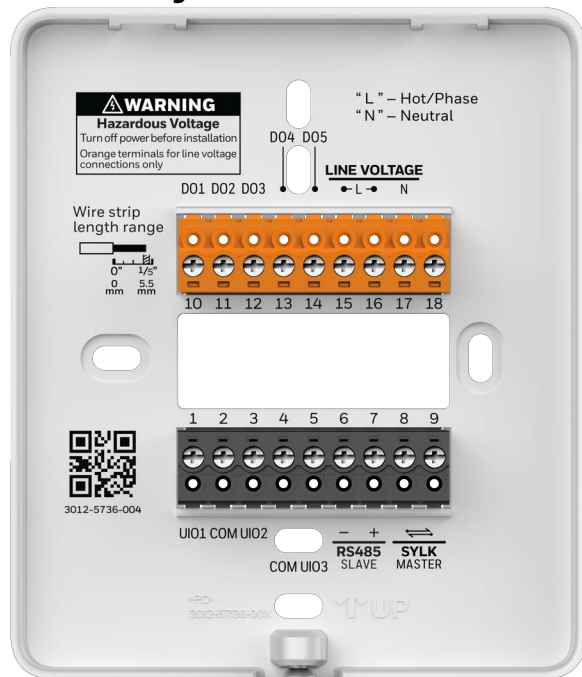

Fig. 11. Thermostat terminal assignments

Accessories ordering part numbers

Table 4. Accessories Part Numbers

TRTC-DECOPLATE-1	TC300 deco plate
------------------	------------------

Wiring the wallplate

IMPORTANT

All wiring must comply with local electrical codes and ordinances.

NOTE: Supports 14-26 AWG (0.2-1.5 mm² for solid or stranded, max 2.5 mm² for solid) wires.

Follow equipment manufacturer wiring instructions when available. A letter code is located near each terminal for identification.



CAUTION

Power must not be connected while wiring.
Wiring a unit that is powered may result in electrical shock and/or equipment damage.

1. Connect wires to the terminals. See Fig. 10 for terminal assignments and Table 2 for terminal descriptions.
2. Loosen the terminal screw, and insert the solid wire (twist if it is stranded) into the wiring terminal hole directly.
3. Tight the terminal screw using the Phillips screwdriver (screw torque 0.4 Nm).

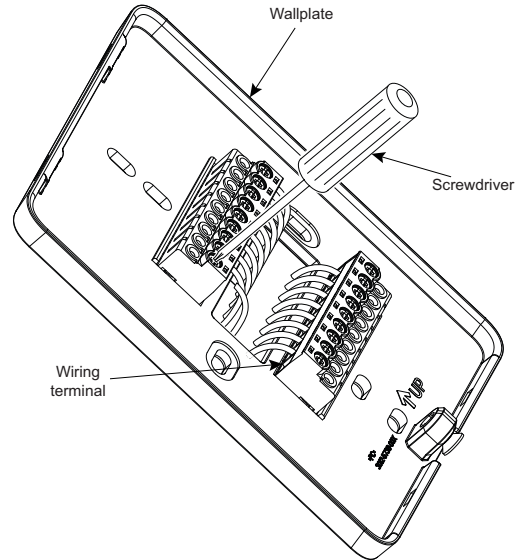

Mounting the display unit

After all wiring is completed, install the display onto the wallplate.

1. Hold the display unit in forward tilted position and align the slots in the display unit with the protrusions on top of the wall plate.

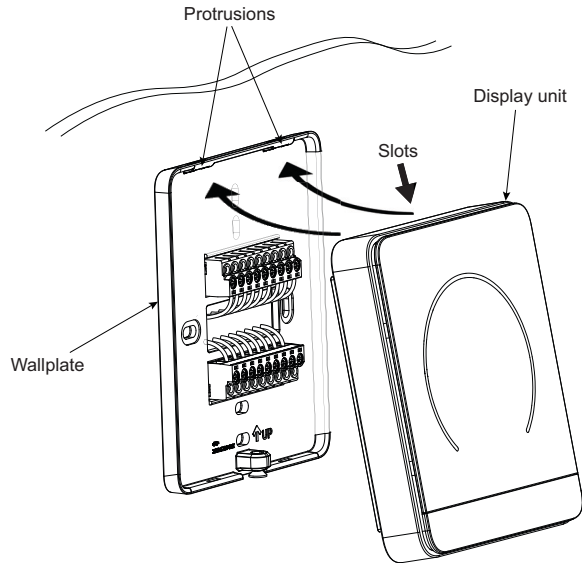

2. Carefully pivot the display onto the wall plate to ensure proper engagement of pins with terminal blocks while ensuring engagement of protrusions and slots is maintained as shown in step 1.

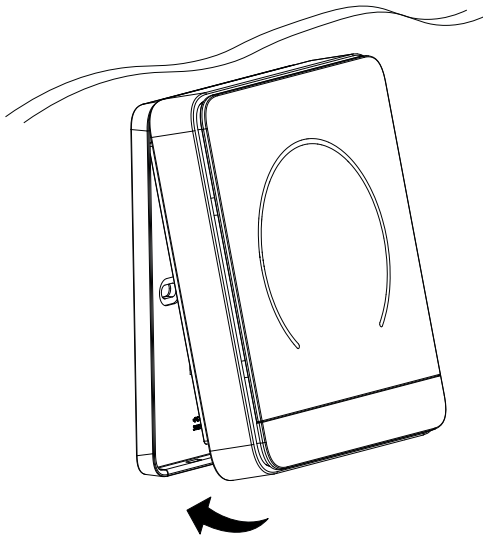

3. Gently tighten the Security screw using a screwdriver by turning it in the clockwise direction (screw torque 0.1 Nm).

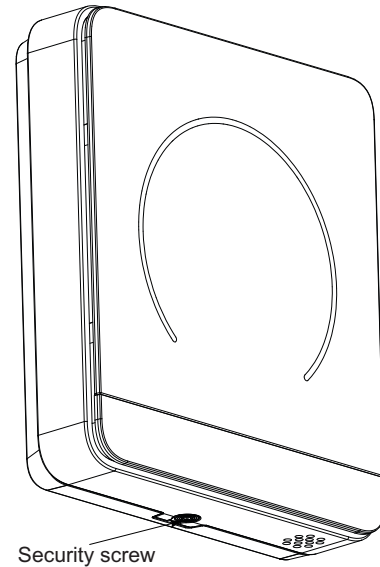

Dismounting the display unit

1. Unscrew the security screw.
2. Detach the bottom side by pulling the display unit out and detach the top side.

TC30xB or TC32xB 24 V equipment terminal assignment

NOTE: L can be connected to 15 or 16, or it can be simultaneously connected to both 15 and 16.

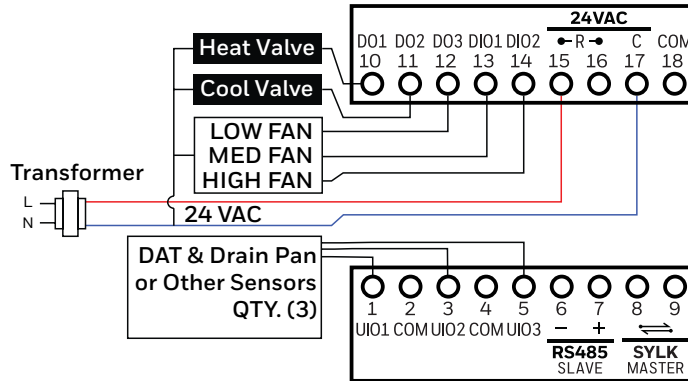

Fig. 13. 4-Pipe FCU, On/Off Valves, 3-Speed Fan

NOTE: L can be connected to 15 or 16, or it can be simultaneously connected to both 15 and 16.

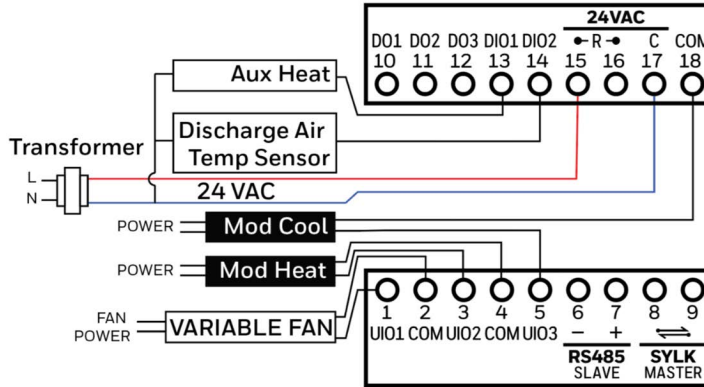

Fig. 14. 4-Pipe FCU, Modulating Valves, Aux. Heat, Var. Speed Fan, Discharge Air Temp. Sensor

Table 5. FCU 4 Pipe Dual coil

Valve Type	Terminal Name and Number							
	DO1	DO2	DO3	DIO1	DIO2	UIO1	UIO2	UIO3
	10	11	12	13	14	1	3	5
On/off heat, On/off cool	*On/off heat	*On/off cool	Low fan	Medium fan	High fan/fan	Variable fan		
			Aux heat	Sensors: Discharge air temp. ¹ & Drain pan or other		Sensors: Discharge air temp. ¹ & Drain pan or other		
Floating heat, Floating cool	*Floating heat open	*Floating heat close	*Floating cool open	*Floating cool close	Single speed fan	Variable fan		
					Aux heat	Sensors: Discharge air temp. ¹ & Drain pan or other		

Table 5. FCU 4 Pipe Dual coil (Continued)

Valve Type	Terminal Name and Number							
	DO1	DO2	DO3	DIO1	DIO2	UIO1	UIO2	UIO3
	10	11	12	13	14	1	3	5
Modulating heat, Modulating cool			Low fan	Medium fan	High fan/fan	Variable fan	Modulating heat	Modulating cool
	Aux heat			Sensors: Discharge air temp. ¹ & Drain pan or other		Sensors: Discharge air temp. ¹ & Drain pan or other		
Modulating heat (stage 1 heat as enable), Modulating cool			Low fan	Medium fan	High fan/fan	Variable fan	Modulating heat	Modulating cool
	*Heat stage 1	Aux heat		Sensors: Discharge air temp. ¹ & Drain pan or other		Sensors: Discharge air temp. ¹ & Drain pan or other		
Modulating heat, Modulating cool (stage 1 cool as enable)			Low fan	Medium fan	High fan/fan	Variable fan	Modulating heat	Modulating cool
	Aux heat	*Cool stage 1		Sensors: Discharge air temp. ¹ & Drain pan or other		Sensors: Discharge air temp. ¹ & Drain pan or other		
Modulating heat (stage 1 heat as enable), Modulating cool (stage 1 cool as enable)			Low fan	Medium fan	High fan/fan	Variable fan	Modulating heat	Modulating cool
	*Heat stage 1	*Cool stage 1	Aux heat	Sensors: Discharge air temp. ¹ & Drain pan or other		Sensors: Discharge air temp. ¹ & Drain pan or other		
On/off heat, floating cool	*On/off heat	*Floating cool open	*Floating cool close	Low fan	High fan/fan	Variable fan		
				Aux heat	Sensors: Discharge air temp. ¹ & Drain pan or other	Sensors: Discharge air temp. ¹ & Drain pan or other		
On/off heat, modulating cool (stage 1 cool as enable)	*On/off heat	*Cool stage 1	Low fan	Medium fan	High fan/fan	Variable fan		Modulating cool
			Aux heat	Sensors: Discharge air temp. ¹ & Drain pan or other		Sensors: Discharge air temp. ¹ & Drain pan or other		

Table 5. FCU 4 Pipe Dual coil (Continued)

Valve Type	Terminal Name and Number							
	DO1	DO2	DO3	DIO1	DIO2	UIO1	UIO2	UIO3
	10	11	12	13	14	1	3	5
Floating heat, on/off cool	*Floating heat open	*Floating heat close	*On/off cool	Low fan	High fan/fan	Variable fan		
				Aux heat	Sensors: Discharge air temp. ¹ & Drain pan or other	Sensors: Discharge air temp. ¹ & Drain pan or other		
Floating heat, modulating cool	*Floating heat open	*Floating heat close	Low fan	Medium fan	High fan/fan	Variable fan		Modulating cool
			Aux heat	Sensors: Discharge air temp. ¹ & Drain pan or other		Sensors: Discharge air temp. ¹ & Drain pan or other		
Float heat, modulating cool (stage 1 cool as enable)	*Floating heat open	*Floating heat close	*Cool stage 1	Low fan	High fan/fan	Variable fan		Modulating cool
				Aux heat	Sensors: Discharge air temp. ¹ & Drain pan or other	Sensors: Discharge air temp. ¹ & Drain pan or other		
Modulating heat, on/off cool		*On/off cool	Low fan	Medium fan	High fan/fan	Variable fan	Modulating heat	Sensors: Discharge air temp. ¹ & Drain pan or other
	Aux heat		Sensors: Discharge air temp. ¹ & Drain pan or other		Sensors: Discharge air temp. ¹ & Drain pan or other			
Modulating heat (stage 1 heat as enable), on/off cool	*Heat stage 1	*On/off cool	Low fan	Medium fan	High fan/fan	Variable fan	Modulating heat	Sensors: Discharge air temp. ¹ & Drain pan or other
			Aux heat	Sensors: Discharge air temp. ¹ & Drain pan or other		Sensors: Discharge air temp. ¹ & Drain pan or other		
Modulating heat, floating cool	*Floating cool open	*Floating cool close	Low fan	Medium fan	High fan/fan	Variable fan	Modulating heat	Sensors: Discharge air temp. ¹ & Drain pan or other
			Aux heat	Sensors: Discharge air temp. ¹ & Drain pan or other		Sensors: Discharge air temp. ¹ & Drain pan or other		

Table 5. FCU 4 Pipe Dual coil (Continued)

Valve Type	Terminal Name and Number							
	DO1	DO2	DO3	DIO1	DIO2	UIO1	UIO2	UIO3
	10	11	12	13	14	1	3	5
Modulating heat (stage 1 heat as enable), float cool	*Floating cool open	*Floating cool close	*Heat stage 1	Low fan	High fan/fan	Variable fan	Modulating heat	Sensors: Discharge air temp. ¹ & Drain pan or other
				Aux heat	Sensors: Discharge air temp. ¹ & Drain pan or other	Sensors: Discharge air temp. ¹ & Drain pan or other		

NOTES:

- *Only the specified operation can be configured based on the valve type.
- ¹When configurable I/O is limited may substitute Syk discharge air sensor C7400S for analog sensor.

Table 6. FCU 4 Pipe Single coil

Valve Type	Terminal Name and Number							
	DO1	DO2	DO3	DIO1	DIO2	UIO1	UIO2	UIO3
	10	11	12	13	14	1	3	5
On/off valve, Changeover valve	*On/off valve	Change-over valve	Low fan	Medium fan	High fan/fan	Variable fan		
			Aux heat	Sensors: Discharge air temp. ¹ & Drain pan or other		Sensors: Discharge air temp. ¹ & Drain pan or other		
Modulating valve, Changeover valve		Change-over valve	Low fan	Medium fan	High fan/fan	Variable fan	Modulating valve	Sensors: Discharge air temp. ¹ & Drain pan or other
			Aux heat	Sensors: Discharge air temp. ¹ & Drain pan or other		Sensors: Discharge air temp. ¹ & Drain pan or other		
6-way valve			Low fan	Medium fan	High fan/fan	Variable fan	6-way valve	Sensors: Discharge air temp. ¹ & Drain pan or other
	Aux heat		Sensors: Discharge air temp. ¹ & Drain pan or other		Sensors: Discharge air temp. ¹ & Drain pan or other			

NOTES:

- *Only the specified operation can be configured based on the valve type.
- ¹When configurable I/O is limited may substitute Syk discharge air sensor C7400S for analog sensor.

Table 7. FCU 2 Pipe

Valve Type	Terminal Name and Number							
	DO1	DO2	DO3	DIO1	DIO2	UIO1	UIO2	UIO3
	10	11	12	13	14	1	3	5
On/off valve	*On/off valve	Aux heat	Low fan	Medium fan	High fan/fan	Variable fan		Pipe sensor
				Sensors: Discharge air temp. ¹ & Drain pan or other		Sensors: Discharge air temp. ¹ & Drain pan or other		
Modulating valve		Aux heat	Low fan	Medium fan	High fan/fan	Variable fan	Modulating valve	Pipe sensor
				Sensors: Discharge air temp. ¹ & Drain pan or other		Sensors: Discharge air temp. ¹ & Drain pan or other		Sensors: Discharge air temp. ¹ & Drain pan or other
Floating valve	*Float-ing valve open	*Float-ing valve close	Low fan	Medium fan	High fan/fan	Variable fan		Pipe sensor
			Aux heat	Sensors: Discharge air temp. ¹ & drain pan or other		Sensors: Discharge air temp. ¹ & Drain pan or other		

NOTES:

- *Only the specified operation can be configured based on the valve type.
- ¹When configurable I/O is limited may substitute Syk discharge air sensor C7400S for analog sensor.

Table 8. Conventional

Valve Type	Terminal Name and Number							
	DO1	DO2	DO3	DIO1	DIO2	UIO1	UIO2	UIO3
	10	11	12	13	14	1	3	5
1H1C	*Heat stage 1	*Cool stage 1	Low fan		High fan/fan	Sensors (QTY. 3)		
				Dehumidifier	Humidifier			
2H	*Heat stage 1	*Heat stage 2	Low fan		High fan/fan	Sensors (QTY. 3)		
				Dehumidifier	Humidifier			
2C	*Cool stage 1	*Cool stage 2	Low fan		High fan/fan	Sensors (QTY. 3)		
				Dehumidifier	Humidifier			
Heat only	*Heat stage 1		Low fan		High fan/fan	Sensors (QTY. 3)		
				Dehumidifier	Humidifier			
Cool only		*Cool stage 1	Low fan		High fan/fan	Sensors (QTY. 3)		
				Dehumidifier	Humidifier			

Table 9. Heat pump

Valve Type	Terminal Name and Number							
	DO1	DO2	DO3	DIO1	DIO2	UIO1	UIO2	UIO3
	10	11	12	13	14	1	3	5
Water source	*Heat /cool stage 1	*Reversing valve	Water flow valve	Low fan	High fan/fan	Proof of waterflow	Other sensors	
			Aux heat	Dehumidifier	Humidifier			
Air source	*Heat /cool stage 1	*Reversing valve	Low fan		High fan/fan	Outdoor air temp.	Other sensors	
			Aux heat	Dehumidifier	Humidifier			

NOTE: *Only the specified operation can be configured based on the valve type.

TC30xC / TC32xC 100-240 VAC equipment terminal assignment

NOTE: L can be connected to 15 or 16, or it can be simultaneously connected to both 15 and 16.

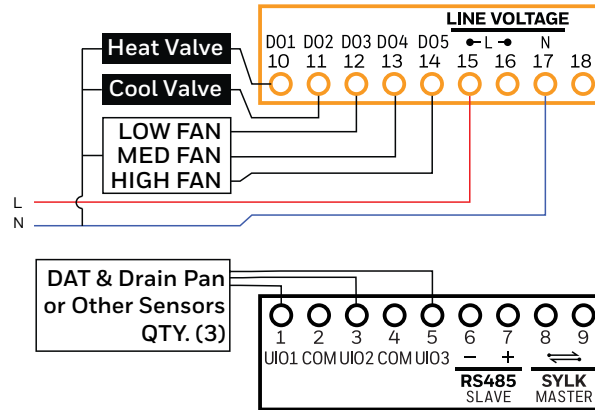

Fig. 15. 4-Pipe FCU, On/Off Valves, 3-Speed Fan

NOTE: L can be connected to 15 or 16, or it can be simultaneously connected to both 15 and 16.

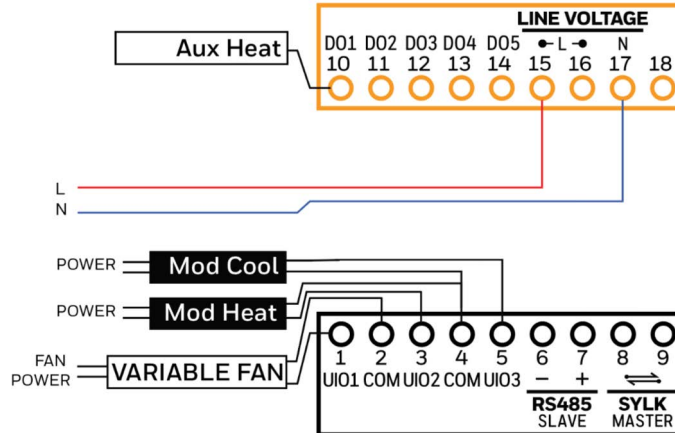

Fig. 16. 4-Pipe FCU, Modulating Valves, Aux. Heat, Var. Speed Fan, Discharge Air Temp. Sensor

Table 10. FCU 4 Pipe dual coil

Valve Type	Terminal Name and Number							
	DO1	DO2	DO3	DO4	DO5	UIO1	UIO2	UIO3
	10	11	12	13	14	1	3	5
On/off heat, On/off cool	*On/off heat	*On/off cool	Low fan	Medium fan	High fan/fan	Variable fan		
			Aux heat			Sensors: Discharge air temp. ¹ & Drain pan or other		
Modulating heat, Modulating cool			Low fan	Medium fan	High fan/fan	Variable fan	Modulating heat	Modulating cool
		Aux heat				Sensors: Discharge air temp. ¹ & Drain pan or other		
Modulating heat (stage 1 heat as enable), modulating cool	*Heat stage 1		Low fan	Medium fan	High fan/fan	Variable fan	Modulating heat	Modulating cool
		Aux heat				Sensors: Discharge air temp. ¹ & Drain pan or other		
Modulating heat, modulating cool (stage 1 cool as enable)	Aux heat	*Cool stage 1	Low fan	Medium fan	High fan/fan	Variable fan	Modulating heat	Modulating cool
						Sensors: Discharge air temp. ¹ & Drain pan or other		
Modulating heat (stage 1 heat as enable), modulating cool (stage 1 cool as enable)	*Heat stage 1	*Cool stage 1	Low fan	Medium fan	High fan/fan	Variable fan	Modulating heat	Modulating cool
			Aux heat			Sensors: Discharge air temp. ¹ & Drain pan or other		
On/off heat, mod cool	*On/off heat		Low fan	Medium fan	High fan/fan	Variable fan	Sensors: Discharge air temp. ¹ & Drain pan or other	Modulating cool
		Aux heat						
On/off heat, modulating cool (stage 1 cool as enable)	*On/off heat	*Cool stage 1	Low fan	Medium fan	High fan/fan	Variable fan	Sensors: Discharge air temp. ¹ & Drain pan or other	Modulating cool
			Aux heat					

Table 10. FCU 4 Pipe dual coil (Continued)

Valve Type	Terminal Name and Number							
	DO1	DO2	DO3	DO4	DO5	UIO1	UIO2	UIO3
	10	11	12	13	14	1	3	5
Modulating heat, on/off cool		*On/off cool	Low fan	Medium fan	High fan/fan	Variable fan	Modulating heat	Sensors: Discharge air temp. ¹ & Drain pan or other
	Aux heat							
Modulating heat (stage 1 heat as enable), on/off cool	*Heat stage 1	*On/off cool	Low fan	Medium fan	High fan/fan	Variable fan	Modulating heat	Sensors: Discharge air temp. ¹ & Drain pan or other
			Aux heat					

NOTES:

- *Only the specified operation can be configured based on the valve type.
- ¹When configurable I/O is limited may substitute Syk discharge air sensor C7400S for analog sensor.

Table 11. FCU 4 Pipe Single coil

Valve Type	Terminal Name and Number							
	DO1	DO2	DO3	DO4	DO5	UIO1	UIO2	UIO3
	10	11	12	13	14	1	3	5
On/off valve, Changeover valve	*On/off valve	Change-over valve	Low fan	Medium fan	High fan/fan	Variable fan		
			Aux heat					
Modulating valve, Changeover valve	Aux heat	Change-over valve	Low fan	Medium fan	High fan/fan	Variable fan	Modulating valve	Sensors: Discharge air temp. ¹ & Drain pan or other
6-way valve	Aux heat		Low fan	Medium fan	High fan/fan	Variable fan	6-way valve	Sensors: Discharge air temp. ¹ & Drain pan or other

NOTES:

- *Only the specified operation can be configured based on the valve type.
- ¹When configurable I/O is limited may substitute Syk discharge air sensor C7400S for analog sensor.

Table 12. FCU 2 Pipe

Valve Type	Terminal Name and Number							
	DO1	DO2	DO3	DO4	DO5	UIO1	UIO2	UIO3
	10	11	12	13	14	1	3	5
On/off valve	*On/off valve		Low fan	Medium fan	High fan/fan	Variable fan		Pipe sensor
	Aux heat					Sensors: Discharge air temp. ¹ & Drain pan or other		
Modulating valve			Low fan	Medium fan	High fan/fan	Variable fan		Pipe sensor
	Aux heat					Sensors: Discharge air temp. ¹ & Drain pan or other	Modulating valve	Sensors: Discharge air temp. ¹ & Drain pan or other

NOTES:

- *Only the specified operation can be configured based on the valve type.
- TC30xC / TC32xC line voltage doesn't support floating valve.
- ¹When configurable I/O is limited may substitute Syk discharge air sensor C7400S for analog sensor

Sylk sensor

NOTE: The below image is only for reference, for detailed information, see the Sylk sensor address table.

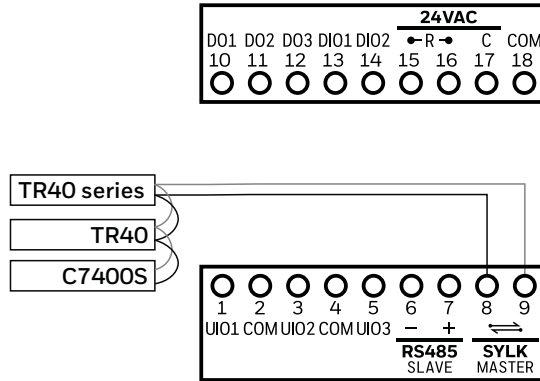

Fig. 17. Sylk sensor address detail

Table 13. Sylk device dip switches

Sylk Address	Device Type	Sensors	DIP Switches
2	Sylk Temperature & Humidity & CO2 sensor	TR40 TR40-H TR40-CO2 TR40-H-CO2	
		TR50-3N TR50-3D	<p>Note: Set the red colored switches to the position as shown in the above image</p>
3	Sylk Temperature sensor	TR40	
4	Sylk Temperature sensor	TR40	
5	Sylk Temperature sensor	TR40	
6	Sylk Wall Module	TR100 as TR75	
8	Outdoor Air Sensor	C7400S	
10	Discharge Air Sensor	C7400S	

NOTE: When configurable I/O is limited may substitute the Sylk sensors for the discharge air, remote temperature, or outdoor air temperature.

DIMENSIONS

Thermostat

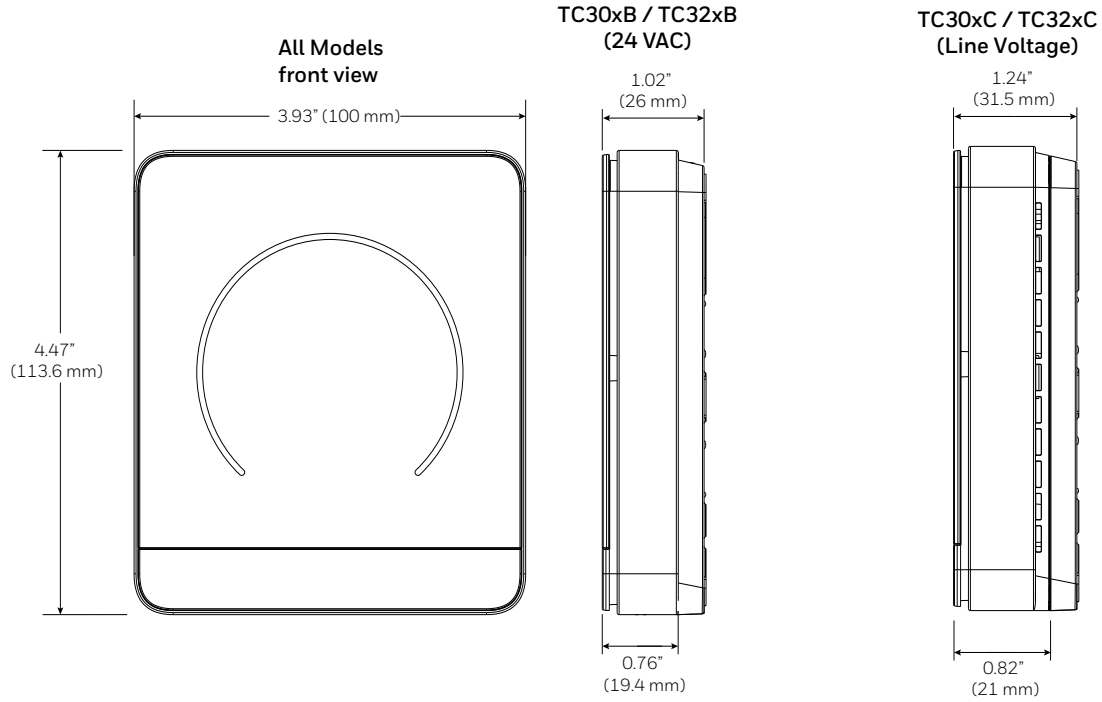

TRTC-Decoplate-1

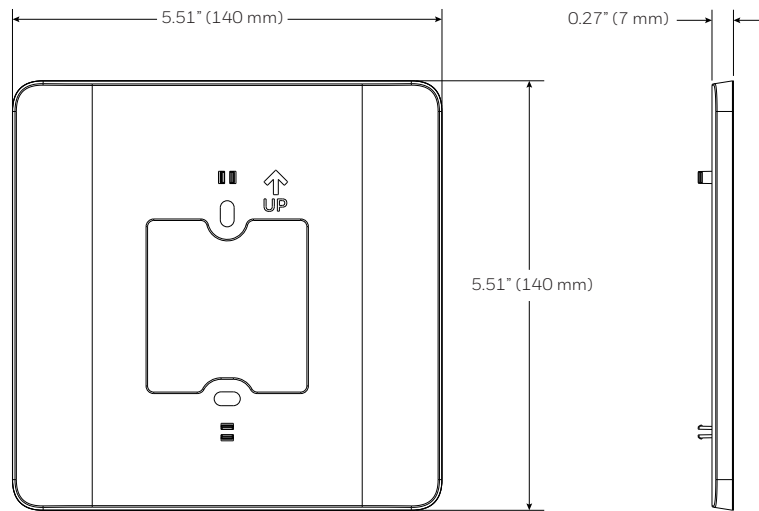

By using this Honeywell literature, you agree that Honeywell will have no liability for any damages arising out of your use or modification to, the literature. You will defend and indemnify Honeywell, its affiliates and subsidiaries, from and against any liability, cost, or damages, including attorneys' fees, arising out of, or resulting from, any modification to the literature by you.

Honeywell | Building Automation

715 Peachtree Street, N.E.,
Atlanta, Georgia, 30308,
United States.

<https://buildings.honeywell.com>

® U.S. Registered Trademark
© 2025 Honeywell International Inc.
31-00642-05 | Rev. 11-25

Honeywell