

# **IQ4/XNC MODBUS Driver Manual**

Applies to version 1.0 software

---

**TREND**

Author: Technical Publications

Issue: 2

Date: 20-Jun-2018

Part Number: TE201379

Copyright: © 2018 Honeywell Products and Solutions SARL, Connected Building Division. All rights reserved.

This manual contains proprietary information that is protected by copyright. No part of this manual may be reproduced, transcribed, stored in a retrieval system, translated into any language or computer language, or transmitted in any form whatsoever without the prior consent of the publisher.

Manufactured for and on behalf of the Connected Building Division of Honeywell Products and Solutions SARL, La Pièce, 16, 1180 Rolle, Switzerland by its Authorized Representative, Trend Control Systems Limited.

For information contact:

Trend Control Systems Limited  
St. Mark's Court  
North Street  
Horsham  
West Sussex  
RH12 1BW

NOTICE: Trend Control Systems Limited makes no representations or warranties of any kind whatsoever with respect to the contents hereof and specifically disclaims any implied warranties of merchantability or fitness for any particular purpose. Trend Control Systems Limited shall not be liable for any errors contained herein or for incidental or consequential damages in connection with the furnishing, performance or use of this material. Trend Control Systems Limited reserves the right to revise this publication from time to time and make changes in the content hereof without obligation to notify any person of such revisions or changes.

Please send any comments on this or any other Trend technical publication to [techpubs@trendcontrols.com](mailto:techpubs@trendcontrols.com)

---

**TABLE OF CONTENTS**

<b>1</b>	<b>ABOUT THIS MANUAL</b> .....	<b>5</b>
1.1	Conventions used in this Manual.....	5
1.2	Contacting Trend .....	5
<b>2</b>	<b>ABOUT THE IQ4/XNC MODBUS DRIVER</b> .....	<b>7</b>
2.1	Variants .....	7
2.2	Configuration .....	7
2.3	Connection to Modbus.....	8
2.4	Compatibility .....	8
<b>3</b>	<b>INSTALL THE IQ4/XNC MODBUS DRIVER FILES</b> .....	<b>9</b>
<b>4</b>	<b>CONFIGURATION PROCESS</b> .....	<b>11</b>
4.1	Configure the Driver Using a Solution .....	11
4.2	Configure the Driver by Adding an IQ4/XNC to the Project .....	12
<b>5</b>	<b>CONNECT THE IQ4/XNC TO THE MODBUS DEVICES</b> .....	<b>13</b>
5.1	Connect to the MODBUS Devices Using a Serial Connection.....	13
5.2	Connect to the MODBUS Devices Using a TCP/IP Connection .....	14
<b>6</b>	<b>CONFIGURE THE IQ4/XNC MODBUS DRIVER</b> .....	<b>15</b>
6.1	Select the Driver .....	15
6.2	Add the Driver to the IQ4/XNC .....	16
6.3	Configure the Driver's Communication Settings .....	17
6.4	Configure Device Details.....	18
6.4.1	Specifying the Data Request Code .....	20
6.5	Configure Input/Output Labels.....	26
<b>7</b>	<b>CONFIGURE THE IQ4/XNC STRATEGY</b> .....	<b>27</b>
7.1	Link to the XNC Interface Module's Outputs .....	27
7.2	Link the Strategy to the Comms Status .....	28
7.3	Download the strategy .....	29
	<b>APPENDICES</b> .....	<b>31</b>
<b>A1</b>	<b>CONFIGURATION EXAMPLE</b> .....	<b>31</b>
<b>A2</b>	<b>TROUBLE SHOOTING</b> .....	<b>37</b>



# 1 ABOUT THIS MANUAL

This document refers to the IQ4/XNC MODBUS Serial Driver v1.0, and the IQ4XNC MODBUS TCP/IP Driver v1.0. It describes the process of installing and configuring an IQ4XNC with an MODBUS driver. It is assumed that you are familiar with IQ4 configuration, SET, and MODBUS.

## 1.1 Conventions used in this Manual

This manual uses the following typographic conventions:

<i>Example of Convention</i>	<i>Description</i>
<i>placeholders</i>	Items in italics are placeholders for information that must be supplied (e.g. arguments). Italics are also occasionally used in the text for emphasis.
[[optional items]]	Items inside double square brackets are options.
{choice1 choice2}	Braces and a vertical bar indicate a choice among two or more items. You must choose one or more of these items unless all of the items are also enclosed in double square brackets.

## 1.2 Contacting Trend

### Head Office

Trend Control Systems Limited  
 St. Marks Court  
 North Street  
 Horsham  
 West Sussex  
 RH12 1BW

Tel: +44 (0) 1403 211888  
 Fax: +44 (0) 1403 241608

Details of regional offices can be found on our web site.

### Internet

Our company web site ([www.trendcontrols.com](http://www.trendcontrols.com)) provides information about our products and us. Accredited partners should contact our support web site (<http://pnet.trend-controls.com>).

### Technical Support

Our support department provides technical support during normal office hours. Before contacting our support department ensure you have completed the elearning module (XNC3 Drivers) and e-mailed the results to our training team, by use of the **e-mail results** button on the results page following the test. You must also have your Technical Support PIN number available, without this we will be unable to provide you with any support.

Tel: +44 (0) 1403 226600  
 Email: [trendts@trendcontrols.com](mailto:trendts@trendcontrols.com)  
 Fax: +44 (0) 1403 226310

### Technical Publications

Please send any comments on this or any other Trend technical publication to [techpubs@trendcontrols.com](mailto:techpubs@trendcontrols.com).



## 2 ABOUT THE IQ4/XNC MODBUS DRIVER

The IQ4/XNC MODBUS Driver is a Trend Custom Language (TCL) that enables values from devices on MODBUS to be read into the strategy of an IQ4/XNC. It also enables values from the strategy to be written to values in the MODBUS devices. Data read from the device is stored in the Type 1 (XNC) Interface module's outputs which can be used in the strategy. Data to be written to the device is taken from the IQ4/XNC's Type 1 (XNC) Interface module's inputs which can be modified by the strategy.

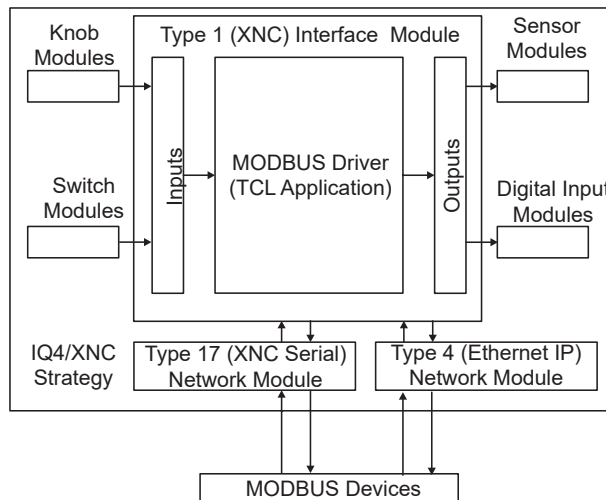

The number of data requests determines the number of different requests for information that can be set up. Each data request could request information for more several sequential values. Each data request is configured in one of the TCL interface module's stores therefore the number of data request is the number of stores available for this purpose.

The data request specifies the device containing the values, the value, and the type of value.

### 2.1 Variants

There are four variants of the driver with different numbers of data requests, inputs, outputs, and different communications options. See the table below.

<i>Communications Option</i>	<i>Data Requests</i>	<i>Inputs</i>	<i>Total Outputs</i>	<i>BrIQs</i>
IP	35	20	85	10005
	185	150	400	12980
Serial	35	20	85	9565
	185	150	400	12540

Each driver variant uses a different number of BrIQs, this allows a different number of devices, and has a different number of outputs

When selecting which driver variant to use you should consider the number of BrIQs available in the IQ4/XNC that is to be used, as well as the method of connecting to the MODBUS, number of data request that are required, the number of outputs required to the strategy and number of inputs required from the strategy. For details of the number of BrIQs available in the IQ4/XNC see the IQ422/.../XNC/... Interface Data Sheet (TA201346).

### 2.2 Configuration

The driver is configured using SET. The configuration involves specifying the values to be read and the TCL interface module's outputs, using codes in the TCL interface module's stores. The TCL interface module's must also be linked the to required place in the controller's strategy, and the strategy configured as required.

The communication settings used in MODBUS are specified in the TCL interface module's stores. This determines the necessary information for communications. In case of TCP/IP variants, this also determines the server that is being used to connect to MODBUS. Other servers can be specified enabling the driver to connect to more than one server.

*Note: The driver can only connect to one server at a time, and a delay of 100s is required when switching between servers.*

### 2.3 Connection to Modbus

Connection to the MODBUS is made from the IQ4/XNC using either a serial connection or a TCP/IP connection.

When connecting using a serial connection the connection between the MODBUS and the IQ4/XNC can be made using either the IQ4/XNC's RS232, or RS485 connector.

When connecting using a TCP/IP connection a MODBUS server is required. Communication between the server and the IQ4/XNC is over Ethernet using the IQ4/XNC's Ethernet connector. If required the driver can connect to more than one server (only one at a time).

*Note: Some MODBUS devices have their own MODBUS server. This means that to obtain data from different devices the driver must change connections this takes at least 100 seconds.*

### 2.4 Compatibility

For details of the supported MODBUS functions, formats for reading and writing word data and compatible IQ4 controllers see the IQ4/XNC MODBUS Driver Data Sheet (TA201377).

### **3           INSTALL THE IQ4/XNC MODBUS DRIVER FILES**

The IQ4/XNC MODBUS Driver solutions are installed as part of the SET 7.0 or greater installation.



## 4 CONFIGURATION PROCESS

Before starting you must have, the documentation supplied with the device, a suitable version of SET, the MODBUS driver for the IQ4/XNC, an IQ4/XNC.

The driver can be loaded into a SET project using a solution from the Strategy Library or by adding an IQ4/XNC to your project and specifying the required driver in the TCL module. Configuring the driver using a solution is the simplest method but requires a standard strategy to have been configured together with the driver. Four solutions are provided within the SET applications library standard solutions for the purpose of getting started or communications testing. Each of these contains sensors, digital inputs, knobs and switches already connected to the outputs and inputs of the TCL module so that data points may be read and written having configured the TCL module stores.

### 4.1 Configure the Driver Using a Solution

The process below describes how to configure the driver using a solution.

**To configure the driver using a solution:**

1. Install the MODBUS devices which are to be communicated with according to the manufacturer’s installation information.
2. Install the IQ4/XNC as described in the supplied installation instructions.
3. Connect the IQ4/XNC to the MODBUS devices - see [“Connect the IQ4/XNC to the MODBUS Devices” on page 13.](#)
4. Choose the required driver - see [“Select the Driver” on page 15.](#)
5. Run SET and view the **Strategy Library**.
6. In the **Standard Solution** area expand ‘IQ4/XNC Drivers’ groups, and open the ‘MODBUS’ sub group. All the solutions for the IQ4/XNC MODBUS Driver are displayed.

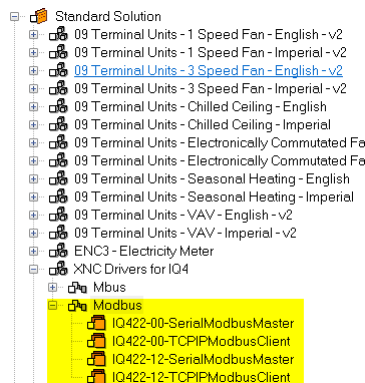

<i>Driver Name</i>	<i>Solution</i>
XactTCPIPModbusClient.XNC	‘IQ422-12-TCPIPModbusClient’ in the ‘Modbus’ sub group of the ‘IQ4’ group in the <b>Standard Solution</b> area.
TCPIPModbusClient.XNC	‘IQ422-00-TCPIPModbusClient’ in the ‘Modbus’ sub group of the ‘IQ4’ group in the <b>Standard Solution</b> area.
XactSerialModbusMaster.XNC	‘IQ422-12-SerialModbusMaster’ in the ‘Modbus’ sub group of the ‘IQ4’ group in the <b>Standard Solution</b> area.
SerialModbusMaster.XNC	‘IQ422-00-SerialModbusMaster’ in the ‘Modbus’ sub group of the ‘IQ4’ group in the <b>Standard Solution</b> area.

7. Right click the required solution, and click **Copy to Project**. The **Enter Destination** dialogue box is displayed.

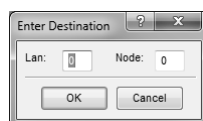

8. In the **Lan** box enter the Lan number for the new controller (0 to 119 excluding addresses 2, 3, and 10).
9. In the **Node** box enter the network address of the controller (1 to 119 excluding addresses 2, 3, and 10).
10. Click **OK**. The controller will be added to the project with the strategy defined in the solution.

- Display a strategy page for the IQ4/XNC, by right-clicking the page, pointing to **Device** and clicking **XNC Interface Module**. The **XNC Interface Module** dialogue box is displayed.

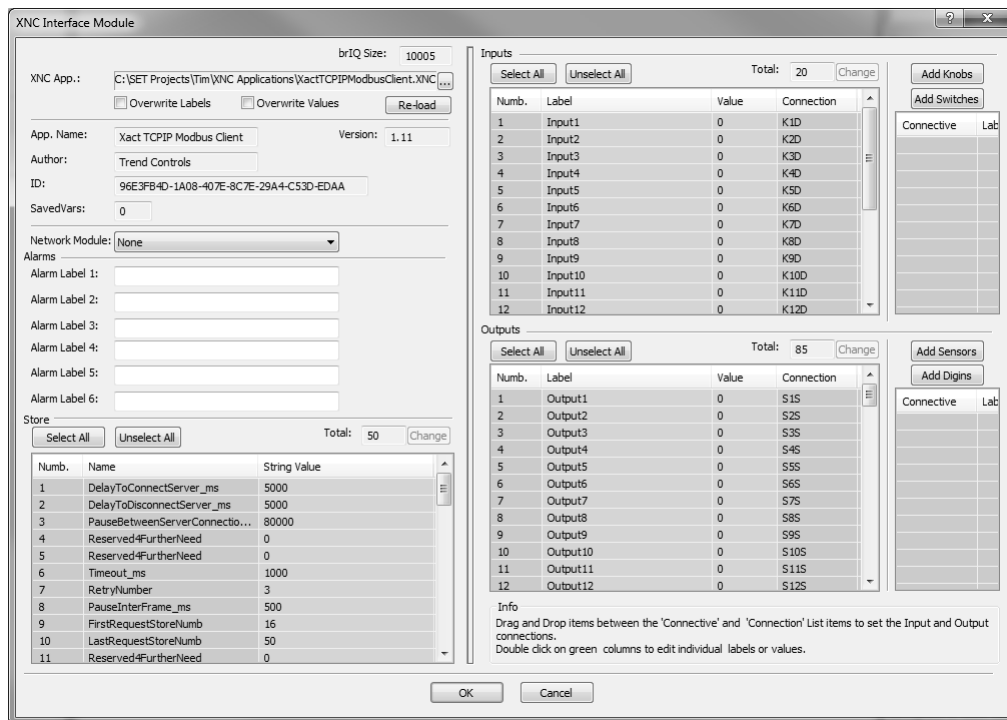

- Configure the driver's communication settings by double-clicking the string value for each store and entering the required value - see the [“Configure the Driver's Communication Settings” on page 17](#).
- Configure the device details by double-clicking the string value for each store and entering the required value - see [“Configure Device Details” on page 18](#).
- Configure the driver's output labels to make identification of the outputs easier by double clicking the output's label in the **Outputs** area, entering the new label and clicking **OK** - see [“Configure Input/Output Labels” on page 26](#).
- Click **OK** to close the **XNC Interface Module** dialogue box.
- Configure the IQ4/XNC's strategy as required. The solution includes digital input and sensor modules already linked to the XNC interface module's outputs. If required you can delete modules linked to outputs you are not using. For details of configuring the strategy of an IQ4/XNC see the SET Manual (TE200147) and [“Configure the IQ4/XNC Strategy” on page 27](#).

If you are reading the comms status from the device it needs to be linked into the strategy as required so that the required action can be carried out. This is done by linking the connective linked to the TCL output to which the comms status is written to the appropriate part of the alarm handling strategy.

- Download the strategy - see [“Download the strategy” on page 29](#).

## 4.2 Configure the Driver by Adding an IQ4/XNC to the Project

When a driver is added using a solution (see [“Configure the Driver Using a Solution” on page 11](#)) the driver is placed in the project directory. This enables it to be manually added to the controller's Type 1 (XNC) Interface Module.

### To configure the IQ4/XNC MODBUS Driver by adding an IQ4/XNC to the project:

- Install the device(s) which are to be communicated with according to the manufacturer's installation information.
- Install the IQ4/XNC as described in the supplied installation instructions.
- Connect the IQ4/XNC to the MODBUS devices - see [“Connect the IQ4/XNC to the MODBUS Devices” on page 13](#).
- Configure the driver - see [“Configure the IQ4/XNC MODBUS Driver” on page 15](#).
- Configure the IQ4/XNC's strategy. For details of configuring the strategy of an IQ4/XNC see the SET Manual (TE200147) and [“Configure the IQ4/XNC Strategy” on page 27](#).

## 5 CONNECT THE IQ4/XNC TO THE MODBUS DEVICES

The connection of the IQ4/XNC to the MODBUS devices can be made using either a serial connection or a TCP/IP connection. The type of connection used will determine which variant of the driver is used.

*Note: It is not possible to use RS232 and RS485 connectors at the same time.*

For more details of connection see the appropriate IQ4 installation instructions.

### 5.1 Connect to the MODBUS Devices Using a Serial Connection

The connection between the MODBUS and the IQ4/XNC can be made using either the IQ4/XNC's RS232, or RS485 connector. The RS232 connection is a peer to peer connection with only one MODBUS slave and a maximum distance of 20 m between master and slave. The RS485 connection is limited to 32 slaves with a maximum distance of 1000 m between master and last slave.

**To connect to the MODBUS devices using a serial connection:**

1. Install the IQ4/XNC as described in the supplied installation instructions.
2. Connect the IQ4/XNC to the MODBUS using its RS232 or RS485 connectors as shown below.

RS232 with RJ11 connector

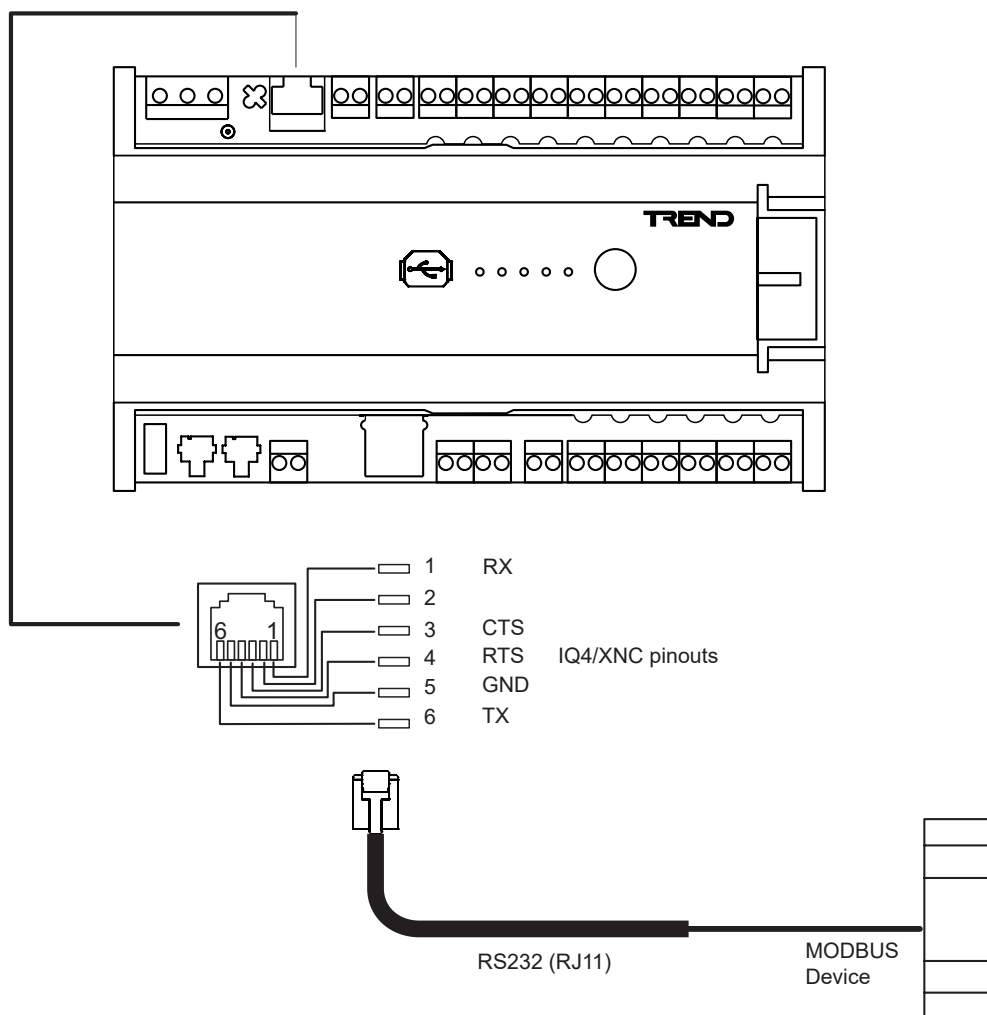

The pinouts shown are those for the IQ4/XNC. The pins from the IQ4/XNC should be wired to the appropriate terminals on the MODBUS device.

# Connect the IQ4/XNC to the MODBUS Devices

2 wire RS485

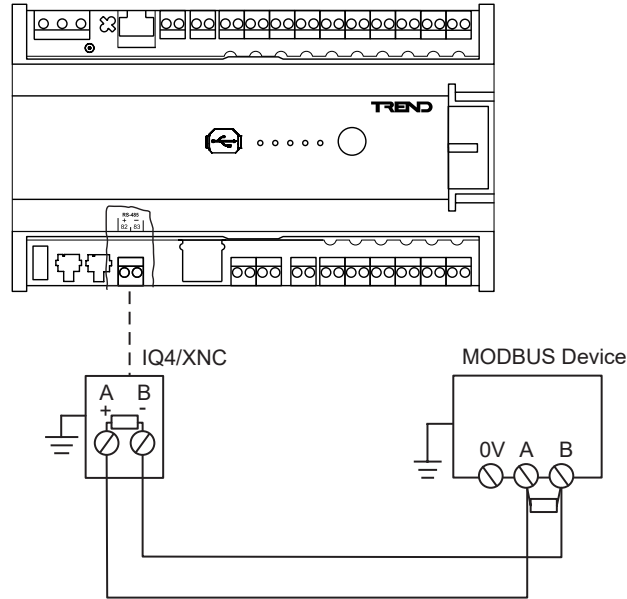

## 5.2 Connect to the MODBUS Devices Using a TCP/IP Connection

When connecting using a TCP/IP connection a MODBUS server is required. Communication between the server and the IQ4/XNC is over Ethernet using the IQ4/XNC's Ethernet connector.

### To connect to the MODBUS devices using a TCP/IP connection:

1. Install the IQ4/XNC as described in the supplied installation instructions ensuring that it is able to communicate on the TCP/Ethernet network.
2. Install the MODBUS server as described in the manufacturer's documentation and connect it to the MODBUS and Ethernet network.

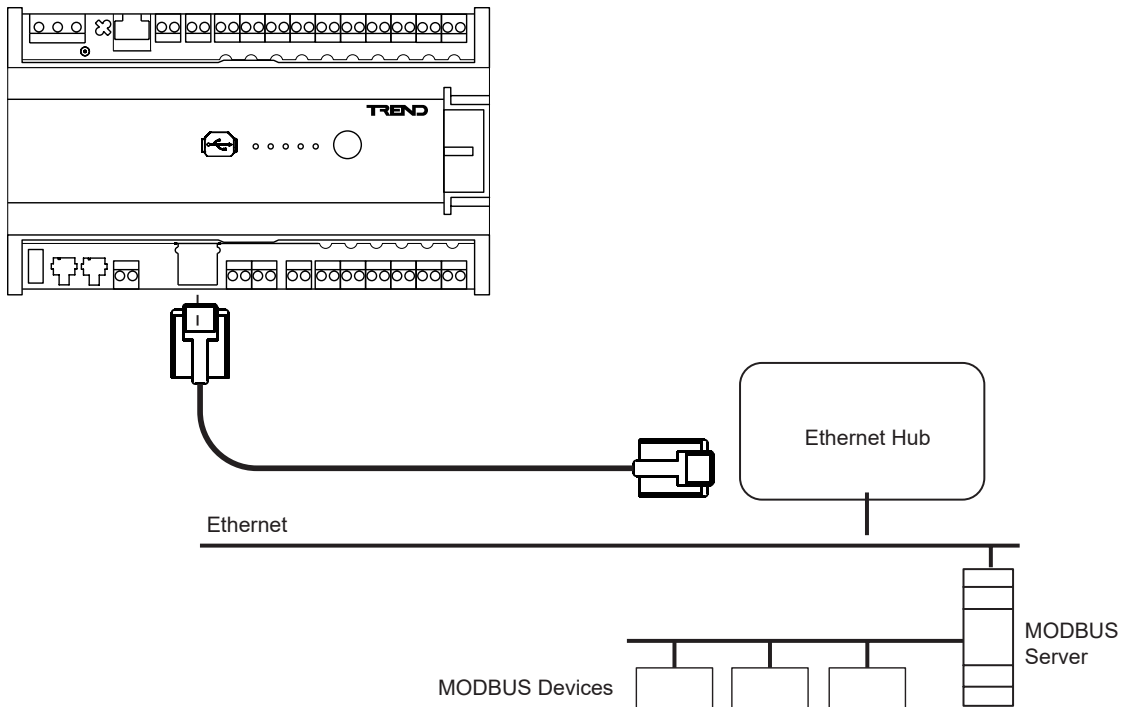

*Note: There must be an IP connection between the IQ4/XNC and the MODBUS server. A MODBUS server may not be a separate device – it may be integrated into the MODBUS device.*

## 6 CONFIGURE THE IQ4/XNC MODBUS DRIVER

Configuration of the IQ4/XNC MODBUS Driver can be broken down into the following steps:

- [Select the Driver](#)
- [Add the Driver to the IQ4/XNC](#)
- [Configure the Driver's Communication Settings](#)
- [Configure Device Details](#)
- [Configure Device Details](#)
- [Configure Input/Output Labels](#)

### 6.1 Select the Driver

The driver is available with two different communications options (TCP/IP, and serial) and in two different sizes. The variants are functionally the same, the only difference is the communications method, the number inputs, and the number of BrIQs required in the IQ4/XNC.

<i>Communications</i>	<i>Data Requests</i>	<i>Total Inputs</i>	<i>Total Outputs</i>	<i>BrIQs Required</i>	<i>Filename</i>
TCP/IP	35	20	85	10005	XactTCPIPModbusClient.XNC
TCP/IP	185	150	400	12980	TCPIPModbusClient.XNC
Serial	35	20	85	9565	XactSerialModbusMaster.XNC
Serial	185	150	400	12540	SerialModbusMaster.XNC

When deciding which variant of the driver to use you should consider the following:

- Communication option
- Number of devices and outputs required
- Driver and strategy size

#### Communication option

Decide which communications option is required (TCP/IP or serial). This depends on the type of converter used to make the connection between the IQ4/XNC and the MODBUS.

#### Number of data request, inputs and outputs required

Consider the data requests, number inputs, and number of outputs that are required and pick a variant of the driver that provides the required level of support.

The number of data requests determines the number of different requests for information that can be set up. Each data request could request information from several sequential values. Each data request is configured in one of the TCL interface module's stores therefore the number of data requests is the number of stores available for this purpose. Information can be written to or read from more actual points than the number of data requests available for the driver as each request may read/write more than one value.

When considering the number of outputs required you should ensure that the selected driver variant has enough outputs for one output per value that is to be read. Remember that a data request that reads 5 values will write the results into 5 consecutive outputs.

When considering the number of inputs required you should ensure that the selected driver variant has enough inputs for one input per value that is to be written. Remember that a data request that writes 4 values will obtain the values to write from 4 consecutive inputs.

*Note that the total number of inputs and outputs cannot exceed the limit for the driver.*

#### Driver and strategy size

As different variants of the IQ4/XNC have a different number of BrIQs available for use for the driver and strategy you must also consider the number of BrIQs required for the driver, and any strategy that is required. If most of the IQ4/XNC's BrIQs are used by the driver there may not be enough available for the strategy. In this case you should consider using the smaller version of the driver with several IQ4/XNCs, or use an IQ4/XNC with a higher BrIQ count.

## 6.2 Add the Driver to the IQ4/XNC

Having selected the required driver as described in the [‘Select the Driver’](#) section of this manual it must be added to the IQ4/XNC.

### To add the driver to the IQ4/XNC:

1. Run SET and open the required SET project, or create a new one as described in the SET Manual (TE200147).
2. Add the required IQ4/XNC to the project as described in the ‘Add Controllers Manually’ section of the SET Manual (TE200147).
3. Display a strategy page for the IQ4/XNC’s strategy.
4. Right-click a strategy page, point to **Device** and click **XNC Interface Module**. The **XNC Interface Module** dialogue box is displayed.

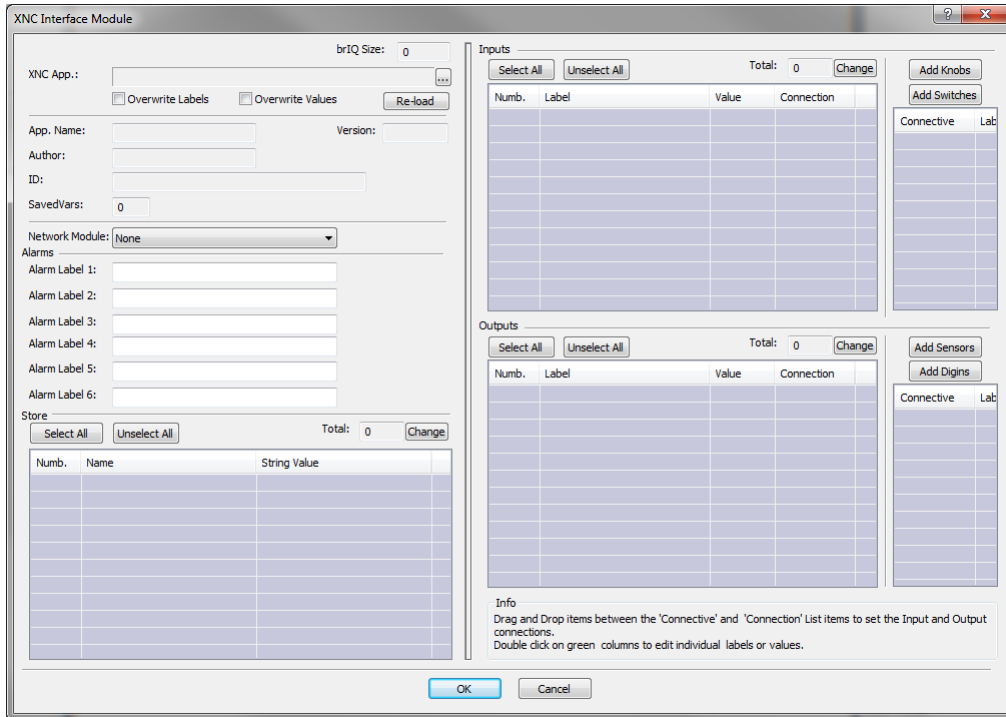

5. Click . The **Select XNC App File** dialogue box is displayed.

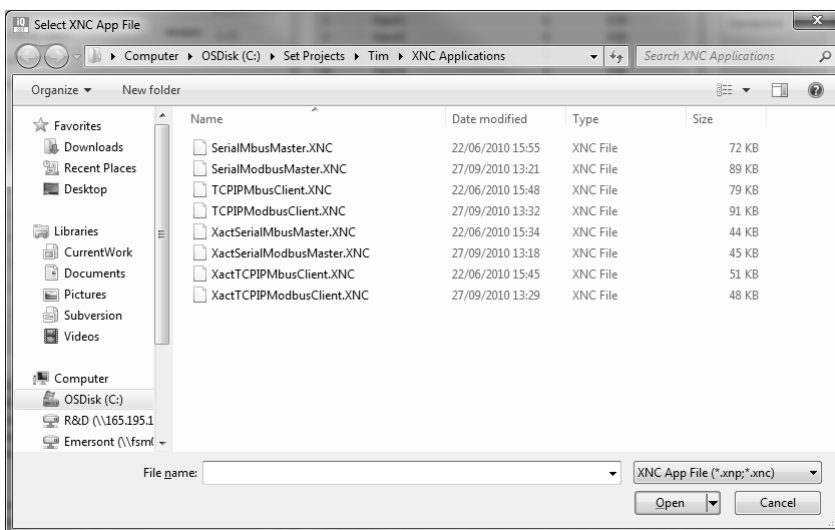

6. Navigate to the ‘c:\program files\trend control systems\xnc applications’ folder by clicking the drive, or folder in the **Look in** box.
7. In the folder list click the file for the required driver.

- Click **Open**. The TCL application for the driver will be loaded. Details of the application’s name, author, and ID are also displayed in the appropriate boxes; all of these are read only.

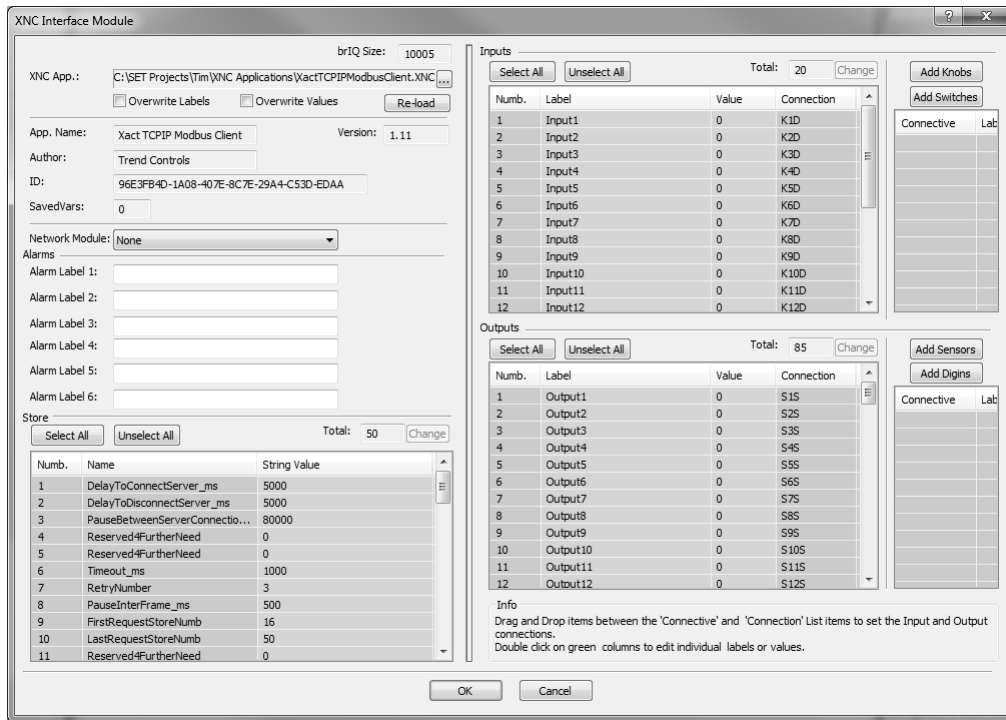

- Check that the correct driver variant has been selected by checking the file specified in the **XNC App** box.
- Click **OK**.

### 6.3 Configure the Driver’s Communication Settings

To configure the driver’s communication settings:

- Run SET, open the SET project, display a strategy page for the IQ4/XNC, right-click a strategy page, point to **Device** and click **XNC Interface Module**. The **XNC Interface Module** dialogue box is displayed.
- Double-click the string value for each store and enter the required value.
- Click **OK**.

Serial Drivers (XactSerialModbusMaster.XNC and SerialModbusMaster.XNC)

The communications settings for the driver’s two serial variants are configured by setting the values of stores 1 to 8.

Store Number	Setting	Description
1	SerialBaudrate_2400_4800_9600_19200	The baud rate of communications between the IQ4/XNC and the MODBUS device. There is no specific upper limit to the baud rate that the XNC will operate at, however particularly complicated strategies combined with high baud rates (particularly those above 19200) should be validated prior to use. Default = 9600.
2	SerialParity_2even_10dd_0none	The parity for communications between the IQ4/XNC and the MODBUS device (range 0, 1, or 2). 0 = no parity, 1 = odd, and 2 = even. Default = 2.
3	SerialDataSize_8_8bits_7_7bits	The number of data bits for communications between the IQ4/XNC and the MODBUS (range 7 or 8). 8 = 8 Bits, 7 = 7 Bits. Default = 8.
4	SerialStopBit_1_1bit_2_2bits	The number of stop bits for communications between the IQ4/XNC and the MODBUS (range 1 or 2). 1 = 1 stop bit, 2 = 2 stop bits. Default = 1.
5	SerialPort_3_RS232_2RS485_1_RS422	The port type for communications between the IQ4/XNC and the MODBUS (range 1, 2, or 3). 1 = RS485 (4-wire), 2 = RS485 (2-wire), 3 = RS232.
6	Timeout_ms	The timeout in milliseconds for communications between the IQ4/XNC and the MODBUS device. Default = 1000

## Configure the IQ4/XNC MODBUS Driver

<i>Store Number</i>	<i>Setting</i>	<i>Description</i>
7	RetryNumber	The number of retries before a COM error is reported. Default = 3
8	PauseInterFrame_ms	The pause in milliseconds between communications frames Default = 500ms

### Communications errors

If the device fails to respond to IQ4/XNC requests for a period greater than the *Timeout\_ms* time the IQ4/XNC3 will try again. If the number of retries reaches the number specified by 'RetryNumber' the COM status output is set to '1'. If communication is successful, it is set to '0'.

### TCP/IP Driver (XactTCPIPModbusClient.XNC and SerialModbusMaster.XNC)

The communications settings for the driver's two TCP/IP variants are configured by setting the values of stores 1, 2, 3, 6, 7, 8 and 15.

<i>Store Number</i>	<i>Setting</i>	<i>Description</i>
1	DelayToConnectServer_ms	The time in milliseconds required to connect to the server (the default value should always be suitable). Default = 5000.  If the MODBUS server does not authorise connection to the IQ4/XNC in the time specified the COM status output specified in store 15 is set to '1'. If the server does authorise the connection to the IQ4/XNC the COM status output is set to '0'.
2	DelayToDisconnectServer	The time required to close the socket (the default value should always be suitable). Default = 5000.
3	PauseBetweenServerConnection_ms	The length of time in milliseconds the driver will wait when the connection to the server is changed.
6	Timeout_ms	The maximum wait time in milliseconds for a response from a MODBUS request. Default = 1000
7	RetryNumber	The number of retries before a COM error is reported. Default = 3
8	PauseInterFrame_ms	The pause in milliseconds between communications frames Default = 500ms
15	ServerAddress#Port#ERR	The IP address of the server containing the MODBUS device information, the TCP port used for the connection, and the output used to store the communications status. The information must be specified in the format below:  ADDR:<IP Address>#<Port Number>#ERR<Output Number>  <IP Address> The server's IP address in the form xxx.xxx.xxx.xxx. <Port Number> The TCP port used for communications. <Output Number> The output the communications status is written to.  E.g. ADDR:192.168.1.1#502#ERR400

## 6.4 Configure Device Details

The device details are the same for all four variants of the driver. They determine the devices that are to be communicated. They are configured by setting the values of stores 9 to 70 or 9 to 200 depending on the driver selected.

### To configure the device details:

1. Run SET, open the SET project, display a strategy page for the IQ4/XNC, right-click a strategy page, point to **Device** and click **XNC Interface Module**. The **XNC Interface Module** dialogue box is displayed.
2. Double-click the string value for each store and enter the required value.
3. Click **OK**.

<i>Store Number</i>	<i>Setting</i>	<i>Description</i>
9	FirstRequestStoreNumber	The number of the store containing the first data request.
10	LastRequestStoreNumber	The number of the store containing the last data request.
16 to 50 or 16 to 200 depending on driver.	Data request	Specifies the value that is to be read from, or written to the MODBUS device. See the ' <a href="#">Specifying the Data Request Code</a> ' section of this manual for more details.

### FirstRequestStoreNumber and LastRequestStoreNumber

These parameters are used to delimit the list of stores containing data request codes. Therefore if you are not using the maximum you should adjust the values appropriately as this will speed up the driver's operation. E.g. if only 10 data requests are being used change the 'LastRequestStoreNumber' to '19'. The 'FirstRequestStoreNumber' parameter should normally be left at the default value of '10' unless during commissioning you want to restrict the data requests to part of the list for fault finding purposes.

## 6.4.1 Specifying the Data Request Code

The data code determines the data that is read from or written to the MODBUS devices.

*Edevice#Ffunction#Aaddress#Nno of values#Ostart output/input#[#ERRerror output]#Cformat#bit order or mask*

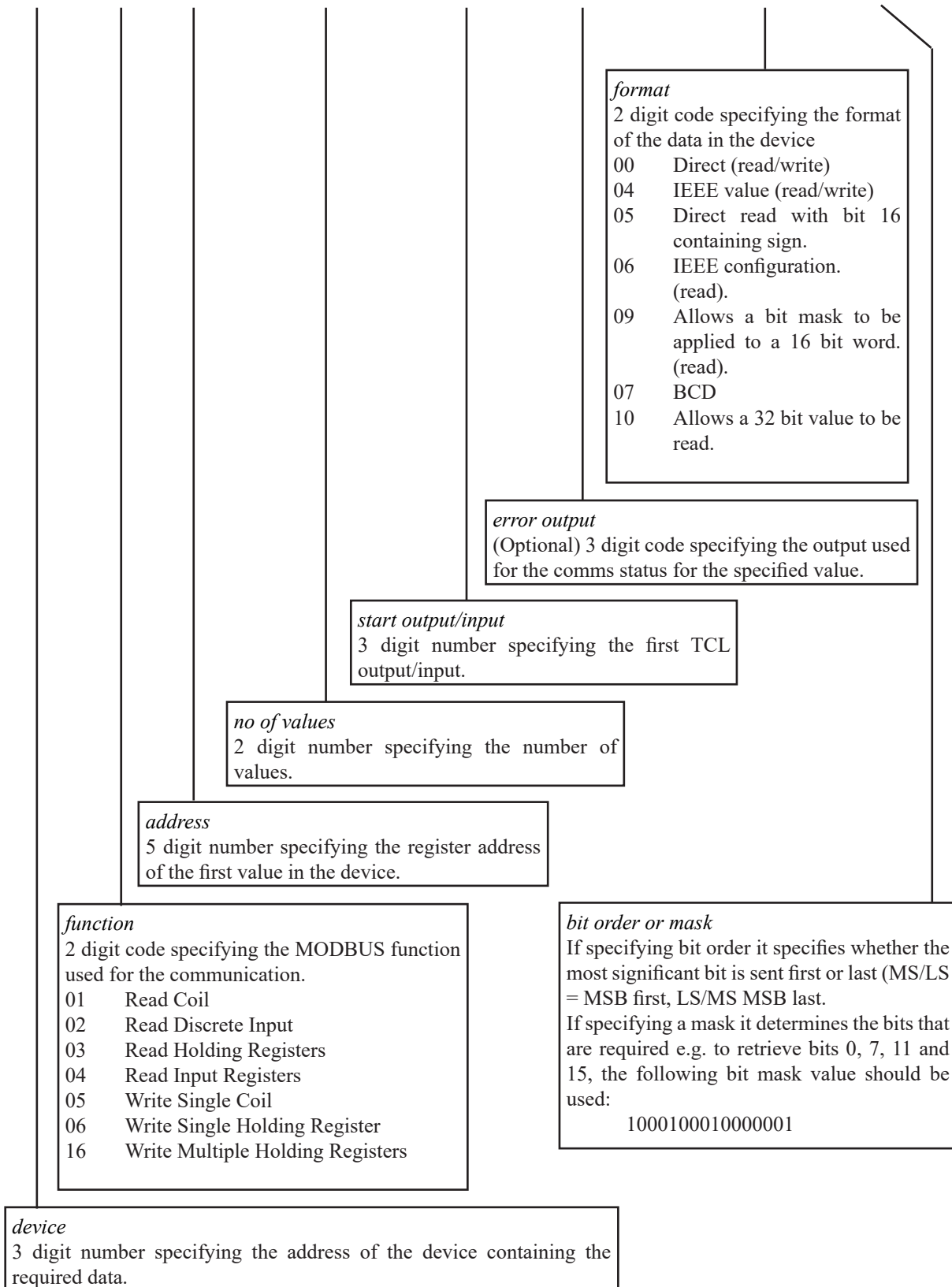

Note that for all codes the specified number of digits MUST be included. If necessary the code should be padded with leading zeros.

*device*: This is a 3 digit number that specifies the address of the device containing the required data. If the address is less than 3 characters it must be padded with leading zeros as required e.g. if the address is '3' you must enter '003'.

*function*: This is a 2 digit code that specifies the MODBUS function that is to be used to send data to or retrieve data from the device. You must enter 2 digits e.g. '03'. The driver supports the following MODBUS functions.

<b>MODBUS Function</b>	<b>Description</b>
01	Multiple-bit read (Read Coil). If used <i>format</i> must be set to '00'.
02	Multiple-bit read (Read Discrete Input)
03	Multiple-word read (Read Holding Registers)
04	Multiple-word read (Read Input Registers)
05	Bit write (Write Single Coil). If used <i>format</i> must be set to '00', and <i>no of values</i> must be set to '01'.
06	Word write (Write Single Holding Register). If used <i>no of values</i> must be set to '01'.
16	Write Multiple Holding Registers

*address*: This is a 5 digit number that specifies the MODBUS address of the first required value in the device. It must be the decimal value not the hexadecimal value. If it is less than 5 digits it must be padded with leading zeros e.g. 512 must be entered as 00512. You should reference the documentation supplied with the MODBUS device for details of what information is stored in what register or address. However the way each manufacturer refers to this information is different. It may be presented as a register number or address and the address may be in decimal or hex. If the information is presented as a MODBUS address in decimal then the value can be used as specified. However if presented as a register number then you should follow the following rule to calculate the address:

- If the value is greater than 9999 then take off the first digit e.g. 40513 becomes 0513.
- Subtract 1.

For example:

<b>Manufacturer's Documentation</b>	<b>Address</b>	<b>Value to enter</b>
40513	512	00512
10001	0	00000
30123	122	00122
00001	0	00000

If the address is in hexadecimal it must be converted to decimal before used. It is suggested that this is done using a calculator with the facility to convert hexadecimal values to decimal. Some examples are shown in the table below.

<b>Manufacturer's Documentation</b>	<b>Address</b>	<b>Value to enter</b>
0x301 or 301H	769	00769
0x1012 or 1012H	4114	04114
0x33B or 33BH	827	00827

*no of values*: This is a 2 digit number that specifies the number of values that are to be accessed. The driver will start with the value specified by *address* and then access the next X values where X is specified by *no of values*. If the C09 format is used this value must be set to '01'. If the number of values is less than 2 digits it must be padded with leading zeros as required e.g. if the number of values is '1' you must enter '01'.

*start output/input*: This is a 3 digit number that specifies first output/input in the TCL module to obtain information from, or to put information in. The driver will start with the output/input specified by <Start TCL Output/Input> and use subsequent inputs/outputs as necessary depending on the amount of data read i.e. *no of values*. If the number is less than 2 digits it must be padded with leading zeros as required e.g. if the number is '001' you must enter '01'.

*error output*: This is an optional 3 digit parameter that specifies the output in the IQ4/XNC's TCL module that the communication status is written to. 0=OK, and 1=error. The driver sets a communication error flag if a valid response to a read request is not received within (Timeout \* RetryNumber) and the maximum number of retries is reached. Therefore communication error handling is only effective for read requests (MODBUS functions 01, 02, 03 or 04). One communication detection per MODBUS device is sufficient. It is recommended that the error output is used so that an alarm can be generated by the strategy if a communications error occurs and appropriate action taken.

## Configure the IQ4/XNC MODBUS Driver

Communication error detection is activated by inserting #ERR followed by the output number to which the error status is to be written between *value* and *no of values*.

The following examples show the data code with error detection and then with error detection activated and the error status written to output 255.

Data codes without error detection:

```
E001#F03#A00001#N02#O006#C00#MS/LS
E001#F03#A05009#N01#O003#C09#1000100010000001
E001#F03#A00007#N01#O008#C04#MS/LS
E001#F01#A00001#N05#O001#C00
```

To activate communication error detection for these requests, and store the communication state (0=OK, 1=error) in output 225 they should be modified as follows:

```
E001#F03#A00001#N02#O006#ERR225#C01#MS/LS
E001#F03#A05009#N01#O003#ERR225#C09#1000100010000001
E001#F03#A00007#N01#O008#ERR225#C04#MS/LS
E001#F01#A00001#N05#O001#ERR225#C00
```

*format*: This is a code that specifies the format of the data in the device and therefore determines how the driver reads it. Refer to the device data sheet to determine which format to use. The driver supports the following formats for reading data:

<i>Format</i>	<i>Description</i>	<i>Number of Bytes used to represent data</i>
00	Direct read. Must be used if <i>function</i> is '01', and '05'. Used for boolean and unsigned 16 bit according to the function code used. If <i>function</i> is '03' data will be read from 2 bytes.	2
04	IEEE value. Data is represented as IEEE and are read from 4 bytes.	4
05	Direct read as signed 16 bit (value range -32767 to +32768).	2
06	IEEE configuration. Used for EM/MPO and SIRIO meters.	4
07	BCD	2
09	Allows a bit mask to be applied to a 16 bit word. E.g. a bit mask retrieving bits 5 and 9 would be 0000001000100000. If used <i>no of values</i> must be set to '01'.	2
10	Allows a 32 bit value to be read. Some electricity meters store values as 32 bit. Only direct read is available for this format. Any conversion should be performed by the strategy in the IQ4/XNC.	4

The driver supports the following formats for writing data:

<i>Format</i>	<i>Description</i>	<i>Number of Bytes used to represent data</i>
00	Direct write. If <i>function</i> is '03' data will be read from 2 bytes.	2
04	IEEE value. Data is represented as IEEE and are read from 4 bytes.	4

<Bit order or Mask> This optional parameter can be used to either specify the bit order of the data (most significant bit first of last) or a bit mask that is used to retrieve specify bits from data. If specifying bit order it specifies whether the most significant byte is sent first or last (MS/LS = MSB first, LS/MS MSB last) e.g.

```
E001#F04#A07680#N04#O001#ERR150#C10#MS/LS
```

The code above specify the data returned has the MSB first.

If specifying a mask it determines the bits that are required e.g. to retrieve bits 0, 7, 11 and 15, the following bit mask value should be used:

```
1000100010000001
15 11 7 0
```

### Specifying a different server (TCP/IP Drivers only)

The data request code normally specifies information that is to be read from or written to the MODBUS device however, for TCP/IP variants of the driver they can also be used to specify a connection to a different server. This allows the driver to connect to several servers in sequence (single communication instance) by using another store to specify a different connection. E.g. If store 15 contained details of the first connection, and store 30 contained details of the second connection. The first connection would be used to retrieve the values specified in stores 16 to 29 and then the second connection would be used to retrieve the values specified in stores 31 and above.

The connection must be specified in the format below:

ADDR:<IP Address>#<Port Number>#ERR<Output Number>

<IP Address> The server's host name, or IP address in the form xxx.xxx.xxx.xxx. <Port Number> The TCP port used for communications. <Output Number> The TCL output the communications status is written to.

e.g.

ADDR:192.165.35.8#30#ERR150

The example above specifies a connection to a server at IP address 192.165.35.8 using port 30 with errors information written to output 150.

*Note that there is a delay when changing servers this can be specified in store 3 'PauseBetweenServerConnection\_ms'.*

#### 6.4.1.1 Data Request Code Examples

##### 6.4.1.1.1 Reading 1 or more values (MODBUS functions 1 and 2)

The example below shows a store configured to read 5 bits starting at MODBUS address 1 in device 1. In this example the IQ4/XNC writes the first bit to output 1, the second bits to output 2, etc.

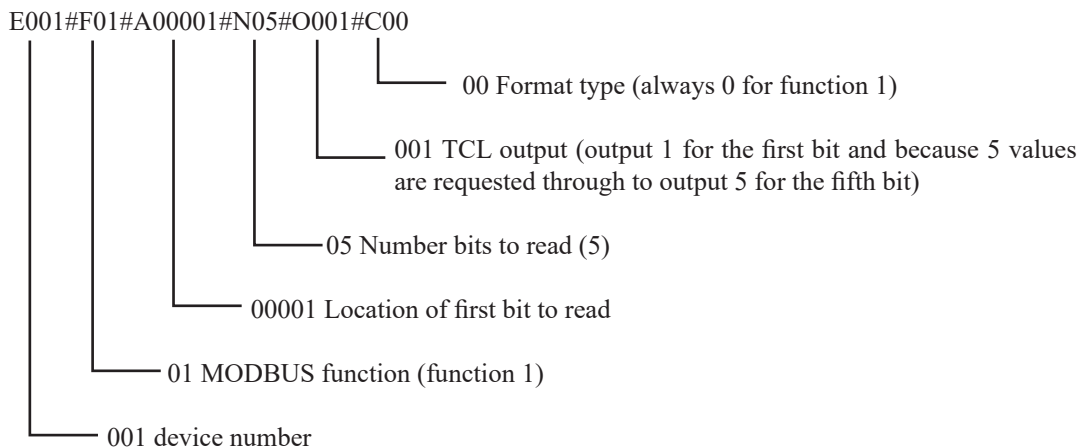

## Configure the IQ4/XNC MODBUS Driver

### 6.4.1.1.2 Reading 1 or more words of 16 bits (MODBUS functions 3 and 4)

The example below shows a store configured to read 2 values (2 words of 16 bits each) starting at MODBUS address 1 in device 1. In this example, the XNC3 writes the first value to output 6 and the second to output 7.

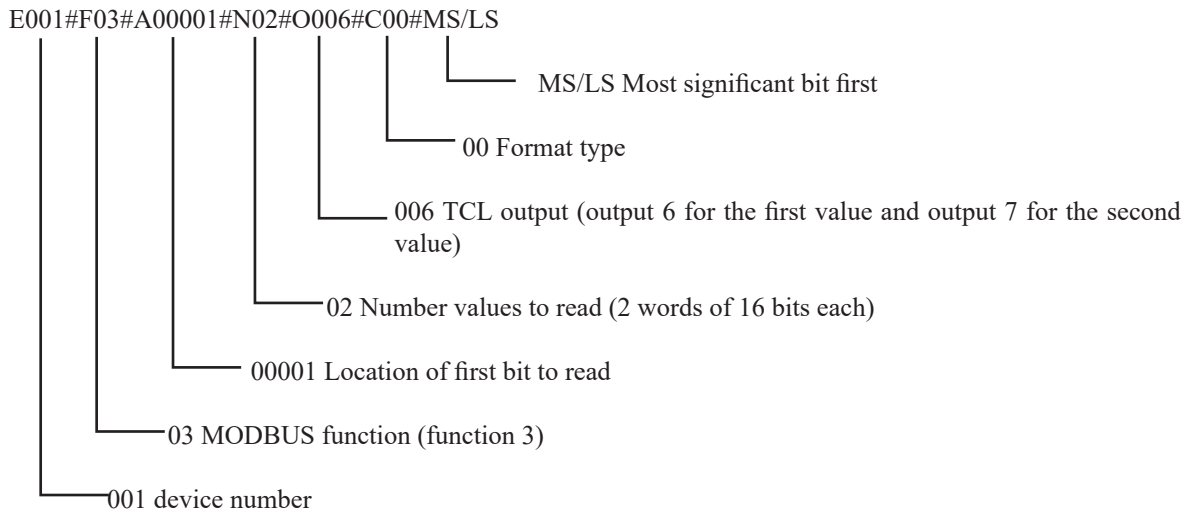

### 6.4.1.1.3 Reading a word with a bit mask (MODBUS functions 3 and 4)

Some manufacturers use a 16 bit word to encode Boolean values. In such cases, functions 3 and 4 should be used as below, with C09 format. The C09 format only allows a single 16 bit word to be read therefore '09' format must be used. A bit mask can be used for selecting the bits desired, to facilitate reading the data. For example, if you need to retrieve bits 0, 7, 11 and 15, the following bit mask value should be used:

1000100010000001 (MSB first).

The example below shows a store configured to read 1 word at MODBUS address 5009 in slave 1. In this example, the XNC3 retrieves the word at address 5009 and applies the mask so as to write the bit 0 value to Output 3, the bit 7 value to Output 4, and so on. This example shows how a bit mask can be used to optimise Output module use.

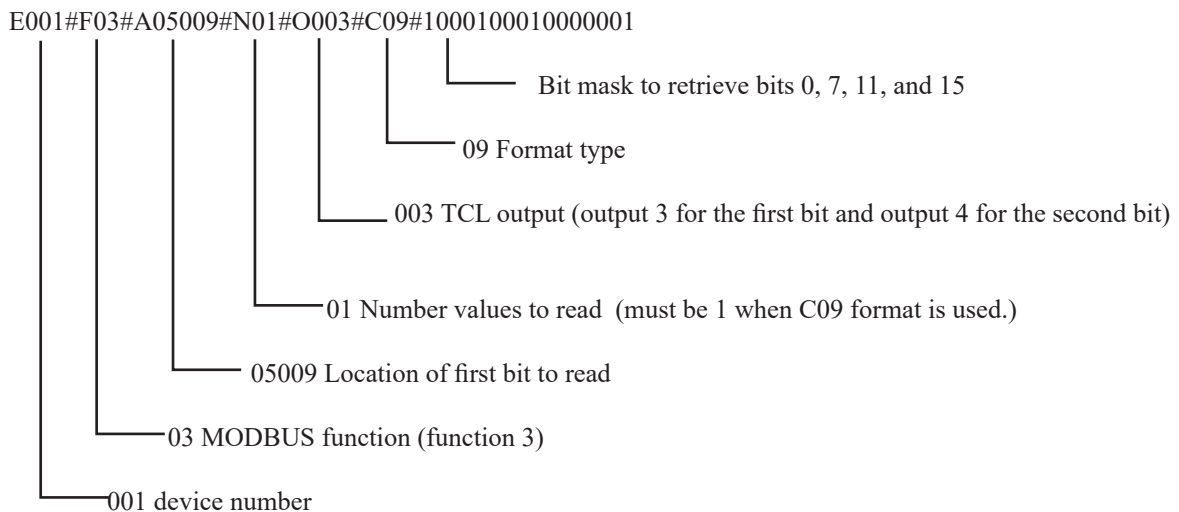

## 6.4.1.1.4 Reading 1 or more IEEE words (MODBUS functions 3 and 4)

The example below shows a store configured to read a single IEEE 754 value at MODBUS address 1 in device 1. The XNC3 writes the value to output 8.

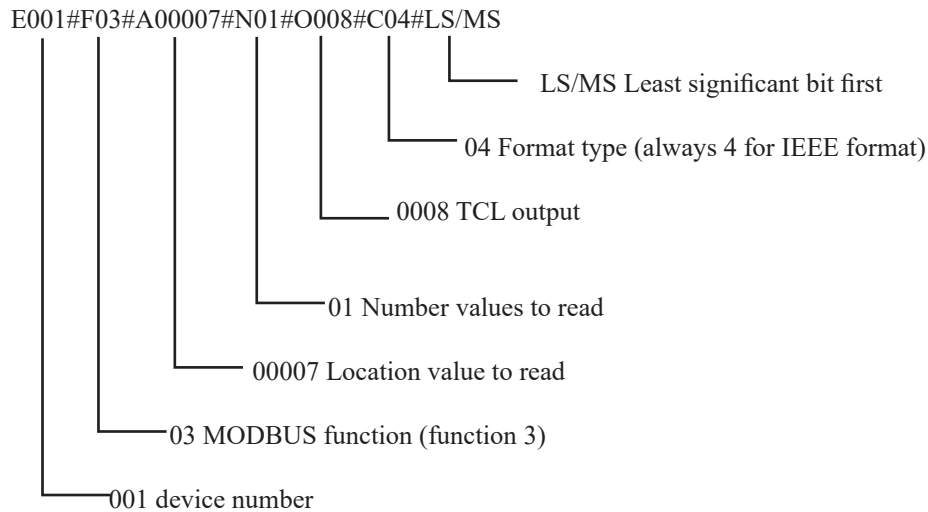

*Note: Some Trend electricity meters do not use the standard IEEE 754 format. For those devices, use the C06 format and not C04. For the EM-MPO SIRIO, the example above would therefore be:*

*E001#F03#A00007#N01#O008#C06#MS/LS*

## 6.4.1.1.5 Bit write. (MODBUS Function 5)

The example below shows a store configured to write 1 bit at MODBUS address 21 in device 1. The IQ4/XNC retrieves the value to write from the TCL input 1.

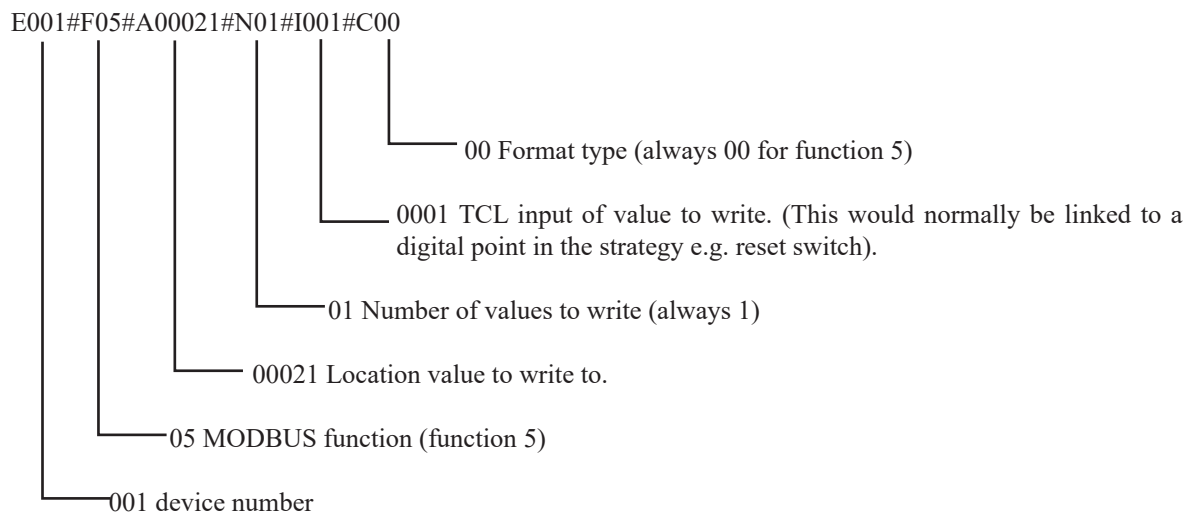

## Configure the IQ4/XNC MODBUS Driver

### 6.4.1.1.6 16 bit word write (MODBUS function 6)

The example below shows a store configured to write 1 word at MODBUS address 20 in device 1. The IQ4/XNC retrieves the value to write from the TCL input 2.

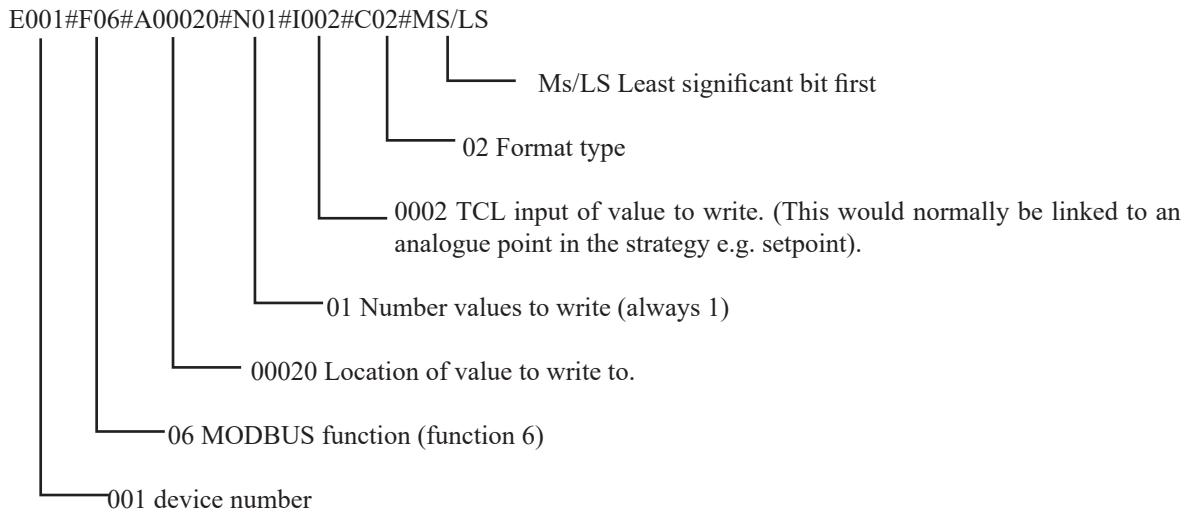

### 6.4.1.1.7 Multiple 16 bit word write (MODBUS function 16)

The example below shows a store configured to write 2 words at MODBUS address 27 in device 1. The IQ4/XNC3 retrieves the first value from TCL input 3 to be written to MODBUS address 27, then the second from TCL input 4 to be written to MODBUS address 28.

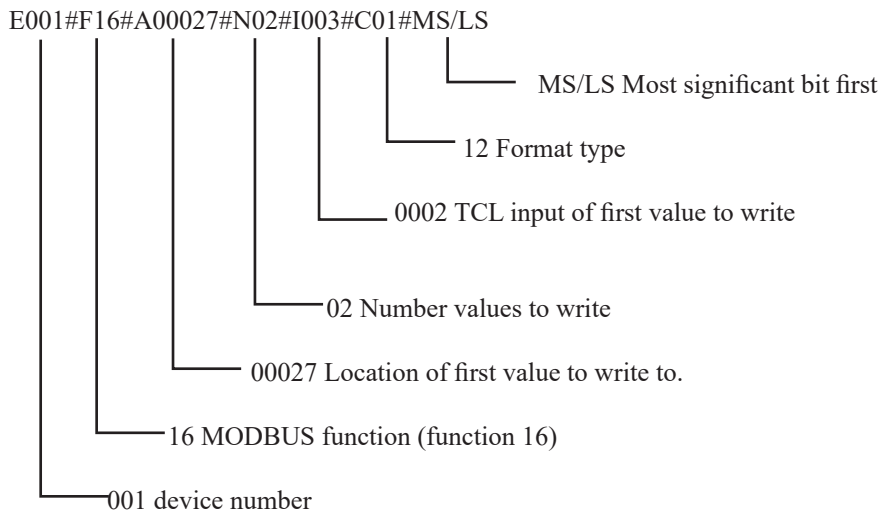

## 6.5 Configure Input/Output Labels

To make identification of the inputs and outputs easier when linking them to the strategy it is recommend that the their labels are configured so that they are understandable. They could be set to match those supplied by the device.

### To configure the input/output labels:

1. Run SET, open the SET project, display a strategy page for the IQ4/XNC, right-click a strategy page, point to **Device** and click **XNC Interface Module**. The **XNC Interface Module** dialogue box is displayed.
2. In the **Inputs** or **Outputs** area double-click on the label that is to be specified.
3. Enter the new label.
4. Click **OK**.

Labels can be copied and pasted by right-clicking on the label and clicking **Copy Label** or **Paste Label**. Labels can be pasted into more than one input, or output by copying the required information to the clipboard, the information for each input or output must be on a new line, selecting the required input or output, right-clicking, and clicking **Paste**. Clicking **Select All** will select all the labels.

## 7 CONFIGURE THE IQ4/XNC STRATEGY

It is necessary to configure the strategy in the IQ4/XNC to process the data from the devices as required. This is done using SET in the normal way to define the strategy as described in the ‘Configure an IQ4/XNC’ section of the SET Manual (TE200147).

Values from the devices are stored in the XNC interface module’s outputs. These are available as connectives for linking to modules in the strategy.





In order to link to the XNC interface module’s outputs it is necessary to add a connective to the required output to a strategy page, and then link the strategy to the connective.

### 7.1 Link to the XNC Interface Module’s Outputs

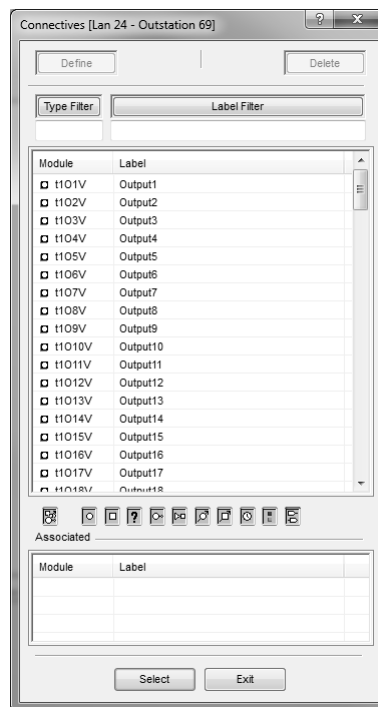
To link to the XNC interface module’s outputs:

1. Run SET and display a strategy page for the IQ4/XNC that is to be configured.
2. Add connectives to the required device values to the strategy.
  - Click . The **Connectives** dialogue box is displayed listing all the XNC interface module’s outputs, modules currently in the strategy, and any nodes that have been defined as connectives.



- Click  to filter the list of connectives so that only the connectives for the TCL inputs are displayed.
  - Click the input that is to be linked.
  - Click **Select**. The cursor changes to a hand .
  - Move the cursor to the position where the connective is to be placed and click. The connective is placed on the page.
  - Click **Exit**.
3. Add the required modules to the strategy page as described in the ‘Add Modules to a Strategy Page’ section of the SET Manual (TE200147).
  4. Link the modules to the required connectives.
    - Click the output of the module that is to be linked to the value.
    - Drag the mouse to the parameter connective linked to the required meter value. If the parameter can be linked the pointer will change to . If the parameter is not a suitable type to be linked the pointer will change to .
    - Release the mouse button.

## Configure the IQ4/XNC Strategy

Sensors and digital inputs modules can be easily added to the strategy and automatically connected to the required output from the **XNC Interface Module** dialogue box using the **Add Sensors** and **Add Diggins** buttons.

### To add sensors or digital input modules:

1. Run SET and open the required SET project, or create a new one as described in the SET Manual (TE200147).
2. Add the required IQ4/XNC to the project as described in the 'Add Controllers Manually' section of the SET Manual (TE200147).
3. Display a strategy page for the IQ4/XNC's strategy.
4. Right-click a strategy page, point to **Device** and click **XNC Interface Module**. The **XNC Interface Module** dialogue box is displayed.

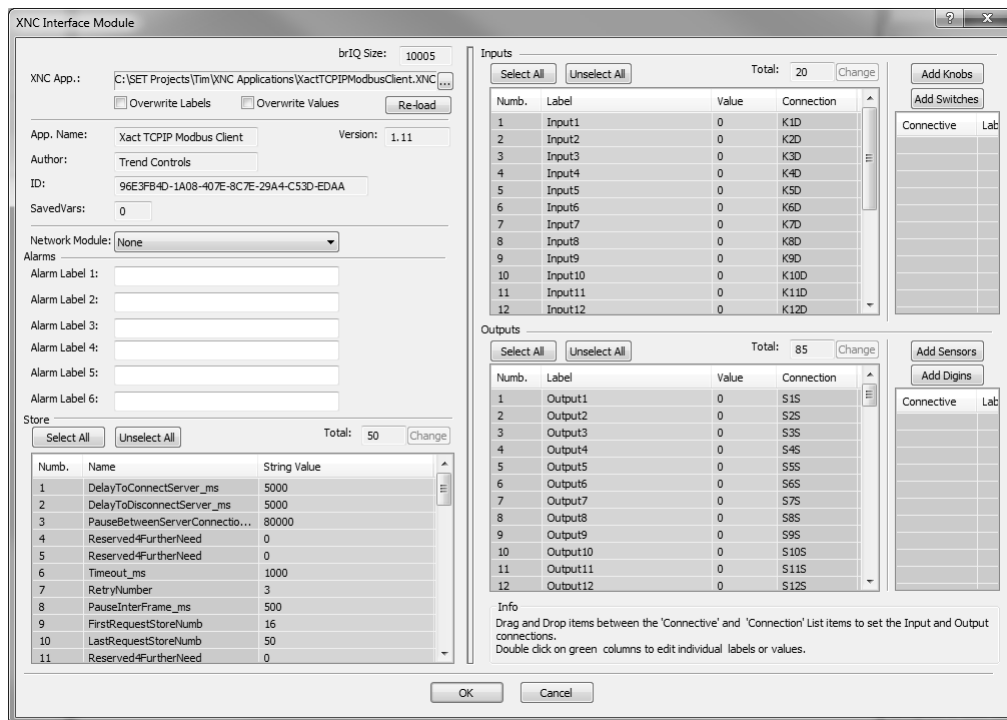

5. Click **Add Sensors** or **Add Diggins** as required. The **Enter Module Range** dialogue box is displayed asking for the number of the sensor or digital input modules that are to be added to the strategy.

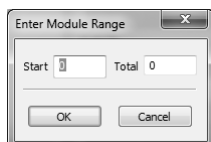

6. In the **Start** box enter the required module number. For a range of modules, enter the first module number that is to be used; subsequent modules will be used for the other outputs in the range.
7. In the **Total** box enter the total number of modules that are being added.
8. Click **OK**. The specified modules linked to the outputs will be added to the strategy page. If the selected strategy page already contains modules a new strategy page will be created.
9. Connect the sensors to the outputs using connectives by dragging the connectives onto the output in the **XNC Interface Module** dialogue box.

## 7.2 Link the Strategy to the Comms Status

If you are reading the comms status from the device it needs to be linked into the strategy as required so that the required action e.g. use a default value of send an alarm can be carried out. This is done by linking the connective linked to the TCL output to which the comms status is written to the appropriate part of the alarm handling strategy

### 7.3 Download the strategy

**To download the strategy:**

1. Download the strategy to the IQ4/XNC as described in the ‘Download Strategy Using SET’ section of the SET Manual (TE200147). Ensure that the XNC File(s) check box is selected.

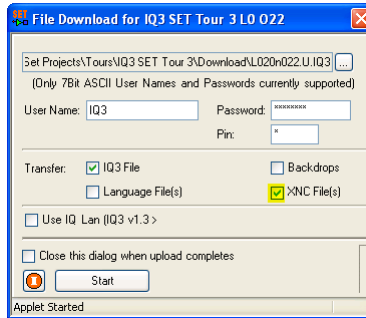

*Note: There is no need to re-load the driver to the XNC in order to apply changes to the strategy. The driver only needs to be done once.*



APPENDICES

A1 CONFIGURATION EXAMPLE

In this example there is one MODBUS meter to be monitored. It is at address 1 on the MODBUS. The meter makes the following information available.

<i>Data Address</i>	<i>Modbus Register</i>	<i>Data</i>	<i>Scaling</i>	<i>No bits</i>
7680	47681	KWh High Word	escale	16
7681	47682	KWh Low Word	escale	16
7682	47683	KVAh High Word	escale	16
7683	47684	KVAh Low Word	escale	16
7684	47685	Kvarh High Word	escale	16
7685	47686	Kvarh Low Word	escale	16
7686	47687	Export kWh High Word	escale	16
7687	47688	Export kWh Low Word	escale	16
7688	47689	Phase 1 Amps	Ki	16
7689	47690	Phase 2 Amps	Ki	16
7690	47691	Phase 3 Amps	Ki	16
7691	47692	Phase 1 Volts	Kvp	16
7692	47693	Phase 2 Volts	Kvp	16
7693	47694	Phase 3 Volts	Kvp	16
7694	47695	Ph1-Ph2 Volts	Kvl	16
7695	47696	Ph2-Ph3 Volts	Kvl	16
7696	47697	Ph3-Ph1 Volts	Kvl	16
7697	47698	Frequency	5000=50.00	16
7698	47699	Phase 1 PF	1000=1.000	16
7699	47700	Phase 2 PF	Kp	16
7700	47701	Phase 2 PF	Kp	16
7701	47702	System PF	Kp	16
7702	47703	Phase 1 kW	Kp	16
7703	47704	Phase 2 kW	Kp	16
7704	47705	Phase 3 kW	Kp	16
7705	47706	System kW	Kp	16
7706	47707	Phase 1 kVA	Kp	16
7707	47708	Phase 2 kVA	Kp	16
7708	47709	Phase 3 kVA	Kp	16
7709	47710	System kVA	Kp	16
7710	47711	Phase 1 kvar	Kp	16
7711	47712	Phase 2 kvar	Kp	16
7712	47713	Phase 3 kvar	Kp	16
7713	47714	System kvar	Kp	16
7723	47724	Peak Ph1 Volts	Kvp	16
7724	47725	Peak Ph2 Volts	Kvp	16
7725	47726	Peak Ph3 Volts	Kvp	16
7726	47727	Kw demand	Kp	16
7727	47728	kVA Demand	Kp	16
7728	47729	kvar Demand	Kp	16
7729	47730	Peak Hold kW Demand	Kp	16
7730	47731	Peak Hold kVA Demand	Kp	16
7731	47732	Peak Hold kvar Demand	Kp	16
7732	47733	Neutral Current	Ki	16
7733	47734	Amps Volts Ki		16
7734	47735	Phase Volts Scale Kvp		16
7735	47736	Line Volts Scale Kvl		16
7736	47737	Power Scale Kp		16
7737	47738	Emergy ke		16

# Configuration Example

An IQ4/XNC with a serial connection to the MODBUS is to be used to run the driver and associated strategy to read information from an electricity meter.

### Install the meter

The meter has been installed following the manufacturer’s instructions and configured to communicate on the MODBUS with the following communications parameters.

- MODBUS address 1
- 9600 baud
- 8 bits
- no parity
- 1 stop bit.

### Install the IQ4/XNC

The IQ4/XNC is installed as described in the supplied installation instructions (TG200766).

### Connect the IQ4/XNC to the MODBUS devices

The IQ4/XNC is connected to the MODBUS via an RS485 2 wire connection as shown below.

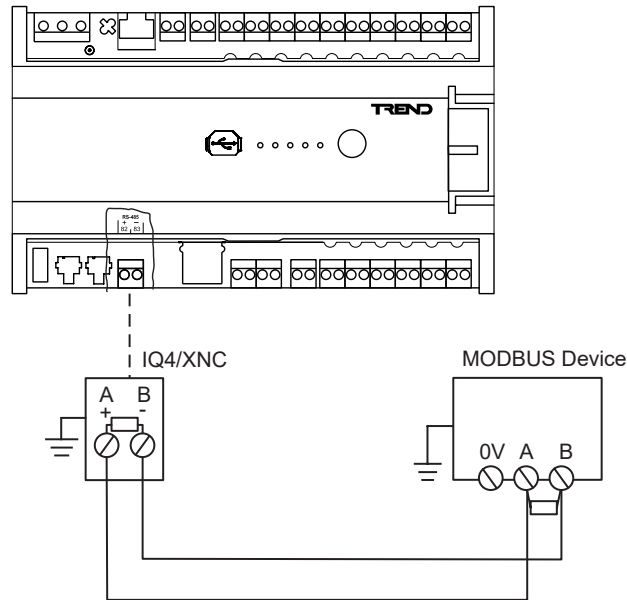

### Select the Driver

The driver selected is the larger serial variant of the driver (SerialMODBUSMaster.XNC) because serial communications are being used.

### Add the Driver to the IQ4/XNC

The driver (SerialMODBUSMaster.XNC) is added to the IQ4/XNC by specifying it in the XNC Interface Module dialogue box in SET.

### Configure the Driver’s Communication Settings

The driver’s communications settings are set up by specifying stores 1 to 8 in the XNC Interface Module dialogue box to the parameters below

Store Number	Setting	Value	Description
1	SerialBaudrate 2400 4800 9600 19200	9600	Set to 9600 as this is the baud rate used by the meter.
2	SerialParity 2even 10dd 0none	0	Set to 0 to specify no parity which is used by the meter.
3	SerialDataSize 8_8bits 7_7bits	8	Set to 8 as this is the number of data bits used by the meter.
4	SerialStopBit 1_1bit 2_2bits	1	Set to 1 as this is the number of stop bits used by the MODBUS devices.
5	SerialPort 2_RS232 2_RS485 1_RS422	2	Set to 2 as this specifies an RS485 2 wire connection which is type of used.

<i>Store Number</i>	<i>Setting</i>	<i>Value</i>	<i>Description</i>
6	Timeout-ms	1000	Left as 1000 as this is suitable for most cases.
7	RetryNumber	3	Left as 3 as this is suitable for most cases.
8	PauseInterFrame_ms	500	Left as 500 as this is suitable for most cases.

### Configure Device Details

The device details configured by setting the values of stores 9 to 200.

<i>Store Number</i>	<i>Setting</i>	<i>Value</i>	<i>Description</i>
9	FirstRequestStoreNumb	16	Left as 16 as this is the store containing first data request code.
10	LastRequestStoreNumb	17	Set to 11 as this is the store containing the last data request. Reducing the number of stores the driver has to look at speeds up operation.
Stores 11 to 15	Not used		
16	Store 10	E001#F03#A07680 #N03#O001#ERR150#C10#MS/LS	<p>Specifies the retrieval of 4 32 bits values stored in data addresses 7680 to 7687 (each value is stored in 2 addresses). MSB first.</p> <p>E001 Specifies the meters address (1)</p> <p>F03 Specifies MODBUS function 03 used for Multiple-word read</p> <p>A07680 the data address of the first value read.</p> <p>N04 The number of values to be read (4 32 bit 2 word values)</p> <p>O001 specifies the first TCL output the results are to be placed in.</p> <p>ERR150 specifies output 150 for the comms error.</p> <p>C10 specifies MODBUS format C10 which is used for reading 32 bit value to be read.</p> <p>MS/LS specifies MSB first</p>
17	Store 11	E001#F04#A07688 #N50#O005#ERR150#C00	<p>Specifies the retrieval of the rest of the data from the meter all value are 16 bit E001 Specifies the meters MODBUS address (1)</p> <p>F04 Specifies MODBUS function 04 for Multiple-word read</p> <p>A07688 the data address of the first value read.</p> <p>N50 The number of values to be read (50 16 bit 1 word values)</p> <p>O005 specifies the first TCL output the results are to be placed in.</p> <p>ERR150 specifies output 150 for the comms error.</p> <p>C00 specifies MODBUS format C00 which is used direct reads</p>
Stores 18 to 200	Not used		

## Configuration Example

---

### Configure Output Labels

The labels of the outputs are configured as shown to match those in the meters to make identification easier.

<i>Output</i>	<i>Label</i>
1	KWh High Word
2	KVAh High Word
3	Kvarh High Word
4	Export kWh High Word
5	Phase 1 Amps
6	Phase 2 Amps
7	Phase 2 Amps
8	Phase 1 Volts
9	Phase 2 Volts
10	Phase 3 Volts
11	Ph1-Ph2 Volts
12	Ph2-Ph3 Volts
13	Ph3-Ph1 Volts
14	Frequency
15	Phase 1 PF
16	Phase 2 PF
17	Phase 2 PF
18	System PF
19	Phase 1 kW
20	Phase 2 kW
21	Phase 3 kW
22	System kW
23	Phase 1 kVA
24	Phase 2 kVA
25	Phase 3 kVA
26	System kVA
27	Phase 1 kvar
28	Phase 2 kvar
29	Phase 3 kvar
30	System kvar
31	Ph1 Amps Demand
32	Ph2 Amps Demand
33	Ph3 Amps Demand
34	Ph1 Volts Demand
35	Ph2 Volts Demand
36	Ph3 Volts Demand
37	Peak Ph1 Amps
38	Peak Ph2 Amps
39	Peak Ph3 Amps
40	Peak Ph1 Volts
41	Peak Ph2 Volts
42	Peak Ph3 Volts
43	Kw demand
44	kVA Demand
45	kvar Demand
46	Peak Hold kW Demand
47	Peak Hold kVA Demand
48	Peak Hold kvar Demand
49	Neutral Current
50	Amps Volts Ki
51	Phase Volts Scale Kvp
52	Line Volts Scale Kvl
53	Power Scale Kp
54	Energy ke

150	Communications Error
-----	----------------------

**Configure Strategy**

The strategy is configured with a sensor for the first 12 outputs plus one for the scaling of ‘Phase 1 volts’ and another for the error status. Each sensor is linked to an output via a connective.

Sensor	Output	Label	Units
1	1	KWh	
2	2	KVAh	
3	3	Kvarh	
4	4	Export kWh	
5	5	Phase 1 Amps	
6	6	Phase 2 Amps	
7	7	Phase 3 Amps	
8	8	Phase 1 Volts	
9	9	Phase 2 Volts	
10	10	Phase 3 Volts	
11	11	Ph1-Ph2 Volts	
12	12	Ph2-Ph3 Volts	
13	51	Phase Volts Scale Kvp	
14	150	Communications Error	

This is done by clicking **Add Sensors** in the **XNC Interface Module** dialogue box and entering 1 as the start sensor, and 14 as the total number of sensors to add the sensors, then dragging the connective to the sensors to onto the outputs. The sensors are added to the strategy on page 3 as shown below.

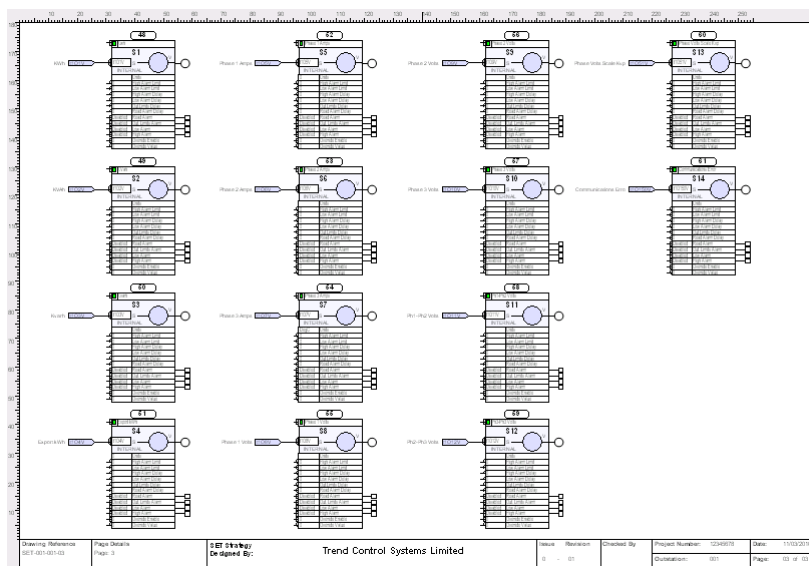

Some strategy is required to correctly scale the value returned form the meter. For the purposes of this example we will only scale the ‘Phase 1 Volts value’. This uses the scaling provided by ‘Phase Volts Scale Kvp’ available form sensor 13. The scaling uses the formula shown below:

$$R=I \times 10^{(K-3)}$$

R = Scaled value

I = returned value (sensor 8)

K = Scaling factor (sensor 13)

## Configuration Example

---

The strategy below is used to scale the value.

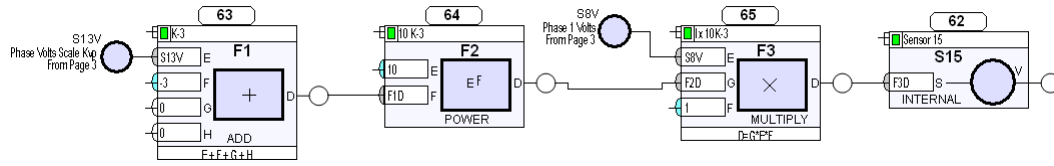



The scaled value is placed in sensor 15.

## A2 TROUBLE SHOOTING

This section provides some help on solving common problems that may occur. For details of the MODBUS Organisation's web site ([www.modbus.org](http://www.modbus.org)). Trend is not responsible for the content of external web sites.

### To view the message frames:

1. Run SET and display the IQ4/XNC in the **System View**.
2. Display the IQ4/XNC's web pages.
3. Click **Modules**.
4. Click **XNC Interfaces**, and click **t1**. A new web browser is displayed.
5. In the **Alarm Reporting LAN** box enter the LAN of the CNC SET is using to connect to the network.
6. In the **Alarm Reporting OS** box enter the network address of the CNC SET is using to connect to the network.
7. Click .
8. In the **Debug Active** box select 'ON', and click .
9. Go to SET's **System View** and right click the site containing the IQ4/XNC and select **Comms window** from the displayed menu. The **Communications** dialogue box is displayed. This will show any communications between the XNC and the MODBUS devices.
10. Analyse the communications to find any faults Knowledge of MODBUS protocol is required.
11. When the analysis is complete in the **Debug Active** box select 'OFF', and click .



## INDEX

## A

About

IQ4/XNC MODBUS Driver .....	<a href="#">7</a>
This Manual .....	<a href="#">5, 7</a>

## B

Baud Rate .....	<a href="#">17, 18</a>
-----------------	------------------------

## C

COM error .....	<a href="#">18</a>
-----------------	--------------------

Configure

Driver Using a Solution .....	<a href="#">11</a>
IQ4/XNC MODBUS Driver .....	<a href="#">15</a>
IQ4/XNC Strategy .....	<a href="#">27</a>

Connect the IQ4/XNC to the MODBUS .....	<a href="#">13</a>
---	--------------------

Contacting Trend .....	<a href="#">5</a>
------------------------	-------------------

## D

Data Bits .....	<a href="#">17</a>
-----------------	--------------------

Download the Strategy .....	<a href="#">29</a>
-----------------------------	--------------------

## I

Install and Configure the IQ4/XNC MODBUS Driver .....	<a href="#">11</a>
---	--------------------

Install the IQ4/XNC MODBUS Driver Files .....	<a href="#">9</a>
---	-------------------

## L

Link the Modules to the Required Connectives .....	<a href="#">27</a>
--	--------------------

Link the XNC Application File .....	<a href="#">16</a>
-------------------------------------	--------------------

## P

Parity .....	<a href="#">17</a>
--------------	--------------------

Port Types .....	<a href="#">17</a>
------------------	--------------------

## R

RS232 .....	<a href="#">17</a>
-------------	--------------------

RS485 .....	<a href="#">17</a>
-------------	--------------------

## S

Server .....	<a href="#">23</a>
--------------	--------------------

Specifying a different server .....	<a href="#">23</a>
-------------------------------------	--------------------

Stop Bits .....	<a href="#">17</a>
-----------------	--------------------

## T

Timeout .....	<a href="#">18</a>
---------------	--------------------

Type 1 (XNC) Interface Module .....	<a href="#">12, 16, 17, 18, 26, 28</a>
-------------------------------------	--





**Trend Control Systems Limited**

St. Mark's Court, North Street, Horsham, West Sussex, RH12 1BW, UK. Tel: +44 (0)1403 211888, [www.trendcontrols.com](http://www.trendcontrols.com)

---