



Annunciator Control Modules
ACM-16ATF
ACM-32AF
Instruction Manual

Fire Alarm System Limitations

An automatic fire alarm system—typically made up of smoke detectors, heat detectors, manual pull stations, audible warning devices, and a fire alarm control with remote notification capability—can provide early warning of a developing fire. Such a system, however, does not assure protection against property damage or loss of life resulting from a fire.

The Manufacturer recommends that smoke and/or heat detectors be located throughout a protected premise following the recommendations of the current edition of the National Fire Protection Association Standard 72 (NFPA 72), manufacturer's recommendations, State and local codes, and the recommendations contained in the Guide for Proper Use of System Smoke Detectors, which is made available at no charge to all installing dealers. A study by the Federal Emergency Management Agency (an agency of the United States government) indicated that smoke detectors may not go off in as many as 35% of all fires. While fire alarm systems are designed to provide early warning against fire, they do not guarantee warning or protection against fire. A fire alarm system may not provide timely or adequate warning, or simply may not function, for a variety of reasons:

Smoke detectors may not sense fire where smoke cannot reach the detectors such as in chimneys, in or behind walls, on roofs, or on the other side of closed doors. Smoke detectors also may not sense a fire on another level or floor of a building. A second-floor detector, for example, may not sense a first-floor or basement fire.

Particles of combustion or "smoke" from a developing fire may not reach the sensing chambers of smoke detectors because:

- Barriers such as closed or partially closed doors, walls, or chimneys may inhibit particle or smoke flow.
- Smoke particles may become "cold," stratify, and not reach the ceiling or upper walls where detectors are located.
- Smoke particles may be blown away from detectors by air outlets.
- Smoke detectors may be drawn into air returns before reaching the detector.

The amount of "smoke" present may be insufficient to alarm smoke detectors. Smoke detectors are designed to alarm at various levels of smoke density. If such density levels are not created by a developing fire at the location of detectors, the detectors will not go into alarm.

Smoke detectors, even when working properly, have sensing limitations. Detectors that have photoelectronic sensing chambers tend to detect smoldering fires better than flaming fires, which have little visible smoke. Detectors that have ionizing-type sensing chambers tend to detect fast-flaming fires better than smoldering fires. Because fires develop in different ways and are often unpredictable in their growth, neither type of detector is necessarily best and a given type of detector may not provide adequate warning of a fire.

Smoke detectors cannot be expected to provide adequate warning of fires caused by arson, children playing with matches (especially in bedrooms), smoking in bed, and violent explosions (caused by escaping gas, improper storage of flammable materials, etc.).

While a fire alarm system may lower insurance rates, it is not a substitute for fire insurance!

Heat detectors do not sense particles of combustion and alarm only when heat on their sensors increases at a predetermined rate or reaches a predetermined level. Rate-of-rise heat detectors may be subject to reduced sensitivity over time. For this reason, the rate-of-rise feature of each detector should be tested at least once per year by a qualified fire protection specialist. *Heat detectors are designed to protect property, not life.*

IMPORTANT! Smoke detectors must be installed in the same room as the control panel and in rooms used by the system for the connection of alarm transmission wiring, communications, signaling, and/or power. If detectors are not so located, a developing fire may damage the alarm system, crippling its ability to report a fire.

Audible warning devices such as bells may not alert people if these devices are located on the other side of closed or partly open doors or are located on another floor of a building. Any warning device may fail to alert people with a disability or those who have recently consumed drugs, alcohol or medication. Please note that:

- Strobes can, under certain circumstances, cause seizures in people with conditions such as epilepsy.
- Studies have shown that certain people, even when they hear a fire alarm signal, do not respond or comprehend the meaning of the signal. It is the property owner's responsibility to conduct fire drills and other training exercise to make people aware of fire alarm signals and instruct them on the proper reaction to alarm signals.
- In rare instances, the sounding of a warning device can cause temporary or permanent hearing loss.

A fire alarm system will not operate without any electrical power. If AC power fails, the system will operate from standby batteries only for a specified time and only if the batteries have been properly maintained and replaced regularly.

Equipment used in the system may not be technically compatible with the control. It is essential to use only equipment listed for service with your control panel.

Telephone lines needed to transmit alarm signals from a premise to a central monitoring station may be out of service or temporarily disabled. For added protection against telephone line failure, backup radio transmission systems are recommended.

The most common cause of fire alarm malfunction is inadequate maintenance. To keep the entire fire alarm system in excellent working order, ongoing maintenance is required per the manufacturer's recommendations, and UL and NFPA standards. At a minimum, the requirements of Chapter 7 of NFPA 72 shall be followed. Environments with large amounts of dust, dirt or high air velocity require more frequent maintenance. A maintenance agreement should be arranged through the local manufacturer's representative. Maintenance should be scheduled monthly or as required by National and/or local fire codes and should be performed by authorized professional fire alarm installers only. Adequate written records of all inspections should be kept.

Installation Precautions

WARNING - Several different sources of power can be connected to the fire alarm control panel. Disconnect all sources of power before servicing. Control unit and associated equipment may be damaged by removing and/or inserting cards, modules, or interconnecting cables while the unit is energized. Do not attempt to install, service, or operate this unit until this manual is read and understood.

CAUTION - *System Reacceptance Test after Software Changes.* To ensure proper system operation, this product must be tested in accordance with NFPA 72 Chapter 7 after any programming operation or change in site-specific software. Reacceptance testing is required after any change, addition or deletion of system components, or after any modification, repair or adjustment to system hardware or wiring.

All components, circuits, system operations, or software functions known to be affected by a change must be 100% tested. In addition, to ensure that other operations are not inadvertently affected, at least 10% of initiating devices that are not directly affected by the change, up to a maximum of 50 devices, must also be tested and proper system operation verified.

This system meets NFPA requirements for operation at 0-49° C/32-120° F and at a relative humidity of 85% RH (non-condensing) at 30° C/86° F. However, the useful life of the system's standby batteries and the electronic components may be adversely affected by extreme temperature ranges and humidity. Therefore, it is recommended that this system and all peripherals be installed in an environment with a nominal room temperature of 15-27° C/60-80° F.

Verify that wire sizes are adequate for all initiating and indicating device loops. Most devices cannot tolerate more than a 10% I.R. drop from the specified device voltage.

Adherence to the following will aid in problem-free installation with long-term reliability:

Like all solid state electronic devices, this system may operate erratically or can be damaged when subjected to lightning-induced transients. Although no system is completely immune from lightning transients and interferences, proper grounding will reduce susceptibility. *Overhead or outside aerial wiring is not recommended, due to an increased susceptibility to nearby lightning strikes.* Consult with the Technical Services Department if any problems are anticipated or encountered.

Disconnect AC power and batteries prior to removing or inserting circuit boards. Failure to do so can damage circuits.

Remove all electronic assemblies prior to any drilling, filing, reaming, or punching of the enclosure. When possible, make all cable entries from the sides or rear. Before making modifications, verify that they will not interfere with battery, transformer, and printed circuit board location.

Do not tighten screw terminals more than 9 in-lbs. Over-tightening may damage threads, resulting in reduced terminal contact pressure and difficulty with screw terminal removal.

Though designed to last many years, system components can fail at any time. This system contains static-sensitive components. Always ground yourself with a proper wrist strap before handling any circuits so that static charges are removed from the body. Use static-suppressive packaging to protect electronic assemblies removed from the unit.

Follow the instructions in the installation, operating, and programming manuals. These instructions must be followed to avoid damage to the control panel and associated equipment. FACP operation and reliability depend upon proper installation by authorized personnel.

FCC Warning

WARNING: This equipment generates, uses, and can radiate radio frequency energy and if not installed and used in accordance with the instruction manual, may cause interference to radio communications. It has been tested and found to comply with the limits for class A computing device pursuant to Subpart B of Part 15 of FCC Rules, which is designed to provide reasonable protection against such interference when operated in a commercial environment. Operation of this equipment in a residential area is likely to cause interference, in which case the user will be required to correct the interference at his own expense.

Canadian Requirements

This digital apparatus does not exceed the Class A limits for radiation noise emissions from digital apparatus set out in the Radio Interference Regulations of the Canadian Department of Communications.

Le présent appareil numérique n'émet pas de bruits radioélectriques dépassant les limites applicables aux appareils numériques de la classe A prescrites dans le Règlement sur le brouillage radioélectrique édicté par le ministère des Communications du Canada.

This page intentionally left blank

Table of Contents

1. Product Overview

General	9
Canadian Information	10
Related Documentation	10

2. Inventory

ACM-16ATF Series	11
Control Modules.....	11
ACM-16ATF	11
ACM-16ATCS4F (for use in Canada).....	11
ACM-16ATYF.....	11
Expander Modules.....	12
AEM-16ATF	12
ACM-32AF Series	13
Control Modules.....	13
ACM-32AF	13
Expander Modules.....	13
AEM-32AF	13
Cabinet & Panel Hardware	14
Surface-Mount Backboxes	14
ABS-1F	14
ABS-2F	14
ABS-1TF.....	14
Flush-mount Backboxes.....	15
ABF-1F	15
ABF-2F	15
ABF-4F	15
Semi Flush-mount Backboxes.....	16
ABF-1DF	16
ABF-2DF	16
Additional Hardware	17
ABM-1	17
AKS-1F	17

3. Design Considerations

Limits	19
Wire Runs	19
Wiring Specifications	19
Receive Only and Transmit/Receive	20
Electrical Ratings	21
Annunciator Power Requirements	21

4. Installation

Mounting the Backbox or Cabinet	23
Wiring and Connecting.....	23
Connect Wiring to Backbox or Cabinet.....	24
When the EIA-485 shield is not in conduit:	24
When the EIA-485 shield is in conduit:	24
EIA-485 Circuit	25
24 VDC Circuit.....	26
Installing Labels	27
Setting Rotary and DIP Switches.....	28
DIP Switch Settings	28
Mounting Annunciators and Expanders.....	29
Surface Mount Backbox (ABS Series)	29
Flush Mount Backbox (ABF Series).....	29
ABF-1F Backbox Only.....	29
ABF-2F and ABF-4F Backboxes Only.	30
Semi-Flush Mount Backbox (ABF-1DF/-2DF).....	31
Dress Panel (ADP-4F)	31
Wiring the Expander Connections	31
Two Position Backbox (-2 Series)	31
Four Position Backbox (-4 Series) or Cabinet	32
ACM-16 Series/AEM-16ATF	32
ACM-32AF/AEM-32AF	32
Supervising Devices.....	33
Main Power Supply Connections.....	33
Programming and Testing the Annunciators	33

5. LED and Switch Functions

ACM-16ATF	37
AEM-16ATF	39
ACM-32AF.....	40
AEM-32AF.....	41
UDACT-F and Annunciators	41

Appendix A: Sensiscan 200

Capabilities	43
Circuits:.....	43
System Controls:.....	43
Connecting EIA-485 Circuit.....	43
Providing Power to Annunciators	44
Program Mapping.....	45

Appendix B: Sensiscan 2000

Capabilities	47
Circuits:	47
System Controls:	47
Configuring for the Sensiscan 2000	47
Connecting the EIA-485 Circuit	48
Providing Power to Annunciators	49
Installing Modules in the System	50
Program Mapping	51

Appendix C: MS-9200

Capabilities	53
Connecting the EIA-485 Circuit	53
Providing Power to Annunciators	54
Program Mapping	55

Appendix D: MS-9600

Capabilities	57
Connecting the EIA-485 Circuit	57
Providing Power to Annunciators	58
Program Mapping	59

This Page Intentionally Left Blank

1. Product Overview

This manual provides instructions for connecting an ACM-16ATF series and ACM-32AF series annunciators to various Fire Alarm Control Panels. Each appendix contains instructions that are unique to a particular FACP.

General

This series provides Fire•Lite FACPs with up to 32 remote serially connected annunciators, each with a capacity of 64 points, for a total capacity of 2048 points. Expander modules are provided for each series.

The series provides an array of LEDs to indicate, at a remote location, the status of circuits within the system. Individual fire alarm control panels offer different methods of identifying annunciator points:

- **Sensiscan 200 and Sensiscan 2000** - Annunciator points directly follow the circuit arrangement of modules installed in the cabinet.
- **MS-9200 and MS-9600** - Annunciator points are programmable by group.

Common system functions such as signal silence, system reset, and local annunciation controls (local acknowledge and lamp test) are controlled through the annunciator's integral membrane push switches.

Communication between the control panel and the modules is accomplished over a power-limited, two-wire serial interface employing an EIA-485 communication standard. Power for the modules is provided via a separate power-limited power loop from the control panel which is inherently supervised by the annunciator module (loss of power results in an communication failure at the control panel). The module can also be powered from a power-limited and regulated remote power supply listed for fire-protective signaling use.

Canadian Information

The National Standard of Canada (CAN/ULC-S527) requires that a dedicated display employ yellow visual indicators to indicate the status of supervisory inputs. The Fire•Lite annunciators listed in this manual are intended to be used for Canadian Supervisory Service in conjunction with Fire•Lite Sensiscan 200, Sensiscan 2000, MS-9200 and MS-9600 control units. The ACM-16ATF/AEM-16ATF and ACM-32AF/AEM-32AF annunciators can not be employed for ULC Supervisory Service. See Canadian Requirements for Supervisory Signal in Fire•Lite Document 50057.

Annunciator control and expander modules in the “Y” series have been designed with yellow LEDs.

Related Documentation

Further details about products referenced in this document can be found in the manuals for the particular fire alarm control panels and components.

Product	Part Number
Sensiscan 200 Fire Alarm Control Panel Instruction Manual	15032
Sensiscan 2000 Fire Alarm Control Panel Instruction Manual	15017
MS-9200 Fire Alarm Control Panel Instruction Manual	51003
MS-9600 Fire Alarm Control Panel Instruction Manual	51335
UDACT-F Instruction Manual	50049
APS-6RF Auxiliary Power Supply Instruction Manual	50893
FCPS-24F Field Charger/Power Supply Instruction Manual	50079
Canadian Requirements for Supervisory Signal	50057
Fire•Lite Device Compatibility Document	15384

Table 1 Related Documentation

2. Inventory

ACM-16ATF Series

Control Modules

ACM-16ATF

Incorporates 16 red “point active” and 16 yellow “trouble” LEDs, 16 momentary touch-pad switches for controlling each point, a system trouble LED, an On-line/Power LED, and a local piezo sounder with a silence/acknowledge switch for audible indication of alarm and trouble conditions at each annunciator.

Height = 8-3/8" (21.27 cm)

Width = 4-3/8" (11.11 cm).

Note: In Canada this module must be used to annunciate the fire alarm input points/zones only.

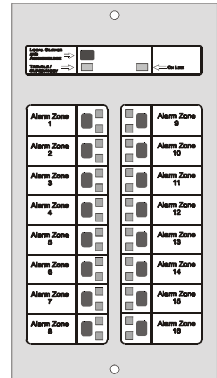

ACM-16ATCS4F (for use in Canada)

The ACM-16ATCS4 contains 12 red “point active”, four yellow “point active”, and 16 yellow “trouble” LEDs, 16 momentary touch-pad switches for controlling each point, a system trouble LED, an On-line/Power LED, and a local piezo sounder with a silence/acknowledge switch for audible indication of alarm and trouble conditions at each annunciator.

Note: In Canada this module must be used to annunciate supervisory and burglary signals from associated points/zones.

ACM-16ATYF

Same as the ACM-16ATF, except that all LEDs are yellow (yellow On/Alarm and yellow Trouble).

Note: In Canada this module must be used to annunciate supervisory and burglary signals from associated points/zones.

Note: In Canada the color red may only be used to indicate active alarm inputs. The color yellow may be used to indicate supervisory, burglary and trouble signals, and the color green may be used to indicate the presence of power, or an activated output.

Expander Modules

AEM-16ATF

Expands the ACM-16ATF Series by 16 system points. The unit is identical in size and in frontal appearance to the control module. One to three of these expander modules can be supported by a control module to a maximum of 64 system points.

Note: The AEM-16ATF Series cannot be used to expand the ACM-32AF. Expander LED colors need not match the control module LED colors for the expander to operate.

ACM-32AF Series

Control Modules

ACM-32AF

This control module contains 32 red “point active” LEDs, a system “trouble” LED, an On-line/Power LED, and a local piezo sounder with a silence/acknowledge switch for audible indication of alarm and trouble conditions at each annunciator.

Height = 8-3/8" (21.27 cm)

Width = 4-3/8" (11.11 cm).

Note: In Canada this module must be used to annunciate the fire alarm input points/zones only.

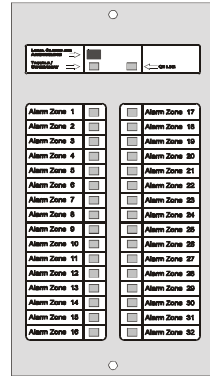

Expander Modules

AEM-32AF

Expands the ACM-32AF Series by 32 system points. This unit is identical in size and frontal appearance to the control module. One expander module can be supported by a control module providing a maximum of 64 points.

Note: The AEM-32AF cannot be used to expand the ACM-16ATF Series control modules.

Note: In Canada the color red may only be used to indicate active alarm inputs. The color yellow may be used to indicate supervisory, burglary and trouble signals, and the color green may be used to indicate the presence of power, or an activated output.

Cabinet & Panel Hardware

Surface-Mount Backboxes

ABS-1F

This surface mounted backbox provides for the remote mounting of a single ACM-16ATF Series or ACM-32AF Series annunciator in a surface-mount enclosure. Knockouts are provided for use with 1/2" conduit. The annunciator mounts directly to the box without a dress plate.

Height = 8-1/2" (21.59 cm)

Width = 4-1/2" (11.43 cm)

Depth = 1-3/8" (3.49 cm).

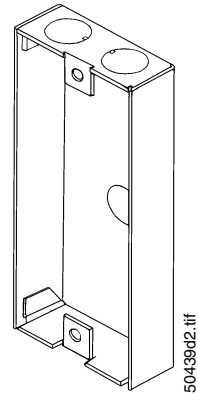

ABS-2F

This surface mounted backbox provides for the surface mounting of an annunciator-expander combination. Knockouts are provided for use with 1/2" conduit. The annunciator module mounts directly to the box without a dress plate.

Height = 8-1/2" (21.59 cm)

Width = 8-15/16" (22.7 cm)

Depth = 1-3/8" (3.49 cm).

Note: The ABS-1F and ABS-2F will not support the installation of the AKS-1 Annunciator Key Switch.

ABS-1TF

The ABS-1TF is a surface mounted backbox for mounting one ACS Series annunciator. This backbox has an increased depth that allows mounting of the AKS-1 Annunciator Key Switch.

Height = 9-15/16" (25.24 cm)

Width = 4-5/8" (11.75 cm)

Depth = 2-1/2" (6.35 cm).

Flush-mount Backboxes

ABF-1F

This flush mounted backbox provides for the remote mounting of a single annunciator module in a flush-mount enclosure. Knockouts are provided for use with 1/2" conduit. Includes a trim plate, mounting hardware, and an adhesive-backed annunciator label for the dress plate (15824).

Height = 9-15/16" (25.24 cm)

Width = 4-5/8" (11.75 cm)

Depth = 2-1/2" (6.35 cm).

Trim Plate dimensions -

11" (27.94 cm) x 6-1/4" (15.875 cm)

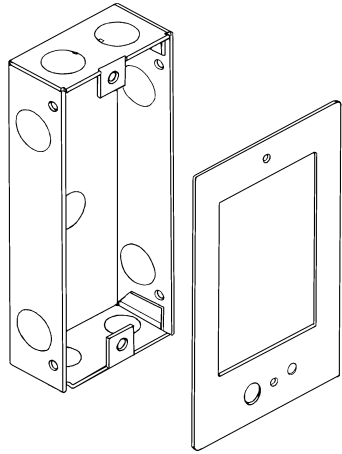

50439d3.tif

ABF-2F

This flush mounted backbox provides for flush mounting of one annunciator-expander combination. Includes a trim plate and an adhesive-backed annunciator label for the dress plate (15824).

Height = 8-1/2" (21.59 cm), Width = 8-15/16" (22.7 cm)

Depth = 1-3/8" (3.49 cm)

Trim Plate dimensions - 11" (27.94 cm) x 10-5/8" (26.99 cm)]

ABF-4F

This flush mounted backbox provides for the remote mounting of one to four annunciator modules. Knockouts are provided for use with 1/2" conduit. Includes a trim plate and an annunciator label.

Height = 9-15/16" (25.24 cm)

Width = 17-3/8" (44.13 cm)

Depth = 2-1/2" (6.35 cm).

Trim Plate dimensions -

11" (27.94 cm) x 19-3/8" (49.21 cm)

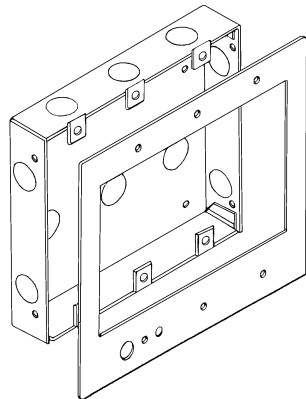

50439d1.tif

Semi Flush-mount Backboxes

ABF-1DF

This backbox mounts one Annunciator module and includes an attractive smoked glass door with keylock.

Box dimensions -

Height = 9-15/16" (25.24 cm)

Width = 4-5/8" (11.75 cm)

depth = 2-1/2" (6.35 cm).

Door dimensions -

Height = 10.713" (27.21 cm)

Width = 6" (15.24 cm)

Depth = 0.75" (1.9 cm).

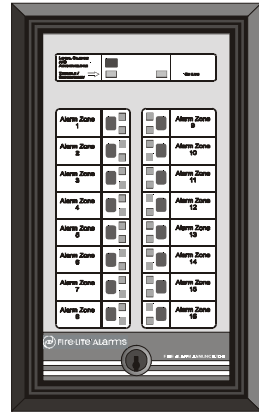

ABF-1DF.cdr

ABF-2DF

Same as ABF-1DF except that two modules can be mounted.

Box dimensions -

Height = 9-15/16" (25.24 cm)

Width = 9-3/16" (23.37 cm)

Depth = 2-1/2" (6.35 cm)

Door dimensions -

Height = 10.713" (27.21 cm)

Width = 10.375" (26.35 cm)

Depth = 0.75" (1.9 cm).

Additional Hardware

ABM-1

The Annunciator Blank Module is a two-sided dress plate identical in appearance to the front panel of the ACM-16ATF module on one side, and the front panel of the ACM-32AF module on the other side. The blank module covers unused module positions in the annunciator backbox or dress panel.

Height = 8-3/8" (21.27 cm), Width = 4-3/8" (11.11 cm).

AKS-1F

The Annunciator Key Switch provides access security for the control switches on the ACM-16ATF Series. The key switch kit includes a key and hardware for mounting to the trim plate of a flush-mount type annunciator enclosure. Also included is an adhesive-backed Annunciator Label for use with the key switch/dress plate assembly.

Note: The AKS-1F can only be employed with a flush-mount type backbox.

NOTES

3. Design Considerations

Limits

The standard Fire•Lite EIA-485 circuit can drive up to 32 annunciators or expanders. The number of annunciators that can engage in two-way communication is dependent on the number of addresses available with a given fire alarm control panel. The actual number of annunciator/expander modules that can be powered in a particular system depends on the current available from the control panel's power supply.

Note: Refer to the instruction manual of the particular Fire Alarm Control Panel for more details.

Wire Runs

Communication between the control panel and the annunciator occurs over a power-limited 2-wire EIA-485 serial interface. This communication is supervised by the fire alarm control panel. Each annunciator/expander module also requires a filtered 24 VDC power connection. This power circuit is inherently supervised; loss of power registers as a communication failure at the control panel.

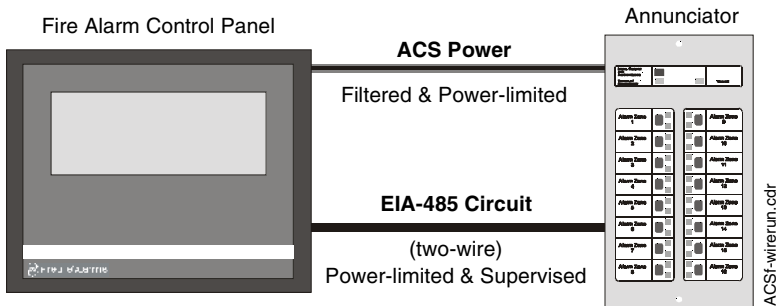

Figure 1 Wire Run Diagram

Wiring Specifications

The EIA-485 circuit cannot be T-Tapped; it must be wired in a continuous fashion. The maximum wiring distance is 6,000 feet at 16 AWG. The wiring size must be a 12 AWG to 18 AWG twisted shielded pair cable having a characteristic impedance of 120 ohms, +/- 20%. Limit the total wire resistance to 100 ohms on the EIA-485 circuit, and 10 ohms on the annunciator power circuit. Do not run cable adjacent to, or in the same conduit as, 120 volts AC service, "noisy" electrical circuits that are powering mechanical bells or horns, audio circuits above 25 volts RMS, motor control circuits, or SCR power circuits.

Receive Only and Transmit/Receive

For redundant annunciation of system points, annunciators can be configured as “Receive Only” annunciators. Receive Only annunciators must be set to the same address as the annunciators they duplicate. Receive Only annunciators intercept information being transmitted to a “Receive/Transmit” annunciator for duplication at an intermediate display location. When configured for Receive Only operation, they cannot be used to send information to the system, and as a result are not supervised by the control panel. They cannot perform remote functions such as Acknowledge, Silence, or Reset. Control switches on Receive Only annunciators can be used only for local functions, such as Lamp Test. Wiring to Receive Only annunciators may be supervised by installing the modules “upstream” of fully supervised, Receive/Transmit annunciators along the EIA-485 line.

Annunciators that are configured to serve as full function annunciators can both receive status information as well as transmit commands to the control panel. This allows the annunciator to remotely execute functions of the control panel in addition to displaying the status of the system.

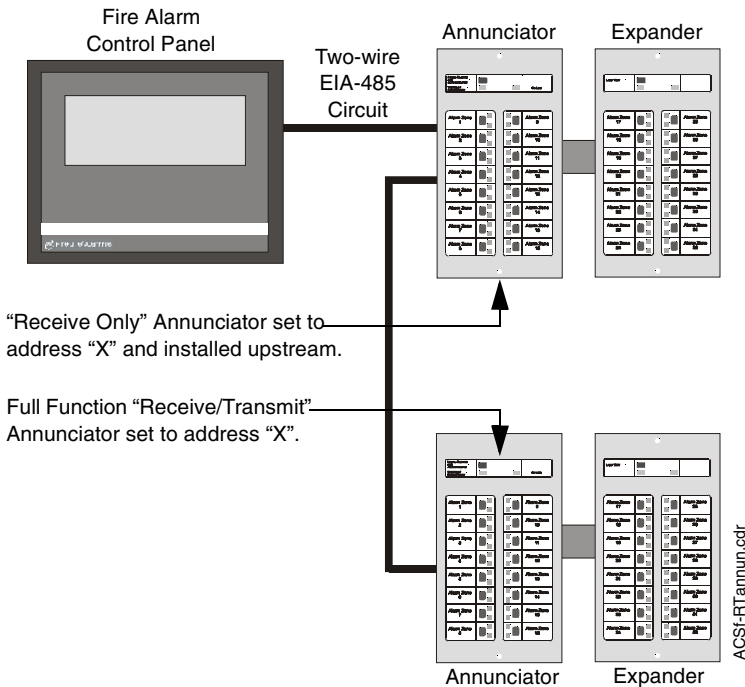

Figure 2 Receive/Transmit Annunciator Diagram

Electrical Ratings

Input Voltage: 24 VDC (must be filtered and power-limited).

Current Draw from 24 VDC Input:	Standby	Alarm
ACM-16ATF & ACM-32AF Series	0.040 amps	0.056 amps
AEM-16ATF & AEM-32AF Series	0.002 amps	0.018 amps

Data Communications Port: EIA-485 operating at 20 Kbps (must be power-limited).

Annunciator Power Requirements

Annunciators draw their power from the control panel and must be considered when calculating the primary and secondary power supply requirements for the system. Each annunciator module is accounted for in the power calculations outlined in the respective installation manual. However, if the current draw dedicated to the annunciators must be calculated as a separate figure, use the equations below:

Number of ACM modules	[]	X 0.040	= [] amps
Note: The 0.040 amps can be reduced to 0.030 for modules with Piezo Disable or Flash Inhibit modes selected.			
Number of AEM modules	[]	X 0.002	= [] amps
Total Annunciator Standby Current			= [] amps
Number of ACM and AEM modules assumed to be in alarm simultaneously	[]	X 0.016	= [] amps
Note: This entry assumes that all LEDs are lit simultaneously. When the alarm system specification permits, calculations can be based on a 10% alarm loading capacity. For 10% capacity, enter 10% of the total number of ACM and AEM modules multiplied by the number of remote annunciator locations, but do not enter less than one.			
Total Annunciator Alarm Current			= [] amps

Table 2 Calculation of Power Requirements

NOTES

4. Installation

This section provides detailed instructions for installing and wiring annunciator modules and expander modules.

Note: For wiring & programming details that are unique to a specific fire alarm control panel, refer to that panel's appendix in this manual, and to the panel's Instruction Manual.

Mounting the Backbox or Cabinet

Select appropriate knockout(s) on the enclosure for your wiring to run through and snap it out.

Fasten the cabinet or backbox to the wall.

Ground the enclosure to a solid metallic ground, such as a grounded cold water pipe.

Wiring and Connecting

Follow these guidelines when wiring and connecting the annunciator circuit(s):

- The EIA-485 circuit must be wired using a twisted-shielded pair cable having a Characteristic Impedance of 120 ohms, +/- 20%.
- Terminate the EIA-485 shield at the Fire Alarm Control Panel only.
- Do not run cable adjacent to, or in the same conduit as, 120-volt AC service, noisy electrical circuits that are powering mechanical bells or horns, audio circuits above 25 Vrms, motor control circuits, or SCR power circuits.
- All enclosures, including the FACP backbox, must be connected to earth ground.
- Never use the shield for grounding purposes.

Connect Wiring to Backbox or Cabinet

Pull all annunciator wiring into the enclosure and terminate as stated and illustrated below:

When the EIA-485 shield is not in conduit:

- Terminate the shield at the outside of the FACP backbox (*ground*).
- Do not allow the shield to enter or even touch the cabinet.
- Between annunciators, wire-nut multiple shields together *outside* of the respective enclosures.

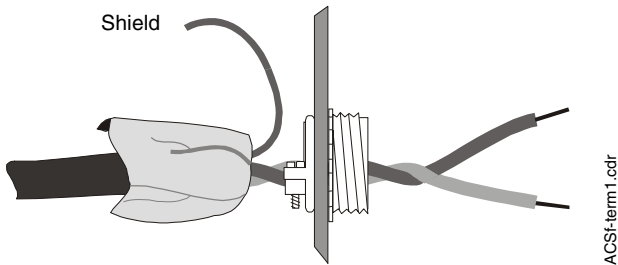

Figure 3 Terminating Wiring Not In Conduit

When the EIA-485 shield is in conduit:

- Connect it to system reference (*system common*).
- The shield can enter the cabinet, but must be insulated from the cabinet (no electrical contact).
- Between annunciators, wire-nut multiple shields together (which can be inside of the respective enclosure, but cannot contact the enclosure).

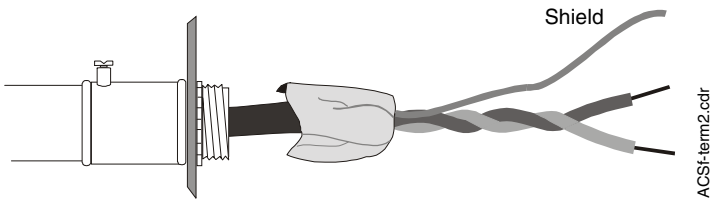
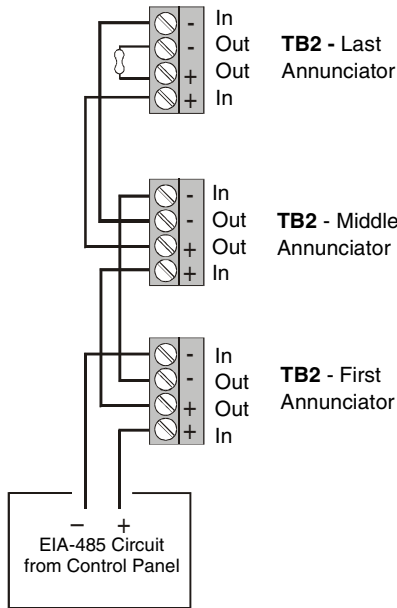

Figure 4 Terminating Wiring In Conduit

EIA-485 Circuit

Connect the EIA-485 annunciator circuit wiring to the removable terminal blocks as illustrated below.

- Do not “T-Tap” the power-limited EIA-485 circuit. It will not function properly.
- Leave the 120-ohm ELR (PN 71244) installed across the EIA-485 ‘Out’ terminals at the last annunciator on the circuit. Remove this resistor from all other annunciators.
- There is a maximum distance of 6000 feet between the panel and the last annunciator on the EIA-485 circuit.



ACS_eia.cdr

Figure 5 Connecting EIA-485 Wiring to Terminal Blocks

24 VDC Circuit



CAUTION: Power must be turned off when connecting the 24 VDC power to the annunciator to avoid damaging the equipment.

Connect the 24 VDC annunciator wiring to the removable terminal blocks as illustrated below:

- Power must be filtered, non-resettable, and power-limited.
- A Power Supervision Relay is not needed because the annunciator is inherently supervised by the control panel (loss of EIA-485 communication is registered at the control panel during loss of power to the annunciator).
- The power can be supplied by the FACP or a remote power supply listed for fire protective signaling use.
- Connect Earth Ground to a mounting screw on the backbox or cabinet.

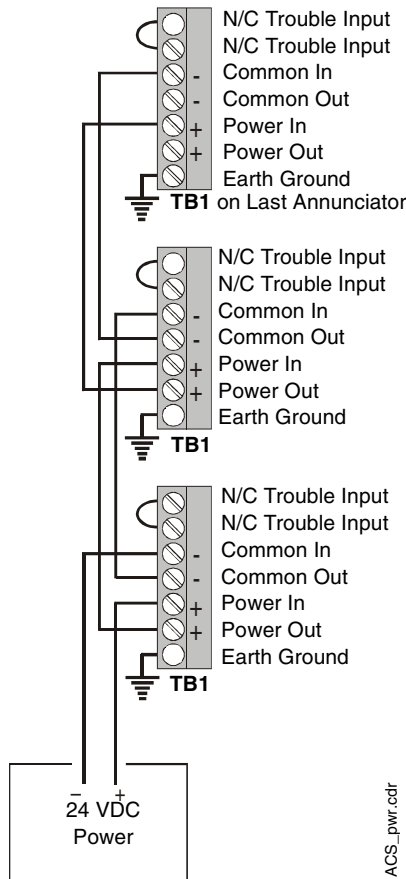

ACS_pwr.cdr

Figure 6 Connecting 24 VDC Wiring to Terminal Blocks

Installing Labels

Remove the center pages of this manual. If using the custom user display labels, type the appropriate information on the labels. Carefully cut out the labels and insert them into the annunciator or expander by slipping them into the label slots on the back side of the annunciator face plate. To ensure the best fit, cut directly along the dotted line surrounding each label.

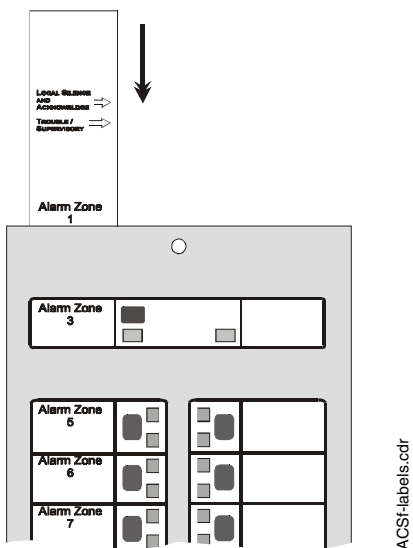

Figure 7 Installing Labels

Setting Rotary and DIP Switches

The Annunciator Address Rotary Switches and the DIP Switches must be set before the annunciator will operate properly. The rotary switches are set to the address of the annunciator. The DIP switches are set to determine how the annunciator operates. For further information see the appendix for the specific FACP.

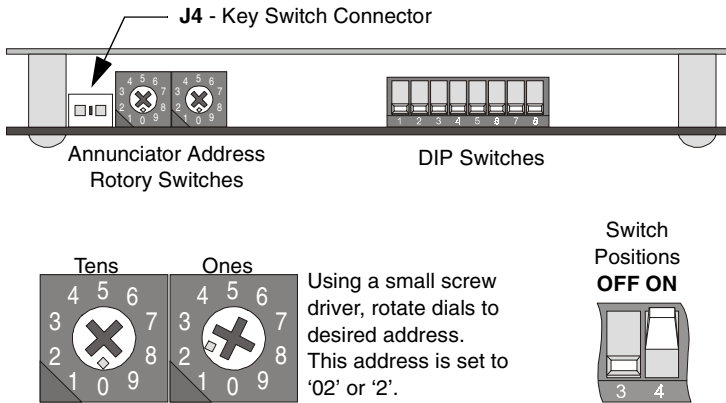

Figure 8 Setting Rotary and DIP Switches

DIP Switch Settings

1 - Not Used: This switch must be set "OFF"

2 - Expanders Installed: None = OFF; One = ON; Two = OFF; Three = ON

3 - Expanders Installed: None = OFF; One = OFF; Two = ON; Three = ON

4 - Eight-Point Shift: Set switch "ON" to switch the CPU functions out of the first eight annunciator points. This switch is intended for systems between 9 and 16 circuits and employing one ACM-16ATF module (with no expander) where annunciation of all circuits is desired.

5 - Receive Only: Set this switch "ON" for each annunciator that will provide the same information as another annunciator in a different location.

Note: When two or more annunciators hold the same address, all but one must be configured as "Receive Only" annunciators.

6 - Piezo Disable: Set this switch "ON" to disable the piezo from sounding for any event. (The piezo will also be disabled if Flash Inhibit is "ON".)

7 - Switch Inhibit: To disable the point control switches on the annunciator from executing system control functions, set this switch "ON". When inhibited, the switches will serve as local Lamp Test switches only. In addition, the Acknowledge/Lamp Test switch will function only in a local capacity, unrecognized by the control panel.

8 - Flash Inhibit: Set this switch "ON" to disable the flashing of LEDs associated with unacknowledged events. Flash Inhibit also disables the piezo from sounding.

Mounting Annunciators and Expanders

Set the address Rotary Switches and DIP Switches as outlined in "Setting Rotary and DIP Switches" on page 28 and the Appendix for specific fire alarm control panels.

Install labels in annunciator module and expander module(s) as detailed in "Installing Labels" on page 27.

Surface Mount Backbox (ABS Series)

1. Connect terminal blocks on circuit wiring in backbox to connectors on annunciator.
2. Align the mounting holes on the annunciator with the threaded tabs on the backbox and secure with the two screws provided. Tighten securely.

Flush Mount Backbox (ABF Series)

ABF-1F Backbox Only.

1. Remove the backing from the gummed label and affix to the trim plate as illustrated.

Note: If installing an Annunciator Key Switch (AKS-1F), use the label supplied with the kit instead of the label that ships with the annunciator. Holes in label will align with holes in trim plate.

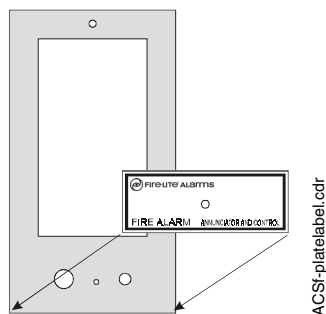

Figure 9 Applying the Label

2. Place the trim plate face down, with the threaded studs facing up. Position the annunciator over the threaded studs on the trim plate and secure with the two nuts and lock washers provided. Tighten securely.

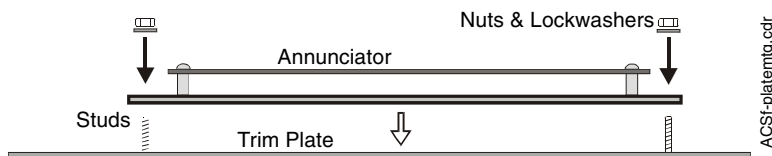

Figure 10 Assembling Trim Plate and Annunciator

3. If employing an AKS-1F Key Switch, mount it to the trim plate. Plug the switch leads to connector J4 on the annunciator.

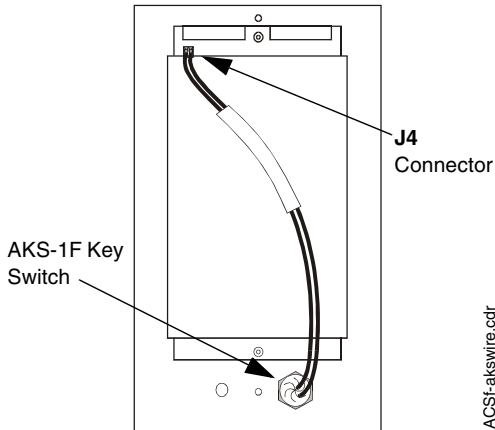

Figure 11 Annunciator Key Switch

4. Plug terminal blocks on circuit wiring in backbox to connectors on annunciator.
5. Align the mounting holes on the trim plate with the threaded tabs on the backbox and secure with the two screws provided. Tighten securely.

ABF-2F and ABF-4F Backboxes Only.

1. Remove the backing from the gummed label and affix to the trim plate as illustrated in Figure 9 on page 29.
2. Connect annunciator expander(s) as detailed in "Wiring the Expander Connections" on page 31.
3. Place the trim plate face down, with the threaded studs facing up. Position the annunciator and expander(s) over the threaded studs on the trim plate and secure each with the two nuts and lock washers provided (see Figure 10 on page 29). Tighten securely.
4. If employing a keyswitch, mount it to the trim plate. Plug the switch lead to Connector J4 on the annunciator (see Figure 11 on page 30).
5. Plug terminal blocks on circuit wiring in backbox to connectors on annunciator.
6. Align the mounting holes on the trim plate with the threaded tabs on the backbox and secure with the screws provided. Tighten securely.

Semi-Flush Mount Backbox (ABF-1DF/-2DF)

Annunciators and expanders are mounted in these backboxes the same way as they are mounted in the flush mounted type, except for the addition of the following:

Aligning the door with the trim plate, slide it down onto the pins of the trim plate. When positioned correctly, the door will open and close freely. Close and lock door.

Dress Panel (ADP-4F)

1. Connect annunciator expander(s) as detailed in "Wiring the Expander Connections" on page 31.
2. Place dress panel face down with the threaded studs facing up. Position the annunciator and expanders over the threaded studs on the dress panel and secure with the two nuts and lock washers provided, as illustrated below.

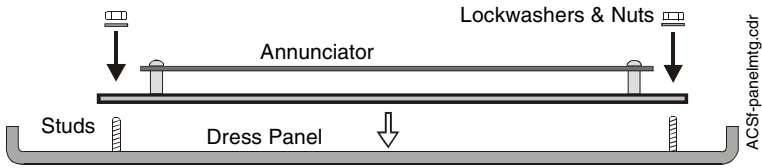

Figure 12 Installing Annunciator on ADP-4F Dress Panel

3. Align the annunciator/dress panel assembly with the holes into the cabinet backbox. Secure the assembly with the screws provided.
4. Plug terminal blocks on circuit wiring of FACP to connectors on annunciator.
5. Close dress panel and secure with quarter-turn screw.

Wiring the Expander Connections

Two Position Backbox (-2 Series)

If installing one ACM Series Annunciator and one AEM Series Expander in the same enclosure perform the following steps:

- Plug one end of an Expander Ribbon Cable into connector J2 on the annunciator module.
- Place the expander module in the second trim plate position.
- Connect the ribbon cable from the annunciator module to connector J3 on the expander module.

Four Position Backbox (-4 Series) or Cabinet

ACM-16 Series/AEM-16ATF

If installing one ACM-16 Series annunciator with three AEM-16ATF expanders on the same trim plate or dress panel, perform the following steps:

- Plug one end of an Expander Ribbon Cable into connector J2 on the annunciator module.
Place the expander module in the second position.
Connect the ribbon cable from the annunciator module to connector J3 on the expander module.
- Connect one end of a ribbon cable to connector J2 on the first expander module.
Place the second expander module in the third position.
Connect the other end of the expander ribbon from the first expander module to Connector J3 on the second expander module.
- Connect one end of a ribbon cable to Connector J2 on the second expander module.
Place the third expander module in the fourth position.
Connect the other end of the ribbon cable from the second expander module to Connector J3 on the third expander module.

ACM-32AF/AEM-32AF

If installing a second set of ACM-32AF/AEM-32AF annunciator/expander modules in the same dress panel or trim plate, repeat the following steps for installation of positions three and four:

- Plug terminal blocks on circuit wiring in backbox to connectors on the second annunciator set.
Note: A 120-ohm ELR must remain installed across the EIA-485 line at the last annunciator on the circuit.
- Place the annunciator module in position three.
- Plug one end of an Expander Ribbon Cable into connector J2 on the annunciator module.
- Place the expander module in the fourth position.
- Connect the ribbon cable from the annunciator module to connector J3 on the expander module.

Supervising Devices

The normally closed Trouble Input can be used for supervising local power sources or other devices. If employed, all changes in status (to and from the trouble state) will be sent to the control panel in the event of device failure or restoral.

If not used, a jumper must be installed across the terminals. Without this jumper, the control panel will register a trouble condition.

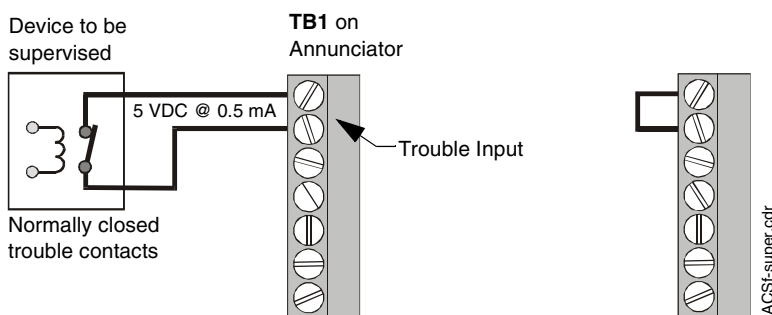

Figure 13 Connection of Supervising Devices

Main Power Supply Connections

The annunciator modules can be powered by an MS-9200 or MS-9600 internal power supply, an APS-6RF, FCPS-24F or an MPS-24 Series power supply. The power run to the annunciator need not contain a Power Supervision Relay because loss of power is inherently supervised through communication loss. For details about connecting the annunciator to a particular fire control panel, see the appropriate appendix in this manual.

Programming and Testing the Annunciators

After annunciator installation is complete, program the Fire Alarm Control Panel to accept the annunciators as explained in the programming section of the panel's manual.

After programming, fully test the system to ensure that each switch performs its intended function, that each LED lights, and that the annunciators can perform the functions outlined in "5. LED and Switch Functions" on page 37.



ACM-16ATF & AEM-16ATF Labels

Two labels are required for the ACM-16ATF or the AEM-16ATF, one for the left side and one for the right side of each module. Each label has a distinctive format. See "Installing Labels" on page 27 for more information on these labels.

Set A: Sensiscan 200 & Sensiscan 2000 - A label set that provides a label (#1) for system control functions & system status, and blank labels (#2 - #7) for one control module and three expander modules.

Set B: MS-9200 - A label set that provides a label (#1) for system control functions & system status. Use with Set A, Labels #2 - #8 to provide blank labels for one control module and three expander modules.

Set C: MS-9600 - A label set that provides a label (#1) for system control functions & system status. Use with Set A, Labels #2 - #8 to provide blank labels for one control module and three expander modules.

Set D: All Panels - This extra set of blank labels provides for customized information by the user for a control module.

To create custom slide-in labels for the ACM series annunciators, visit Fire•Lite's web site at 'www.firelite.com' and click on 'Label•Lite'.



Remove Center Pages for Slide-In Labels

ACM-32AF & AEM-32AF Labels

Two labels are required for the ACM-32AF or the AEM-32AF, one for the left side and one for the right side of each module. Each label has a distinctive format. See "Installing Labels" on page 27 for more information on these labels.

Set E: Sensiscan 200 & Sensiscan 2000 - A label set that provides a label (#1) for system status, and blank labels (#2 - #4) for one control module and one expander modules.

Set F: MS-9200 & MS-9600 - A label set that provides a label (#1) for system status, and blank labels (#2 - #4) for one control module and one expander modules.

Set G: All Panels - This extra set of blank labels provides for customized information by the user for a control module.

NOTES

5. LED and Switch Functions

ACM-16ATF

The following is a description of the various LEDs and switches located on the ACM-16ATF.

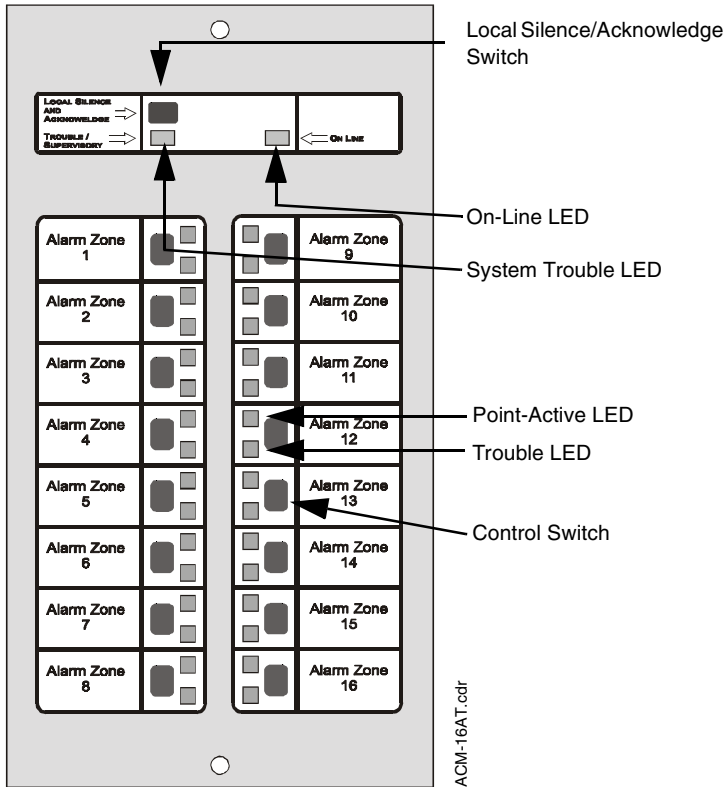

Figure 14 ACM Series LED & Switch Locations

Local Silence/Acknowledge Switch - This switch performs multiple functions:

- When pressed, it first lights all the LEDs (except the On-line LED) on the module and then each expander. Piezo sounds for as long as the switch is held down.
- It acknowledges all status changes for both the annunciator and the expanders. Flashing LEDs will latch on solid and the piezo will be silenced.

On-line LED - Flashes green during communication with the control panel.

System Trouble LED - Glows yellow for all trouble conditions in the system, including points or zones not mapped to the annunciator/expanders.

Point-Active LED - Flashes to indicate an active point; after being acknowledged it glows until reset.

Note: LED color varies by model number; see chart below.

Trouble LED - Flashes to indicate a trouble situation. After being acknowledged it glows until reset. If communication with control panel is broken, *all* trouble LEDs flash.

Note: LED color varies by model number; see chart below.

Control Switch - Functions as a local Lamp Test for the two LEDs dedicated to a point. Control switches can be used to execute such system functions as ACKNOWLEDGE, SIGNAL SILENCE, and SYSTEM RESET. Switches can also be used to control the status of various output circuits.

The table below describes the differences of the LED colors on the various modules.

	ACM-16ATF	ACM-16ATYF	ACM-16ATCS4F
Color of Point-active LED	Red	Yellow	12 Red, 4 Yellow
Color of Trouble LED	Yellow	Yellow	Yellow

Table 3 ACM Series LED Colors

AEM-16ATF

The following is a description of the various LEDs and switches located on the AEM-16ATF.

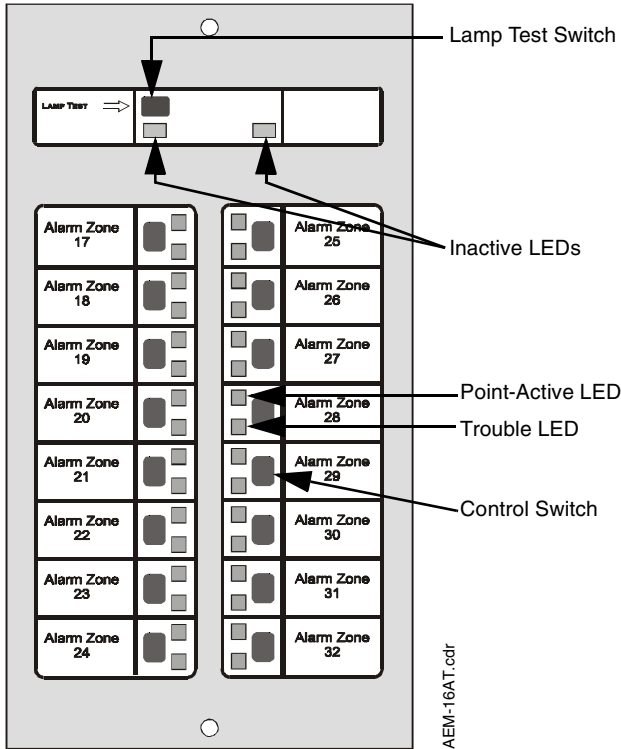

Figure 15 AEM-16ATF Series LED & Switch Locations

Lamp Test Switch - When pressed, it lights all the LEDs (except the On-line LED) on the expander and sounds the piezo for as long as the switch is held down.

Inactive LEDs - These two LEDs are not functional on expander modules.

Point-Active LED - Flashes to indicate an active point; after being acknowledged it glows until reset.

Trouble LED - Flashes to indicate a trouble situation. After being acknowledged it glows until reset. If communication with control panel is broken, *all* trouble LEDs flash.

Control Switch - Functions as a local Lamp Test for the two LEDs dedicated to this point. Control switches can be used to execute such system functions as ACKNOWLEDGE, SIGNAL SILENCE, and SYSTEM RESET. Switches can also be used to control the status of various output circuits.

ACM-32AF

The following is a description of the LEDs and the switch located on the ACM-32AF.

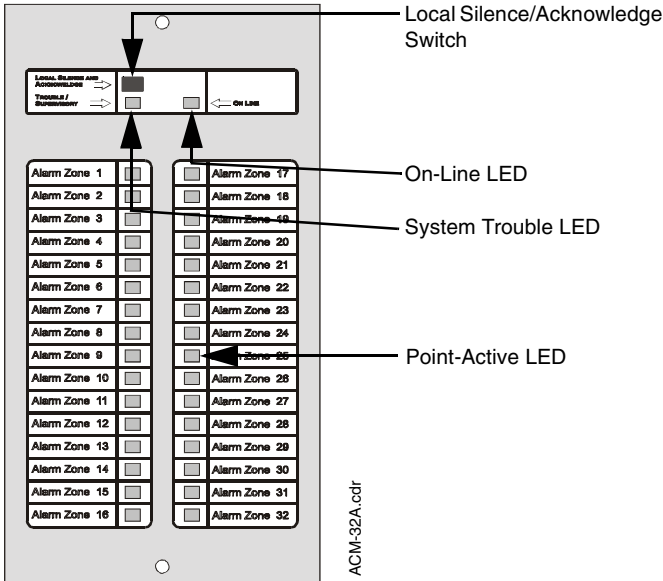

Figure 16 ACM-32AF LED & Switch Locations

Local Silence/Acknowledge Switch - This switch performs multiple functions:

- When pressed, it first lights all the LEDs (except the On-line LED) on the annunciator and then each expander. Piezo sounds for as long as the switch is held down.
- It acknowledges all status changes for both the annunciator and the expanders. Flashing LEDs will latch on solid and the piezo will be silenced.

On-line LED - Flashes green during communication with the control panel.

System Trouble LED - Glows yellow for all trouble conditions in the system, including points or zones not mapped to the annunciator/expanders. Flashes if communication with control panel is broken.

Point-Active LED - Flashes to indicate an active point; after being acknowledged it glows until reset.

Note: Loss of communication with the control panel is monitored & reported by the ACM-32AF. If connection between ACM-32AF & AEM-32AF fails, the ACM-32AF will show a trouble condition and the main control panel will show annunciator-point trouble.

AEM-32AF

The following is a description of the LEDs and the switch located on the AEM-32AF.

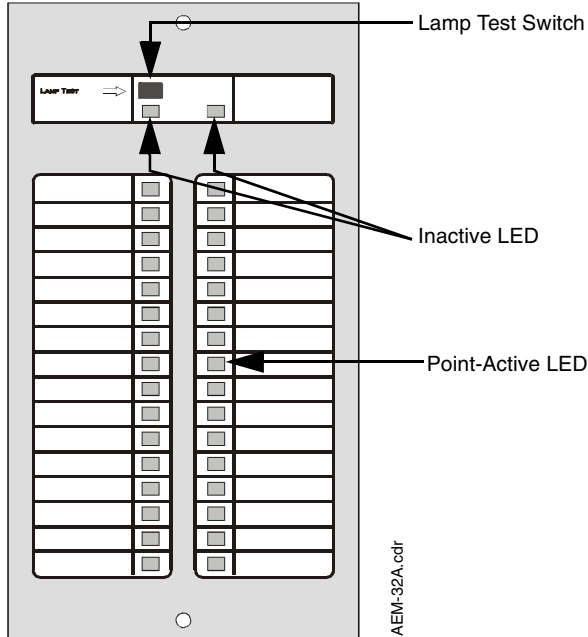

Figure 17 AEM-32AF LED & Switch Locations

Lamp Test Switch - When pressed, it lights all the LEDs (except the On-line LED) on the expander module and sounds the piezo for as long as the switch is held down.

Inactive LEDs - These two LEDs are not functional on expander modules.

Point-Active LED - Flashes to indicate an active point; after being acknowledged it glows until reset.

Note: Loss of communication with the control panel is monitored & reported by the ACM-32AF. If connection between ACM-32AF & AEM-32AF fails, the ACM-32AF will show a trouble condition and the main control panel will show annunciator-point trouble.

UDACT-F and Annunciators

The use of a UDACT-F (Universal Digital Alarm Communicator/Transmitter) and an annunciator module on the same control panel will alter the assignments of the trouble LEDs on annunciator points 3, 4, 5, 6, 7, and 8. Refer to the UDACT-F installation manual and the literature for the respective fire alarm control panel for further details.

NOTES

Appendix A: Sensiscan 200

Capabilities

When installed with a Sensiscan 200, the modules can annunciate the status of initiating and notification circuits, relays, and several system control functions. Up to 32 devices can be connected to the EIA-485 communications output, all addresses combined. Two way communications can occur with only one annunciator set to address “1”; other devices must be configured as “Receive Only”. Check battery calculation tables for power limitations. Each annunciator LED is automatically assigned to one and only one system point:

Circuits:

- IZ-4F, IZ-4AF, IZ-8F Initiating Device Circuits (alarm and trouble)
- IC-4F, ICE-4F, ICR-4LF Notification Appliance Circuits (activation and trouble)
- CR-4F, CRE-4F, CR-4LF Control relays (activation and trouble)
- TC-2F, TC-4F circuits (activation and trouble)

System Controls:

- Acknowledge
- Signal Silence
- System Reset
- Activate Notification Circuits 1 and 2, the Remote Signaling Municipal Tie circuit, and the Alarm Relay.

Connecting EIA-485 Circuit

Communication between the CPU and the annunciator module is accomplished over a two-wire EIA-485 serial interface.

- Power-limited and supervised.
- 6000 feet maximum distance (with 16 AWG wire) between the control panel and the furthest annunciator.
- Use twisted pair cable with a characteristic impedance of approximately 120 ohms.
- EIA-485 circuit rated 5.5 VDC max., 60 mA max.

This communication circuit is supervised by the Sensiscan 200. Loss of communication results in “System Trouble” and “Module Failure” indications at the CPU.

Note: “System Trouble” and “Module Failure” will occur if the normally closed supervisory path between Trouble Input Terminals of TB1 on the annunciator is opened (or the jumper has not been installed).

The EIA-485 circuit is connected between the EIA-485 Interface on the CPU and terminal TB2 on the annunciator.

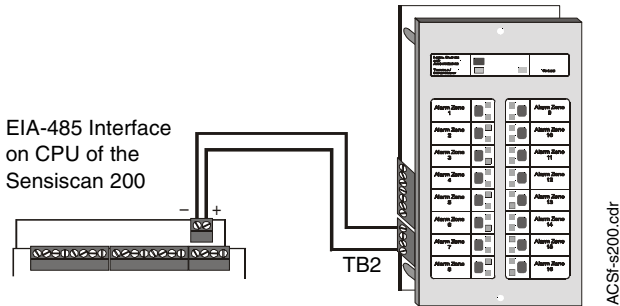

Figure 18 EIA-484 Circuit Connections - Sensiscan 200

Providing Power to Annunciators

Sensiscan 200 panels use the MPS-24BF Main Power Supply. No more than 200mA current can be drawn from these terminals in standby or alarm. This 24 VDC output is filtered, regulated, power-limited, and non-resettable.

The power run to the annunciator does not require a Power Supervision Relay because loss of power is inherently supervised through a communications loss.

Note: When not using the trouble input on annunciator or expander, jumper Trouble Input terminals of TB1 on annunciator together.

Connect the power run for the annunciator module to TB2 Terminals 3(+) and 4(-) as shown below.

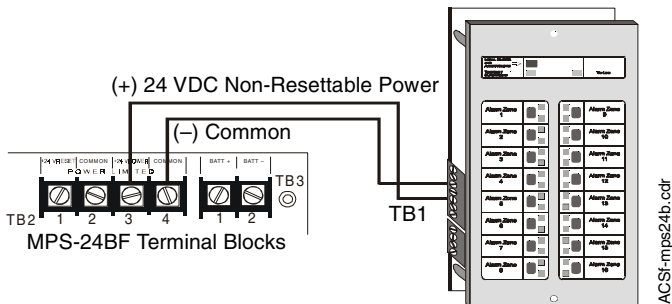

Figure 19 Power Connections - Sensiscan 200

Program Mapping

Annunciator points “track” or follow those system points they are programmed to annunciate; they do not latch. The table outlines the annunciation of various system circuits and functions.

Note: Control Switches marked “not used” will still function as local LAMP TEST or local ACKNOWLEDGE switches for their respective points.

Circuit Type	ACM-16ATF & AEM-16ATF		
	ACM-32AF AEM-32AF		
	Red LED	Yellow LED	Control Switch ¹
IZ-4F, IZ-4AF, IZ-8F circuit	Indicates alarm status of circuit ²	Indicates trouble status of circuit	Not used
IC-4F, ICE-4F, ICR-4LF circuit ³	Indicates Activation	Indicates trouble status of circuit	Controls Notification Circuit
CR-4F, CRE-4F, CR-4LF circuit ³	Indicates Activation	Indicates trouble status of relay	Controls Relays
TC-2F, TC-4F circuit	Indicates Activation	Indicates trouble status of relay	Remote Switch Functions
Annunciator Point #1 ⁴	Indicates System Alarm	Indicates System Trouble	ACKNOWLEDGE
Annunciator Point #2	Not used	Indicates that signals have been silenced	SIGNAL SILENCE
Annunciator Point #3	Not used	Not used	SYSTEM RESET
Annunciator Point #4	Not used	Indicates Supervisory condition	Not used
Annunciator Point #5	Indicates that Notification Circuit #1 has been activated	Indicates trouble status of circuit	Controls Notification Circuit #1
Annunciator Point #6	Indicates that Notification Circuit #2 has been activated	Indicates trouble status of circuit	Controls Notification Circuit #2
Annunciator Point #7	Indicates that Remote Signaling Municipal Tie has been activated	Indicates trouble status of circuit ⁵	Controls Remote Signaling Municipal Tie
Annunciator Point #8	Indicates that Alarm Relay has been activated	Indicates AC Fail	Controls Alarm Relay

1. These control switches are active only if: DIP Switch #5 (Receive Only) is 'OFF' and DIP Switch #7 (Switch Inhibit) is 'OFF'.
2. With Software P/N #S500R4.0 or higher installed in the Sensiscan 200, the manner in which the IZ-8Fcircuits programmed as supervisory are annunciated depends upon whether Mode 1 or Mode 2 is selected.
3. ICR-4LF and CR-4LF circuits are annunciated as points 41-44 when installed behind the middle module or points 49-52 when installed behind the right-hand side module.
4. If the Eight-Point Shift (DIP switch # 4) is set “ON,” the eight CPU functions will be shifted out of annunciator points 1 through 8. Those eight points will annunciate the first module.
5. Annunciator Point #7 yellow LED indicates Municipal Tie trouble if no UDACT-F is installed. It will annunciate Low Battery/Ground Fault if a UDACT-F is installed in the system.

Table 4 Annunciator Program Mapping - Sensiscan 200

NOTES

Appendix B: Sensiscan 2000

Capabilities

When installed with a Sensiscan 2000, the modules can annunciate the status of initiating and notification circuits, relays, and several system control functions. Each annunciator LED is automatically assigned to one and only one system point.

Note: To operate the annunciator module, the CPU must be Revision D or greater. The revision level of the CPU is marked on a label affixed to the upper board. Additionally, the system must be operating under CPU software with U4 ROM part number 73085 or higher.

Circuits:

- IZM-8F Initiating Device Circuits (alarm and trouble)
- ICM-4F / ICE-4F Notification Appliance Circuits (trouble)*
- CRM-4F / CRE-4F Control relays (trouble)*
- TCM-2F circuits (trouble)*
- TCM-4F circuits (trouble)*
- VCM-4F / DCM-4F circuits (trouble)*

*Indication of output circuit activation can be obtained by programming the CPU for "OUTPUT STATUS."

System Controls:

- Acknowledge
- Signal Silence
- System Reset
- Activate Notification Circuits 1 and 2, the Remote Signaling Municipal Tie circuit, and the Alarm Relay.

Configuring for the Sensiscan 2000

The annunciator can be set for addresses 1 or 2. The actual mapping arrangement for a respective annunciator module and its expanders depends on System annunciator programming. Refer to the Sensiscan 2000 Manual for a more detailed explanation.

Connecting the EIA-485 Circuit

Communication between the control panel and the annunciator module is accomplished over a two-wire EIA-485 serial interface.

- Power-limited and supervised.
- 6000 feet maximum distance (with 16 AWG wire) between the control panel and the furthest annunciator.
- Use twisted pair cable with a characteristic impedance of approximately 120 ohms.
- EIA-485 circuit rated 5.5 VDC max., 60 mA max.

This communication circuit is supervised by the Sensiscan 2000. Loss of communication results in “System Trouble” and “Module Failure” indications at the CPU.

Note: “System Trouble” and “Module Failure” will also occur if the normally closed supervisory path between TB1 Terminals on the annunciator is opened (or the jumper has not been installed).

The EIA-485 circuit is connected between the EIA-485 Interface on the CPU of the Sensiscan 2000 and terminal TB2 on the annunciator.

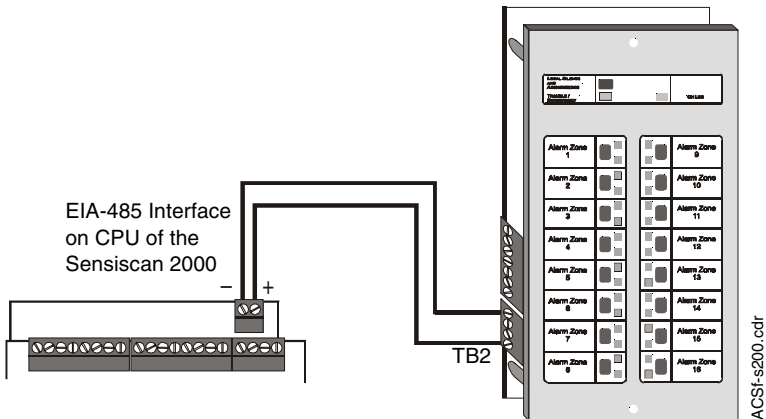

Figure 20 EIA-485 Circuit Connections - Sensiscan 2000

Providing Power to Annunciators

Sensiscan 2000 panels use the MPS-24AF or the MPS-24BF Main Power Supply. This 24 VDC output is filtered, regulated, power-limited, and non-resettable.

MPS-24AF - 3 A maximum current draw

MPS-24BF - 200 mA maximum current draw

The power run to the annunciator does not require a Power Supervision Relay because loss of power is inherently supervised through a communications loss.

Note: When not using the trouble input on annunciator or expander, jumper Trouble Input terminals of TB1 on annunciator together.

MPS-24AF Main Power Supply - Connect the power run for the annunciator module to the MPS-24AF TB3 Terminals 3(+) & 4(-), as shown below.

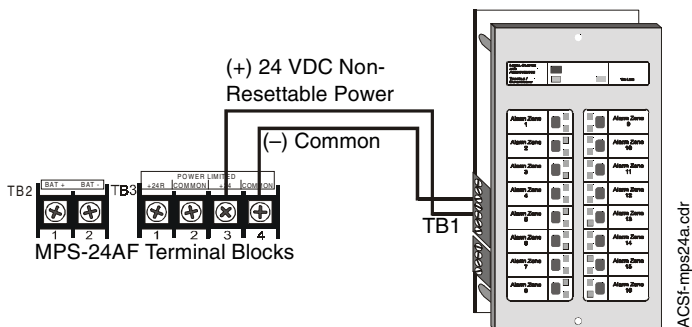

Figure 21 MPS-24AF Power Connections - Sensiscan 2000

MPS-24BF Main Power Supply - Connect the power run for the annunciator module to the MPS-24BF TB2 Terminals 3(+) & 4(-) as shown below.

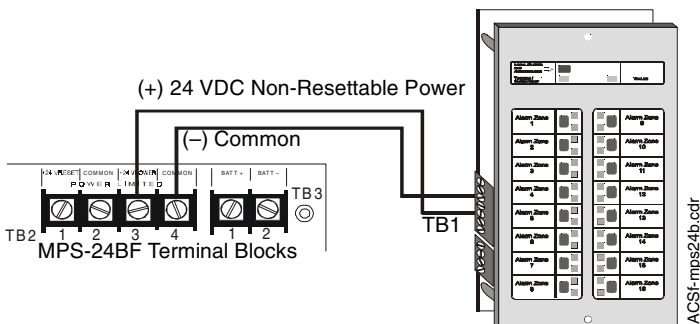

Figure 22 MPS-24BF Power Connections - Sensiscan 2000

Installing Modules in the System

The annunciator modules begin annunciation with the CPU and continue with the annunciation of circuits on the module installed directly after the CPU. To ensure full employment of annunciator points, mount system modules that require annunciation in the CPU row first, then in the second row, etc. Modules with circuits that need not be annunciated by the system should be installed further down in the cabinet.

Note: Without invoking the Eight-Point Shift, the first eight points would be dedicated to CPU functions, not circuits of the first module. Refer to "Setting Rotary and DIP Switches" on page 28.

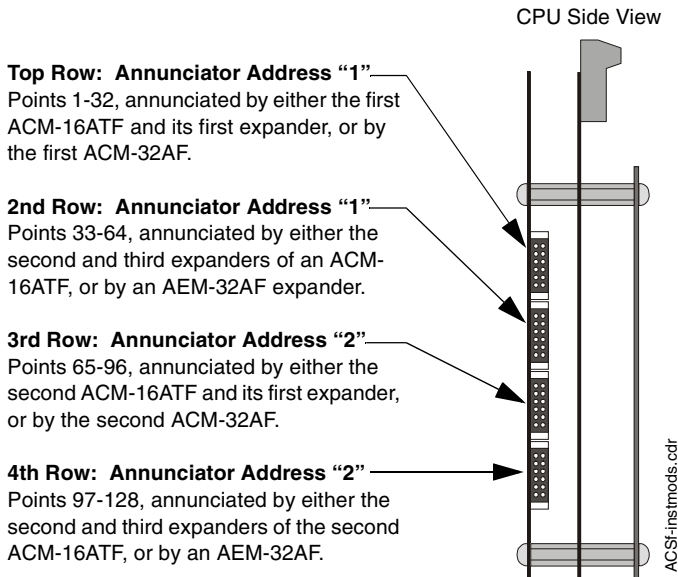

Figure 23 CPU Module Ribbon Cable Connections

Program Mapping

Annunciator points “track” or follow those system points they are programmed to annunciate; they do not latch. The table outlines the annunciation of various system circuits and functions.

Note: Control Switches marked “not used” will still function as local LAMP TEST or local ACKNOWLEDGE switches for their respective points.

Circuit Type	ACM-16ATF & AEM-16ATF		
	ACM-32AF AEM-32AF		
	Red LED	Yellow LED	Control Switch ¹
IzM-8F circuit	Indicates alarm status of circuit ²	Indicates trouble status of circuit	Not used
ICM-4F, ICE-4F circuit	Indicates Activation ³	Indicates trouble status of circuit	Controls Notification Circuit ⁴
CRM-4F, CRE-4F circuit	Indicates Activation ³	Indicates trouble status of relay	Controls Relays ⁴
TCM-2F, TCM-4F, VCM-4F, DCM-4F circuit	Indicates Activation ³	Indicates trouble status of relay	Remote Switch Functions ⁴
Annunciator Point #1 ⁵	Indicates System Alarm	Indicates System Trouble	ACKNOWLEDGE
Annunciator Point #2	Not used	Indicates that signals have been silenced	SIGNAL SILENCE
Annunciator Point #3	Not used	Not used	SYSTEM RESET
Annunciator Point #4	Not used	Indicates Supervisory condition	Not used
Annunciator Point #5	Indicates that Notification Circuit #1 has been activated	Indicates trouble status of circuit	Controls Notification Circuit #1
Annunciator Point #6	Indicates that Notification Circuit #2 has been activated	Indicates trouble status of circuit	Controls Notification Circuit #2
Annunciator Point #7	Indicates that Remote Signaling Municipal Tie has been activated	Indicates trouble status of circuit ⁶	Controls Remote Signaling Municipal Tie
Annunciator Point #8	Indicates that Alarm Relay has been activated	Indicates AC fail module/panel trouble	Controls Alarm Relay

1. These control switches are active only if: DIP Switch #5 (Receive Only) is ‘OFF’ and DIP Switch #7 (Switch Inhibit) is ‘OFF’.
2. With Software P/N #S500R4.0 or higher installed in the Sensiscan 2000, the manner in which the IZM-8F circuits programmed as supervisory are annunciated depends upon whether Mode 1 or Mode 2 is selected.
3. These status LEDs are active only when the system is programmed for “Output Status”.
4. These control switches require that the system be programmed for “Output Control”.
5. If the Eight-Point Shift (DIP switch # 4) is set “ON,” the eight CPU functions will be shifted from annunciator points 1 through 8 to points 57 through 64 (provided those points exist in the system).
6. Annunciator Point #7 yellow LED indicates Municipal Tie trouble if no UDACT-F is installed. It will annunciate Low Battery/Ground Fault if a UDACT-F is installed in the system.

Table 5 Annunciator Program Mapping - Sensiscan 2000

NOTES

Appendix C: MS-9200

Capabilities

The MS-9200 allows annunciators to be programmed by zone or by point. The EIA-485 serial interface will allow up to 32 annunciators, but two-way communications can occur with only one annunciator per address. The other devices must be configured as “Receive Only”.

When the panel is programmed by zone, annunciator address 1 is available, and the annunciator modules display the 56 software zones of the MS-9200. When the panel is programmed by point, 198 points are available. Annunciator addresses 1, 2, 3, and 4 can be used, but only address 1 is supervised.

The furthest annunciator can be 6000 feet from the fire alarm control panel (check power limitations).



CAUTION: Annunciators on the MS-9200 can not be used for manual control of Control modules, NACs, or relays (except for global Silence and Drill switches).

Connecting the EIA-485 Circuit

Communication between the MS-9200 and the annunciator modules is accomplished over a two-wire EIA-485 serial interface.

- Power-limited and supervised.
- 6000 feet maximum distance (with 16 AWG wire) between the control panel and the furthest annunciator.
- Use twisted pair cable with a characteristic impedance of approximately 120 ohms.
- EIA-485 circuit rated 5.5 VDC max., 60 mA max.

This communication circuit is supervised by the MS-9200. Loss of communication results in “System Trouble” and “Module Failure” indications at the CPU.

Note: “System Trouble” and “Module Failure” will also occur if the normally closed supervisory path between TB1 Terminals on the annunciator is opened (or the jumper has not been installed).

Continued on the next page...

The EIA-485 circuit is connected between the ACS Mode connector (TB5) on the main circuit board to terminal TB2 on the annunciator (see Figure 5 on page 25).

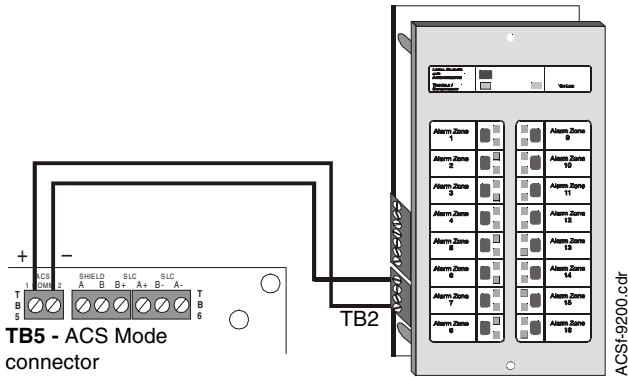

Figure 24 EIA-485 Circuit Connections - MS-9200

Providing Power to Annunciators

The MS-9200’s 24 VDC main power supply is contained on its main circuit board. No more than 300 mA current can be drawn from these terminals in standby or alarm. This 24 VDC output is filtered, regulated, power-limited, and non-resettable.

The power run to the annunciator need not require a Power Supervision Relay because loss of power is inherently supervised through a communication loss.

Note: When not using the trouble input on annunciator or expander, jumper Trouble Input terminals of TB1 on annunciator together.

The power circuit is connected between terminal TB4 on the MS-9200 and terminal TB1 on the annunciator (see Figure 6 on page 26) as shown below.

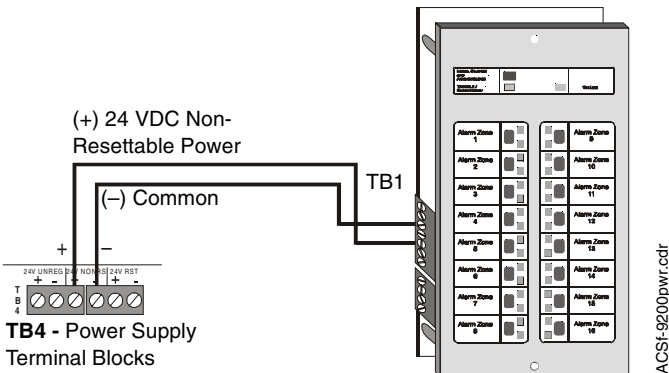

Figure 25 Power Supply Connections - MS-9200

Program Mapping

Annunciator points “track” or follow those system points they are programmed to annunciate; they do not latch. The table outlines the annunciation of system functions.

Note: Control Switches marked “No Function” will still function as local LAMP TEST or local ACKNOWLEDGE switches for their respective points.

Annunciator Point ¹	ACM-16ATF & AEM-16ATF		
	ACM-32AF AEM-32AF		
	Red LED	Yellow LED	Control Switch ²
Point #1	Indicates System Alarm	Indicates System Trouble	ACKNOWLEDGE
Point #2	Not used	Indicates Alarm Silenced	ALARM SILENCE
Point #3	Not used	Not used	SYSTEM RESET
Point #4	Not used	Not used	DRILL
Point #5	Not Used	Indicates Supervisory Condition ³	No Function
Point #6	Not Used	Indicates Maintenance Alert	No Function
Point #7	Not Used	Indicates Low Battery and NAC Trouble	No Function
Point #8	Not Used	Indicates AC Fail	No Function

1. If the Eight-Point Shift (DIP switch # 4) is set “ON,” the eight CPU functions will be shifted from annunciator points 1 through 8 to points 57 through 64 (provided those points exist in the system).
2. These control switches are active only if: DIP Switch #5 (Receive Only) is ‘OFF’ and DIP Switch #7 (Switch Inhibit) is ‘OFF’.
3. Supervisory Point lights its associated zone red LED and annunciator point #5 yellow LED.

Table 6 Annunciator Program Mapping - MS-9200

NOTES

Appendix D: MS-9600

Capabilities

The MS-9600 allows annunciators to be programmed by zone or by point. The EIA-485 serial interface will allow up to 32 annunciators, but two-way communications can occur with only one annunciator per address. The other devices must be configured as “Receive Only”.

When the panel is programmed by zone, annunciator address 1 is available, and the annunciator modules displays the 99 software zones of the MS-9600. When the panel is programmed by point, 318 points are available per SLC loop. Annunciator addresses 1, 2, 3, and 4 can be used, but only address 1 is supervised.

The furthest annunciator can be 6000 feet from the fire alarm control panel (check power limitations).



CAUTION: Annunciators on the MS-9600 can not be used for manual control of Control modules, NACs, or relays (except for global Silence and Drill switches).

Connecting the EIA-485 Circuit

Communication between the MS-9600 and the annunciator modules is accomplished over a two-wire EIA-485 serial interface.

- Power-limited and supervised.
- 6000 feet maximum distance (with 16 AWG wire) between the control panel and the furthest annunciator.
- Use twisted pair cable with a characteristic impedance of approximately 120 ohms.
- EIA-485 circuit rated 5.5 VDC max., 60 mA max.

This communication circuit is supervised by the MS-9600. Loss of communication results in “System Trouble” and “Module Failure” indications at the CPU.

Note: “System Trouble” and “Module Failure” will also occur if the normally closed supervisory path between TB1 Terminals on the annunciator is opened (or the jumper has not been installed).

Continued on the next page...

The EIA-485 circuit is connected between the ACS EIA-485 connector (TB6) on the main circuit board to terminal TB2 on the annunciator (see Figure 5 on page 25).

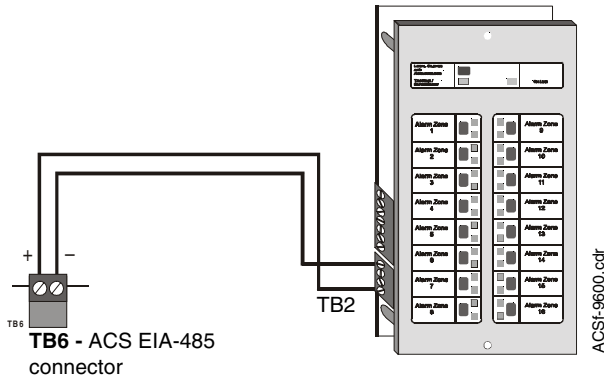

Figure 26 EIA-485 Circuit Connections - MS-9600

Providing Power to Annunciators

The MS-9600’s 24 VDC main power supply is contained on its main circuit board. No more than 3 Amps current can be drawn from these terminals in standby or alarm. This 24 VDC output is filtered, regulated, power-limited, and non-resettable.

The power run to the annunciator need not require a Power Supervision Relay because loss of power is inherently supervised through a communication loss.

Note: When not using the trouble input on annunciator or expander, jumper Trouble Input terminals of TB1 on annunciator together.

The power circuit is connected between terminal TB3 on the MS-9600 and terminal TB1 on the annunciator (see Figure 6 on page 26) as shown below.

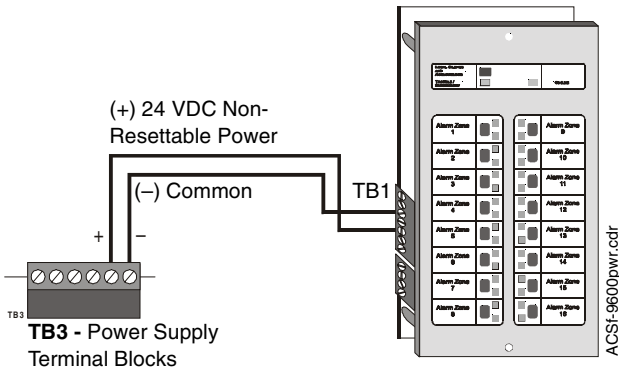

Figure 27 Power Supply Connections - MS-9600

Program Mapping

Annunciator points “track” or follow those system points they are programmed to annunciate; they do not latch. The table outlines the annunciation of system functions.

Note: Control Switches marked “No Function” will still function as local LAMP TEST or local ACKNOWLEDGE switches for their respective points.

Annunciator Point ¹	ACM-16ATF & AEM-16ATF		
	ACM-32AF AEM-32AF		
	Red LED	Yellow LED	Control Switch ²
Point #1	Indicates System Alarm	Indicates System Trouble	ACKNOWLEDGE
Point #2	Not used	Indicates Alarm Silenced	ALARM SILENCE
Point #3	Not used	Indicates Program Mode	SYSTEM RESET
Point #4	Not used	Indicates Supervisory Condition ³	DRILL
Point #5	Not Used	Indicates NAC Trouble	No Function
Point #6	Not Used	Indicates Walktest	No Function
Point #7	Not Used	Indicates Low Battery	No Function
Point #8	Not Used	Indicates AC Fail	No Function

1. If the Eight-Point Shift (DIP switch # 4) is set “ON,” the eight CPU functions will be shifted from annunciator points 1 through 8 to points 57 through 64 (provided those points exist in the system).
2. These control switches are active only if: DIP Switch #5 (Receive Only) is ‘OFF’ and DIP Switch #7 (Switch Inhibit) is ‘OFF’.
3. Supervisory Point lights its associated zone red LED and annunciator point #5 yellow LED.

Table 7 Annunciator Program Mapping - MS-9600

NOTES

Index

Numerics

120 volts AC 19
 120-ohm ELR 25, 32
 120-volt AC 23
 24 VDC 19, 21, 26, 44, 49
 24 VDC main power supply 54, 58

A

ACKNOWLEDGE 38, 39, 45, 51, 55, 59
 Acknowledge 20
 Acknowledge switch 28
 ACS EIA-485 connector 58
 ACS Mode connector 54
 active point 39, 40, 41
 Address Rotory Switches 28
 addresses available 19
 AKS-1F 29, 30
 Alarm Current 21
 annunciator address 50, 53, 57
 annunciator points 41, 45, 51, 55, 59
 APS-6RF 33

B

backbox 14, 15, 17, 23, 24, 29, 30, 31
 Blank Module 17

C

cable 19, 23, 43, 48, 53, 57
 calculations, power 21
 Canada, National Standard 10
 circuit wiring 29, 30, 32
 communication 19, 38, 39, 40, 41, 43, 53, 57
 communication circuit 44, 48, 53, 57
 conduit 14, 24

Control modules 53, 57
 Control relays 43, 47
 Control switch 20, 38, 39
 CPU 50
 current 19, 44, 54, 58
 current draw 21, 49
 custom user labels 27

D

dedicated display 10
 device failure or restoral 33
 DIP Switches 28, 29
 door 16
 dress panel 17, 31
 Drill switch 53, 57

E

Earth Ground 26
 EIA-485 9
 EIA-485 circuit 19, 23, 25, 44, 48, 54, 58
 EIA-485 serial interface 43, 48, 53, 57
 Eight-Point Shift 28, 50
 Expander Ribbon Cable 31, 32

F

FCPS-24F 33
 filtered 21, 44, 49, 54, 58
 filtered power 26
 fire protective signaling 26
 Flash Inhibit 28
 flush mounted 15, 31

G

glass door 16
 ground 23

Index

I

impedance 19, 23, 43, 48, 53, 57
Inactive LEDs 39, 41
Initiating Device Circuits 43, 47
Input Voltage 21
intermediate display 20

J

J2 31, 32
J3 31, 32
J4 28, 30
jumper 33, 44, 48, 53, 57

K

Key Switch 17, 29, 30
Key Switch Connector 28
keylock 16
knockout 23

L

label 15, 17, 30
label slots 27
labels 27, 29
LAMP TEST 45, 51, 55, 59
Lamp Test 20, 38, 39
Lamp Test Switch 39, 41
Lamp Test switches 28
LED colors 38
LEDs 9, 11, 13, 28, 37, 38, 39, 40, 41
local functions 20
local power sources 33

M

Main Power Supply 44, 49
manual control 53, 57
Mapping 45, 51, 55, 59
maximum distance 25, 43, 48, 53, 57
Module Failure 44, 48, 53, 57
mounting holes 29

mounting modules 50
MPS-24 Series 33
MPS-24AF 49
MPS-24BF 44, 49
multiple shields 24
Municipal Tie 43, 47

N

NACs 53, 57
National Standard of Canada 10
non-resettable 26, 44, 49, 54, 58
Notification Appliance Circuits 43, 47

O

On-line LED 37, 40

P

piezo 11, 13, 37, 39, 40, 41
Piezo Disable 28
point 47, 53, 57
point control switches 28
Point-Active LED 38, 39, 40, 41
points 38, 40
power calculations 21
power circuit 19
power run 44, 49
Power Supervision Relay 26, 33, 44, 49, 54, 58
power supply 9, 19, 21, 33
power-limited 9, 21, 26, 44, 49, 54, 58
primary power supply 21
programming 33

R

Receive Only 20, 28
redundant annunciation 20
regulated 44, 49, 54, 58
relays 43, 47, 53, 57
remote functions 20
remote mounting 14

remote power supply 26
 Reset 20
 resistance 19
 ribbon cable 31, 32
 Rotary Switches 28, 29

S

second set 32
 secondary power supply 21
 serial interface 9
 shield 23, 24
 SIGNAL SILENCE 38, 39
 signal silence 9
 Silence 20
 Silence switch 53, 57
 Silence/Acknowledge Switch 37, 40
 software zones 53, 57
 Standby Current 21
 status 33
 status changes 37, 40
 status information 20
 supervised 19, 20, 26, 44, 49, 53, 54, 57, 58
 supervising 33
 supervisory inputs 10
 surface mounting 14
 Switch Inhibit 28
 Switch, Key 17
 switches 28, 37
 system circuits and functions 45, 51
 system functions 9, 28, 38, 39, 43, 47, 55, 59
 system points 20, 45, 51, 55, 59
 SYSTEM RESET 38, 39
 system reset 9
 System Trouble 44, 48, 53, 57
 System Trouble LED 38, 40

T

TB1 26, 33, 44, 48, 53, 54, 57, 58
 TB2 25, 44, 48, 54, 58

terminal blocks 25, 26, 29, 30, 31, 32
 test the system 33
 threaded tabs 29, 30
 touch-pad switches 11
 transmit commands 20
 Transmit/Receive 20
 trim plate 15, 29, 30
 trouble condition 33, 38, 40
 Trouble Input 33
 Trouble LED 38, 39
 trouble LEDs 41
 trouble situation 39
 T-Tap 25
 T-Tapped 19

U

UDACT-F 41
 ULC Supervisory Service 10

W

wire 43, 48, 53, 57
 wire resistance 19
 wire-nut 24
 wiring 23, 24, 25
 wiring distance 19
 wiring size 19

Z

zone 53, 57
 zones 38, 40

Limited Warranty

The manufacturer warrants its products to be free from defects in materials and workmanship for eighteen (18) months from the date of manufacture, under normal use and service. Products are date-stamped at time of manufacture. The sole and exclusive obligation of the manufacturer is to repair or replace, at its option, free of charge for parts and labor, any part which is defective in materials or workmanship under normal use and service. For products not under the manufacturer's date-stamp control, the warranty is eighteen (18) months from date of original purchase by the manufacturer's distributor unless the installation instructions or catalog sets forth a shorter period, in which case the shorter period shall apply. This warranty is void if the product is altered, repaired, or serviced by anyone other than the manufacturer or its authorized distributors, or if there is a failure to maintain the products and systems in which they operate in a proper and workable manner. In case of defect, secure a Return Material Authorization form from our customer service department. Return product, transportation prepaid, to the manufacturer.

This writing constitutes the only warranty made by this manufacturer with respect to its products. The manufacturer does not represent that its products will prevent any loss by fire or otherwise, or that its products will in all cases provide the protection for which they are installed or intended. Buyer acknowledges that the manufacturer is not an insurer and assumes no risk for loss or damages or the cost of any inconvenience, transportation, damage, misuse, abuse, accident, or similar incident.

THE MANUFACTURER GIVES NO WARRANTY, EXPRESSED OR IMPLIED, OF MERCHANTABILITY, FITNESS FOR ANY PARTICULAR PURPOSE, OR OTHERWISE WHICH EXTEND BEYOND THE DESCRIPTION ON THE FACE HEREOF. UNDER NO CIRCUMSTANCES SHALL THE MANUFACTURER BE LIABLE FOR ANY LOSS OF OR DAMAGE TO PROPERTY, DIRECT, INCIDENTAL, OR CONSEQUENTIAL, ARISING OUT OF THE USE OF, OR INABILITY TO USE THE MANUFACTURER'S PRODUCTS. FURTHERMORE, THE MANUFACTURER SHALL NOT BE LIABLE FOR ANY PERSONAL INJURY OR DEATH WHICH MAY ARISE IN THE COURSE OF, OR AS A RESULT OF, PERSONAL, COMMERCIAL, OR INDUSTRIAL USE OF ITS PRODUCTS.

This warranty replaces all previous warranties and is the only warranty made by the manufacturer. No increase or alteration, written or verbal, of the obligation of this warranty is authorized.



World Headquarters
One Fire-Lite Place, Northford, CT 06472-1653 USA
203-484-7161 • Fax 203-484-7118
www.firelite.com

ISO 9001
CERTIFIED
ENGINEERING & MANUFACTURING