

Important: Retain these instructions

These instructions shall be used by trained service personnel only. If the equipment is used in a manner not specified by these instructions, the protection provided by the equipment may be impaired.



<https://partners.trendcontrols.com>

CONTENTS

1	Box Contents.....	1	4	Field Maintenance.....	11
2	Storing.....	1	5	Removing Controller from Din Rail.....	11
3	Installation.....	1	6	Disposal.....	11
			7	China Hazardous Substances Table.....	12

1 BOX CONTENTS

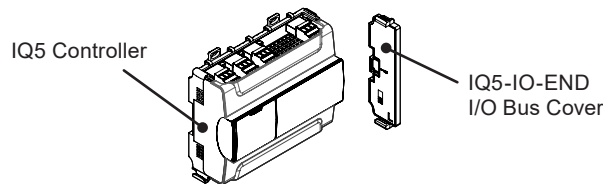

2 STORING

Note: For temperatures below 0°C (32°F) special care must be taken that there is no condensation on or within the unit.

3 INSTALLATION

Labels used on IQ5

	Caution, consult documentation		Caution, possibility of electric shock
POWER 24V	24 Vac/dc input power connector	RS485 1, 2, 3	RS-485 connector
IQ3/4 IO	IQ4, XCITE I/O bus connector		Ethernet connectors
	USB local engineering port		RS-485 Terminator switch
	USB (for future use)		Service button
RS485 1 2 3	RS485 port status indicators		
	Trend LAN status indicator		T1L IO bus status indicator

It is recommended that the installation should comply with the local electrical safety installation practices (e.g. HSE Memorandum of Guidance on Electricity at Work Regulations 1989, USA National Electric Code).

Any connected devices must be insulated from mains by reinforced insulation.

WARNING Removal of cover exposes dangerous voltages.

WARNING To reduce the risk of electrical shock or fire do not interconnect the output of different Class 2 circuits.

	Device status indicator		Service status indicator
--	-------------------------	--	--------------------------

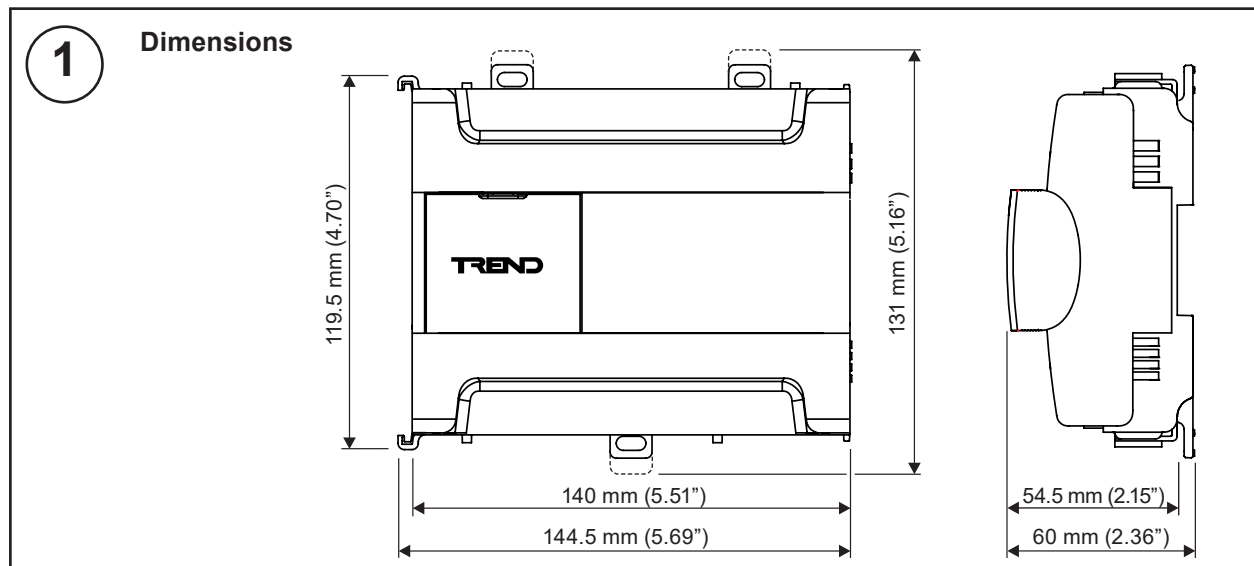

3 INSTALLATION (continued)

2 Mounting Requirements

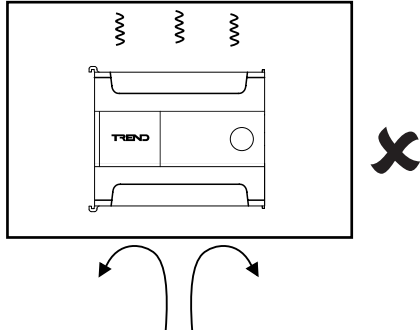

Protection IP20, NEMA1
 Altitude ≤4000 m (13124 ft)
 Pollution degree 2 (Only non-conducting pollution occurs)

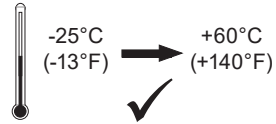

Note: For temperatures below 0°C (32°F) special care must be taken that there is no condensation on or within the unit.



The IQ5 should be installed in an enclosure or outside normal reach (e.g. in a plenum).

The unit is UL rated as UL60730-1 Automatic electrical controls for household and similar use.

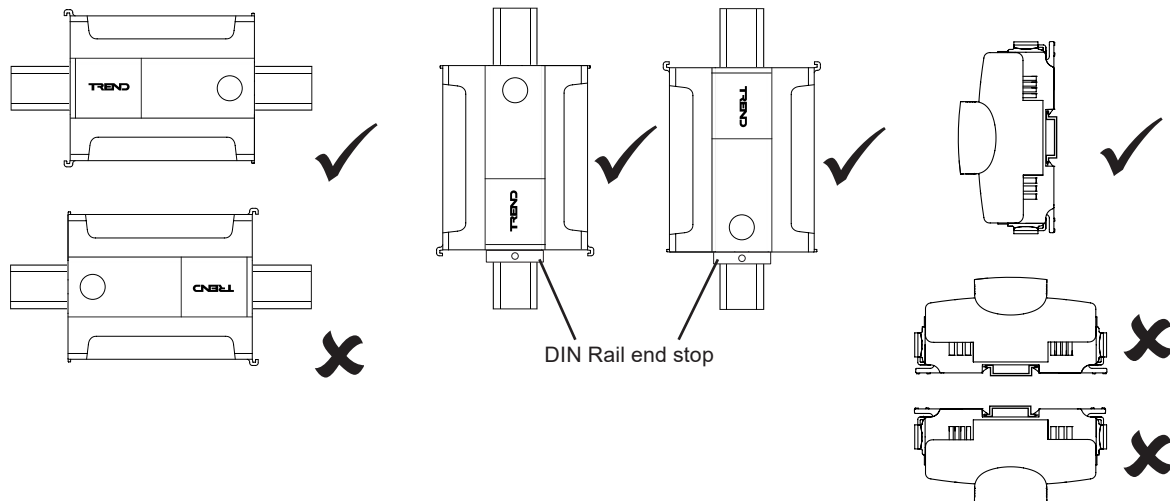
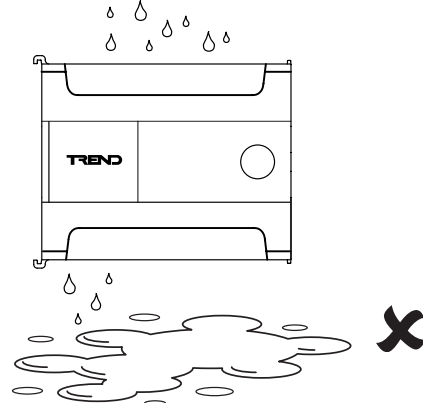
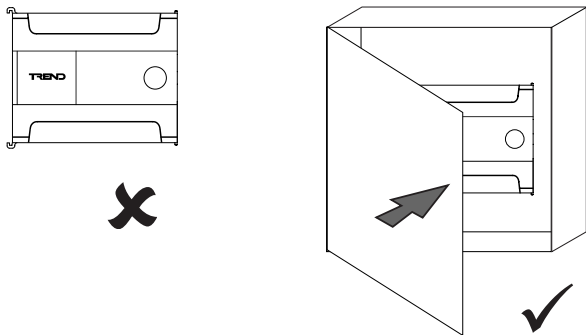

3 INSTALLATION (continued)

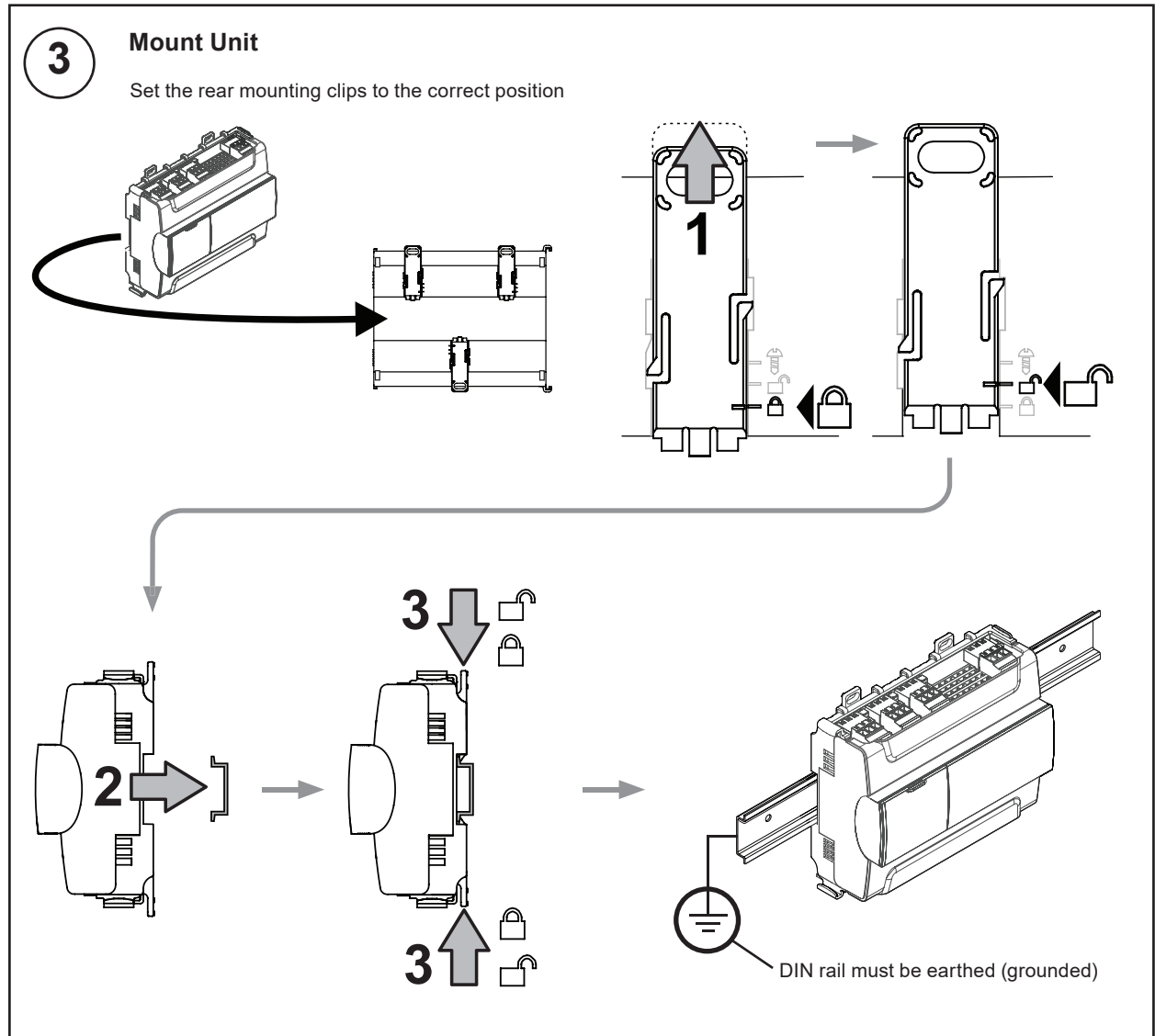

3 INSTALLATION (continued)

4 Connect Ethernet Network(s)

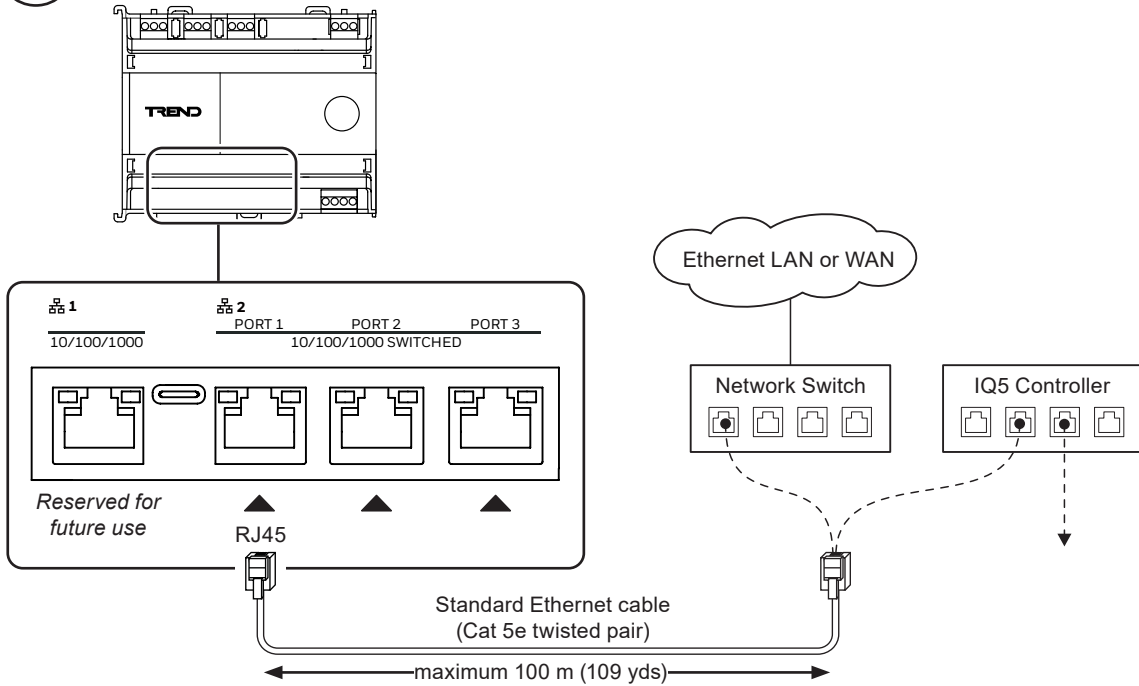

IQ5 Controller Network Example

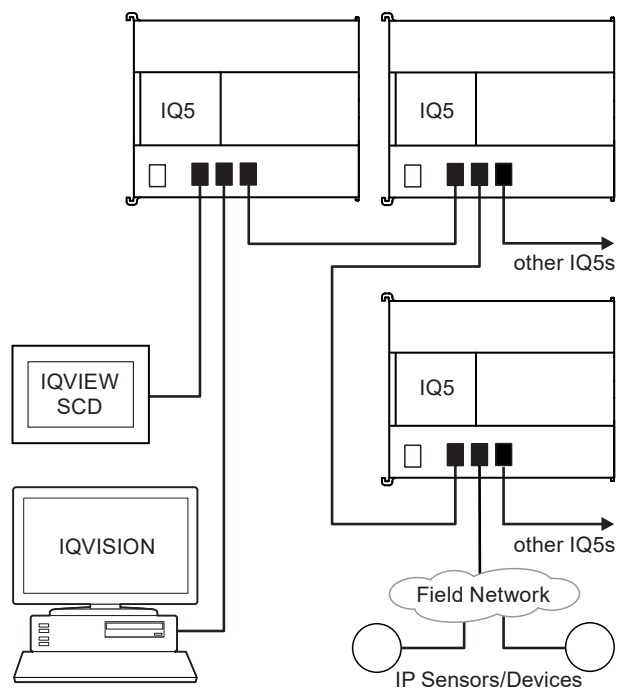

3 INSTALLATION (continued)

5 Unclip the Terminal Covers

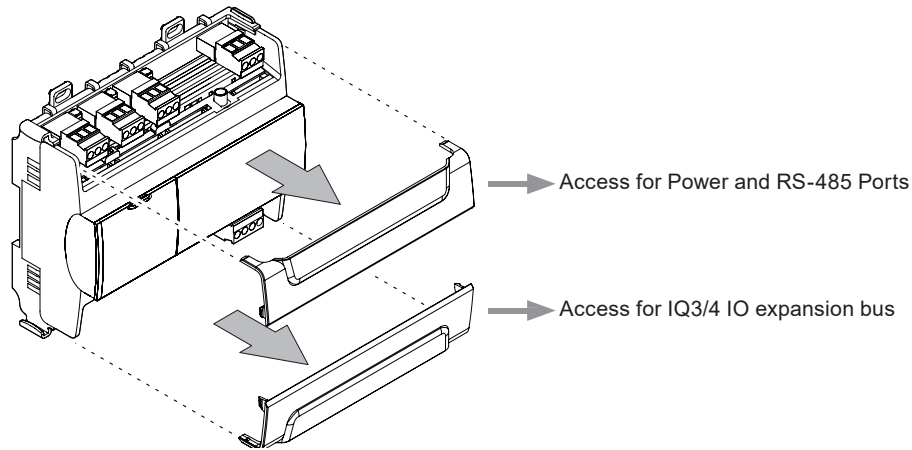

6 Make Connections - Overview

Plug-in connectors with screw terminals (as supplied)

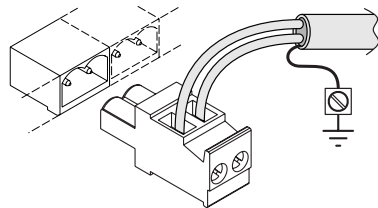

Optional connectors with push-fit terminals

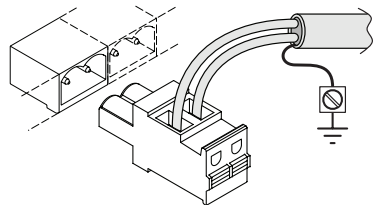

Terminal size: 0.5 to 2.5 mm² (20 to 14 AWG).
Terminal torque: 0.45 to 0.62 Nm (4 to 5.5 lb-in).

Note: For UL rating use 22 to 14 AWG - Cu only cable.

Connection Type	Go to step...
Power	7
RS-485 Ports	8
T1L Bus	9
IQ3/4 IO Bus	10

Note: It is recommended that wire ends are terminated using suitable ferrules, especially when using stranded wire with push-fit terminals.

3 INSTALLATION (continued)

7

Connect Power 

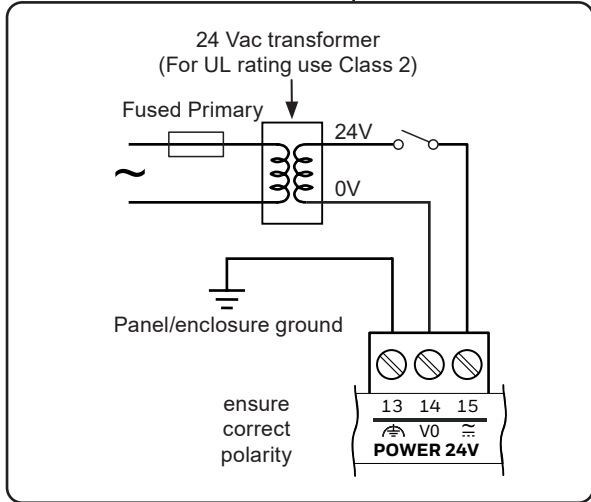
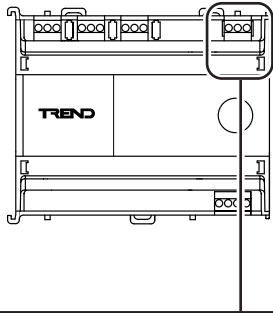

This equipment must be earthed (grounded).

Supply rating: 24 Vac $\pm 20\%$, 50/60 Hz, 34VA (1.42A);
24 Vdc $\pm 20\%$, 12.5W (0.52A).

If IO modules are to be powered from the controller's T1L bus, the above rating must be increased to take account of the additional load. Refer to the IQ5-IO Modules Data Sheet (TA201481) for details of module power consumption.

Power supply cable must have maximum operating temperature of 80°C or greater.

For UL rating the input power connections must be made using 18 AWG or larger wire rated at least 90°C (194°F).

The primary supply must include a fuse or circuit breaker appropriate for the transformer.

The 24 V supply must include a suitably rated switch in close proximity and be clearly marked as the disconnecting device for the unit.

Do not position the equipment so that the disconnecting device is difficult to operate.



3 INSTALLATION (continued)

8 Connect RS-485 Networks (if required)

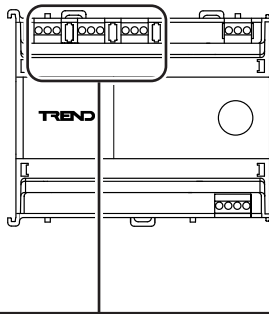

For use with Modbus, M-Bus, and/or XNC functionality. One port can also be used for an MSTP LAN of IQECOs.

Note: An appropriate converter will be required to enable connection to an RS-232 M-Bus network (e.g. using a PW60) or connection to an RS-485 4-wire network.

Where Modbus, M-Bus or XNC functionality is required this must be enabled by installing an INT licence. Where an MSTP LAN is required an NC licence must be installed and the controller operated in NC mode (see IQ5, IQ5-IO Installation Instructions - Configuration (TG201483)).

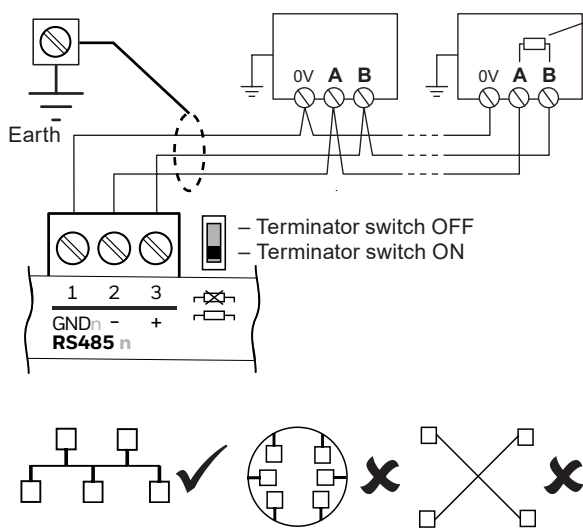

Termination: The bus must be terminated at each end with a resistor matched to the cable characteristic impedance (i.e. $\pm 1\%$, $\frac{1}{4}$ Watt, range 100 to 130 Ω). If the IQ5 is at one end of a 120 Ω cable, switch ON its built-in terminator, otherwise switch it OFF. Termination must be applied at the far end(s) of the cable.

Bias: The IQ5 does not need the bus to be biased as it has a fault tolerant transceiver and applies a small bias. Other devices on the bus may require biasing, in which case it should be provided at one point on the bus.

Protocol	Device Count	Cable Type	Max Length* metres (feet)
Modbus	32**	120 Ω twisted pair	900 (2953)
M-Bus	60	120 Ω twisted pair	1000 (3280)
MSTP	30	120 Ω twisted pair	1200 (4000)
XNC	32	depends on chosen application	

* dependent on cable specification and baud rate.
** up to 32 unit loads.

The GND/0V terminal **MUST** be connected on all devices.

It is not recommended to use the screen as the 0V connection.

Cable screening is recommended for reliable operation in electrically noisy environments. The cable screen should be connected to earth at one point.

Earthing (Grounding) & Isolation Requirements

If the IQ5 and other units on the bus are in the same cabinet using the same power supply, each device must have a good physical earth (ground) connection.

If the IQ5 and other units on the bus are in different cabinets or use different power supplies (e.g. different UPS units), the cabinets must be isolated from each other.

If the bus is likely to suffer from surge and grounding problems, surge protection should be added. The isolator should be connected to the earth (ground) of the nearest device, the 0V of the isolator and the surge protector should be connected together, and earth (ground) of the surge protector's exposed side (e.g. backbone bus) should be connected as directly as possible to the surge ground or earth bond. Ensure that terminators are fitted where indicated.

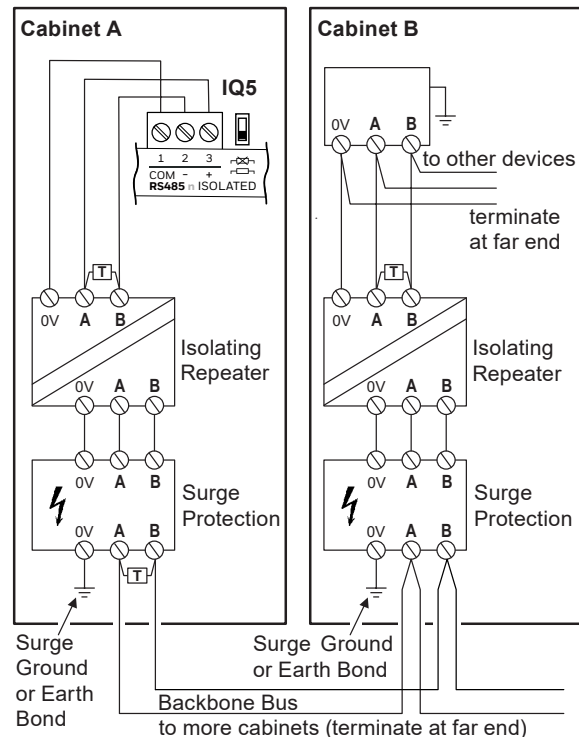

3 INSTALLATION (continued)

9 Install and Connect IQ5-IO Modules (T1L Bus) (if required)

Depending on the controller licence, up to 300 I/O channels are supported.

Remove I/O cover plate from IQ5 and retain for use on the last IQ5-IO module

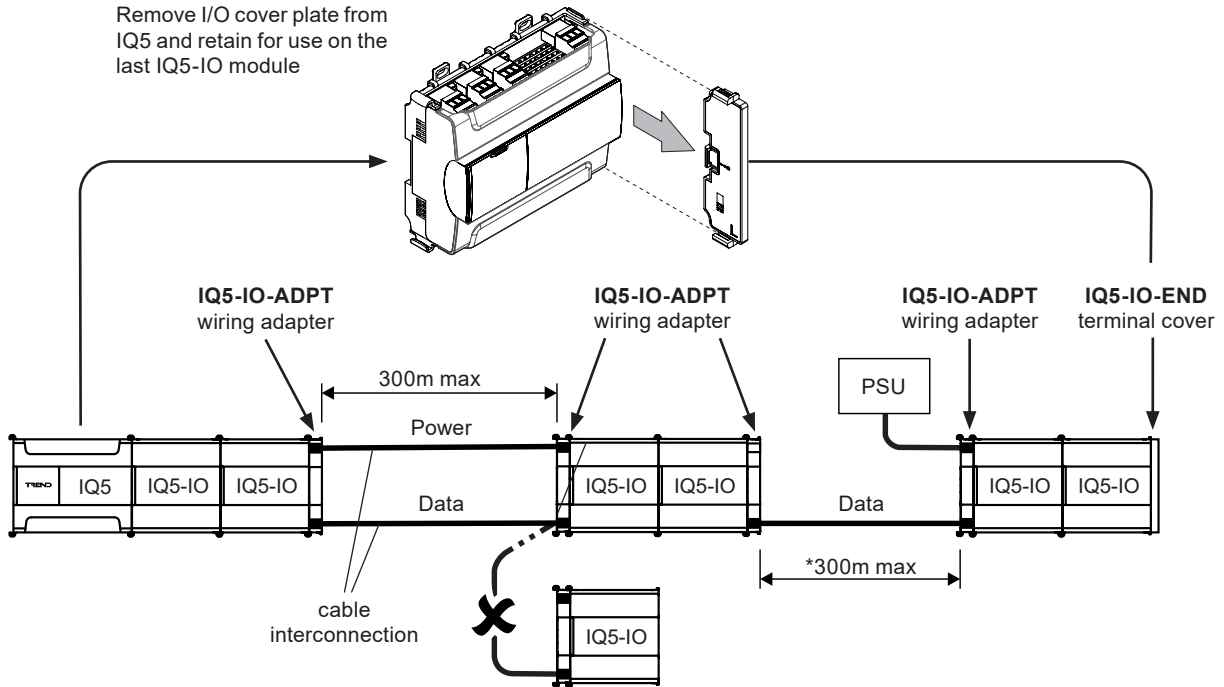

*Cable Length

Lon cable TP/1/0/16/HF/200 (Belden 8471) - up to 300 m (1000 ft) between modules.

MSTP cable TP/1/1/24/HF/305 or Belden equivalent 9841NH - up to 100 m (320 ft) between modules

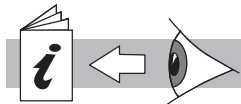

For full IO module installation details and power requirements, please refer to: IQ5-IO Installation Instructions - Mounting (TA201484)

3 INSTALLATION (continued)

10

Install and Connect IQ4/IO or XCITE/IO Modules (IQ3/4 IO Bus) (if required)

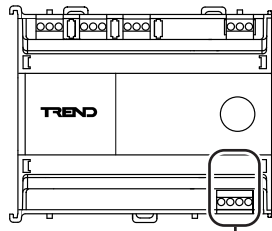

The IQ3/4 IO bus provides compatibility with I/O modules from the IQ4/IO and XCITE/IO ranges. Up to 192 I/O channels are supported on this bus.

Note: To use this bus it must be enabled by installing a CAN licence. See IQ5 Data Sheet (TA201480) for further details.

Note: No power is available via this connector. A separate 24 Vdc power supply must be provided. For all installations, if the bus voltage at an I/O module drops below 19.2 V at full load, install another power supply at that module.

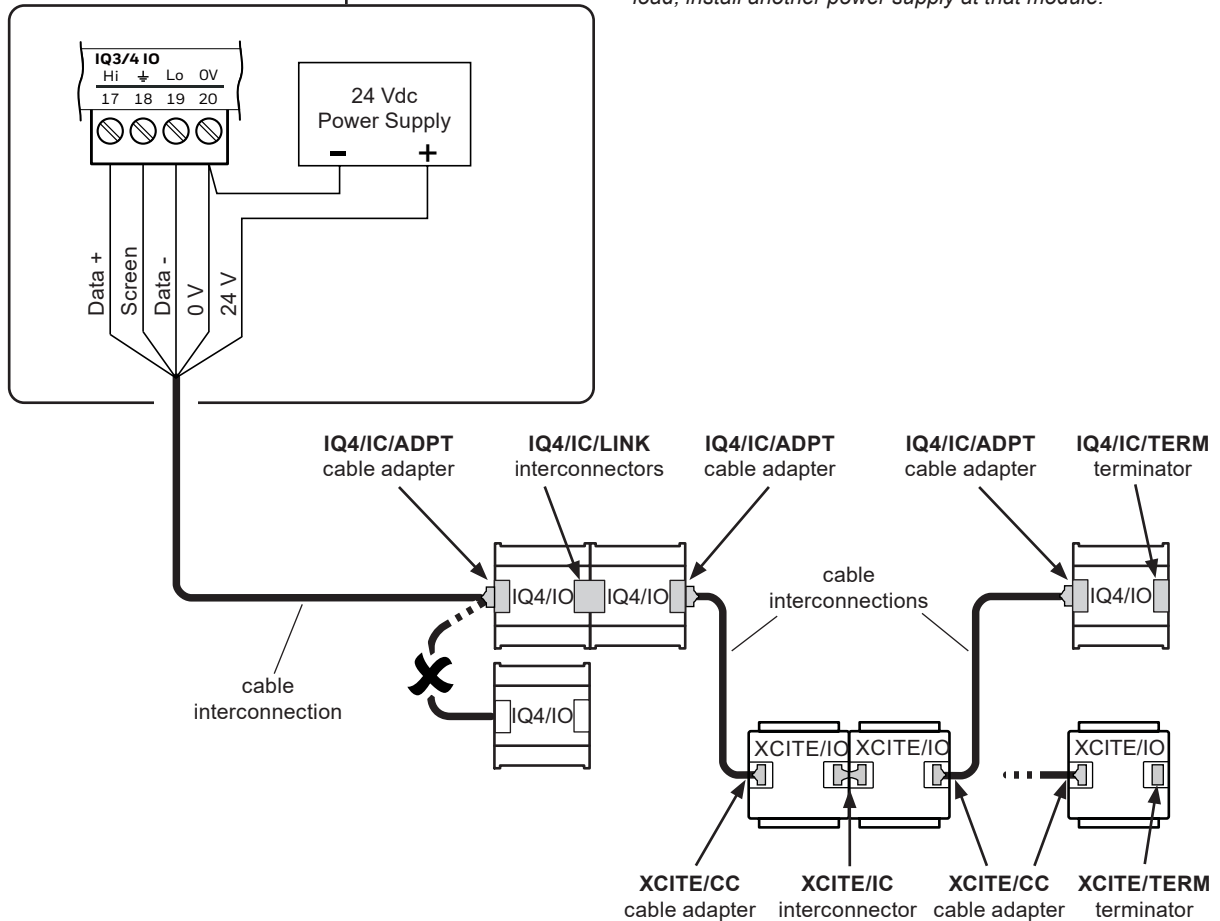

Controller and IO Module Configuration	Maximum I/O bus length depending on cable type (excluding rigid interconnectors)		Maximum No. of Modules
	Belden 3084A	Belden 7895A	
IQ5 controller with IQ4/IO modules only	total bus length up to 100 m (109 yards) or total bus length up to 300 m (328 yards) if IQ4/IO modules are within 100m (109 yards) of a power supply	total bus length up to 300 m (328 yards)	30
IQ5 controller with IQ4/IO modules and/or XCITE/IO modules	total bus length up to 30 m (33 yards) <i>Note: Maximum 10 m (11 yards) for certain system configurations - for details check the XCITE/IO Modules Data Sheet (TA201352) and XCITE/IO Installation Instructions - Mounting (TG200627).</i>		15

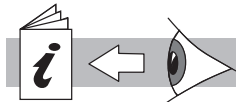

IQ4/IO Installation Instructions - Mounting (TG201342)
XCITE/IO Installation Instructions - Mounting (TG200627)

3 INSTALLATION (continued)

11

Refit Terminal Covers

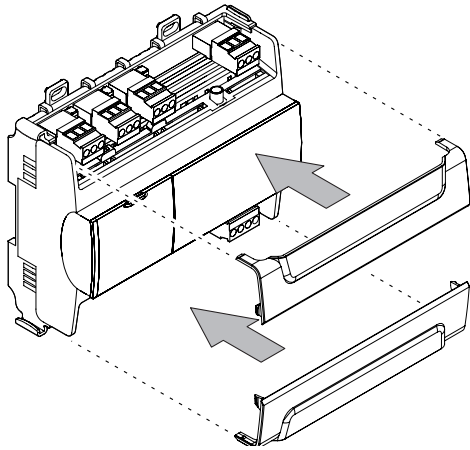

Note: Spare covers are available to order (e.g. IQ5-TCVR-140-10)

12

Fit IO Terminal Cover

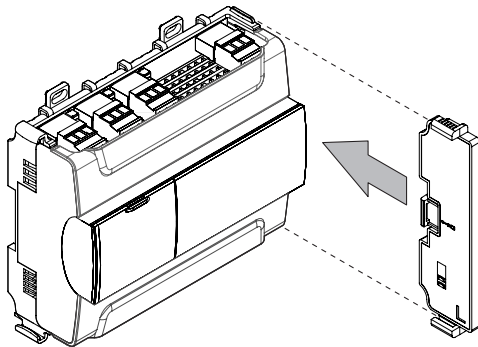

Note: Spare covers are available to order (e.g. IQ5-IO-END-10)

13

Close Panel / Enclosure

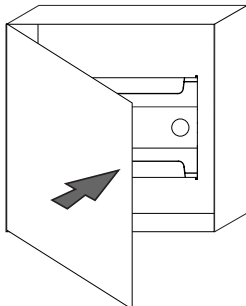

14

Configure IQ5 Controller and I/O Modules

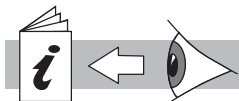

IQ5, IQ5-IO Installation Instructions - Configuring (TG201483)
IQ4/IO/.. Installation Instructions - Configuring (TG201343)
XCITE/IO/.. Installation Instructions - Configuring (TG201161)

4 FIELD MAINTENANCE

The IQ5 require no routine maintenance.



WARNING: Contains no serviceable parts. Do not attempt to open the unit. Failure to comply may cause damage to the unit.

5 REMOVING CONTROLLER FROM DIN RAIL

1 Isolate Power (including IO supplies)

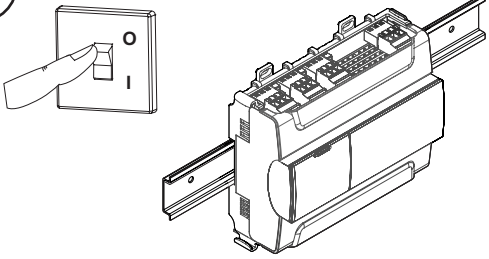

 **Warning:** Hazardous voltages may be present on I/O terminals. Isolate before touching.

2 Remove Terminal Covers

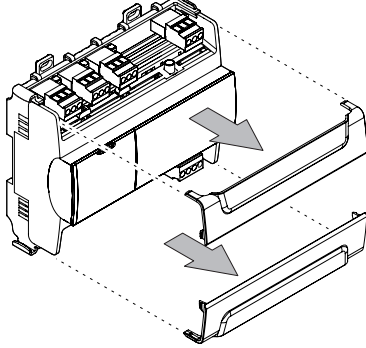

3 Unplug Wired I/O Connectors

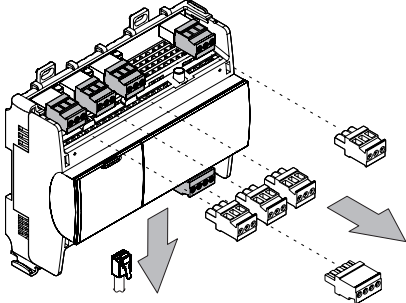

4 Unclip Module from DIN Rail

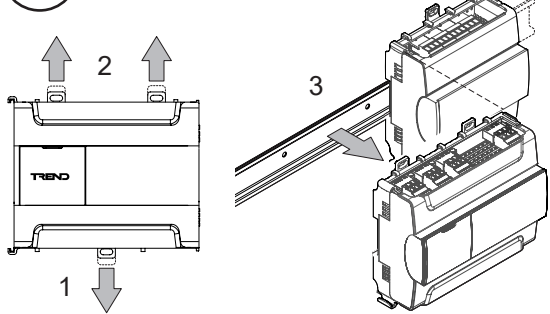

6 DISPOSAL



WEEE Directive:
At the end of their useful life the packaging and product should be disposed of by a suitable recycling centre.
Do not dispose of with normal household waste.
Do not burn.

7 CHINA HAZARDOUS SUBSTANCES TABLE

部件名称 Component Name	有害物质 Hazardous Substances					
	铅 (Pb) Lead (Pb)	汞 (Hg) Mercury (Hg)	镉 (Cd) Cadmium (Cd)	六价铬 (Cr6+) Chromium VI Compounds (Cr6+)	多溴联苯 (PBB) Polybrominated Biphenyls (PBB)	多溴二苯醚 (PBDE) Polybrominated Diphenyl Ethers (PBDE)
电缆 Cables	X	O	X	O	O	O
印刷电路板总成 PCB Assembly	X	O	X	O	O	O
连接器 Connectors	X	O	X	O	O	O
塑料外壳 Enclosures (Plastic)	O	O	O	O	O	O
金属外壳 Enclosures (Metal)	X	O	O	O	O	O
本表格依据 SJ/T 11364 的规定编制。 This table is prepared in accordance with the provisions of SJ/T 11364.						
O 表示该有害物质在该部件所有均质材料中的含量均在 GB/T 26572 规定的限量要求以下。 Indicates that said hazardous substance contained in all of the homogeneous materials for this part is below the limit requirement of GB/T 26572.						
X 表示该有害物质至少在该部件的某一均质材料中的含量超出 GB/T 26572 规定的限量要求。 Indicates that said hazardous substance contained in all of the homogeneous materials for this part is above the limit requirement of GB/T 26572.						
未列入表内的其他部件, 皆不含任何超出限量要求的限制使用物质。 All other components, not listed in the table, do not contain restricted substances above the threshold level						

Please send any comments about this or any other Trend technical publication to techpubs@trendcontrols.com



© 2023 Honeywell Products and Solutions SARL, Connected Building Division. All rights reserved. Manufactured for and on behalf of the Connected Building Division of Honeywell Products and Solutions SARL, Z.A. La Pièce, 16, 1180 Rolle, Switzerland by its Authorized Representative, Trend Control Systems Limited.

Trend Control Systems Limited reserves the right to revise this publication from time to time and make changes to the content hereof without obligation to notify any person of such revisions or changes.

Trend Control Systems Limited

St. Mark's Court, North Street, Horsham, West Sussex, RH12 1BW, UK. Tel: +44 (0)1403 211888, www.trendcontrols.com