Wireless Top Mounted Ultrasonic Liquid Level Sensor

**Wireless Top Mounted Ultrasonic Liquid Level Sensor
R718PE**

User Manual

Copyright©Netvox Technology Co., Ltd.

This document contains proprietary technical information which is the property of NETVOX Technology. It shall be maintained in strict confidence and shall not be disclosed to other parties, in whole or in part, without written permission of NETVOX Technology. The specifications are subject to change without prior notice.

Table of Content

1. Introduction.....	2
2. Appearance.....	2
3. Main Features	3
4. Set up Instruction.....	4
5. Data Report.....	5
6. Application scenario	10
7. Installation	11
8. Information about Battery Passivation	13
8.1 To determine whether a battery requires activation.....	13
8.2 How to activate the battery	13
9. Important Maintenance Instruction	14

1. Introduction

R718PE is a Wireless Top Mounted Ultrasonic Liquid Level Sensor device for Netvox ClassA type devices based on the LoRaWAN open protocol and is compatible with the LoRaWAN protocol.

R718PE uses ultrasound to detect the distance between the device and the detected object. The medium the device detects is the air, so the detected object can be any liquid or solid that has a flat and horizontal surface, water level.

LoRa Wireless Technology:

LoRa is a wireless communication technology dedicated to long distance and low power consumption. Compared with other communication methods, LoRa spread spectrum modulation method greatly increases to expand the communication distance. Widely used in long-distance, low-data wireless communications. For example, automatic meter reading, building automation equipment, wireless security systems, industrial monitoring. Main features include small size, low power consumption, transmission distance, anti-interference ability and so on.

LoRaWAN:

LoRaWAN uses LoRa technology to define end-to-end standard specifications to ensure interoperability between devices and gateways from different manufacturers.

2. Appearance

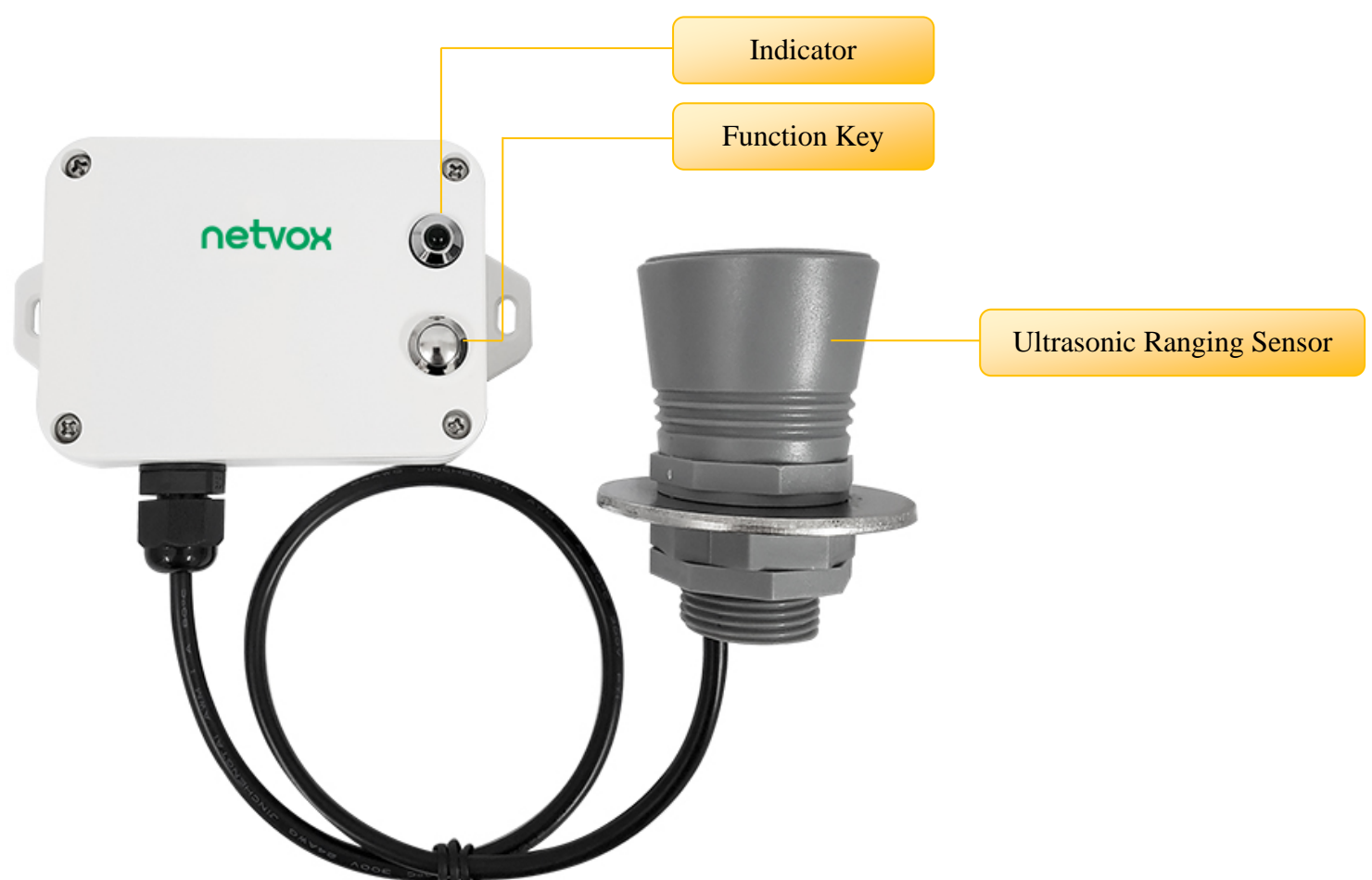

3. Main Features

- Apply SX1276 wireless communication module
- 2 sections ER14505 3.6V Lithium AA battery
- Liquid level detection
- Protection Level: IP65 / IP67 (optional), Ultrasonic Ranging Sensor: IP67
- Compatible with LoRaWAN™ Class A
- Frequency hopping spread spectrum technology
- Configuration parameters can be configured through third-party software platforms, data can be read and alarms can be set via SMS text and email (optional)
- Available third-party platform: Actility / ThingPark, TTN, MyDevices/Cayenne
- Low power consumption and long battery life

Note:

Battery life is determined by the sensor reporting frequency and other variables, please refer to http://www.netvox.com.tw/electric/electric_calc.html. On this website, users can find battery life time for varied models at different configurations.

4. Set up Instruction

On/Off

Power on	Insert batteries. (users may need a flat blade screwdriver to open)
Turn on	Press and hold the function key for 3 seconds till the green indicator flashes once.
Turn off (Restore to factory setting)	Press and hold the function key for 5 seconds till green indicator flashes for 20 times.
Power off	Remove Batteries.
Note:	<ol style="list-style-type: none"> 1. Remove and insert the battery; the device is at off state by default. 2. On/off interval is suggested to be about 10 seconds to avoid the interference of capacitor inductance and other energy storage components. 3. At 1st -5th second after power on, the device will be in engineering test mode.

Network Joining

Never joined the network	<p>Turn on the device to search the network to join.</p> <p>The green indicator stays on for 5 seconds: success</p> <p>The green indicator remains off: fail</p>
Had joined the network (not at factory setting)	<p>Turn on the device to search the previous network to join.</p> <p>The green indicator stays on for 5 seconds: success</p> <p>The green indicator remains off: fail</p>

Function Key

Press and hold for 5 seconds	<p>Restore to factory setting / Turn off</p> <p>The green indicator flashes for 20 times: success</p> <p>The green indicator remains off: fail</p>
Press once	<p>The device is in the network: green indicator flashes once and sends a report</p> <p>The device is not in the network: green indicator remains off</p>

Sleeping Mode

The device is on and in the network	<p>Sleeping period: Min Interval.</p> <p>When the reportchange exceeds setting value or the state changes: send a data report according to Min Interval.</p>
-------------------------------------	--

Low Voltage Warning

Low Voltage	3.2V
-------------	------

5. Data Report

The device will immediately send a version packet report along with an uplink packet including status, distance, filllevel and battery voltage.

Status:

When the device is used for water level detection/waste bin detection, the status always reports "0".

When the device is used for parking detection, the distance between the device and the car reaches the OnDistanceThreshold, it reports status ON.

Distance:

The distance between the device and the liquid / solid

Filllevel:

The percentage of the level in the container.

When the device is used for parking detection, the status always reports "0".

The device sends data in the default configuration before any configuration is done.

Default Setting

Maximum time: Max Interval = 15 min

Minimum time: Min Interval = 15 min

BatteryVoltageChange - 0x01 (0.1V)

DistanceChange - 0x012C(300mm)

Note:

1. The device report interval will be programmed based on the default firmware which may vary.
2. The interval between two reports must be the MinTime
3. The data parsing reported by the device is referenced by the Netvox LoRaWAN Application Command document and <http://www.netvox.com.cn:8888/page/index>

Example of ConfigureCmd

FPort: 0x07

Bytes	1	1	Var(Fix =9 Bytes)
	CmdID	DeviceType	NetvoxPayloadData

CmdID– 1 bytes

DeviceType– 1 byte – Device Type of Device

NetvoxPayloadData– var bytes (Max=9bytes)

Description	Device	CmdID	Device Type	NetvoxPayLoadData					
ConfigReportReq	R718PE	0x01	0x B1	MinTime (2bytes Unit:s)	MaxTime (2bytes Unit:s)	BatteryChange (1byte Unit:0.1v)	DistanceChange (2byte Unit:1mm)	Reserved (2byte)	
ConfigReportRsp		0x81		Status (0x00_success)			Reserved (8Bytes,Fixed 0x00)		
ReadConfig ReportReq		0x02		Reserved (9Bytes,Fixed 0x00)					
ReadConfig ReportRsp		0x82		MinTime (2bytes Unit:s)	MaxTime (2bytes Unit:s)	BatteryChange (1byte Unit:0.1v)	DistanceChange (2byte Unit:1mm)	Reserved (2byte)	
SetOnDistance ThresholdRreq		0x03		OnDistanceThreshold (2byte Unit:1mm)			Reserved (7Bytes,Fixed 0x00)		
SetOnDistance ThresholdRrsp		0x83		Status (0x00_success)			Reserved (8Bytes,Fixed 0x00)		
GetOnDistance ThresholdRreq		0x04		Reserved (9Bytes,Fixed 0x00)					
GetOnDistance ThresholdRrsp		0x84		OnDistanceThreshold (2byte Unit:1mm)			Reserved (7Bytes,Fixed 0x00)		
SetFillMax DistanceReq		0x05		FillMaxDistance (2byte Unit:1mm)			Reserved (7Bytes,Fixed 0x00)		
SetFillMax DistanceRsp		0x85		Status (0x00_success)			Reserved (8Bytes,Fixed 0x00)		
GetFillMax DistanceReq		0x06		Reserved (9Bytes,Fixed 0x00)					
GetFillMax DistanceRsp		0x86		FillMaxDistance (2byte Unit:1mm)			Reserved (7Bytes,Fixed 0x00)		

(1) Configure device parameters MinTime = 1min, MaxTime = 1min, BatteryChange = 0.1v、 DistanceChange = 500mm

Downlink: 01B1003C003C0101F40000

Device returns:

81B10000000000000000 (configuration succeeded)

81B10100000000000000 (configuration failed)

(2) Read device parameters

Downlink: 02B10000000000000000

Device returns:

82B1003C003C0101F40000 (device current configuration parameter)

(3) Configure device parameters FillMaxDistance = 5000mm

Downlink: 05B11388000000000000

Device returns:

85B10000000000000000 (configuration succeeded)

85B10100000000000000 (configuration failed)

(4) Read device parameters FillMaxDistance

Downlink: 06B10000000000000000

Device returns:

86B113880000000000000000 (device current configuration parameter)

Level Sensor Calibrate configuration example:

FPort:0x0E

Description	CmdID	SensorType	PayLoad(Fix =9 Bytes)				
SetGlobal CalibrateReq	0x01	0x36	Channel(1Byte) 0_Channel1, 1_Channel2,etc	Multiplier (2bytes,Unsigned)	Divisor (2bytes,Unsigned)	DeltValue (2bytes,Signed)	Reserved (2Bytes,Fixed 0x00)
SetGlobal CalibrateRsp	0x81		Channel(1Byte) 0_Channel1, 1_Channel2,etc	Status (1Byte,0x00_success)		Reserved (7Bytes,Fixed 0x00)	
GetGlobal CalibrateReq	0x02		Channel (1Byte,0_Channel1,1_Channel2,etc)		Reserved (8Bytes,Fixed 0x00)		
GetGlobal CalibrateRsp	0x82		Channel(1Byte) 0_Channel1, 1_Channel2,etc	Multiplier (2bytes,Unsigned)	Divisor (2bytes,Unsigned)	DeltValue (2bytes,Signed)	Reserved (2Bytes,Fixed 0x00)
ClearGlobal CalibrateReq	0x03	Reserved (10Bytes,Fixed 0x00)					
ClearGlobal CalibrateRsp	0x83	Status (1Byte,0x00_success)			Reserved (9Bytes,Fixed 0x00)		

(1)Set the calibration (GlobalCalibrate configuration):

If the distance between the device and the water R718PE detects is 490mm and the actual distance is 500mm, it means the calibration we want to make is +10mm.

Channel 1= 00, Multiplier = 000A, Divisor = 0000, DeltValue=0001

Downlink: 013600000A000000010000

Response:

813600000000000000000000 (Configuration success)

813601000000000000000000 (Configuration failure)

(2)Check whether the setting in (1) calibration

Downlink: 0236000000000000000000

Response:

823600000A000000010000 (Current configuration)

(3)Clear the setting

Downlink: 0300000000000000000000

Response:

830000000000000000000000 (Configuration success)

Note:

1. When Multiplier is not 1, Calibration value = DeltValue*Multiplier.
2. When Divisor is not 1, Calibration value = DeltValue/Divisor.
3. The choices of the Channel would be 00-03 Channel
4. With different sensor type, it is forbidden to use that same Channel number.
5. This universal calibration supports calibration of positive and negative numbers.

Example for MinTime/MaxTime logic:

Example#1 based on MinTime = 1 Hour, MaxTime= 1 Hour, Reportable Change i.e. BatteryVoltageChange=0.1V

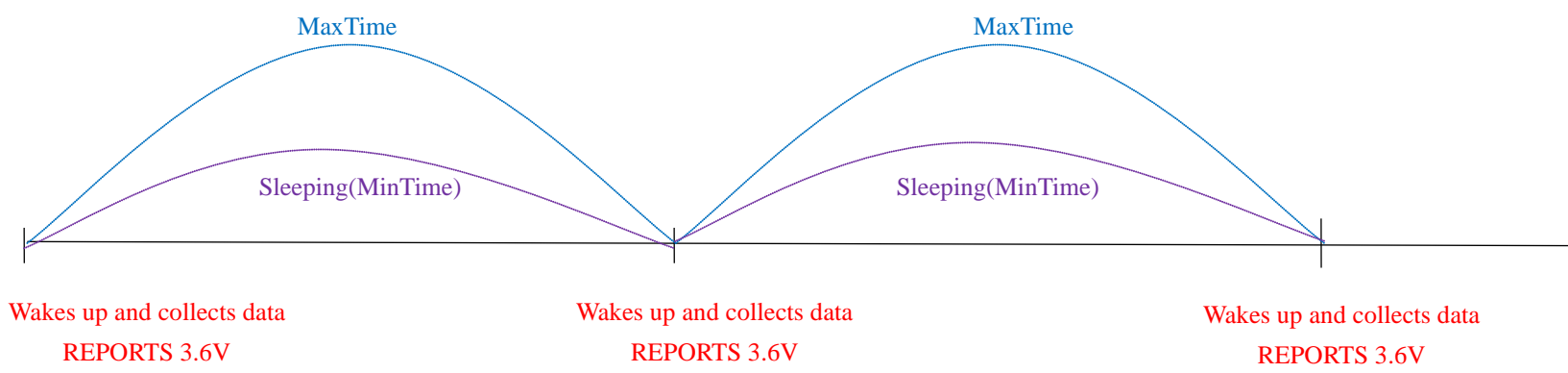

Note: MaxTime=MinTime. Data will only be report according to MaxTime (MinTime) duration regardless BatteryVoltageChange value.

Example#2 based on MinTime = 15 Minutes, MaxTime= 1 Hour, Reportable Change i.e. BatteryVoltageChange= 0.1V.

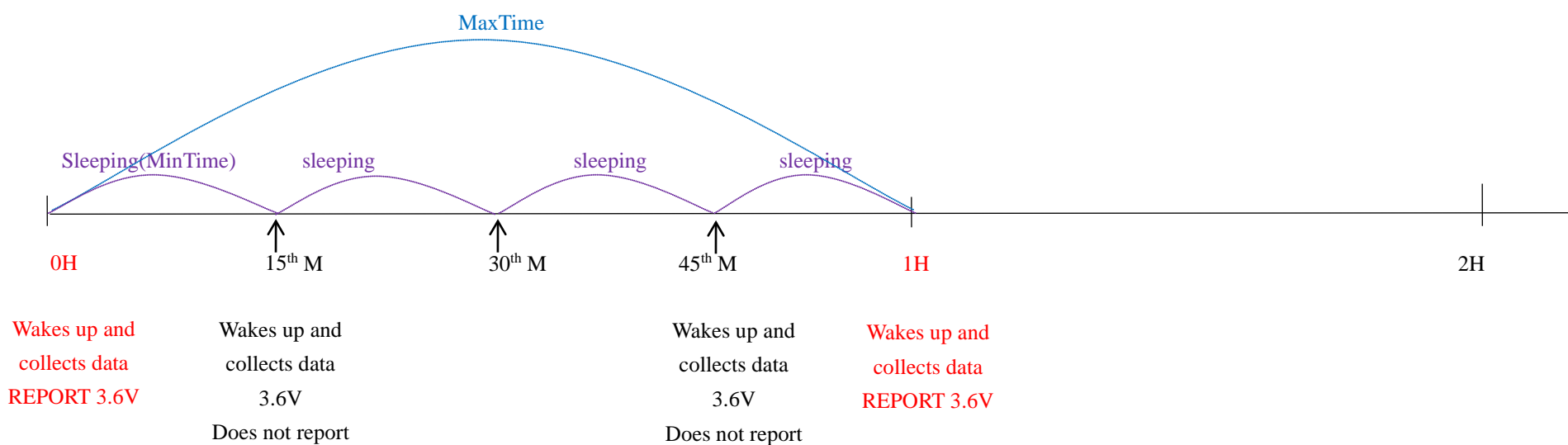

Example#3 based on MinTime = 15 Minutes, MaxTime= 1 Hour, Reportable Change i.e. BatteryVoltageChange= 0.1V.

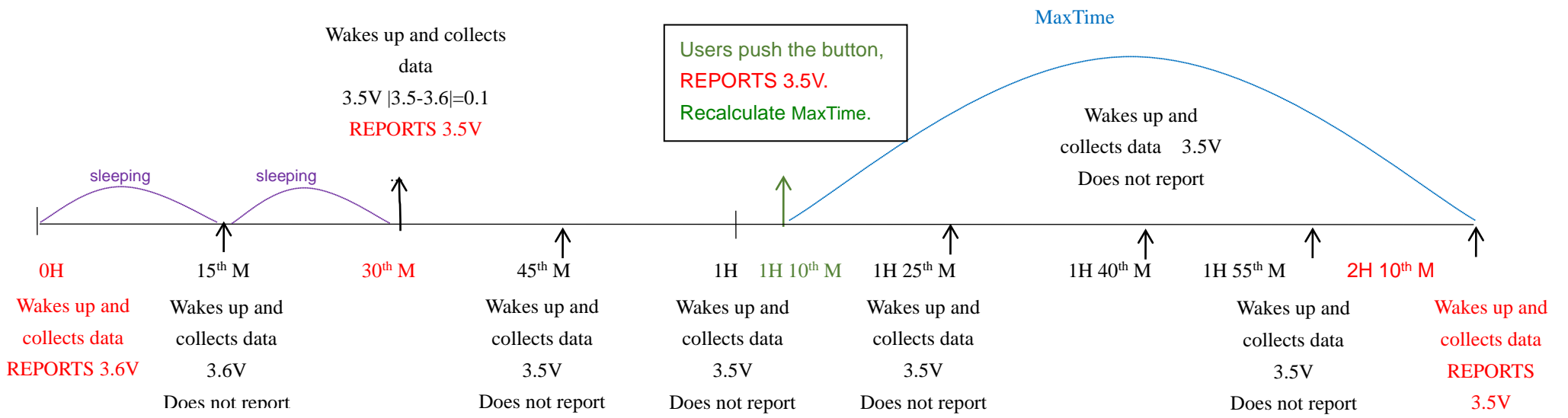

Notes :

- 1) The device only wakes up and performs data sampling according to MinTime Interval. When it is sleeping, it does not collect data.
- 2) The data collected is compared with the last data reported. If the data variation is greater than the ReportableChange value, the device reports according to MinTime interval. If the data variation is not greater than the last data reported, the device reports according to MaxTime interval.
- 3) We do not recommend to set the MinTime Interval value too low. If the MinTime Interval is too low, the device wakes up frequently and the battery will be drained soon.
- 4) Whenever the device sends a report, no matter resulting from data variation, button pushed or MaxTime interval, another cycle of MinTime/MaxTime calculation is started.

6. Application scenario

In the use case of detecting the water level in water tanks, the device should be installed on the top of the water tank.

After the device is installed and powered, turn on the device and it will detect the distance between the device and the water as well as the percentage of the water level in the water tank.

H means the height of the water tank (this value can be set with the payload command; the “fillmaxdistance” in payload means H)

D means the distance between the device and the water (this value is “distance” in uplinks)

L means the water level (this value can be calculated by the “distance” in uplink and “fillmaxdistance” in payload)

Calculation: $L = \text{fillmaxdistance} - \text{distance}$

FillLevel means the percentage of the water level in the water tank.

FillLevel = $((H - D) / H) * 100\%$

Note:

H can be set in accordance with the height of different water tanks that are used in the use case

The detecting range of the device is 250mm~8000mm

Illustration

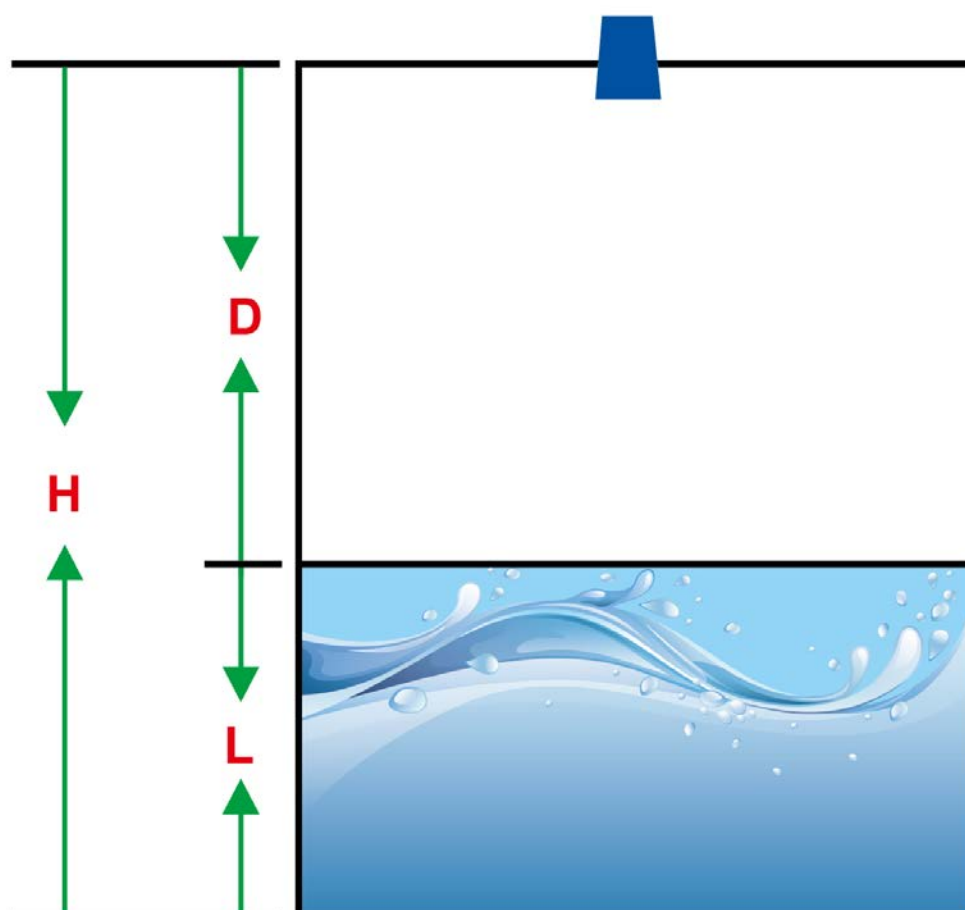

7. Installation

Kindly note the illustration is only for reference.

1. The device can be installed in the middle or anywhere of the top of the container that is flat enough to ensure the ultrasonic detection direction will be vertical to the detected object, so the accuracy can be maintained.
2. When the use case is water tank, the diameter of the water tank is recommended to be larger than 60cm.
3. Customers can refer to the below formula to see if the container is suitable:

$$\tan 7.5^\circ = A / B$$

A is the radius of the container (water tank),

B is the height of the container (water tank);

$\tan 7.5^\circ$	A	B
0.1316	3.9	30
	6.6	50
	13.2	100
	19.7	150
	26.3	200
	32.9	250
	39.5	300
	46.1	350
	52.6	400
	59.2	450
	65.8	500
	72.4	550
	79.0	600
	85.5	650
	92.1	700
98.7	750	
105.3	800	

Reference Form

Unit: cm

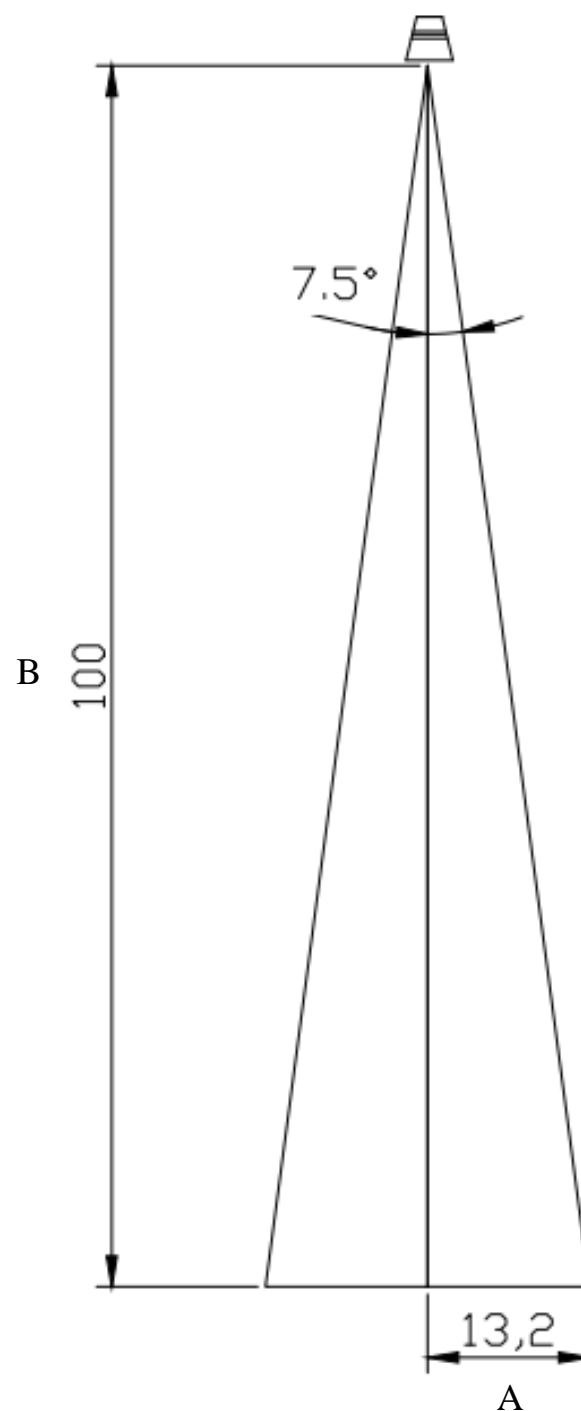

4. If the top of the water tank can be opened, it is recommended to make a hole of diameter 32mm on the top of the water tank.

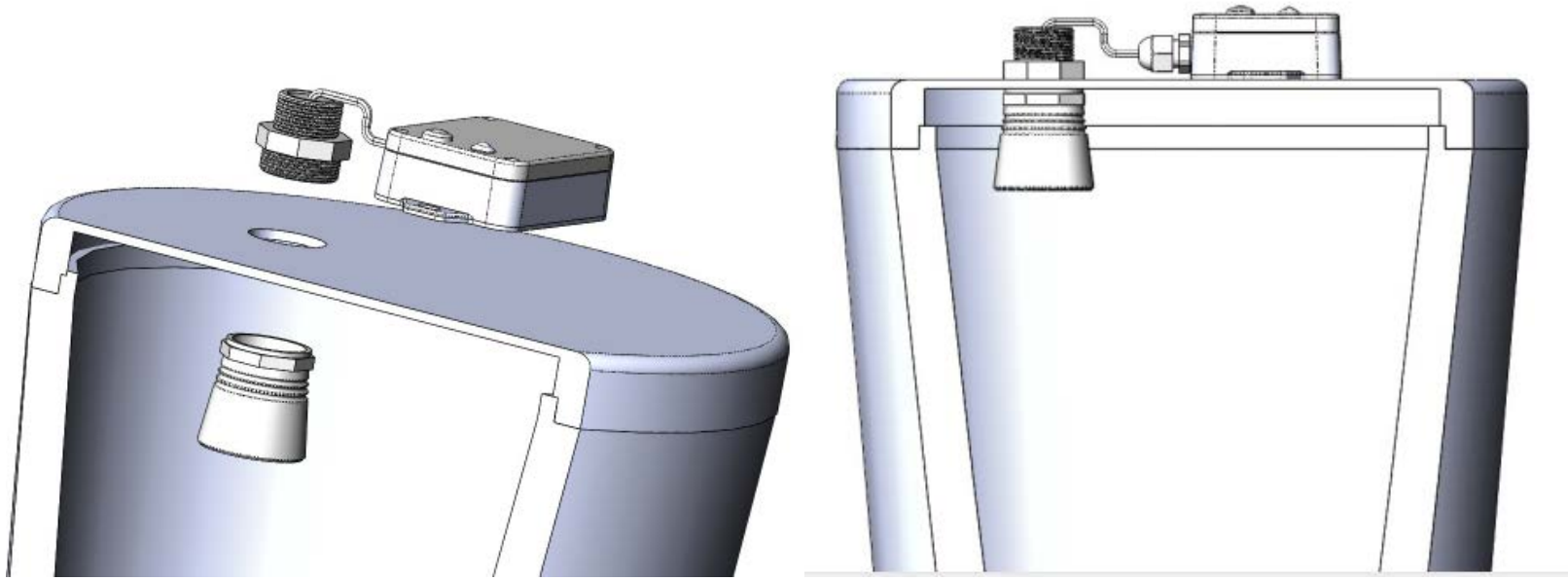

5. If the top of the water tank cannot be opened, the hole made on the top of the water tank is recommended to be 45mm diameter.

It is recommended to add a gasket (size: 32.4*57.4*3mm) between the hole and the sensor.

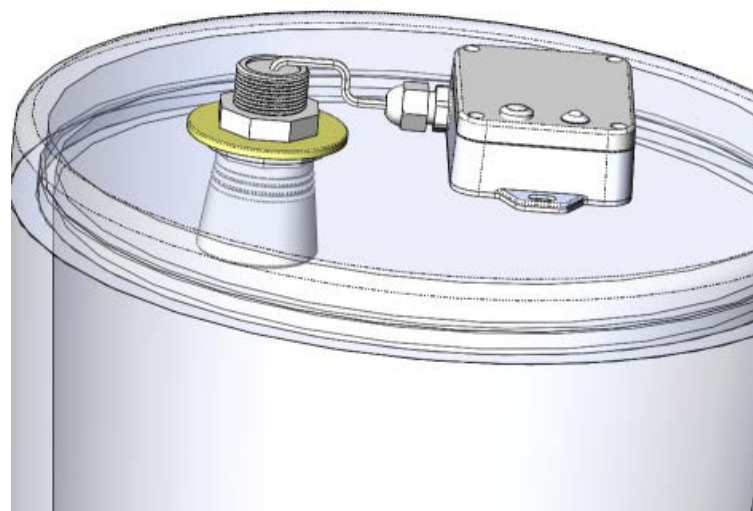
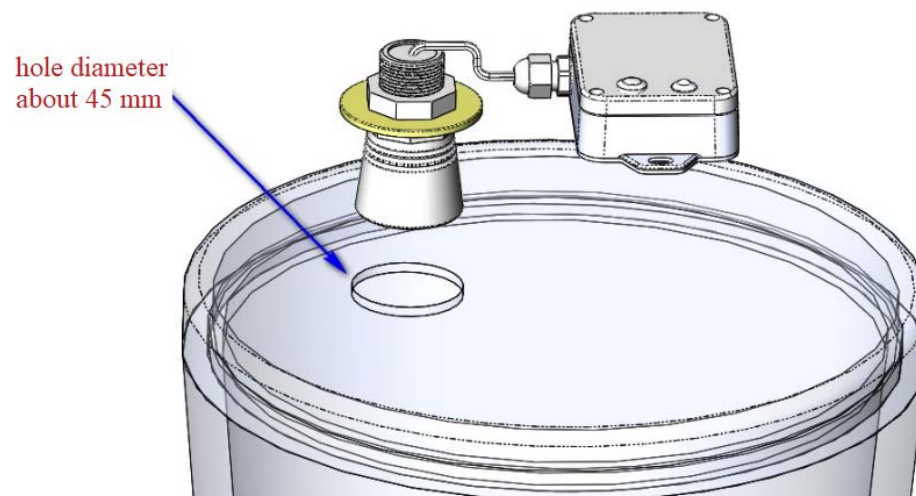
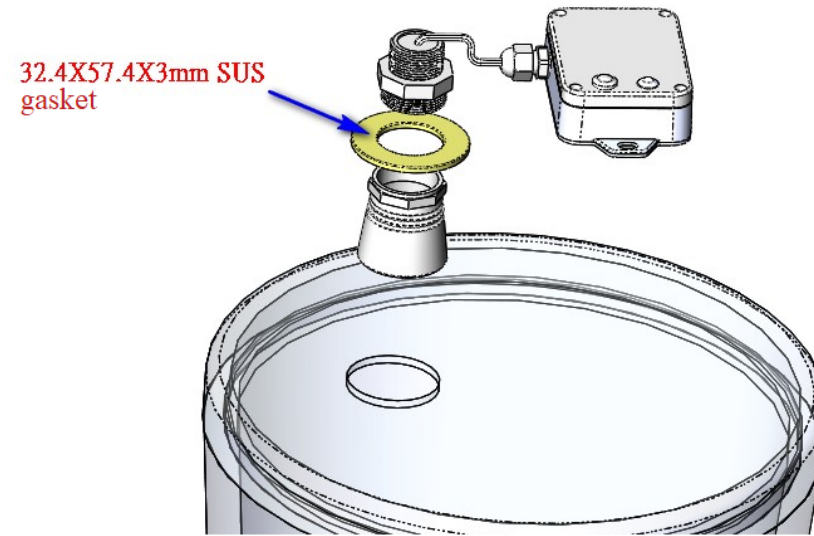

6. Movement of the detected water/liquid and foams would affect the accuracy.
7. Keep the ultrasonic detecting range from obstacles.
8. Keep the device from electromagnetic disturbances.

8. Information about Battery Passivation

Many of Netvox devices are powered by 3.6V ER14505 Li-SOCl₂ (lithium-thionyl chloride) batteries that offer many advantages including low self-discharge rate and high energy density.

However, primary lithium batteries like Li-SOCl₂ batteries will form a passivation layer as a reaction between the lithium anode and thionyl chloride if they are in storage for a long time or if the storage temperature is too high. This lithium chloride layer prevents rapid self-discharge caused by continuous reaction between lithium and thionyl chloride, but battery passivation may also lead to voltage delay when the batteries are put into operation, and our devices may not work correctly in this situation.

As a result, please make sure to source batteries from reliable vendors, and the batteries should be produced within the last three months.

If encountering the situation of battery passivation, users can activate the battery to eliminate the battery hysteresis.

8.1 To determine whether a battery requires activation

Connect a new ER14505 battery to a 68ohm resistor in parallel, and check the voltage of the circuit.

If the voltage is below 3.3V, it means the battery requires activation.

8.2 How to activate the battery

- a. Connect a battery to a 68ohm resistor in parallel
- b. Keep the connection for 6~8 minutes
- c. The voltage of the circuit should be $\geq 3.3V$

9. Important Maintenance Instruction

Kindly pay attention to the following in order to achieve the best maintenance of the product:

- Keep the device dry. Rain, moisture, or any liquid, might contain minerals and thus corrode electronic circuits. If the device gets wet, please dry it completely.
- Do not use or store the device in dusty or dirty environment. It might damage its detachable parts and electronic components.
- Do not store the device under excessive heat condition. High temperature can shorten the life of electronic devices, destroy batteries, and deform or melt some plastic parts.
- Do not store the device in places that are too cold. Otherwise, when the temperature rises to normal temperature, moisture will form inside, which will destroy the board.
- Do not throw, knock or shake the device. Rough handling of equipment can destroy internal circuit boards and delicate structures.
- Do not clean the device with strong chemicals, detergents or strong detergents.
- Do not apply the device with paint. Smudges might block in the device and affect the operation.
- Do not throw the battery into the fire, or the battery will explode. Damaged batteries may also explode.

All of the above applies to your device, battery and accessories. If any device is not working properly, please take it to the nearest authorized service facility for repair.