

PCD2.M4160, PCD2.M4560 User Manual

0	Content	
0.1	Document History	0-3
0.2	Trademarks	0-3
1	Graphical Overview	
2	Important notes	
2.1	Prerequisites	2-1
2.2	Instructions for connecting Saia PCD® controllers to the internet	2-1
3	Versions overview	
4	System overview	
4.1	X1 – USB Device	4-2
4.2	X2 – Isolated RS-485 / MPI	4-2
4.3	X3 – I/O Extension port	4-2
4.3.1	Expansion module holder	4-3
4.4	X4 – S-Bus / Watchdog / Power supply	4-5
4.5	X5 – Communication port Slot ‘A’	4-5
4.6	X6 / X7 – Dual Ethernet (Switch)	4-6
4.7	X8 – Digital interruptive inputs	4-6
4.8	X9 – Communication port Slot ‘C’	4-6
4.9	M1 – Memory Slot	4-6
4.10	BAT – Battery module slot	4-6
5	Power supply	
6	LED behaviour	
7	Run / Stop button	
8	I/O Bus slots and I/O extension port	
8.1	PCD2.M4160	8-1
8.2	PCD2.M4560	8-1
9	Data retention, Real time clock and battery module slot	
9.1	Usage of optional battery module	9-1
9.2	User program data	9-1
10	Interruptive- or digital inputs terminal block X8	
10.1	Usage as normal digital inputs	10-1
10.2	Usage as interruptive inputs	10-2
10.3	Usage as CPU onboard Counter	10-3
10.3.1	Introduction	10-3
10.3.2	Function Description	10-4
10.3.2.1	Function Block Diagram	10-4
10.3.2.2	Function Description (applies to counter 0 as well as to counter 1)	10-4
10.3.2.3	Counter Mode Description	10-5
10.3.2.4	System Function Parameters	10-6

11 Watchdog relay**12 Communication ports**

12.1	X1 - USB Port (Programming Interface)	12-1
12.2	X2 – Isolated RS-485-Port/MPI	12-2
12.3	X4 - RS-485 (Port #0, not electrically isolated)	12-3
12.4	X5 - Sot A (Port #1) Terminalbloc	12-4
12.5	X6 and X7 - Ethernet Switch Port #9	12-5
12.6	X9 - Slot C Profibus-DP-Master (Port #8) optional	12-6
12.7	I/O module based interfaces PCD2.F2xxx	12-9

13 Dimensions**14 Mounting**

14.1	Mounting with screws	14-2
14.1.1	Mounting the PCD2.M4x60 and PCD2.C1000:	14-3
14.1.2	Dismounting the PCD2.M4x60 and PCD2.C1000:	14-3
14.2	DIN rail mounting	14-4
14.2.1	Mounting the PCD2.M4x60 and PCD2.C1000:	14-5
14.2.2	Dismounting the PCD2.M4x60 and PCD2.C1000:	14-5

A Annex

A.1	Icons	A-1
A.2	Waste of Electrical and Electronic Equipment (WEEE) disposal	A-1
A.3	Contact	A-2

0.1 Document History

Version	Changes	Comments
ENG01	2015-10-26	First edition
ENG02	2016-08-17	- Power supply - Mounting with screws and DIN-rails
ENG03	2016-09-02	- New pictures for mounting with screws
ENG04	2016-12-12 2017-03-08	- Restrictions on communication port Slot 'A' - Chap. 10.3 Module internal counter - new
ENG05	2018-05-16 2018-05-16 2018-06-15	- Some pictures improved - Techn. Data added with watchdog relay. - PCD2.C1000 / 2000 Extension housing inserted - Corrected in the "Graphical Overview" link - "ambient conditions" added in 3.2 - Correction Chap. 10.3.2.1 PAD/PED6500 in 65000
ENG06	2020-10-21	- Added chapter 4.3.1 "X3 – I/O Extension port" - Added reference to WEEE in the annex - Chapter 10 extended - Chapter 12 reworked

0.2 Trademarks

Saia PCD® is a registered trademark of Saia-Burgess Controls AG.

Technical changes are subject to the state of technology.

Saia-Burgess Controls AG, 2020. © All rights reserved.

1 Graphical Overview

The graphical overview shows some of the main topics covered in the Operating Manual of the PCD2.M4160 and PCD2.M4560.



By clicking on the highlighted components and/or connections, you can jump directly to the corresponding chapter in the document.
 “Kap. number” indicate the relevant chapter numbers.

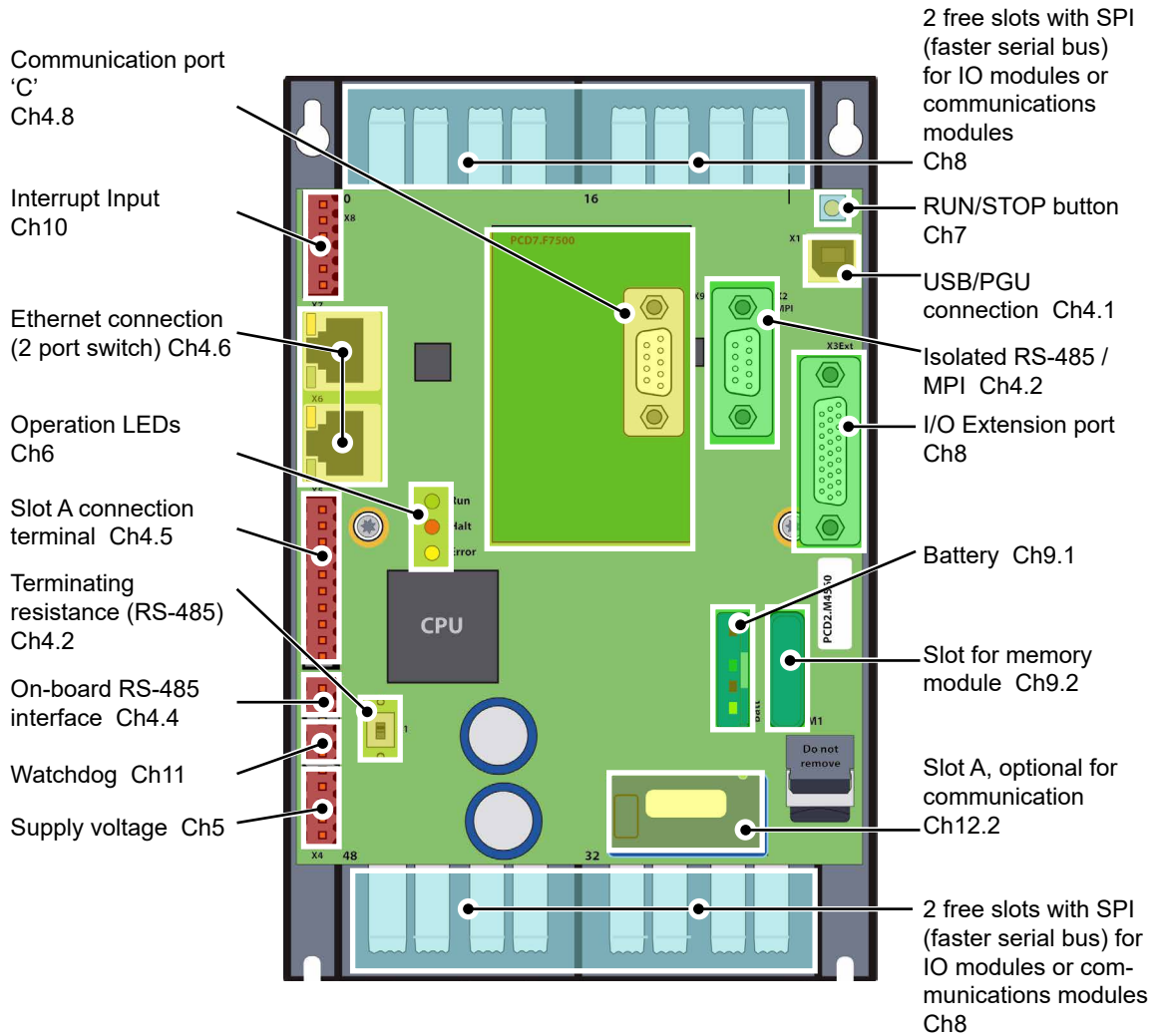

2 Important notes

2.1 Prerequisites

The PCD2.M4x60 must be used with the PG5 Suite v2.2.050 or higher.

2

2.2 Instructions for connecting Saia PCD® controllers to the internet



When Saia PCD controllers are connected directly to the internet, they are also a potential target of cyber attacks. For secure operation, appropriate protective measures must always be taken.

PCD controllers include simple, built-in protection features. However, secure operation on the internet is only ensured if external routers are used with a firewall and encrypted VPN connections.

For more information, please refer to our support site:

www.sbc-support.com/security

3 Versions overview

	PCD2.M4160	PCD2.M4560
Number of onboard digital inputs	4 digital inputs (24 V, configurable: Normal, Interrupt, Counter)	
Number of digital inputs/outputs in the base unit	64	
Or I/O module slots in the base unit	4	
Number of digital inputs/outputs with PCD2.C1000/PCD2.C2000 module holders	–	1023
or I/O module slots	–	60
Processing times [µs]	Bit-Operation 0.1...0.8 µs Word-Operation 0.3 µs	
Real-time clock (RTC)	Yes	
Supercap to support the real-time clock	> 10 days	
Slot for optional battery module Order article number: 4 639 4898 0	Yes, to support the real-time clock for > 3 years	

3

Onboard memory

Program memory, DB/TEXT (Flash)	512 kByte	2 MByte
Working memory, DB/TEXT (RAM)	128 Kbyte	1 Mbyte
Flash memory (S-RIO, Konfiguration und Backup)	128 Mbyte	128 Mbyte
User flash file system (INTFLASH)	8 Mbyte	128 MByte
Data backup with FRAM technology (the data will remain when system is unpowered)	for R, F, DB, TEXT	for R, F, DB, TEXT

Onboard communication interfaces

USB 1.1	<= 12 Mbit/s	
Ethernet, 2 Port Switch	10/100 MBit/s, full duplex, autosensing/crossing	
RS-485 on terminal block (Port 0)	<= 115.2 kbit/s	
RS-485 free protocol on D-Sub connector (Port 2) or RS-485 Profibus DP Slave, Profi-S-Net D-Sub connector (Port 10)	No	<= 115.2 kBit/s <= 1.5 Mbit/s (galv. sep.)

Optional communication interfaces

PCD2.F2xxx Module for RS-232, RS-422, RS-485, BACnet® MS/TP, Belimo MP-Bus, DALI und M-Bus	I/O slot 0...1 2 Modules	I/O Slot 0...3 4 Modules
Slot A for PCD7.F1xxx Module	yes	
Slot C for Profibus Module PCD7.F7500 (Port 8)	No	yes

Ambient conditions

Ambient temperature	With assembly on a vertical surface with vertically aligned terminals: 0...+55 °C For all other installation positions, a reduced temperature range of 0...+40 °C applies
Storage temperature	-25...+85 °C
Relative humidity	10...95 % without condensation

3

General specifications

Supply voltages (in accordance with EN/IEC 61131-2)	24 VDC -20/+25% max. incl. 5% ripple ±15%
Power consumption	Typ. 15 W with 64 I/O
Load capacity 5 V/ +V intern	max. 800 mA/250 mA

Order details

PCD2.M4160	PCD2 processor unit with Ethernet-TCP/IP, 512 kB program memory, 64 I/O
PCD2.M4560	PCD2 processor unit with Ethernet-TCP/IP, 2 MB program memory, 1023 I/O

4 System overview

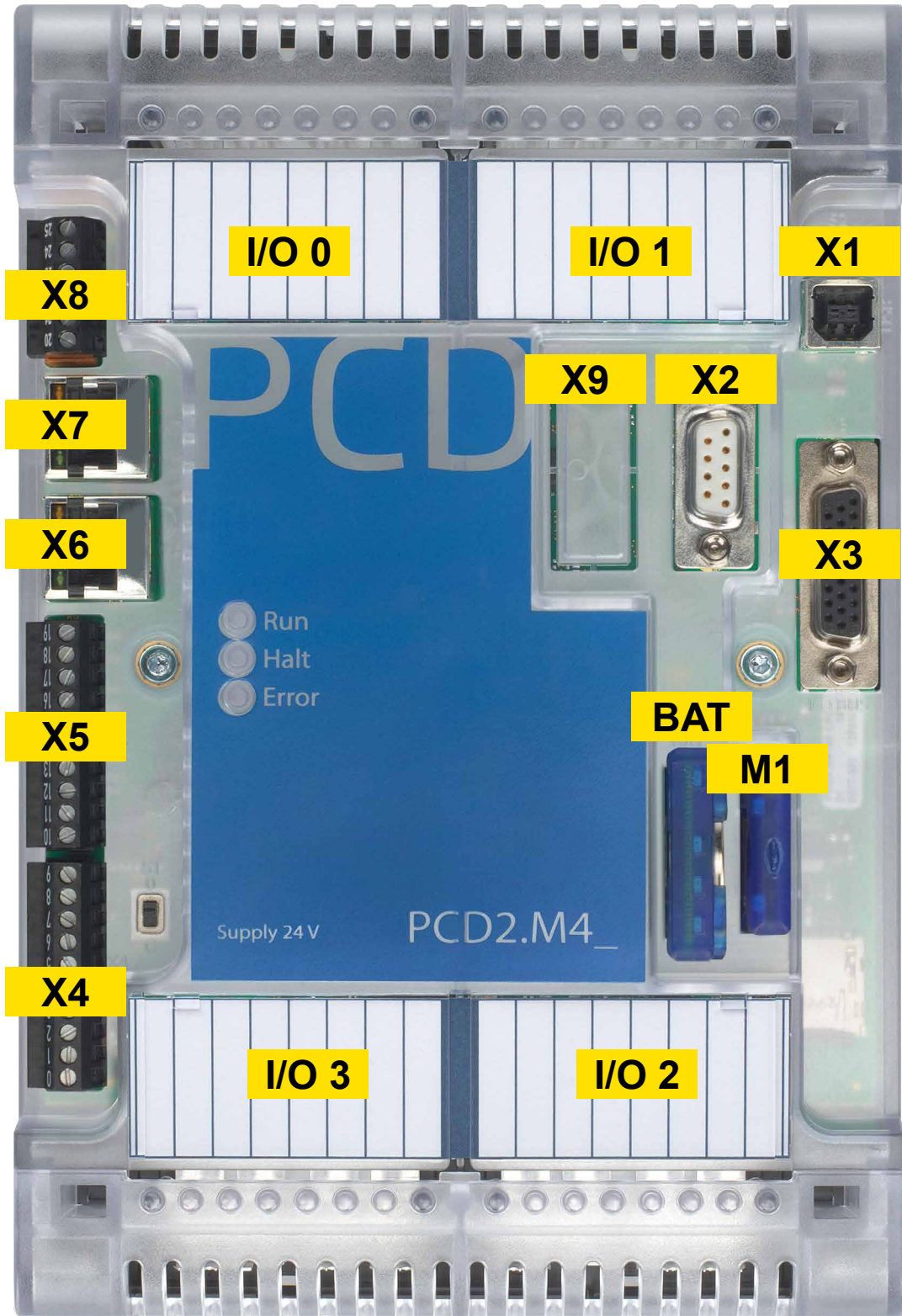

PCD2.M4560

4.1 X1 – USB Device

USB device (V1.1) on type 'B' connector.

4.2 X2 – Isolated RS-485 / MPI

SUBD 9p connector

S-Net/MPI/RS-485		
D-Sub pin	signal	Explanation
1	PGND	GND
2	GND	0 V of 24 V supply
3	RxD/TxD-P ¹⁾ B (red)	Receive/transmit data positive
4	RTS/CNTR-P	Control signal for repeater (direction control)
5	SGND ¹⁾	Date communication potential (earth to 5 V)
6	+5V ¹⁾	Supply voltage to P line termination resistors
7	MPI24V	Output voltage plus 24 V
8	RxD/TxD-N ¹⁾ A (green)	Receive/send data negative
9	not used	

4

- 1) For Profibus mandatory signals (must be provided by the user). Specially the both signals SGND and +5V are provided by the PCD, if the Profibus configuration is correct.

4.3 X3 – I/O Extension port

SUBD 26p for I/O Bus extension plug PCD2.K010 or extension cables PCD2.K106.

Only the I/O extensions with integrated power supply are compatible (PCD2.C1000, PCD2.C2000, PCD3.C200)

4.3.1 Expansion module holder

The PCD2.C1000 or PCD2.C2000 expansion module holder, also known as LIO module rack, provides space for 4 or 8 additional I/O modules each.

The PCD2 expansion module holder are also snapped onto two 35 mm DIN rails mounted in parallel.

LIO module rack	Module places	Description	External power supply	Internal Power supply I at +5 V
PCD2.C1000	4	for 4 (or 8) I/O modules, serves as I/O bus repeater and provides internally +5V and V+ for a segment of I/O modules.	24 VDC	1400 mA
PCD2.C2000	8			

I/O bus connectors PCD2.K010 or I/O bus cables PCD2K106 can be used to connect the expansion boxes.

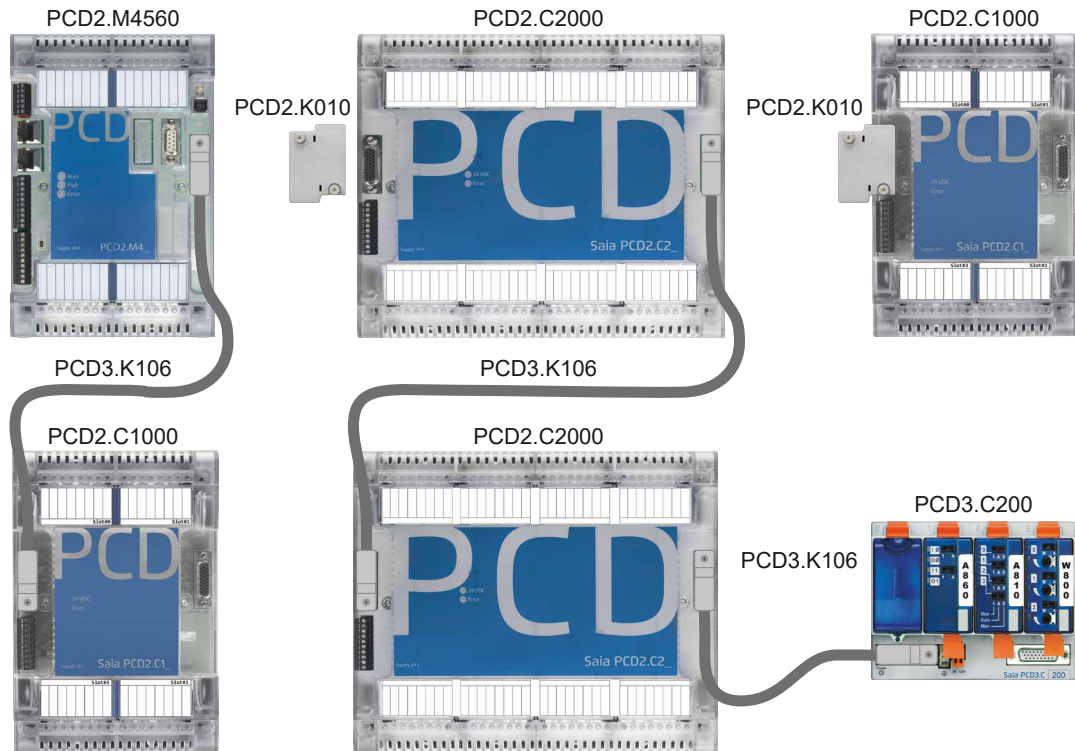

The dimensions of the module holders are compatible with those of the base unit PCD2.M5xxx or in width, half of it.

The local slots on the base unit (CPU) are numbered starting at the upper left slot 0 clockwise to slot 3. The expansion module holders are also numbered clockwise from slot 4 upwards, etc. The I/O addresses are also numbered in the same way.

PCD2.C1000 and PCD2.C2000 serve as bus repeaters and provide +5V and V+ internally for a segment of I/O modules.

The order of the expansion module holders is freely selectable.

PCD3.C200 expansion module holders can also be used.



PCD3.Cxxx expansion module holders enable the use of PCD3 manual control modules e.g. the «Light and Shading» module PCD3.A860

Connections of the PCD2.C1000 and PCD2.C2000 expansion module holders

Power supply of the expansion module holder

4

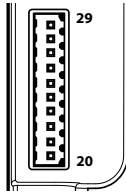

Pin	Désignation	Signification
29	Power Fail (Panne de courant)	+5 V ou V+ non disponible
28	Power Good	Tensions présentes
27	COM	Port commun
26	n.c.	non connecté
25	n.c.	non connecté
24	-	GND
23	-	GND
22	+	+24 V
21	+	+24 V
20	+	+24 V

The PCD2.C1000/C2000 module holders provide the following internal supply currents for the inserted or connected modules:

Type	Maximal current		Power consumption
	+5V	V+	
PCD2.C1000 PCD2.C2000	1400 mA	800 mA	In der Regel 2W

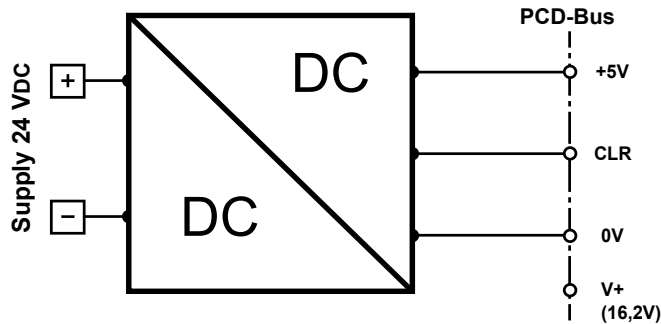

When planning PCD2 systems, it is important to check that the internal power supplies to the I/O module racks are not overloaded. This check is especially important when using analog, counting and positioning modules, as some of these modules have a high power consumption.



It is recommended to use the calculation table a www.sbc-support.com.

Extension connection

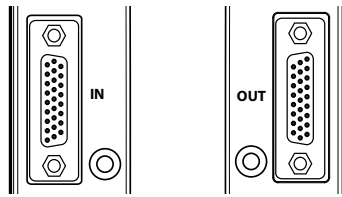

These connections can be used to connect the PCD2.C1000/C2000 expansion housing to other expansion housings using the PCD2.K010 connector plug or the PCD2.K106 connecting cable. This allows up to 1023 digital I/Os to be implemented.

LEDs

- 24 VDC (yellow): Power supply available (19 V...32 VDC)
- Power Fail (red): Short circuit (+5 V or V+ not present)



4.4 X4 – S-Bus / Watchdog / Power supply

Connector inscription	9	8	7	6	5	4	3	2	1	0
Signal	D	/D	-	WD	WD	-	-	+	+	+
Description	S-Bus (RS-485) Port 0			Watchdog Relaycontact		power supply				
See chapter ...	Chapter 12			Chapter 11		Chapter 5				

4.5 X5 – Communication port Slot ‘A’

	PCD7.F121S ¹⁾²⁾³⁾	PCD7.F110S		PCD7.F180S	PCD7.F150S	PCD7.W600 ³⁾⁴⁾
	RS-232	RS-485	RS-422	Belimo	RS-485, isol.	4×AO (0...+10 V)
10	PGND	PGND	PGND	PGND	PGND	PGND
11	TxD	Rx-Tx	Tx	MP	Rx-Tx	A0+
12	RxD	/Rx-/Tx	/Tx	„MFT“	/Rx-/Tx	A0-
13	RTS		Rx	„IN“		A1+
14	CTS		/Rx			A1-
15	PGND	PGND	PGND	PGND	PGND	PGND
16	DTR ²⁾		RTS			A2+
17	DSR ²⁾		/RTS			A2-
18	COM		CTS		SGND*	A3+
19	DCD ¹⁾		/CTS			A3-

* SGND is signal return for Rx-Tx-/Rx-/Tx signals and is isolated from PGND.
 4) The plug-in module PCD7.W600 (4 analogue outputs) is described in the manual 27-634_ENG.

Please refer to the PCD7.F1xxS module descriptions in chapter 12 Communication Ports.

Note	HW version	Restrictions
1)	rev. A	The signal "DCD" for modem communication is not supported.
2)	rev. B	- Issue with "DTR" signal, RS-232 full protocol with handshake on DTR-DSR-signals not supported. - Modems are supported (without DTR signal).
3)	rev. C and higher	- RS-232 full protocol issue is corrected. - Modems and PCD7.W600 are fully supported.

4.6 X6 / X7 – Dual Ethernet (Switch)

Dual Ethernet port with integrated switch 10/100M.

4.7 X8 – Digital interruptive inputs

Four digital inputs configurable interruptive functions.

Connector inscription	25	24	23	22	21	20
Signal	DI_IX3	DI_IX2	DI_IX1	DI_IX0	–	–

4

4.8 X9 – Communication port Slot ‘C’

A hole is foreseen in the housing for the SUBD connector of module PCD2.F7500.

4.9 M1 – Memory Slot

Slot for memory modules like PCD7.R610 for example.

4.10 BAT – Battery module slot

Slot for PCD3 battery module.

5 Power supply

Supply voltage: 24 VDC -20 % ... +25 %

Power consumption: Typically 15 W

Capacity of internal 5V / V+ bus: 800 mA / 250 mA

Connection terminals

PCD2.M4x60

5

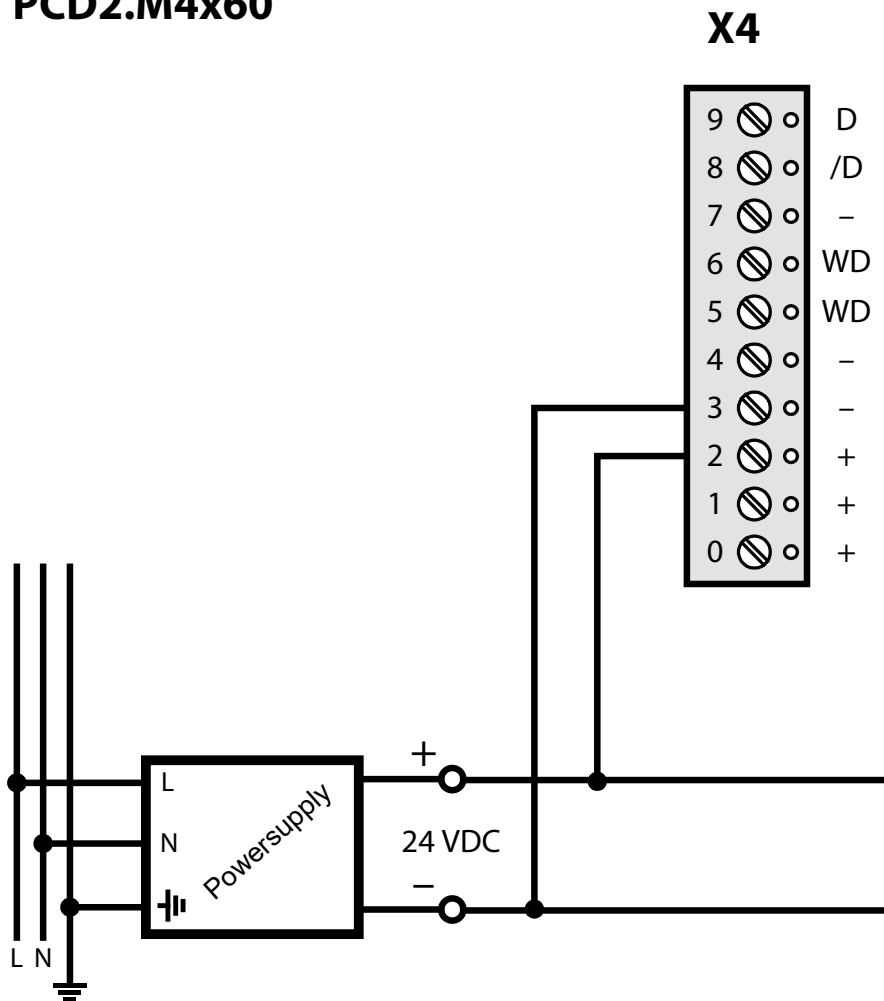

6 LED behaviour

Three LEDs (green, red and yellow) show the possible operating statuses of the CPU as set out in the following table:

Meaning	Run	Stop	Error(s)
Form			
Colour	green	red	yellow
Run			
Run conditional			
Run with error			
Run conditional with errors			
Stop			
Stop with errors			
Halt			
System diagnostics			

Key:

- LED off
- LED on
- LED blinks

7 Run / Stop button

A push button is placed near the USB connector.



7

The operating mode can be changed during operation or during power-up.

If the button is pressed in Run mode for longer than ½ second and less than 3 seconds, the controller switches to Stop mode and vice versa.

If the button is pressed for longer than 3 seconds, the last saved user program is loaded from the flash memory.

8 I/O Bus slots and I/O extension port

8.1 PCD2.M4160

Four I/O Slots available in the PCD, addresses from 0 to 63.

The communication modules (PCD2.Fxxx) or memory modules (PCD2.Rxxxx) can be connected in slots 0 or 1, but not in slots 2 or 3.

8.2 PCD2.M4560

Four I/O Slots available in the PCD, addresses from 0 to 63.

The communication modules (PCD2.Fxxx) or memory modules (PCD2.Rxxxx) can be connected in the four I/O slots of the PCD.

The extensions PCD2.C1000 or PCD2.C2000 can be chained up to address 1023 (including the 64 addresses available in the PCD itself. That means 64 I/O modules can be connected to the system.

8

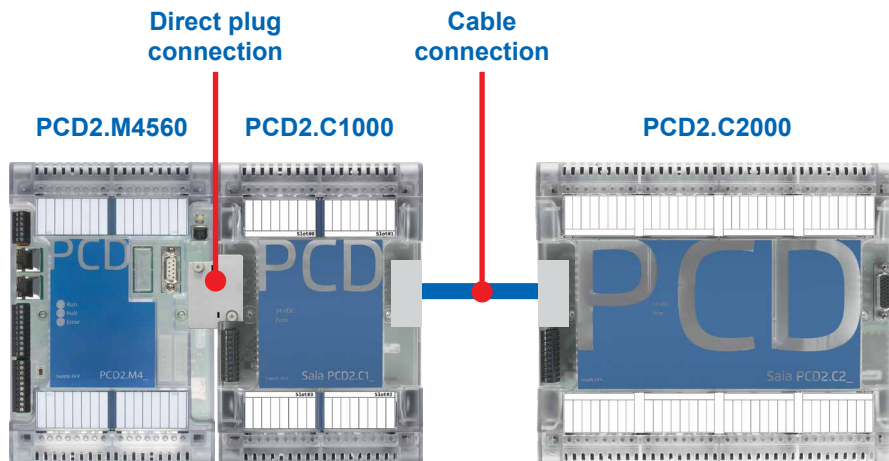

9 Data retention, Real time clock and battery module slot

9.1 Usage of optional battery module

The slot for the PCD3 battery module will be unused for the most of applications. This option will be used only for customers they need to keep the real time clock up to date when the system stays unpowered more than 10 days.

For an unpowered duration up to 10 days, the real time clock stays alive by a super-capacitor.

9.2 User program data

The user program medias (registers, flags, etc.) are stored in a non-volatile memory. That means the information is not lost when the system is unpowered and even if the system has no battery module plugged.

10 Interruptive- or digital inputs terminal block X8

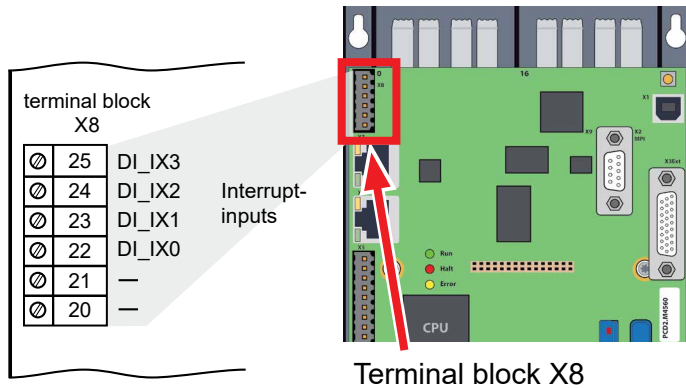

Digital inputs respecting standard IEC 61131-2:

Voltage input lower than 5 V is considered as state “low” and voltage higher than 15 V is considered as state “high”.

Maximum input voltage = 30 V.

10.1 Usage as normal digital inputs

10

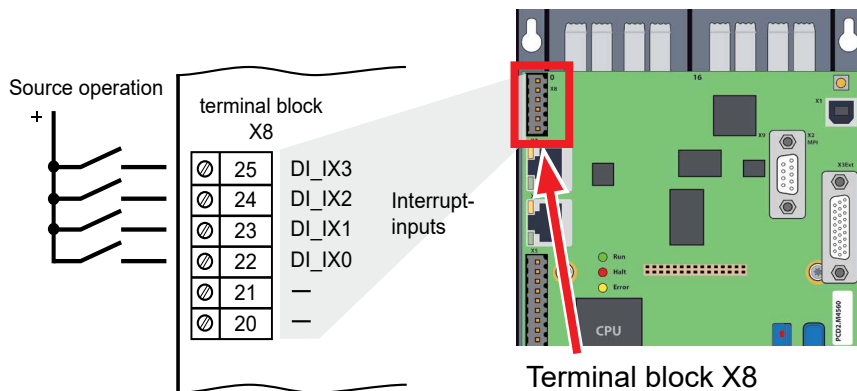

To use the digital inputs as normal inputs, choose the mode “Input” in the device configurator.

Device configurator

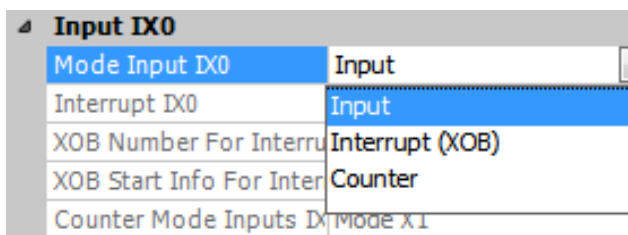

10.2 Usage as interruptive inputs

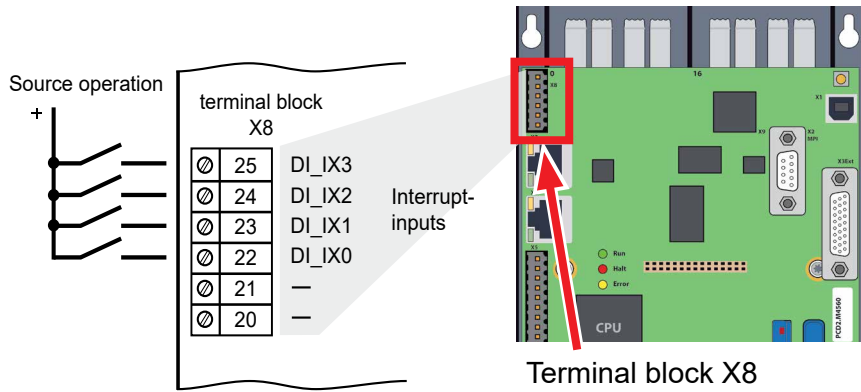

To use the digital inputs as interruptive inputs, choose the mode “Interrupt”. The interrupts can be triggered on rising edge, falling edge or both.

A XOB is called when an interrupt is detected. The XOB number is configured by default at XOB 20 for input 0 up to XOB23 for Input 3.

Input	Assigned to
DI_IX0	XOB 20
DI_IX1	XOB 21
DI_IX2	XOB 22
DI_IX3	XOB 23

Device configurator

Input IX1	
Mode Input IX1	Interrupt (XOB)
Interrupt IX1	On falling edge
XOB Number For Interrupt	21
XOB Start Info For Interrup	0

10.3 Usage as CPU onboard Counter

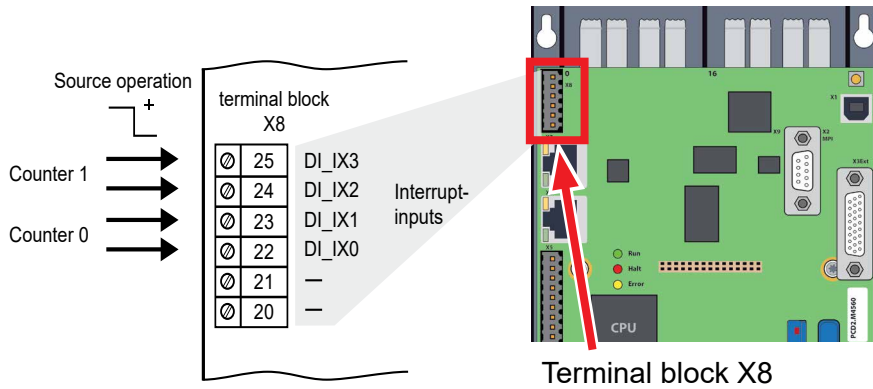

10.3.1 Introduction

The four Interrupt Inputs can be used as two independent On board Counters. This On board Counter is counting independent of the CPU Cycle.

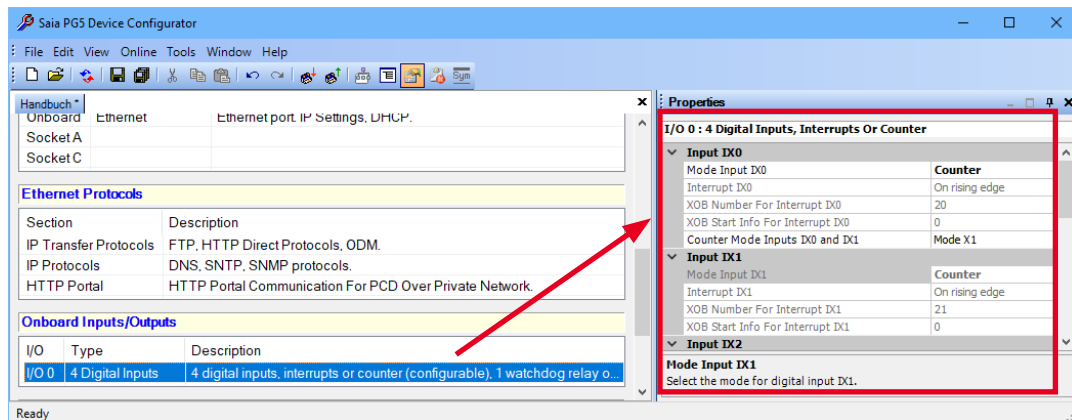

As soon as “Counter” is selected in the Device Configurator for the interrupt connections, two interrupts are reserved for each of the two counters (clearly visible in the Device Configurator (red frame, second counter greyed out) and in the drawing above at the pin assignment counter 0 and 1).



- The onboard Counter is able to count bidirectional.
- The Overflow handling is configurable. If a configurable reference value is reached, it is possible to call a Process Alarm XOB.
- The max counter Frequency is limited to 1 kHz.

10.3.2 Function Description

10.3.2.1 Function Block Diagram

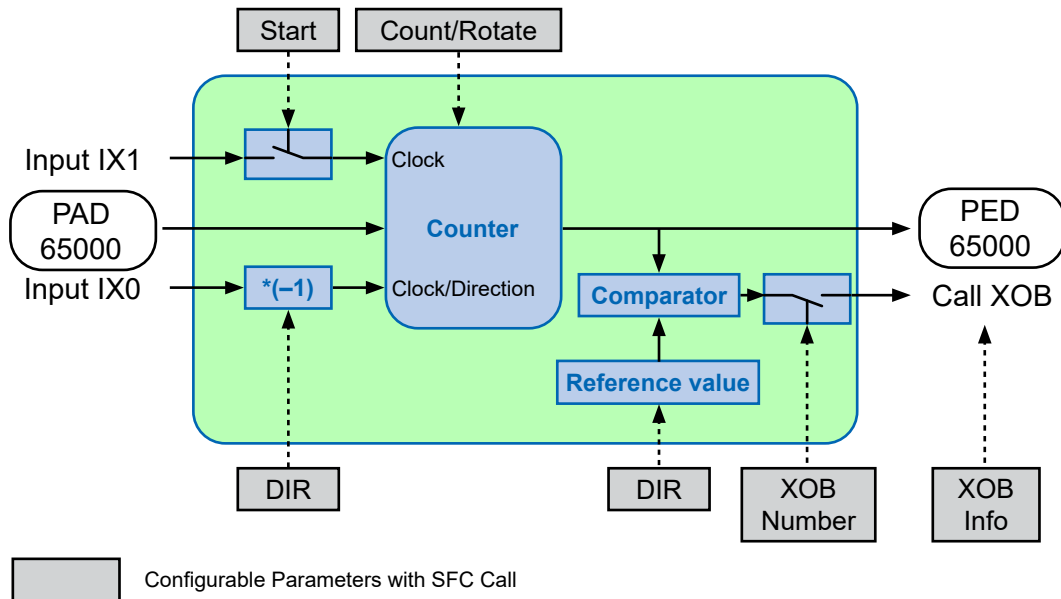

10.3.2.2 Function Description (applies to counter 0 as well as to counter 1)

To configure, to start and stop the Onboard Counter there exist a system call (BOARDCNT). For the configuration and to start the Counter only a single call of the system call is necessary. The Counter value can be read with a direct periphery access on address 65'000 / 65004. The Value of the Counter can be set at any time with a direct periphery write access to address 65'000 (Counter 0) or 65004 (Counter1).



- On a startup, the Counter is preset to 0.
- If the PCD goes to halt the counter is stopped.
- To change the Counter Parameter, the counter must be stopped.

ROTATE (round counting)

In the Rotate Mode the counter counts up to the Reference Value (Parameter Ref) and starts then from 0. Or it counts down to 0 and starts with the Reference Value. In "normal" Mode the CountingRange is from 0 to 0xFFFF'FFFF.

10.3.2.3 Counter Mode Description

The Counter Mode is configured in the IO-Configuration (On Board IO's Inputs / Interrupts / Counter / Watchdog)

X1 Encoding

In this mode, the counter is set on every positive edge of A and counts up or down depending on the B state.

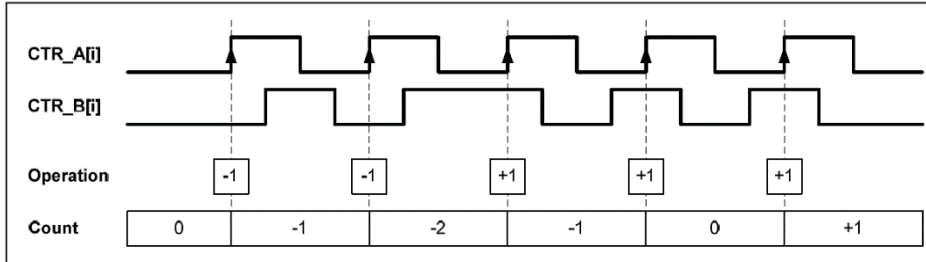

X2 Encoding

The same behavior holds for X2 encoding except the counter increments or decrements on each edge of channel A, depending on which channel leads the other. Each cycle results in two increments or decrements, as shown in Figure.

10

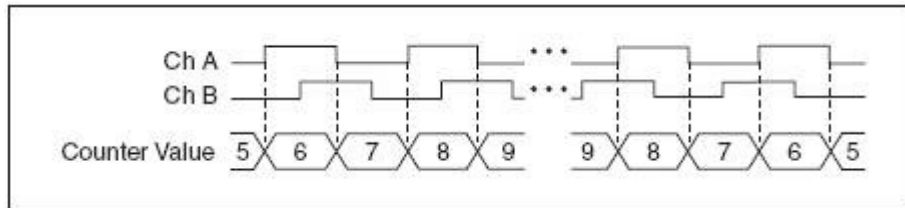

X4 Encoding

The counter increments or decrements similarly on each edge of channels A and B for X4 encoding. Whether the counter increments or decrements depends on which channel leads the other. Each cycle results in four increments or decrements, as shown in Figure.

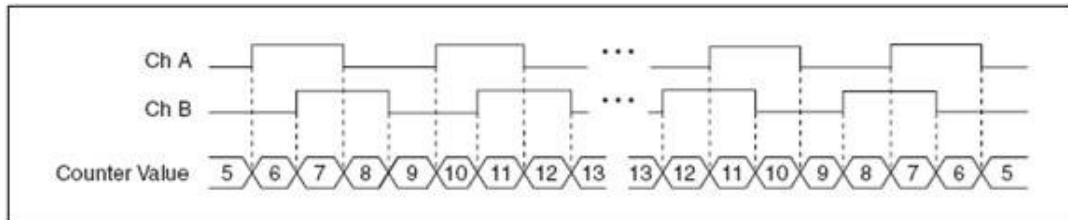

10.3.2.4 System Function Parameters

With the System Function Library Number 17 Function Number 1 it is possible to start / stop and Configure the OnBoard Counter.

The following table displays the Parameters:

Parameter	Declaration	Type	Range	Description
COUNT_NUM	Input	R K Wert	0	0: Counter 0 1: Counter 1
START/STOP	Input	F	TRUE / FALSE	Start or Stop the Counter
CONT	Input	F	TRUE / FALSE	True: Continuous counting False: Counting until the ref value is reached
ROTATE	Input	F	TRUE / FALSE	True: Overflow handling, see description Rotate False: No Overflow handling
DIR	Input	F	TRUE / FALSE	Only in Mode X0 and X1 True: Input IX0 is inverted False: Input IX0 is not inverted
REF_OUT	Input	F	TRUE / FALSE	This Functionality is not supported (set Always to FALSE)
PULSE_OUT	Input	F	TRUE / FALSE	This Functionality is not supported (set Always to FALSE)
REF	Input	R K Wert	xxx ¹⁾	Maximum Value or Reference Value
XOB_NBR	Input	R K Wert	0 32...63	0: No XOB call if Counter Value is equal Ref Value 32...63: XOB is called if the Counter reaches the Ref Value
XOB_INFO	Input	R K Wert	YYYY ²⁾	This Value can be read in the XOB local data.
RET_VAL	Output	R	ZZZZ ³⁾	Error and status message: 0: Counter started 1: Counter already running (called when START=TRUE) -2: COUNT_NUM is invalid (0) -3: XOB_NBR is invalid -4: Counter Inputs are configured as Interrupts -5: Configuration with COUNT = TRUE, ROTATE=TRUE, and REF = 0
REF_REACHED	Output	F	TRUE / FALSE	This Flag is set if the Ref Value was reached. The Flag will be reset after the call.

1) 4 Byte Range from 0x0000'0000 to 0xFFFF'FFFF.

2) 2 Byte Range from 0x0000 to 0xFFFF.

3) Integer Range from -32768 to +32767.

11 Watchdog relay

PCD2.M4_ CPUs have a hardware watchdog as standard equipment. The watchdog relay is at Pins 5 and 6 at Plug X4.

Technical data	
Number of outputs	1× relay switching contact
Function	Watchdog function or user output (selectable)
Max. voltage	48 VAC or VDC
Switching capacity	1 A (with DC switch-on voltage, a freewheeling diode should be connected in parallel to the load)

Functional description

As soon as the watchdog relay is called at the address O 255 by a switch on/off frequency of < 200ms (or other value configured in device configurator), the relay contact closes. It remains closed until the pulse time exceeds the configured value.

Example of an instruction list (IL) sequence:

Label	Command	Operand	Comment
	COB	0 0	; or 1 ... 15
	STL	WD_Flag	; invert the help flag
	OUT	WD_Flag	
	OUT	O 255	; Output 255 blinking
	ECOB		

11

With this code the watchdog triggers even for (continuous) loops that are due to programming. Regarding user program cycle time, please note the following:



With cycle times longer than 200 ms, the code sequence must be repeated multiple times in the user program in order to prevent the watchdog triggering during RUN.

12 Communication ports

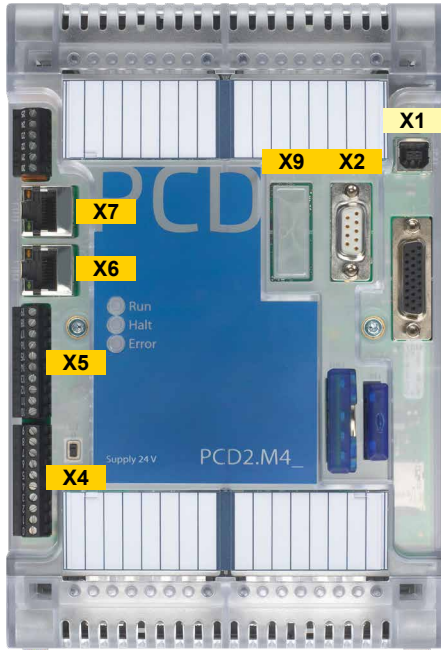

Terminal	Portnumber (Software-address)	Description
X1	PGU	Programming
X2	Port #2 Port #10	S-Bus, free protocol Profi S-Net
X4	Port #0	Integrated RS-485 terminal
X5	Port #1	Slot A interface selectable with PCD7.F1xxS
X6	Port #9	Dual Ethernet Switch
X7		
X9	Port #8	Profibus-DP with PCD2.F7500

12.1 X1 - USB Port (Programming Interface)

12

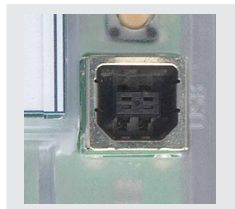

Plug:	Standard vertical USB series B (device plug)
Default:	USB 1.1 device (slave), full speed 12 Mbps, with Softconnect
Protection:	transil
Hardware:	On-board USB 5V supply

The USB port is only used as a PGU interface. To use the USB interface, the program package Saia PG5® version 2.0 or later must be installed on the PC.

If the PCD is connected to the PC for the first time through the USB port, the PC operating system (Windows) automatically loads the corresponding Saia PCD® USB driver. To connect the PCD via USB, the following setting is required in the Saia PG5® project folder for the device concerned under “Online settings”:

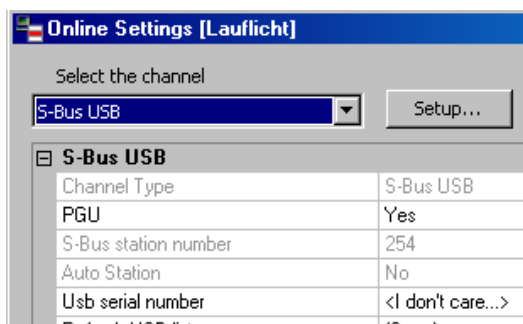

Activating the “PGU option” ensures that the PCD connected to the PC can be reached directly, independently of the configured S-Bus address.

12.2 X2 – Isolated RS-485-Port/MPI

9-pole D-Sub-terminal (Port #2)

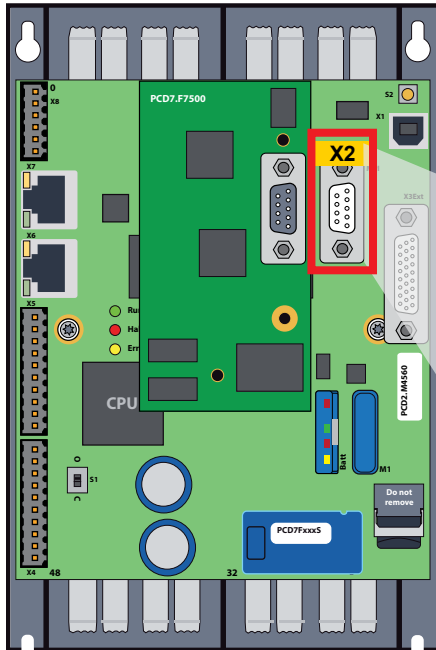

Can be used as MPI interface or as standard S-Bus RS-485.

S-Net/MPI/RS-485			
	D-Sub-Pin	Signal	Explanation
	1	PGND	GND
	2	GND	0 V from 24-V supply voltage
	3	RxD/TxD-P ¹⁾ B (rot)	Receive/send data, positive pole
	4	RTS/CNTR-P	Control signal for repeater(direction control)
	5	SGND ¹⁾	Data communication potential (Erde an 5 V)
	6	+5 V ¹⁾	Supply voltage for P-line terminating resistors
	7	MPI24V	Output voltage +24 V
	8	RxD/TxD-N ¹⁾ A (grün)	Receive/send data, negative pole
	9	Not used	

12

1) For Profibus mandatory signals (must be provided by the user). Specially the both signals SGND and +5V are provided by the PCD, if the Profibus configuration is correct.



► Further details can be found in the manual «26-740 Installations-Components for RS-485 Networks».

12.4 X5 - Sot A (Port #1) Terminalbloc

The interface type can be selected using the PCD7.F1xxS modules..

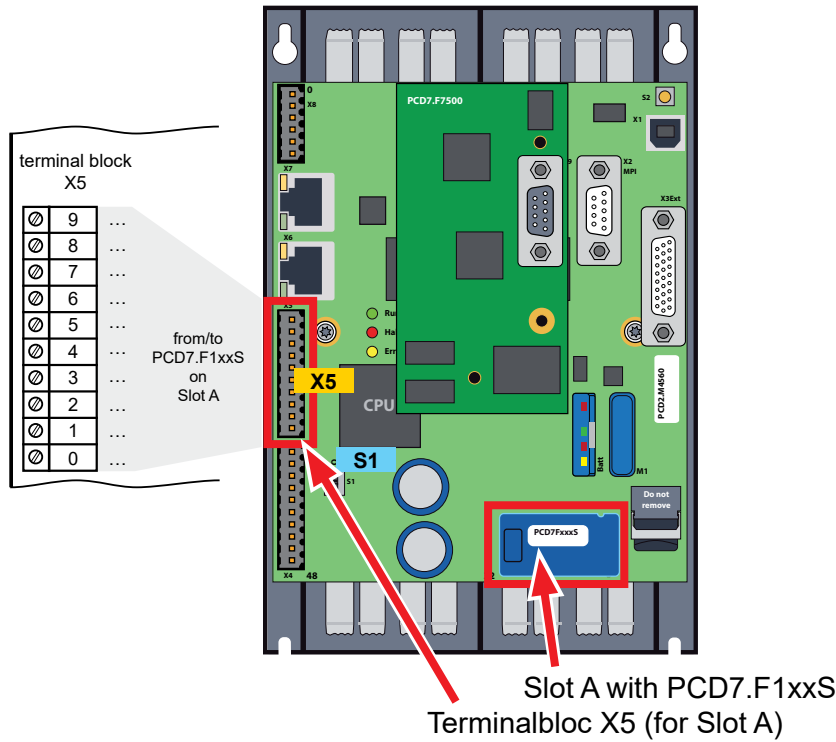

- ▶ Older interface modules without “S” at the end of the product designation (e.g. PCD7.F110) are not compatible with PCD2.M4x60.

Overview of the interface types:

PCD7.F1xxS with housing, 2012 or later

PCD7.F1xxS, previous design

PCD7.F1xx not compatible with PCD2.M4x60

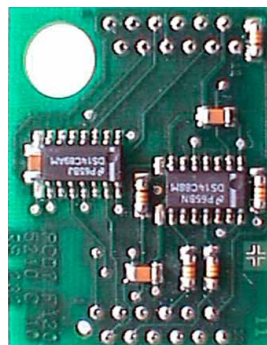
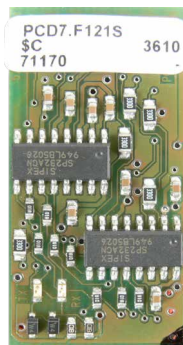

- ▶ **Important:** PCD7.F1xxS devices with hardware version A are not compatible with earlier PCDs (PCD1.M1xx/PCD2.M1xx/PCD2.M48x/PCS1) from NT-based PCD systems.



- ▶ Pin assignments, module variants and their functions can be found in the manual „27-664_Manual_PCD7.F1xxx“.

12.5 X6 and X7 - Ethernet Switch Port #9

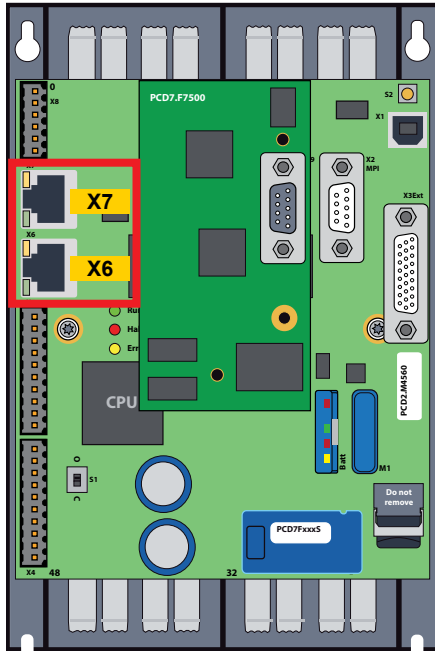

- ▶ A 10/100 Mbits switch on X6 and X7 is used for the Ethernet connection, which automatically adapts to the two speeds.
- ▶ The two sockets with the same Ethernet address can be used independently of each other in terms of speed.
- ▶ Data transfer and programming or debugging are possible without restrictions.



Function	2 Port Switch	
Socket type	RJ45, metal housing, 2 LEDs	
LEDs	yellow	Link and activity
	green	Speed Off = 10 Mbits / On = 100 Mbits
Port #	9	
Wiring	Standard Ethernetcabel (f.e. Cat 5e) un-crossed and crossed is supported.	



- ▶ It is advisable to discuss with the network responsible technician whether an undesired network load might occur. Depending on the application program, a PCD behaves differently in terms of communication (Traffic) than, for example, an office computer.
- ▶ In any case, it is recommended to create a separate PLC network.

12.6 X9 - Slot C Profibus-DP-Master (Port #8) optional

Profibus-DP master can be upgraded by retrofitting the PCD7.F7500 module to enabled Slot C .

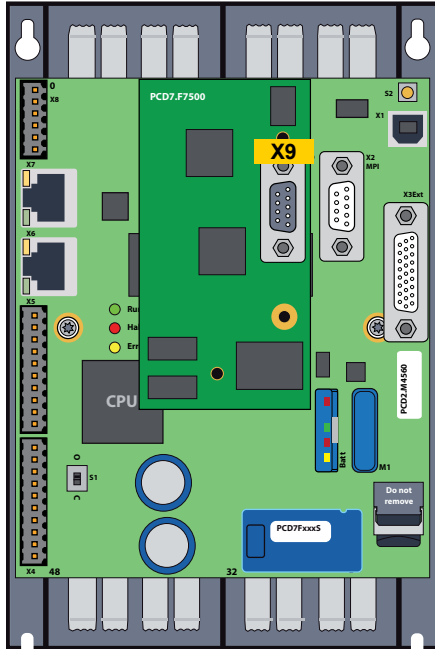

Anschluss	Slot
X9 D-Sub 9 pole (feminine)	C
MBit/s	12
PG5 port adress	#8

Pin Nr.	Signal
1	
2	
3	RxD/TxD-P B (rot)
4	RTS/CNTR-P
5	DP GND
6	DP +5 V
7	CAN_High
8	RxD/TxD-N A (grün)
9	
threaded bolts	PGND

PCD7.F7500 Profibus-DP-Master pluggable to PCD2.M4560 «Slot C»

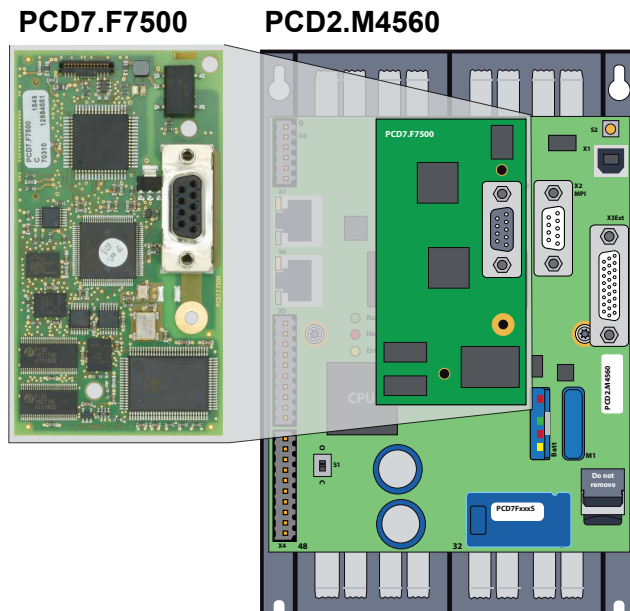

- ▶ To avoid reflections, each segment must be terminated at the ends of the cable. According to the Profibus standard, this must not be done on the device. The PCD7.T160 termination boxes or standard 9-pole Profibus DP D-Sub connectors are suitable for this purpose.



- ▶ Details can be found in the manual “26- 765 Profibus DP”.

Mounting on slot C

- Remove the power supply from the PCD2.M4_.
- Remove all cables (USB, Ethernet, Profibus, RS-232) that may be present and that may interfere with the removal of the housing.
- Remove the upper part of the housing.
- Next, insert the spacer supplied (Fig. 2) on the back of the PCD2.F7500 to be attached. The round end of the spacer must be inserted into the round hole of the CPU board.

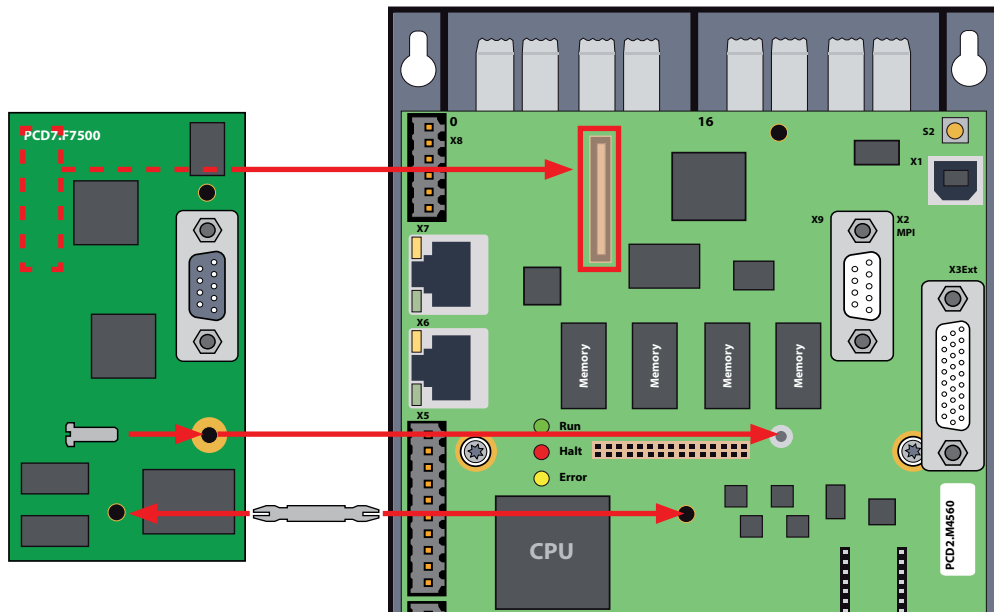

Fig. 1

Fig. 2

Fig. 3

12

- When plugging the spacer into the multi-board connector, make sure that it snaps into the round hole (Fig. 3) provided on the CPU board!
- Screw in the Torx T10 screw supplied to secure it on the pre-assembled spacer with screw thread.

- Process the upper part of the housing as follows:

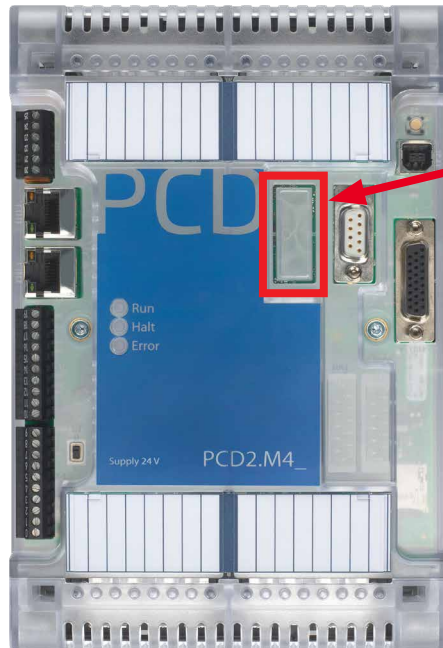

Pre-punched recess in the cover, break out the cut-outs on the left of the two D-Sub plugs.

Put on the upper part of the housing and secure it with the two Torx screws.

12.7 I/O module based interfaces PCD2.F2xxx

Two further serial interfaces allow the use of special I/O modules PCD2.F2xxx on suitable I/O slots.

The modules of type PCD2.F2xxx are intended for the inclusion in the I/O slots 0...3 of the PCD2.M_.

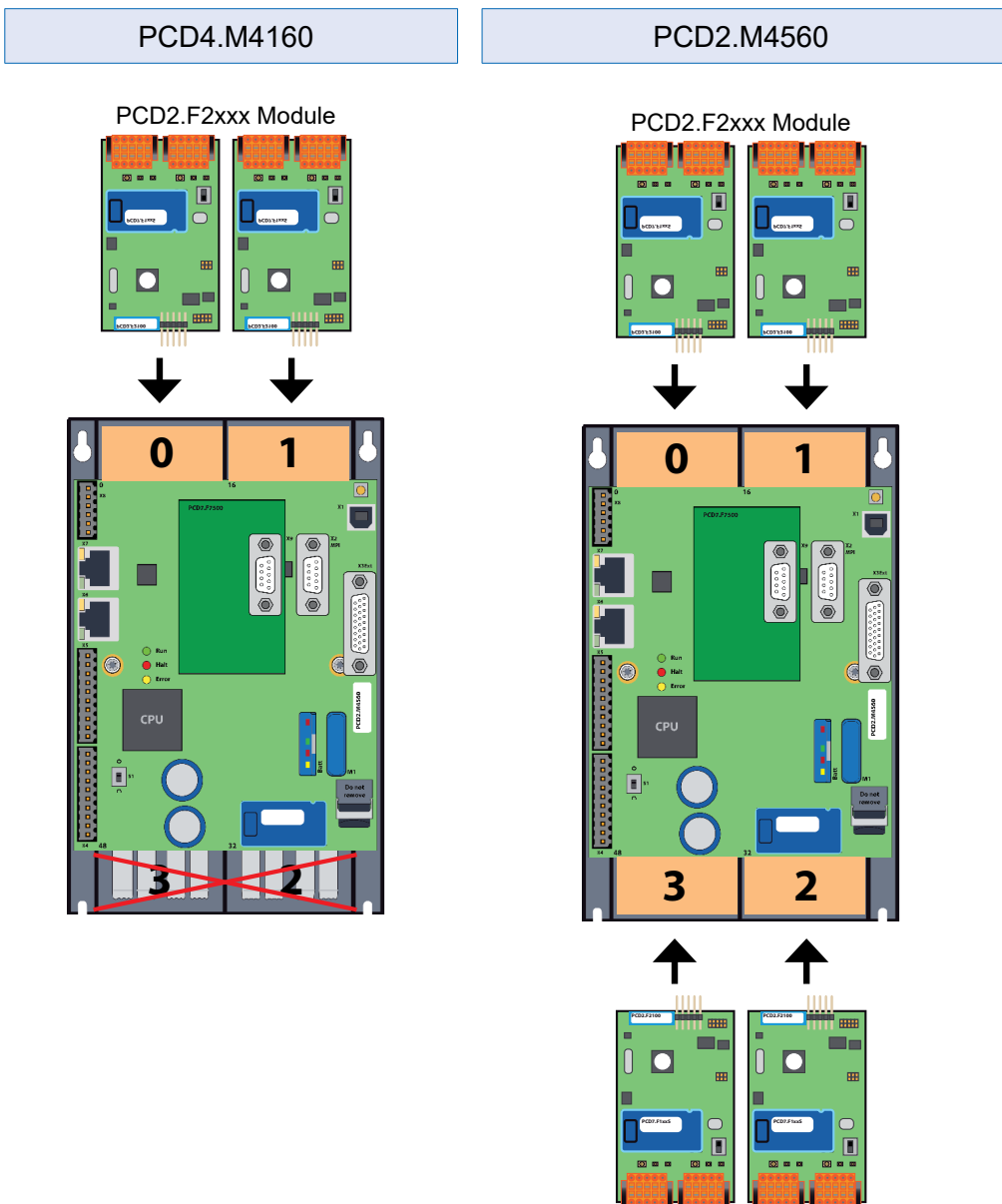
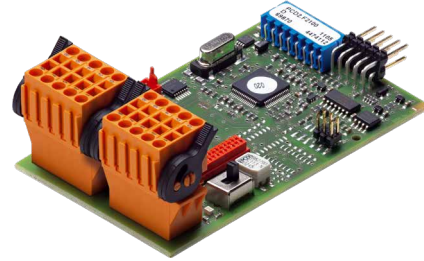

► How the CPU load behaves with the total number of communication ports used is described in the manual “27-649 Manual PCD2F2xxx” under “General information on the PCD2.F2xxx”.

Further documents on the subject of communication are recommended as supplements:

Thema	document number
System Catalog (serves as an overview)	26-215
Programming tool Saia PG5®	26-732
Programming by instructionlist	26-733
Ethernet-TCP/IP	26-776
RS-485 networks / components	26-740
Serial interface module PCD7.F1xxx	27-664
I/O based interface module PCD2.F2xxx	27-649

13 Dimensions

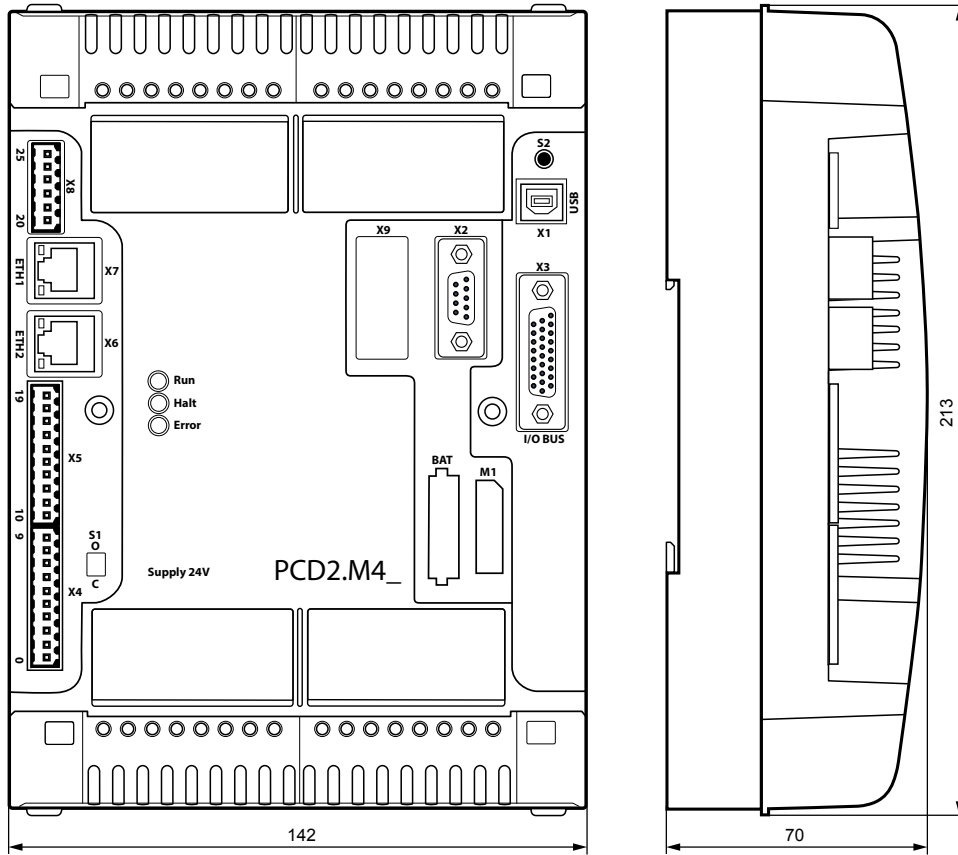

14 Mounting

There are 2 different types of installation:

mounted with screws

snapped on 2 DIN rails

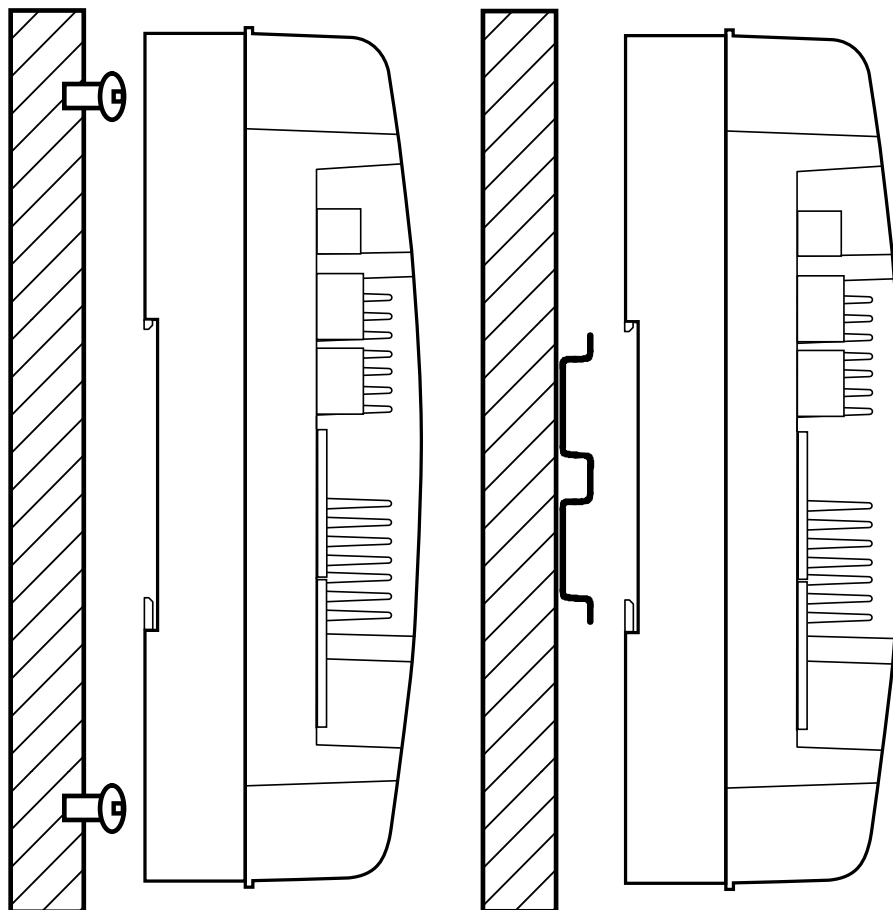

14.1 Mounting with screws

Screw diameter: less than $\varnothing 4.9$

Screw head diameter: less than $\varnothing 8.0$

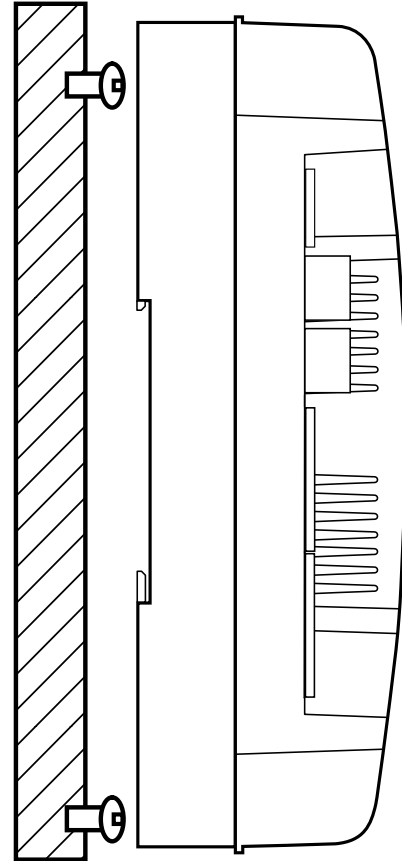
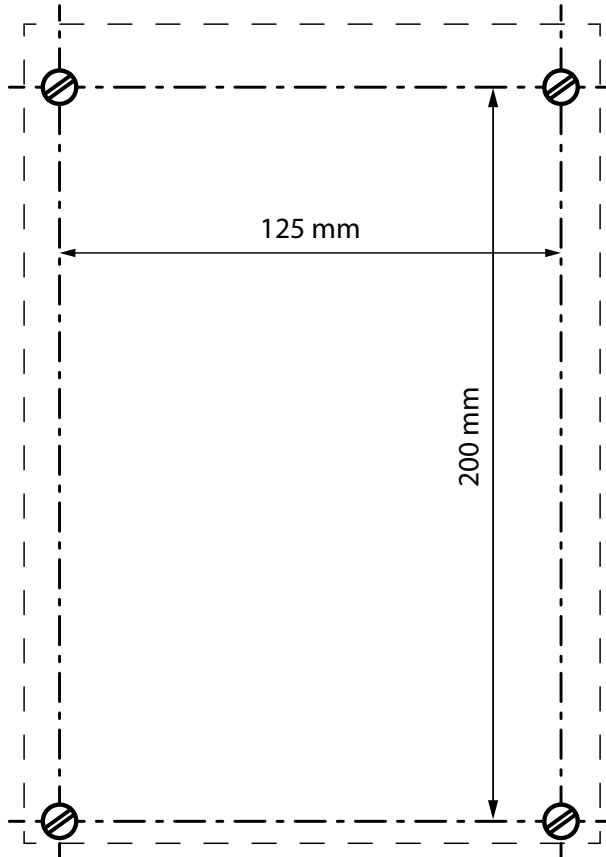

14.1.1 Mounting the PCD2.M4x60 and PCD2.C1000:

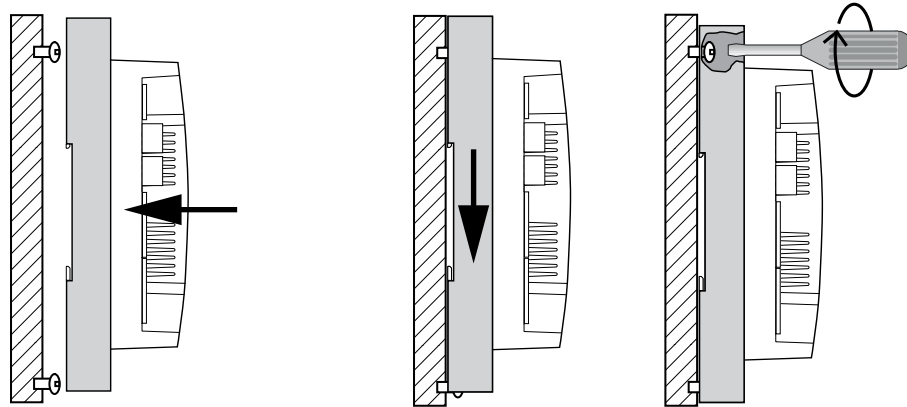

Step 1
Fit the base plate over the screw heads and press gently to the wall

Step 2
Slide bottom panel downwards

Step 3
Tighten the screws

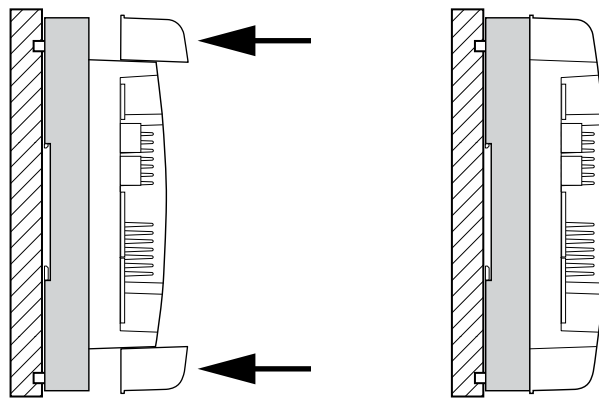

Step 4
Snap lid onto base plate

Step 5
Fixed

14.1.2 Dismounting the PCD2.M4x60 and PCD2.C1000:

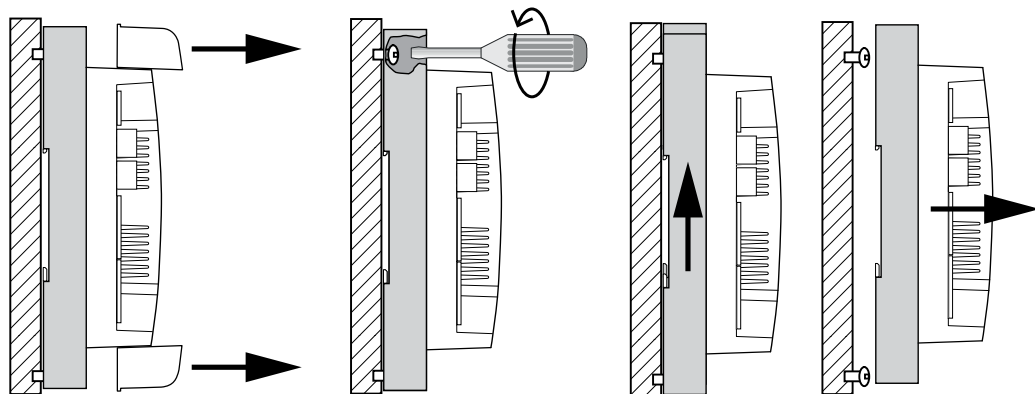

Step 1
Remove the cover

Step 2
Loosen the screws

Step 3
Push the base plate upwards

Step 4
Lift the base plate

14.2 DIN rail mounting

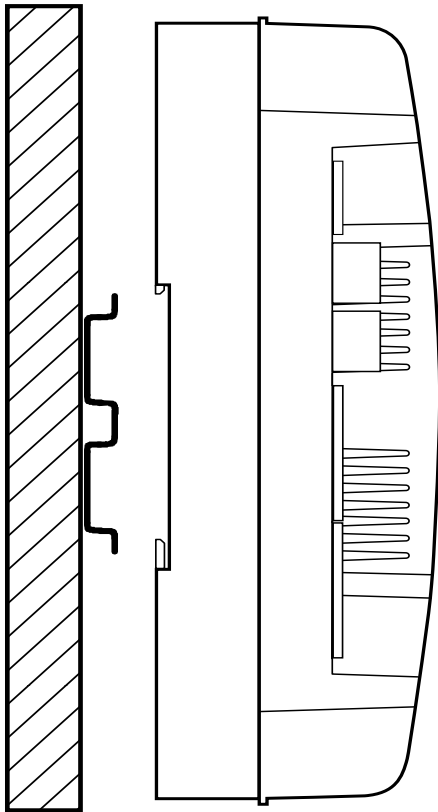

14.2.1 Mounting the PCD2.M4x60 and PCD2.C1000:

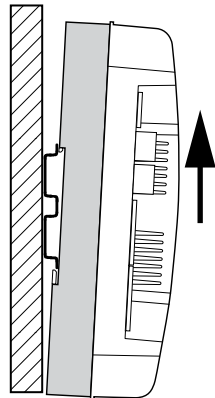

Step 1

Press the bottom of the module to the wall and slide it slowly upwards until it stops at the lower DIN rail

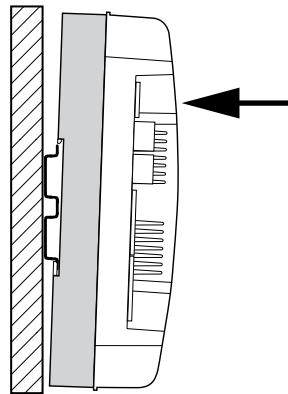

Step 2

Now press the upper half towards of the wall until it snaps

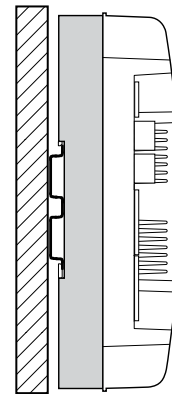

Step 3

Fixed

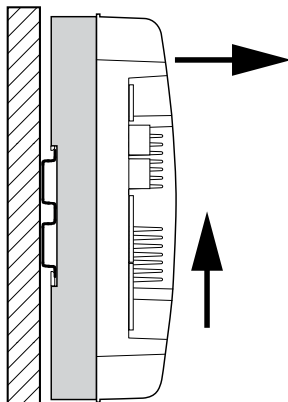

14.2.2 Dismounting the PCD2.M4x60 and PCD2.C1000:



Press the module upwards and simultaneously pull the upper half of the module from the wall

A Annex

A.1 Icons

	In manuals, this symbol refers the reader to further information in this manual or other manuals or technical information documents. As a rule there is no direct link to such documents.
	This symbol warns the reader of the risk to components from electrostatic discharges caused by touch. Recommendation: Before coming into contact with electrical components, you should at least touch the system's negative pole (cabinet or PGU connector). However, it is better to use a grounding wrist strap with its cable permanently attached to the system's negative pole.
	This sign accompanies instructions that must always be followed.

A.2 Waste of Electrical and Electronic Equipment (WEEE) disposal

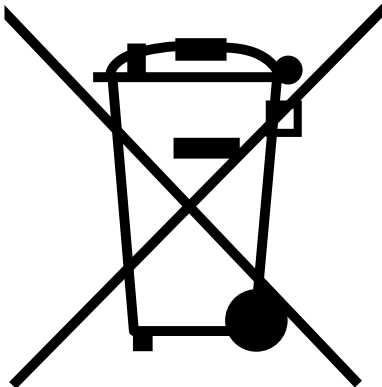

WEEE Directive 2012/19/EC Waste Electrical and Electronic Equipment directive

This symbol on our product shows a crossed-out “wheelie-bin” as required by law regarding the Waste of Electrical and Electronic Equipment (WEEE) disposal. This indicates your responsibility to contribute in protecting the environment by proper disposal of this waste, i.e., not disposing of this product with your other wastes. To know the right disposal mechanism, please check the applicable law.”

A

A.3 Contact

Saia-Burgess Controls AG

Bahnhofstrasse 18
3280 Murten, Switzerland

Phone central..... +41 26 580 30 00

Phone Saia-PCD Support..... +41 26 580 31 00

Fax..... +41 26 580 34 99

Email support: support@saia-pcd.com

Supportsite: www.sbc-support.com

SBC site: www.saia-pcd.com

International Representatives &

SBC Sales Companies: www.saia-pcd.com/contact

Postal address for returns from customers of the Swiss Sales office**Saia-Burgess Controls AG**

Service Après-Vente
Bahnhofstrasse 18
3280 Murten, Switzerland