

# Honeywell

MAXON

## OVENPAK® 400 Gas Burners

INSTRUCTION MANUAL

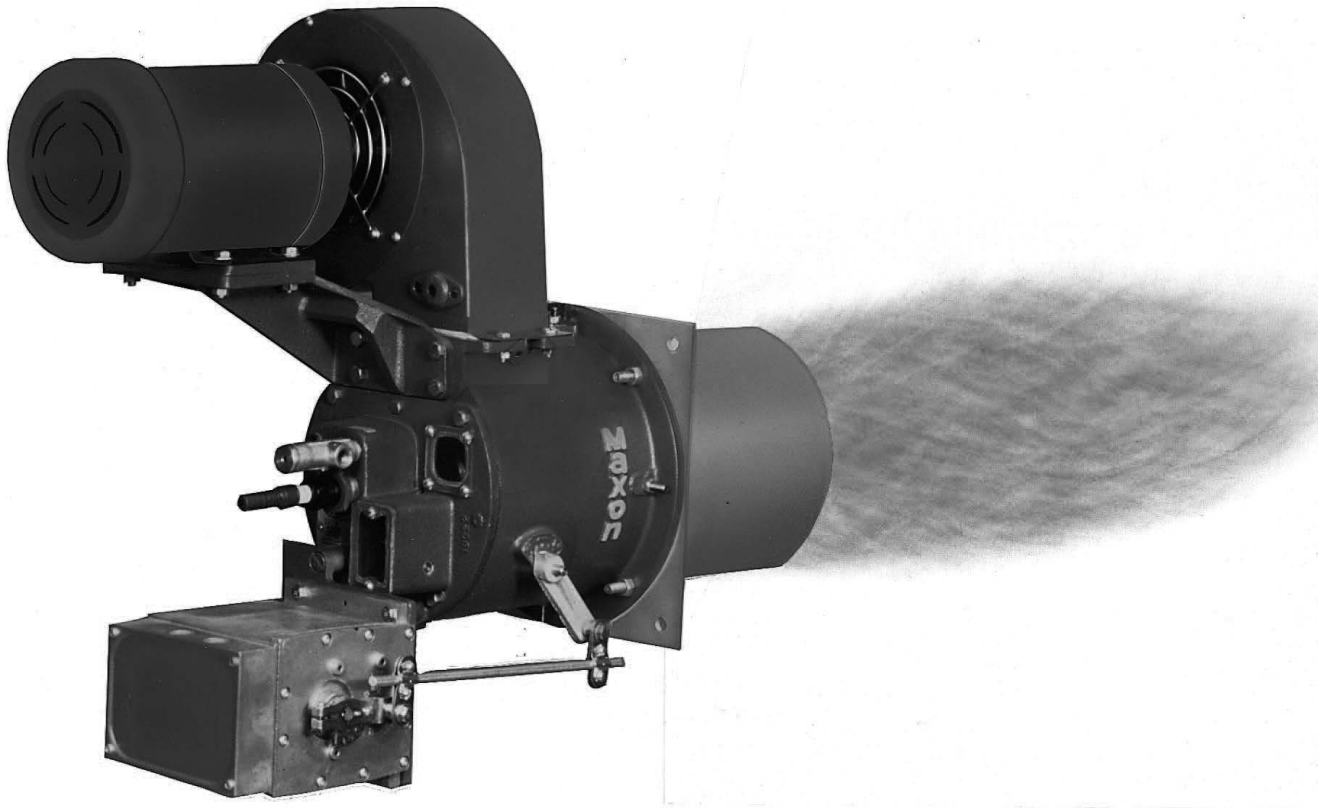

### INSTALLATION INSTRUCTIONS

#### General Instructions

**IMPORTANT**

*Do not discard packing material until all loose items are accounted for.*

To prevent damage in transit, the oil flowmeter, spark ignitor, discharge sleeve, mounting gaskets, flame rod and connecting linkage components may be packed separately and shipped loose with your new MAXON OVENPAK® Burner.

The burner itself is normally only a part of your complete combustion system. Additional pipe train accessories and control components will be required for a complete system installation. The sketch below shows a typical gas train as might be used with OVENPAK® gas fired burners.



32M-91002-01

## Piping Layout as sometimes required by insurance and standards groups

### Block and Bleed gas train arrangement illustrated with Model "400" OVENPAK® Burner

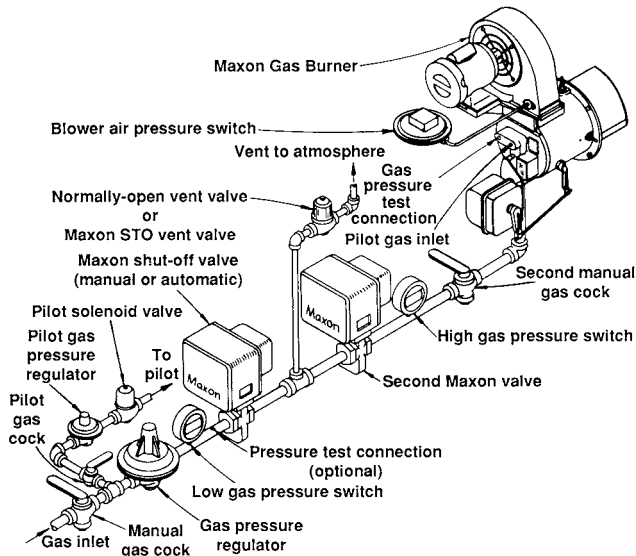

Model "400" OVENPAK® Burners provide the air supply (except for EB versions, which require a separate combustion air blower). They also serve as a fuel flow control and fuel/air mixing device.

Burner should not be exposed to direct radiant heat or positioned where it might draw in inert gases. If such conditions exist, consider filters, relocation and/or use of the EB version and external air supply.

Electrical service must match the voltage, phase and cycle of all electrical system components and be compatible with burner nameplate ratings. Insure that all normal control safeguards are satisfied. Combustion air blower should continue to run after shutdown to allow burner to cool.

Gas supply piping must be large enough to maintain the required fuel pressures cataloged for the particular burner size used with burner operating at full rated capacity.

Anything more than minimal distance or piping turns may necessitate oversizing piping runs to keep pressure drops within acceptable ranges.

Inlet pipe leading to any burner should be at least four pipe diameters in length. If multiple burners are fed from a single gas train, care should be taken to minimize pressure drop and give maximum uniformity.

Clean fuel lines are essential to prevent blockage of pipe train components or burner gas ports.

Main Shut-Off Cock should be upstream of both the main gas regulator and pilot line take-off. Use it to shut off fuel to both pilot and main burner during shutdown periods of more than a few hours.

The fuel throttling valve contained within a MAXON burner is not intended for tight shut-off.

Main gas regulator is essential to maintain a uniform system supply pressure. If one pipe train supplies multiple burners, provide a separate regulator in the branch leading to each burner system.

Size the regulator for full system capacity at the required pressure, carefully considering pipe train losses. Follow the instructions attached to the regulator during installation and be sure to remove any shipping pin or block.

Pilot take-off should be upstream of the main gas regulator, but downstream of the main gas cock. It should normally include its own pilot gas regulator, a solenoid valve and shut-off cock. A pilot adjustable orifice at the pilot inlet simplifies adjustment.

Pilot piping must be large enough to provide for the full flow and pressures shown in the catalog for your particular burner size.

Fuel Shut-Off Valves (when properly connected to a control system) shut the fuel supply off when a hazardous operating condition is sensed. Manual reset valves require operator attendance each time the system is started up (or restarted after a trip-out). Motorized shut-off valves permit automatic start-restart when used with an appropriate control system.

Test connections are essential for burner adjustment. They should be provided immediately downstream of the regulator and are included in the burner itself. Test connections must be plugged except when readings are being taken.

Horizontal mounting is preferred, but burner may be mounted in any position suitable for automatic control motor and UV scanner (if used).

OVENPAK® Burners will typically be installed through an oven wall or insulated air duct. Cut opening approximately 1" larger in diameter than discharge sleeve to allow for thermal expansion of sleeve.

Burner mounting requires four studs and a flat mounting surface perfectly centered on the discharge sleeve.

After placing burner in position over studs, add lock washers and nuts, then draw up hand-tight only.

Check that burner is seated evenly all around the flange, filling any gaps to prevent air leakage, then tighten all nuts firmly.

For proper performance of any burner, air inlet and motor should be surrounded by clean, fresh, cool air.

Burner and pipe manifold support will be required to support weight of the burner and connected pipe train components. Air control motors, in particular, require additional support. MAXON connecting base and linkage assemblies are designed to position the control motors to work with the burner, not to support their weight.

The Packaged Model “400” OVENPAK® Burner requires external auxiliary support provided by the user. The support configuration may be similar to the leg support or knee bracket support illustrated below.

Suggested supporting arrangements for Packaged Model “400” OVENPAK® Burners:

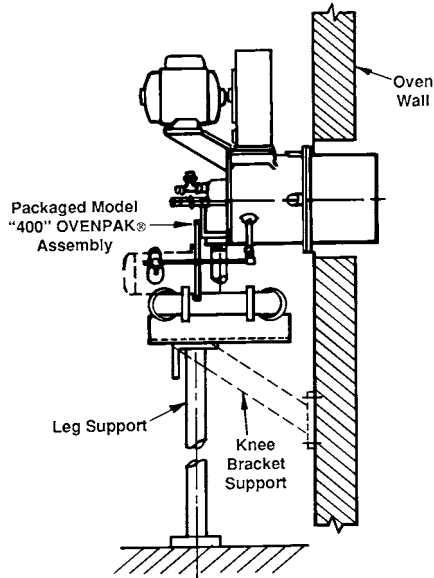

Additional burner support may be required in conjunction with a stiffener plate when mounting OVENPAK® Burner (weighing 100-350 pounds) through typical thin wall of heater/oven panels.

For push-through systems, use MAXON special back pressure gasket between stiffener plate and discharge sleeve flange and use (2) ring gaskets between discharge sleeve flange and burner casting to prevent back flow of high temperature air. Fill area D (see sketch below) with no more than 2" of high temperature packing (too little will overheat mounting; too much will overheat sleeve).

## Typical discharge sleeve mounting recommendations

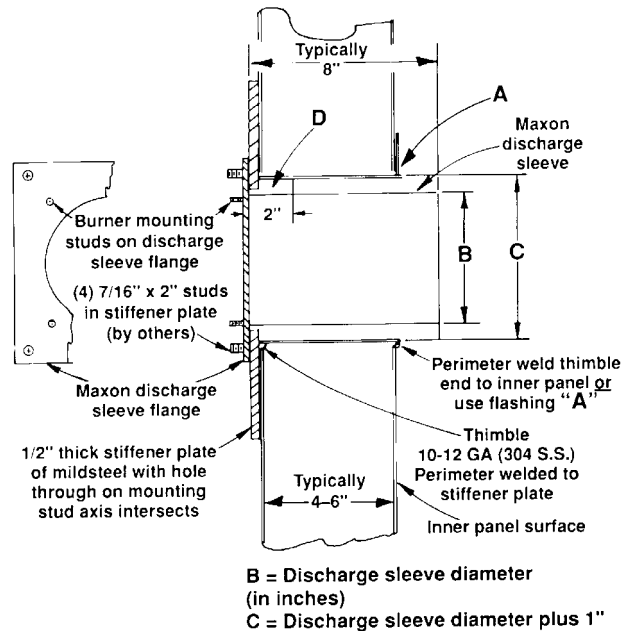

For pull-through systems, spacers may be installed on stud bolts and area D left empty to admit cooling air past the sleeve.

## ⚠ WARNING

**Welding of burner flange to stiffener plate may cause warpage of burner flange and require additional seal material to prevent leakage.**

Four lock screws permit centering of mixing cone within burner body and sleeve.

Lock screws should be drawn up hand-tight, then backed out one-half turn to allow for cone expansion. They must be re-checked after start-up, and loosened if necessary to prevent deformation of cone. See start-up instructions for details. Over-tightening lock screws can lead to cone distortion and greatly reduce cone and discharge sleeve life.

Discharge sleeve must be flush with, or extend beyond, interior wall. MAXON can supply a special 12" long discharge sleeve, but higher noise levels may result, particularly when firing on propane.

An external viewing port should be provided for flame observation, preferably in such a position that burner pilot and main flame can both be seen.

Flame sensing can be accomplished by either flame rod or UV scanner. When UV scanner is used, it should be kept as close to burner as feasible. Heat block, if used, may affect signal strength with some brands of scanners.

Field conversion from a flame rod version to a UV scanner version and vice versa may require additional parts in the burner. Contact MAXON for requirements.

Alternate fuels may require correction of supply pressures.

If OVENPAK® Burner is equipped with MAXON Hi/Lo Control Motor, low-fire start wiring can be accomplished as shown in the sketch below.

MAXON assumes no responsibility for the use or misuse of the layouts shown. Specific piping and wiring diagrams should always be submitted to the appropriate agencies for approval on each application.

Multi-burner installations require special considerations if supplied by a common pipe train and/or air supply. Air and Gas Balancing Valves should be used for improved heating uniformity; Gas Swing-Check Valves should be installed as close as possible to each burner inlet for dependable lightoff (gas manifold may otherwise act as a reservoir, preventing lightoff during trial-for-ignition period).

Control system's circuitry must not allow main Fuel Shut-Off Valve to be opened unless combustion air is on, and must de-energize valve upon loss of combustion air pressure, along with the other usual system interlocks. Motor starter is to be interlocked with valve, whether or not a combustion air pressure switch is used.

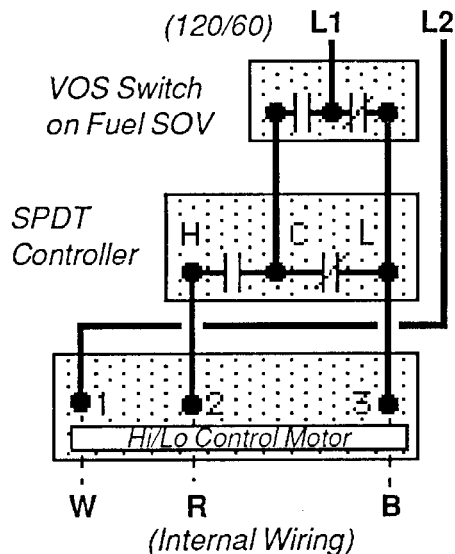

## START-UP INSTRUCTIONS

Read complete instructions before proceeding, and familiarize yourself with all the system's equipment components. Verify that your equipment has been installed in accordance with the original manufacturer's current instructions.



### CAUTION

**Initial adjustment and light-off should be undertaken only by trained and experienced personnel familiar with combustion systems, with control/safety circuitry, and with knowledge of the overall installation.**

Instructions provided by the company and/or individuals responsible for the manufacture and/or overall installation of complete system incorporating MAXON burners take precedence over those provided by MAXON. If MAXON instructions conflict with any codes or regulations, contact MAXON Corporation before attempting start-up.

### For initial OVENPAK® Burner start-up:

1. Close all burner fuel valves and cocks. Make preliminary adjustments to fuel gas regulators. Remove pilot and main gas regulator's adjusting screw covers. Turn adjusting screw down (clockwise) to approximately mid-position. Close pilot gas adjustable orifice screw by turning in clockwise until it stops. (Do not over-tighten.) Then back out the adjustable orifice (counter-clockwise) approximately 2-3 turns.
2. Check all electric circuitry. Verify that all control devices and interlocks are operable and functioning within their respective settings/ranges. Be sure all air and gas manifolds are tight and that test ports are plugged if not being used.
3. Check that all duct and chamber dampers are properly positioned and locked into operating positions.
4. Disconnect the automatic control motor's linkage arm from the "400" OVENPAK® Burner's operating crank arm by loosening the control motor's connecting rod from the burner's toggle linkage. For Model EB-MRV, the connecting linkage on the separate control valve must be similarly loosened and disconnected. Refer to specific adjusting procedures relating to control valve adjustment in MAXON catalog. Initial start-up adjustment should only be accomplished during a manual burner control mode.
5. Start all system-related fans and blowers. Check for proper motor rotation and impeller direction. Verify that all control interlocks are working. Allow air handling equipment to run for adequate purge of your manifolds and combustion chamber plenums. With main gas shut off, manually advance burner to high fire position so that air only flows through burner and combustion chamber.



## CAUTION

Do not by-pass control panel timers typically controlling sequential operations.

### For EB OVENPAK® Burners only (step 6)

- Verify differential air pressure. With combustion air blower on, all volume air fans operating, and burner at high fire position, connect a manometer between the air test connection on backplate of OVENPAK® Burner and your combustion chamber static pressure test connection. This will give a direct differential air pressure reading.

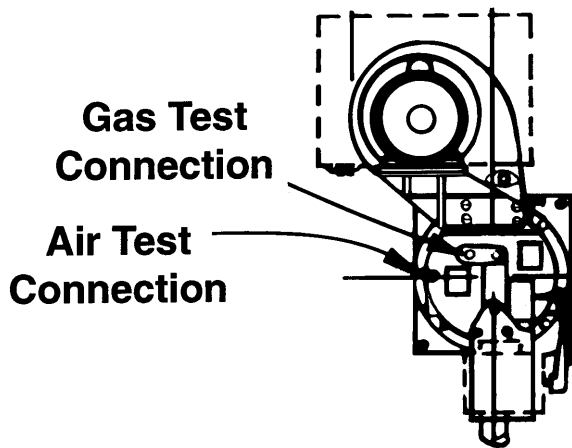

Determine your differential air pressure reading by taking an additional reading with manometer connected between the burner's air pressure test port and atmosphere with the burner at high fire position, fuel valves closed, and all air handling systems running. Subtract the combustion chamber static pressure obtained above from this air pressure reading to give you differential air pressure reading.

The differential air pressure setting determines the burner's capacity and performance capabilities. Model EB and MA manual air OVENPAK® Burners, with their external air control valve(s), provide for the manual setting of this differential air pressure to the burner. Refer to specific adjusting procedures relating to MICRO-RATOR and control valve adjustment in MAXON product line catalog. MA OVENPAK® Burners have an external locknut adjustment on the end of the air butterfly control valve. This lets you limit and set the differential pressure to the OVENPAK® Burner. Refer to MAXON specification tables in the catalog for the differential air settings required for your specific OVENPAK® Burner capacity.

- Determine the required differential gas pressure using this differential air pressure reading obtained from step 6. If your combustion chamber does not have a static pressure test connection, then you must measure combustion chamber static pressure by connecting a manometer between the gas pressure test port on the burner's backplate and to atmosphere with the

burner at low fire position, fuel valves closed, and all air handling systems running. High fire pressures are provided in MAXON product line catalog literature and/or read data stamped into burner nameplate.

- Verify that spark ignitor is properly positioned and lines up with the appropriate dimensions required for your specific burner. (Refer to appropriate MAXON catalog specification table.) Check that spark ignitor arcs at the end of your properly positioned ignitor.
- Return burner control valve (or crank) to low fire position when purge of system is complete.
- Open main and pilot gas cocks, then attempt spark ignition to light pilot while slowly turning pilot gas regulator spring clockwise and/or adjustable orifice screw counter-clockwise to increase fuel flow. Repeat procedure as necessary until pilot ignites as air might have to be bled out of fuel supply lines before reliable pilot flame is established. Pilot gas regulator should normally be set for as low a pressure as possible, using fuller opening of pilot gas adjustable orifice (if used).
- After ignition, adjust pilot flame for good stable flame shape. A rule of thumb is that any pilot over a tennis ball size is probably too large. This assumes you have visual access to the pilot flame. If this is not possible, then adjust pilot to give the strongest and most stable flame signal through your flame safety circuit. This signal strength can be read with a micro-amp meter. The signal strength (or range) will be determined by the specific type of flame safeguard instrument you have with your burner system.
- Re-check pilot ignition by closing pilot gas cock or otherwise causing pilot outage. Re-light and refine pilot gas adjustment as necessary to get ignition within a second or two. The flame safeguard relays should now power your main fuel Shut-Off Valve(s).



## CAUTION

After completing steps above, recheck all interlocking safety components and circuitry to prove that they are properly installed, correctly set, and fully operational.

If in doubt, shut the system down, close pilot cock and contact responsible individual before proceeding further.

- Establish main flame. With burner at low fire position, back out main gas pressure regulator adjusting screw (counter-clockwise) to get lowest outlet pressure possible. Open all manual fuel shut-off valves (automatic fuel shut-off valve should already be open) so gas flows to burner inlet. There should be little, if any, change in flame appearance. Turn main regulator adjusting screw in (clockwise) to obtain outlet pressure of about 4"-6" wc higher than combustion chamber pressure (2"-4" wc for propane, considerably higher for some EB versions). Main flame should now appear larger than pilot-only flame.
- Establish high fire setting by slowly moving burner toward high fire position while observing gas pressure at burner gas test connection. Refine main gas regulator adjustment as necessary to provide correct differential pressure (gauge to combustion chamber, see step 7) at high fire. If pressure cannot be adjusted low enough, a different regulator or regulator spring may be necessary, or a limiting orifice valve (such as

MAXON's Series "BV") should be added. Do not, however, exceed 4" wc pressure drop between regulator outlet and burner inlet.

 **CAUTION**

**If burner(s) go out, close shut-off valve or shut main gas cock at once.**

Return to minimum setting, re-light pilots if necessary, then turn main gas on again. Check carefully that every burner is lit before proceeding.

Cycle burner from minimum to maximum and refine adjustment, if necessary.

For operation with interrupted pilot (as recommended), shut off pilots and cycle burner from minimum to maximum and back several times to verify the flame is maintained.

15. When burner performance is satisfactory and stable throughout the firing range, reconnect control motor. Reconnect linkage to control motor. Control linkage travel must be such that burner crank is moved throughout its complete travel, or cataloged capacities and turndowns will not be achieved. If less than full-rated burner capacity is required, linkage can be adjusted to limit maximum output.

With interrupted pilot, it may be necessary to set control for somewhat higher than minimum burner setting to permit hold-in of flame detection system without pilot.

 **CAUTION**

**Internal drive mechanism within the control motor may be damaged if linkage is adjusted so as to cause binding with burner in high or low fire position.**

16. Re-check differential gas pressure with unit at operating temperature. Refine high fire setting if necessary, considering differential pressure, flame length, and appearance. Natural gas flame should normally be predominantly clear blue but possibly with semi-luminous tips. Dust or contaminants in the air stream may affect flame appearance.

17. Check for contact between mixing cone and top-most centering screw after system has reached maximum operating temperature. If set screw touches cone, back off an additional 1/8 turn on top and both side set screws.
18. Plug all test connections not in use to avoid dangerous fuel leakage. Replace equipment cover caps and tighten linkage screws.
19. Check out overall system operation by cycling through light-off at minimum, interrupting pilot, and allowing temperature control system to cycle burner from minimum to maximum and return. Recheck all safety system interlocks for proper setting and operation.

NOTE: Typical gas firing control sequence for MAXON burner is provided only as a guide. Instructions provided by complete system manufacturer incorporating MAXON burners take precedence.

**For gas firing Model "400" OVENPAK® Burner**

Light-off:

- a. Close cocks, shut-off valve(s)
- b. Verify burner at low fire
- c. Start recirculating/exhaust fans
- d. Start burner blower
- e. Purge at least 4 air changes
- f. Open pilot & main gas cocks

Shut-down:

- a. Close main & pilot gas cocks
- b. Keep combustion air blower running after shut-down long enough to allow burner to cool

 **WARNING**

**Test every UV installation for dangerous spark excitation from ignitors and other possible sources of direct or reflected UV radiation. Use only gas-tight scanner connections.**

20. Before system is placed into full service, instruct operator personnel on proper start-up operation with shut-down of system, establishing written instructions for their future reference.



**MAXON**

201 East 18th Street  
P.O. Box 2068  
Muncie, IN 47307-0068  
[www.maxoncorp.com](http://www.maxoncorp.com)

Maxon reserves the right to alter specifications and data without prior notice.

**Automation and Control Solutions**

Honeywell International Inc.  
1985 Douglas Drive North  
Golden Valley, MN 55422  
[customer.honeywell.com](http://customer.honeywell.com)

® U.S. Registered Trademark  
© 2016 Honeywell International Inc.  
32M-91002-01 M.S. Rev. 04-16  
Printed in United States

