

Series 300 OXY-THERM®

High temperature burners



- Capacities up to 300,000 Btu/h with choice of two block shapes.
- Burns any gaseous fuel, including poor quality fuels that may be unstable using air for combustion.
- Clean combustion with low NOx levels. OXY-THERM® burners use oxygen for the combustion reaction, removing atmospheric nitrogen as a source of NOx emissions.
- Easy installation and maintenance. OXY-THERM® burner nozzles can be removed during furnace operation, eliminating costly downtime.
- Dramatically increase efficiency by producing higher flame temperatures from burning fuels with oxygen.
- Substantially reduce the size of exhaust gas handling equipment. Oxygen-fuel firing can reduce flue gas volume and exhaust gas treatment requirements by 75% or more.
- Improve heat transfer with increased flame temperature and luminosity.
- Self-cooling design eliminates the need for water cooling and related water piping and maintenance.
- Simple, robust design and high operational turndown provides application flexibility.

Product description

With Series 300 OXY-THERM® burners, oxygen for combustion enters the burner body, mixes with the fuel at the nozzle and exits the burner block.

The flame discharges through the refractory block tunnel and develops a luminous, tightly-wrapped flame pattern.

The alumina/zirconia/silica (AZS) composition refractory block is available in both 3" (75.2 mm) square and 3" (75.2 mm) round versions.

The Series 300 OXY-THERM® burner features a direct spark option. Contact your MAXON representative about specific ignition questions.

Insulator block is included with direct spark option. If UV sensing is required with the direct spark option, UV scanner adapter should be ordered.

- 1) Block and frame assembly
- 2) Burner insert assembly
- 3) Backplate
- 4) Backplate gasket
- 5) M6 x 1.0 hex nut
- 6) Spring plunger
- 7) Insulator
- 8) Oxygen inlet 3/4" NPT
- 9) Gas inlet 1/8" NPT or 3/16" tubing

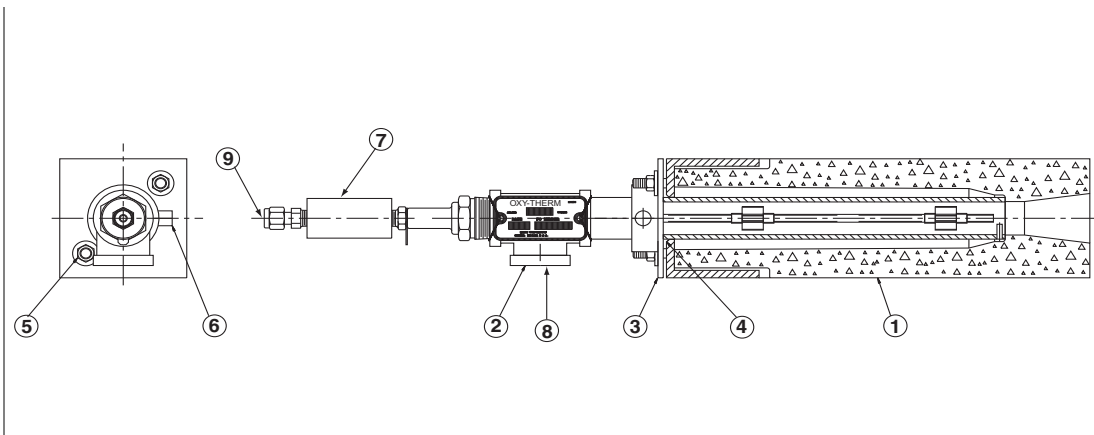

Available Series 300 OXY-THERM® burner sizes

| Typical burner data | | | |
|---|-----------------|------------|-----|
| Fuel: natural gas at 60°F with 1000 Btu/ft ³ (st) HHV - sg = 0.6 [1] | | | |
| Stated pressures are indicative. Actual pressures are a function of gas and oxygen quality and fuel type. | | | |
| OXY-THERM® Burners | | Series 300 | |
| Maximum capacity | Btu/h | 300,000 | |
| Minimum capacity [2] | Btu/h | 5,000 | |
| Turndown | | 60:1 | |
| Required pressures to burner inlet for maximum capacities | Oxygen flow | scfh | 630 |
| | Oxygen pressure | " wc | 2.9 |
| | Natural gas [3] | psig | 6.2 |
| | Propane [3] | psig | 2.5 |

[1] sg (specific gravity) = relative density to air (density air = 0.0763 lb/ft³ (st))

[2] Lower minimums are possible, if special considerations are taken. Contact MAXON for more information.

[3] Lower maximum pressures are possible if spark ignition feature is not required.

Applications

Typical applications include regenerative-type furnaces and melters, unit melters, laboratory furnaces, non-ferrous melting and recovery, flame treating, glass forehearths, and various applications requiring high temperatures with focused flame profiles.

Dimensions and weights

- 1) Removal clearance
- 2) Gas inlet (1/8" NPT)
- 3) 3/4" NPT oxygen inlet
- 4) Exterior furnace wall

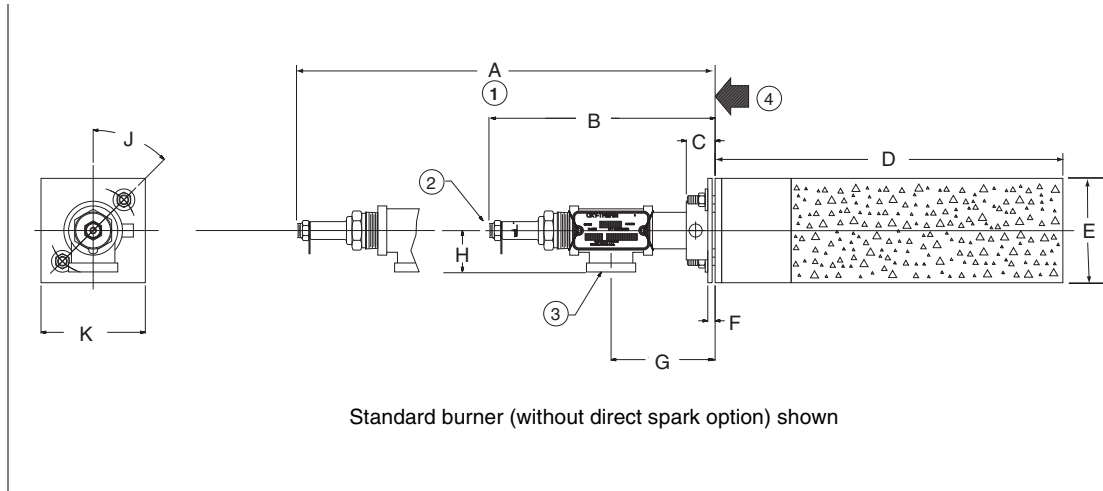

Dimensions in inches unless stated otherwise

| A | B | C | D | E | F |
|------|-----|-----|------|-----|-----|
| 16.5 | 6.5 | 0.8 | 10.0 | 3.0 | 0.2 |

| G | H | J | K square | Weight lbs |
|-----|-----|-----|----------|------------|
| 3.0 | 1.2 | 45° | 3.0 | 11 |

Typical emissions

Emission numbers are highly dependent on application. There can be a large variance in actual emissions due to the application's specific furnace conditions (i.e. nitrates in batch, air leakage into furnace, furnace temperature, etc.).

Read "Specifications of Series 300 OXY-THERM® burners" for correct and complete information on Series 300 OXY-THERM® burners.