

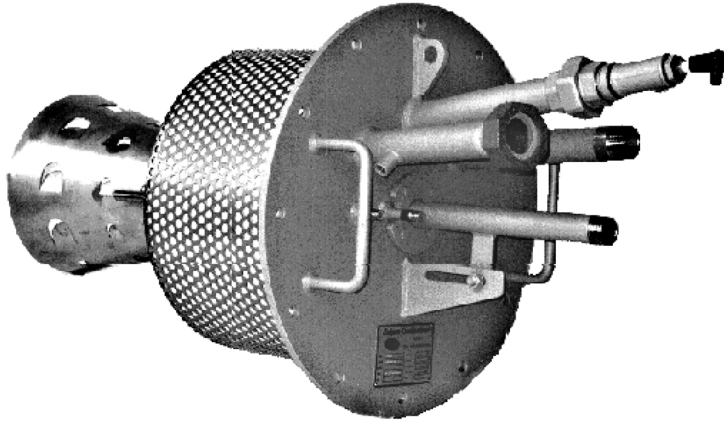

# Incini-Cone Burner

Model IC

Version 1.00



## **Warning:**

The burners covered in this Guide are designed to mix fuel with air and burn the resulting mixture. All fuel burning devices can produce explosions and fires when improperly applied, installed, adjusted, controlled, or maintained. This Guide provides information for using these burners for their limited design purpose.

Do not deviate from any instructions or application limits in this Guide without written advice from Eclipse Combustion. Read this entire Guide before attempting to light burners. If you do not understand any part of the information in this Guide, contact your local Eclipse representative or Eclipse Combustion before proceeding further.

Protection from the elements must be provided from the time the Incini-Cone burner leaves the Eclipse factory. Do not store outside. Rain, snow or temperature extremes may damage the burner. All maintenance and trouble shooting on Incini-Cone burners should be performed by people with good mechanical aptitude and experience with combustion equipment.

## **Important Notices About Safe Burner Operation**

1. Store the burner inside. Exposure to the elements can damage the burner.
2. Adjustment, maintenance, and troubleshooting of the mechanical parts of this unit should be undertaken by people with good mechanical aptitude and experience with combustion equipment.
3. Order replacement parts from Eclipse Combustion only. Customer-supplied valves or switches should carry local approval where applicable.
4. The best safety precaution is an alert and competent operator. Thoroughly instruct new operators so they demonstrate an adequate understanding of the equipment and its operation. Regular retraining must be scheduled to maintain a high degree of proficiency. The operator must have easy access to this Guide at all times.

Upon receipt: check the burner thoroughly during uncrating and before installation. Please contact Eclipse Combustion if any part seems broken or damaged.

## 1. Applications

Eclipse Incini-Cone Burners are gas and oil burners designed primarily for mounting in exhaust ducts where all of the combustion air flows through and by the burner.

These burners provide clean combustion throughout a fuel turndown range of 20 : 1. (depending on the gas gun selection).

They are well suited to applications requiring a clean, high destruction rate of volatile organic compounds, smoke and odors.

Do not use choke rings or other turbulence-inducing devices in downstream combustion chambers, they may cause erratic burner performance.

## 2. Flame monitoring

Flame monitoring must be provided by an ultra-violet scanner; (generally a self-check scanner as incinerators operate continuously). Flame rod monitoring is not acceptable.

Flame sensing equipment should be locally approved.

Refer to suppliers' information guides for specific details on the installation and use of flame monitoring equipment.



### Caution

*Failure to use suitable flame sensing devices and automatic fuel shutoff valves can cause violent explosions and fires. The owner, user and/or his insurance underwriter is responsible for providing, using, and maintaining suitable limit controls, flame supervision, and other safety devices for this burner, and for properly interfacing all electrical equipment and sequencing burner operation.*

## 3. Gas and purge air supply

The information in this guide is based on the use of valve trains and/or components shown in Figure 3. It is the customer's responsibility to supply gas to the inlet at the required pressure when using these valve trains or similar components.

The customer must supply an air source for the UV scanner and peepsight in the form of compressed air or other air sources as described in section 6. Purge air consumption is 2-3 Nm<sup>3</sup>/h. Required air pressure is 10 mbar above the incinerator back pressure.

## 4. Combustion air supply

1. Air passing through the burner for combustion must contain at least 16% oxygen.
2. Eclipse Incini-Cone burners operate at a pressure drop of between 1,25 mbar and 7,5 mbar. Optimum operation is obtained at 5 to 6,5 mbar drop.
3. Profiling of the process stream is required. Refer to the Selection 420 for the necessary diameter of the profile plate orifice.
4. The maximum upstream temperature to the Incini-cone burner is 680°C. Maximum downstream temperature is 900°C.
5. Process stream flow turndown is 2 : 1, based on a 5 mbar maximum pressure drop. Turndown can be extended to 2.45 : 1 with 7,5 mbar pressure drop across the burner. Turndown should not be less than 1,25 mbar pressure drop.

## 5. Installation

1. See Figure 1 for burner mounting. The bolt hole pattern for the mounting flange is given in Figure 2.
2. The customer must supply a gasket between the mounting flange and the chamber shell. Eclipse recommends 1/8" thick fiberglass rope or tape.
3. The burner can be mounted or rotated in any position, and operate in any plane. Positioning of burner spacers must be as shown in Figure 2. However, firing vertically upwards is not recommended.
4. Eclipse determines the diameter of the profile plates (which are customers' supply) based on process data such as: process air-flow, upstream and downstream temperatures and process air turn-down. Calculation could show that profile plate diameter is larger than plug diameter ( $K > A$ ). In this case only three burner spacers will be supplied at the lower part of the burner which must be inserted at an angle through the chamber wall opening. Contact Eclipse for further installation details in case of little space between  $\varnothing K$  and  $\varnothing A$ .
5. Piping and electrical wiring must be done in accordance with all applicable local and/or insurance codes.
6. Read the mounting instructions of the UV scanner carefully to be sure of the correct installation.

**Figure 1: Burner mounting**

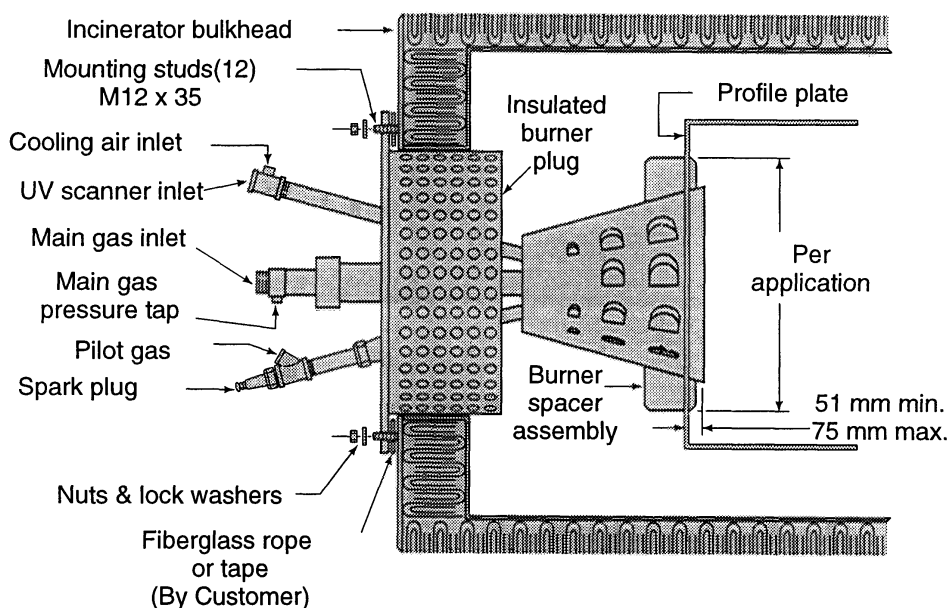

## **6. Piping**

### **6.1 Gas and air piping**

1. Inspect all field piping during assembly for foreign material and pipe scale. Clean piping will ensure trouble free start-up and operation.
2. Do not use teflon tape on threaded pipe connections to the burner assembly. Eclipse recommends the use of Loctite® Teflon Pipe Sealant or equal. Sealant should be applied according to manufacturer's instruction.
3. Use suitable brackets and/or hangers to support piping to the burner. Flexible connections on the main gas are mandatory and must allow the gas nozzle at least 150 mm movement into or out of the burner. Flexible connections are also recommended on the pilot gas line.
4. Install piping disconnects close to the burner for servicing. Inlet pipe sizes at the burner are adequate for short piping runs. If longer piping runs are required, piping losses must be considered and pipe sizes increased accordingly. Sequence times for pilot and main flame ignition must also be considered in pipe sizing.
5. On new installations, gas piping must be purged for air removal.
6. Purge air should be piped to the UV scanner and peepsight inlets. The burner is supplied with piping tees specifically for purge air. See Figure 2 and 3. Provide sufficient purge air to overcome the chamber pressure and keep heat and moisture from working up the sight tubes. Purge air flow is 2 - 3 Nm<sup>3</sup>/h.

### **6.2 Oil piping**

1. Check the correct rotation of the oil pump.
2. On new installations, oil piping must be rinsed for air removal. First the oil piping upstream of the oil filter must be rinsed to remove the heaviest dirt.
3. Often neglected, but very important is that the suction piping of the oil pump is absolutely tight in order to avoid air bubbles, which can cause flame pulsations and flame lifting.
4. After having rinsed the first part of the oil piping, the following part between the oil filter and the flow controller must be rinsed. Disconnect the piping up-stream of the flow controller and open the oil solenoid valve electrically to empty the rinsing oil and to ensure that all dirt is removed from the oil supply.
5. The oil filters must be checked and cleaned if necessary. Oil filters must be checked regularly after burner operation.
6. Purge the air piping for moisture removal.

**Figure 2: Dimensions**

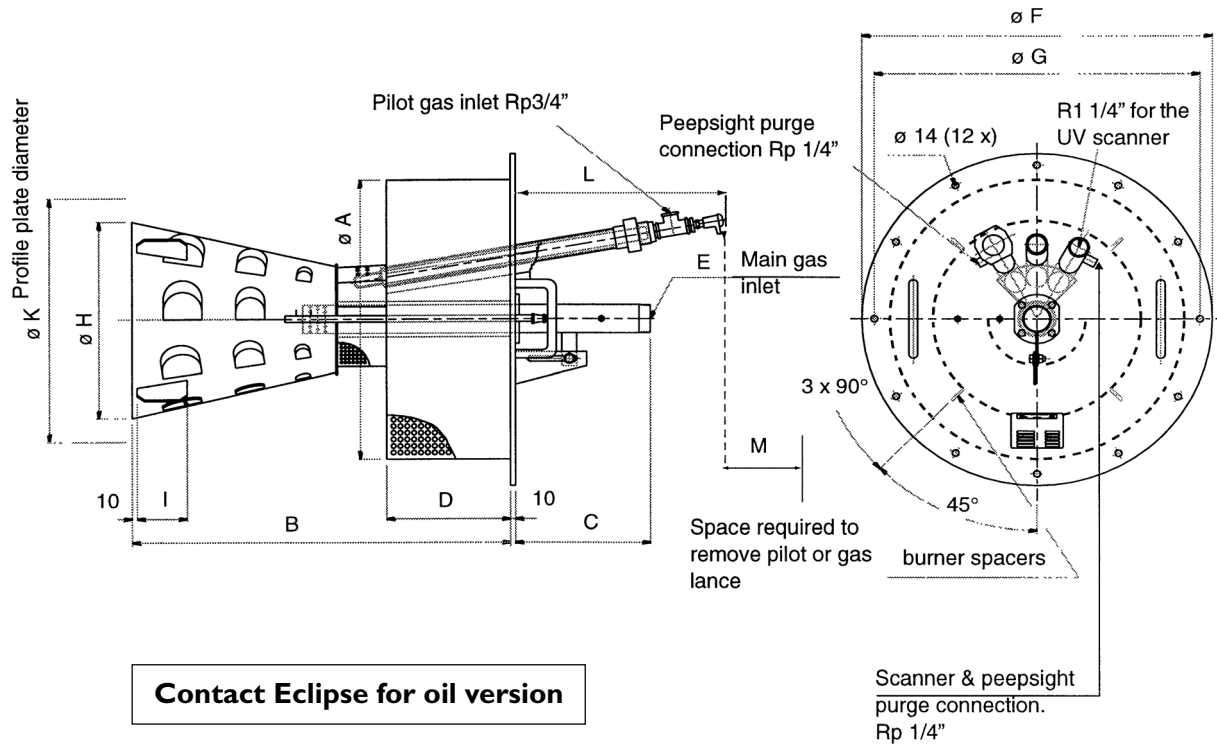

Burner Type	Dimensions (mm)											Approx. Weight kg
	A	B	C	D	E	F	G	H	I	L approx.	M	
136 IC	395	585	275	253	R 1	508	458	260	60	425	1025	40
224 IC	495	635	275	253	R 1 1/4	608	558	300	60	425	1025	55
360 IC	595	715	275	253	R 1 1/2	708	658	390	100	425	1025	60
500 IC	595	765	275	253	R 2	708	658	420	100	425	1025	68
680 IC	595	905	275	253	R 2	708	658	480	100	425	1025	80
900 IC	695	1055	275	303	R 2 1/2	808	758	540	100	375	1025	97
1480 IC	795	1225	340	353	DN80 PN16	930	870	620	100	325	975	140
2960 IC	895	1553	410	353	DN100 PN16	1030	970	844	100	325	1030	250

**Figure 3: Burner installation**

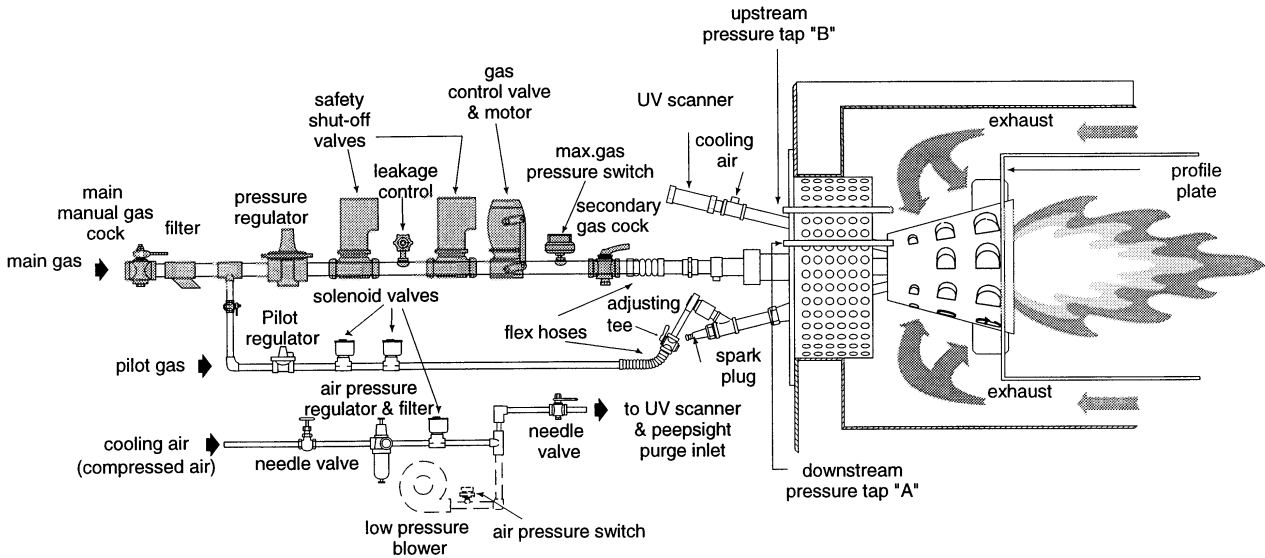

The valve train can be supplied by Eclipse; the connection piping must be customer supplied. All vent piping such as pressure regulator vent, etc. must be customer supplied.

## 7. Pilot adjustment and ignition

1. Check if all electrical components are correctly connected.
2. If possible, test all components on correct operation before burner start-up.
3. Referring to Figure 3, verify that the secondary gas cock is in the closed position. Open the main manual gas cock and the pilot gas cock.
4. The pilot gas pressure is approx. 6 mbar above exhaust gas pressure.
5. Begin ignition sequence on electrical control panel. Check for spark if possible.
6. Begin opening the gas adjusting tee to supply gas to the pilot assembly. Flame can be determined by viewing through peepsight assembly on the burner or by flame signal from the flame relay in the control panel. The pilot flame should be a firm, blue, "torch like" flame. Adjust the flame for a signal sufficient to pull in the flame relay or a steady flame as seen through the peepsight. The flame should not leave the viewing port or flicker on and off.

**Table I:**

Burner	Pilot	Spark plug
136 IC - 680 IC	00.4360004.03	Contact Eclipse
900 IC - 1480 IC	00.4360004.07	Contact Eclipse
2960 IC	00.4360004.09	Contact Eclipse

## 8. Main flame Ignition and adjustment

1. Once the pilot is established, the main gas can be adjusted. Run the gas control valve to low fire.
2. Open the secondary manual gas cock and automatic fuel shut-off valves. Adjust the gas control valve linkage to obtain a stable low fire flame. At this moment the pilot must be interrupted.
3. Drive the gas control butterfly valve to high fire. With a manometer attached to the main gas nozzle inlet tap and to the downstream pressure tap, set linkage to the butterfly valve to obtain a 76 - 89 mbar pressure drop (depending on the selection of the gas nozzle).
4. Drive the control butterfly valve to low fire and check for a stable low fire flame.
5. Cycle the gas control valve to high fire and verify that the pressure drop is consistent with the previous setting. Readjust if necessary.
6. As the incinerator comes up to temperature, backpressures and combustion air temperatures will change. Make final burner adjustments after the incinerator has reached its normal operating temperature.
7. Adjustment on oil: adjust the oil pressure regulator and the oil flow controller to obtain the required oil pressure at high fire.



### Caution

As standard, Eclipse Combustion supplies spare ignition electrodes with an overlength. The necessary length for the specific pilot has to be determined on site. Remove the complete pilot burner. Insert the supplied ignition electrode (remember this is too long). Mark the electrode to allow a 2-3 mm spark gap. Withdraw the electrode and remove the overlength precisely and remove burr. Insert electrode again to the 2-3 mm spark gap position.

**Figure 5: Ignition electrode**

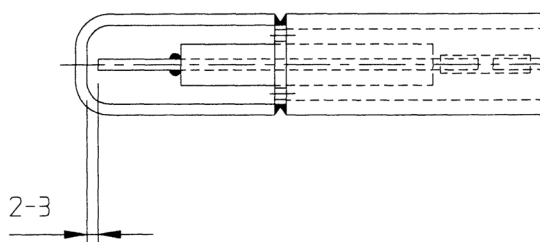

## **9. Maintenance**

A sound preventative maintenance program, carried out by qualified individuals, will greatly increase equipment reliability and productivity. Frequency of maintenance checks should reflect the duty cycle of the heating equipment and conditions such as dirt and temperature.

### **9.1 Maintenance of the ECLIPSE IC burner.**

The burner is very robust, but nevertheless regular maintenance should be carried out.

Prior to burner removal all gas, oil, and electrical connections have to be removed. The burner lances can easily be removed for maintenance. After reassembly the basic burner adjustment must not be changed and the flange connection must remain perfectly tight. Residual deposits have to be removed, especially in case of an oil lance.

#### Oil lance

The maintenance of the oil lance should take place twice a month. The oil lance should be cleaned of the oil residues and the gaskets should be checked. The nozzle must be cleaned with a solvent. The main dirt in the nozzle orifices can be removed by a copper wire. **CAUTION!!** It is not allowed to file or to scrape.

The gaskets of the nozzle must be perfectly tight; no oil leakage is allowed.

As soon as the oil cone is not symmetrical the oil lance must be replaced by another atomizer. The oil lances should be stocked vertically in the protection tubes.

#### Gas lance

The maintenance of the gas lance should take place twice a year. The outlet openings of the nozzle must be free from dirt. Check the gaskets for tightness. If necessary, replace gaskets as per Eclipse recommendations.

### **9.2 Maintenance of the ignition electrode.**

Check the ignition electrode every month. Clean the electrode if necessary.

### **9.3 Maintenance of the flame supervision.**

The UV scanner has to be inspected at least once a week.

The UV scanner glass can be cleaned with alcohol and a soft, clean rag if necessary.

The power supply must be cut off when cleaning the UV scanner glass.

Avoid fingerprints on the UV scanner tube.

Check for leakages after reassembly.

To guarantee a safe operation, the UV scanner should be replaced after 10.000 operating hours at least.

### **9.4 Maintenance instructions of other equipment.**

See the manufacturers operating manuals.



## 9.5 Adjustment instructions for the gas nozzle of the Incinicone burner

**Figure 4: Gas nozzle adjustment**

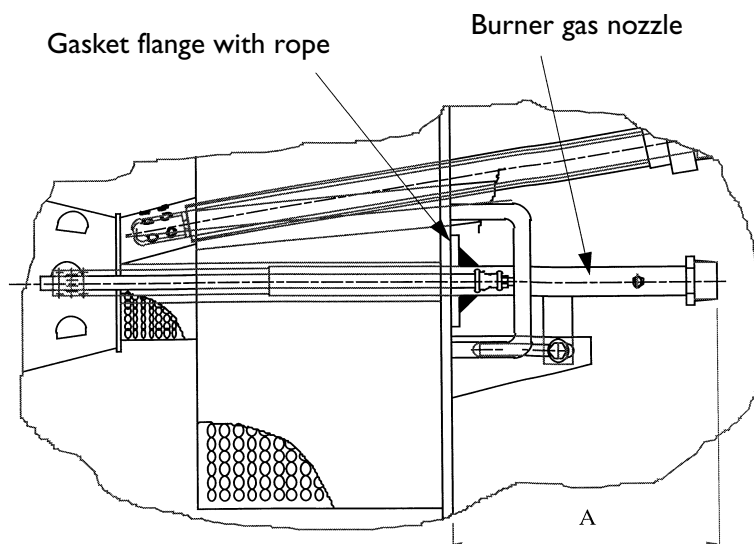

Dimension "A" is preset at factory

Burner type	Dimension "A"(mm)	Adjustable from (mm)
136 IC - 680 IC	275	195 - 285
900 IC - 1480 IC	340	260 - 350
2960 IC	410	330 - 420

In case of problem with flame stability (flame lifting , poor flame signal from UV scanner):

1. Slightly loosen the gasket flange
2. Push the gas nozzle slowly forward (decrease dimension "A")
3. Tighten the gasket flange after having finished the adjustment.

Once the gas nozzle is adjusted in the correct position, if necessary, the gasket flange can be welded to the gas nozzle to ensure tightness.

## 10. Trouble shooting

Failures can occur in different equipment and following checks should be carried out:

### 10.1 Failures in the flue gas system.

- Process air blower operation?
- Correct direction of rotation?
- Position of dampers?
- Proper function of process air pressure switches?
- Check the profile plate diameter.

### 10.2 Failures in the gas supply.

- Is gas pressure available?
- Is the gas cock open?
- Is the gas filter clogged?
- Performance of the pressure switches?
- Reset of the main gas pressure regulator?
- Performance of the gas pressure regulator?
- Performance of the solenoid valves?
- On oil: is the oil pump operating?
- On oil: are the oil filters clogged?
- Are the gas/oil pipes purged?

### 10.3 Ignition problems.

- Does the spark or pilot flame appear?
- Condition of the ignition cable?
- Correct position of ignition electrode (at pilot end)?
- Is the spark produced in the spark plug cap?
- Correct performance of the ignition transformer?
- Does the sequence programmer emit the correct impulse for the ignition?
- Condition of the connecting wiring?
- Is the electrode gap correct?
- Are the insulators of the ignition electrode broken so that spark can be produced against earth?
- Correct gas pressure available?

### 10.4 Failure: “maximum gas pressure”.

- Gas pressure at burner inlet too high?
- Proper function/adjustment of max. gas pressure switch?

### 10.5 Failure: “maximum temperature”.

- Proper function of temperature control system?
- Proper function/adjustment of maximum temperature switch?

### 10.6 Burner pulsates.

- Check if the flue gas pressure varies.
- Check if the gas/oil pressure varies.
- Is the flue gas pressure too high?
- Is the gas pressure too high?
- Is the compressed air pressure too high?
- Correct performance of the UV scanner?
- Correct performance of the temperature control system?
- Check electrical equipment for firm contacts.
- Check the ignition electrode every month.
- Clean the electrode if necessary.

### 10.7 Unsatisfying combustion results.

- Are the control valves correctly tuned?
- Negative influence on oil flow due to clogged pressure regulator or clogged nozzle?
- Are the combustion chamber conditions perfect?
- Are the basic pressure conditions changed?
- Are the pressure conditions on burner and profile plates perfect?
- Dirt in gas/oil pipe lines?

### 10.8 Burner failure.

- Correct performance of the UV scanner?
- Is the viewing path to the UV scanner clear over the whole cross section and for all flame sizes?
- Is the UV scanner tube completely free from any obstruction?
- Is the sequence programmer operating correctly? (simplest way to check is to plug in a new programmer).
- Check all electrical operations.
- Check the gas solenoid valves.
- Check the performance of the pressure switches
- Is the purge air for UV scanner available?

### 10.9 Failure: “Start position control valve”

- Correct position of gas control valve?
- Is the start switch in closed position?

### 10.10 Failure: “Closed position safety valves”

- Safety valves in closed position?
- Closed position switch closed?