

**Experion LX Foundation Fieldbus
Integration Specification**



LX03-470-120

Release 120

February 2015, Version 1

Revision History

Revision	Date	Description
1	January 2015	Release version

Table of Contents

1. Product Introduction	4
1.1. Foundation Fieldbus	4
1.2. Experion LX Integration	4
1.3. Terminology	4
2. Product Overview	5
2.1. Series 8 FIM4 Kit	5
2.2. Easy Engineering with Control Builder (CB).....	6
2.3. FIM Redundancy.....	7
3. FDM (Field Device Manager)	7
4. Fieldbus Host and Device Testing and Validation	7
4.1. Fieldbus Host Interoperability Test.....	7
4.2. New Host Profile Registration Process	7
5. Fieldbus Device Interoperability Testing	8
6. H1 Power Conditioner Basics	9
7. Performance Limits	10
7.1. Specifications	10
7.1.1. System	10
7.1.2. FIM.....	11
7.1.3. H1 Network.....	13
7.1.4. Active Link Schedule	14
7.1.5. Alarming	14
8. Model Numbers and Specifications	15
8.1. Model Numbers.....	15
8.2. Specifications.....	15
8.2.1. PCM.....	16
8.3. Fieldbus Usage Model Numbers.....	17

1.

Product Introduction

1.1. Foundation Fieldbus



FOUNDATION fieldbus™ (FF) is an enabling technology for integrating field devices with digitally-based (Host) process control systems. It defines how "smart" field devices communicate and operate with other devices in a control network. The Fieldbus Foundation is the leading organization dedicated to a single international, interoperable fieldbus standard and responsible for FOUNDATION fieldbus. For more information about the Fieldbus Foundation, see the following website.

<http://www.fieldbus.org/>

1.2. Experion LX Integration

The **Experion LX®** System provides an effective and robust fieldbus interface through the Field Interface Module (FIM4).

The generic name used to identify the kit is FIM4 Kit. The Experion LX FIM4 Kit is a high-performance component that completely and transparently integrate FOUNDATION Fieldbus devices into the Experion LX.

A numerical suffix is added to the FIM designation to indicate the number of FF H1 networks that are provided by the module.

- **FIM4 Kit** with 4 H1 networks

FIM4 Kit can be used standalone or with the C300 process controller.

1.3. Terminology

Fieldbus terminology used in this document:

- **H1:** A term used to describe a Fieldbus network operating at 31.25 kbits/second.
- **H1 Field Device:** Compliant Field Devices (valves, transmitters, analyzers, etc.) that connect directly to an H1 fieldbus.
- **Interoperability:** The ability for multiple disparate devices from multiple vendors to operate safely and interact properly (per foundation specifications) on the same Fieldbus H1 network.
- **Link:** A Link is the logical medium by which H1 Fieldbus devices are interconnected. It is composed of one or more physical segments interconnected by bus Repeaters or Couplers.
- **LAS:** All of the devices on a link share a common schedule, which is administered by that link's current LAS (Link Active Scheduler). It is the data link layer name for a network.
- **Network:** A network as applied in this document is the termination of one or more Fieldbus segments into an interface card of the host system. In this document the term "link" and "network" are used interchangeably.
- **Segment:** A Segment is a section of an H1 fieldbus that is terminated in its characteristic impedance. Segments can be linked by Repeaters to form a longer H1 fieldbus. Each Segment can include up to 32 H1 devices.

2. Product Overview

2.1. Series 8 FIM4 Kit

All Series 8 interface modules, I/O modules, and the C300, use the concept of an IOTA (Input Output Terminal Assembly) where the IOTA mounts to a standard Series 8 mounting channel assembly. This provides for a standardized cabinet, mounting, power, and grounding infrastructure for all Series 8 modules (for additional details, see the appropriate Experion LX documentation).

As Figure 1 shows FIM4 module is mounted to a FIM4 IOTA. The FIM4 IOTA is 12 inches long and install on a din rail case. Redundant kit provide two FIM4 modules on IOTA, non-redudant kit use one FIM4 module on it.

Figure 1 also shows the various connection points. Note that 24 Vdc (to power the modules) is provided from the Power Control module (PartNumber: 51307038-100). There are also FTE (green & yellow) connectors for each FIM4 module. The FIM4 FTE (IP) index address is set using the rotary switches on the IOTA. This represents the last octet of the four octets that make up the complete FTE IP address. However, you can implement conditioners from other 3rd party vendors and hard wire the conditioners using standard FF H1 practices. Note that all power conditioners and the H1 network are isolated from the Series 8 power system.

The FIM4 is a standard FTE node. FIM4 can be used with a process controller or can be standalone. When used with a process controller it can only be a C300.

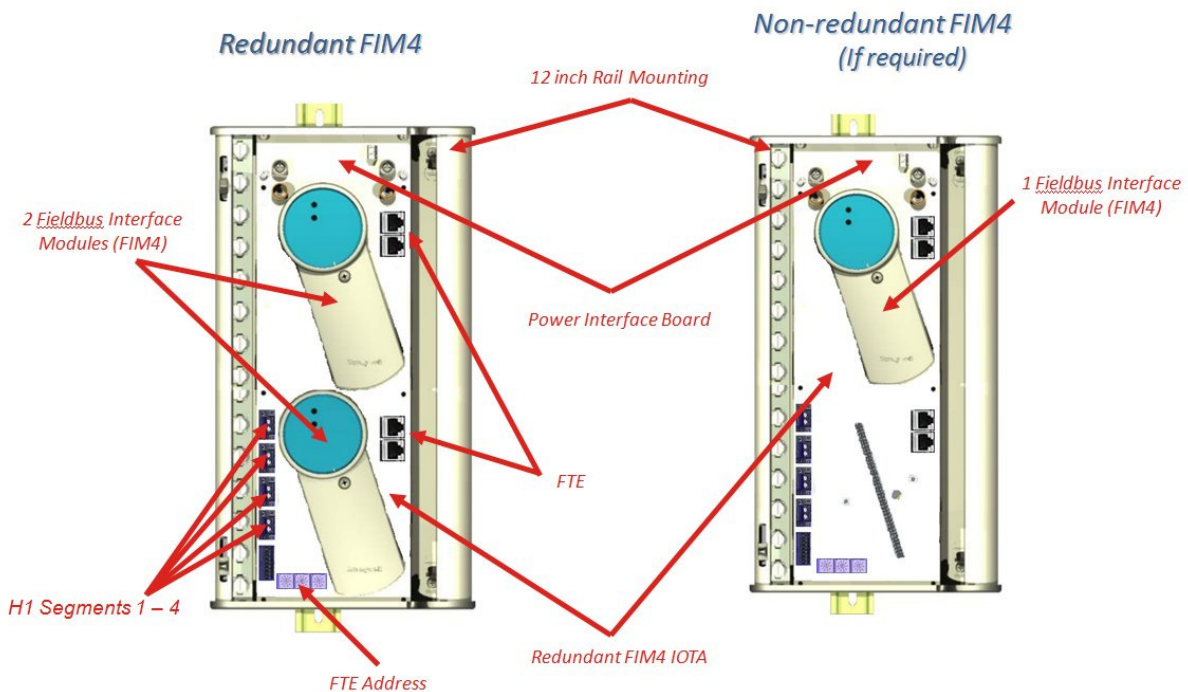

Figure 1: Series 8 FIM4 Kit types and configurations (redundant and non-redundant)

2.2. Easy Engineering with Control Builder (CB)

Control Builder is the Experion LX graphical engineering tool for creating and configuring process control strategies, including those utilizing fieldbus. Time-saving fieldbus-specific features such as:

- Creation of FF device templates from vendor DDs and EDDLs (starting in Experion LX R120)
- Full device configuration from within CB
- Assignment of FF device function blocks to the control strategy
- Commission and un-commission devices
- Device firmware download
- Device replacement wizards
- Initiate and run device methods
- Device maintenance and troubleshooting
- Parameter comparison and reconciliation
- FF Field diagnostics

Chart Visualization to get the correct information to the operator

Chart Visualization is a powerful feature that presents device blocks (Resource and Transducer) and function blocks (AI, AO, PID, and so on) with all manufacturer-defined information directly to the operator. With Chart Visualization, there is no need for custom forms or displays for every type of device.

There is also no need to worry about the security of parameters. Access follows the Station security level and is the same as parameters for all other displays. No special engineering effort is required, and implementation time is minimal. Experion LX provides flexibility to create your own custom detail displays. Experion LX also features device replacement directly from the operator station. A failed or troublesome device can be securely replaced with a new or repaired one without need for engineering support.

Experion LX R120 and higher supports vendor provided EDDL files that greatly enhance the device HMI by the use of graphics and trends, and by allowing the device vendor to better define where and how parameters are displayed and located.

Full Support for Link Active Schedule and Backup Link Schedule

The Link Active Scheduler (LAS) can be considered the traffic cop that determines when and how every FF device (including the FIM) will access the H1 network and what data they will transfer. One device (at any given time) is the LAS. Others can be assigned as backups in the event the lead LAS fails (backup FIMs are always considered the first backup LAS device). Other FF devices can also be configured as backup LAS devices.

LAS setup and management is essential for effective FF H1 communications. Experion LX provides a best in class solution for the management of the LAS component. Graphical support of the Link Active Schedule (LAS) is an important Experion LX tool for building schemes around fieldbus. Experion LX supports the Back-up Link Active Schedule in multiple LAS-capable devices, for the highest possible robustness. Link Schedule Optimization maximizes available communications bandwidth, allowing for more devices and better performance, resulting in significant cost savings over competitive systems.

2.3. FIM Redundancy

FIM4 type support full automatic redundancy. Fieldbus function blocks continue to execute and communicate during switchover or failover. With Honeywell's advanced diagnostics, the primary and secondary FIM modules are in constant communication. The absence of a redundant partner, for example, is detected and announced to the user in the form of a system notification, not a process alarm. Diagnostics are also provided for a potential failure or problem with fieldbus power. In the event of a power problem on the RTP, IOTA, or link, the FIM alerts the operator with a system alarm.

3. FDM (Field Device Manager)

Experion LX Control Builder and Station provides all the tools and capabilities required to configure, monitor, and manage fieldbus devices and associated control strategies. Users can also identify and respond to device faults.

FDM augments this capability and includes additional functions and features focused on FOUNDATION fieldbus devices and coverage in the asset management arena. FDM communicates through the FIM to access fieldbus devices. FDM is intended for maintenance users and provides an environment optimized for their needs. FDM and Experion LX provide a complete fieldbus solution.

For more information about FDM, see the latest FDM Specification.

4. Fieldbus Host and Device Testing and Validation

4.1. Fieldbus Host Interoperability Test

For all releases prior to Experion LX R120, the Experion LX fieldbus solution has successfully completed the **Foundation Fieldbus Host Interoperability Support Testing** (HIST), performed at Honeywell's Fieldbus Interoperability Test Lab and witnessed by a Fieldbus Foundation representative. HIST procedures provide a common methodology for assessing host interoperability with registered devices.

As of January 2009, the Fieldbus Foundation has implemented a new and mandatory validation process for Host systems referred to as the "Host Profile Registration" process.

4.2. New Host Profile Registration Process

The Fieldbus Foundation's previous Host Interoperability Support Test (HIST) provided a host test protocol with no provision for formal product registration. With HIST, the host vendor chooses the implementation.

As of January 2009, all Host systems must pass a formal test process (administered by the Fieldbus Foundation) to be considered an official registered Host.

Under the new Host Profile Registration Process, the Fieldbus Foundation conducts functional testing with a test device and specialized testing of Device Descriptions (DDs) and Capabilities Files (CFs). The host profile under test must support a clear set of required features.

Use of the Foundation Product Registration symbol in conjunction with a Fieldbus Foundation -registered Host is the manufacturer's representation that a sample of the product has successfully completed all requirements specified in the Host Profile Registration Process.

From Experion LX R120 onwards, Experion LX is a 61a compliant system and has passed all required Host Profile registration testing.

Refer to the foundation website at the following link for proof of compliance. Host systems that have not passed the formal testing cannot appear on the website, <http://www.fieldbus.org/>.

5. Fieldbus Device Interoperability Testing

Experion LX uses vendor compliant device DD and EDDL files in Control Builder to create a library of fieldbus devices and their function blocks. Experion LX also uses Control Builder's off-line capabilities to implement strategies involving fieldbus devices and to support live device commissioning.

For the system and the FIM to work properly, devices must be registered with the Fieldbus Foundation and must comply with a supported ITK (Interoperability Test Kit) level. The test kit verifies the functionality of an H1 (31.25 kbit/s) device and its conformity with the FOUNDATION fieldbus Function Block and Transducer Block specifications.

Experion LX supports ITK levels 4.0 and higher.

To further ensure proper operation, Honeywell maintains a Fieldbus Interoperability Test Laboratory for testing FOUNDATION fieldbus devices with Experion LX. This testing is provided to the customer and the device vendor at no charge.

Although most devices integrate without problems, in some cases issues may arise due to differences with regard to the interpretation of FOUNDATION fieldbus specifications. If problems arise, Honeywell and the device manufacturer work together to successfully integrate the devices. This sometimes requires the use of a Honeywell modified DD or EDDL file for proper operation with a particular version of Experion LX.

To download DD files for devices that have been tested, or for contact information to schedule device testing, see our website, <http://www.honeywellprocess.com>.

6. H1 Power Conditioner Basics

The diagram in Figure 2 provides a simple depiction of a typical H1 network. All FF devices are connected to the network in parallel. The power conditioners (non-redundant or redundant) are also connected to the network in a parallel arrangement and supply the 24 Vdc to power required by each connected Fieldbus device.

A typical device will use between 10 and 20 mA. The number of devices and the power consumed by each device determines the size of the required power conditioner (in amps) required. For the example below, assume each device requires 20 mA to operate properly. The power conditioner would need to be capable of supplying 80 mA (4 x 20 mA).

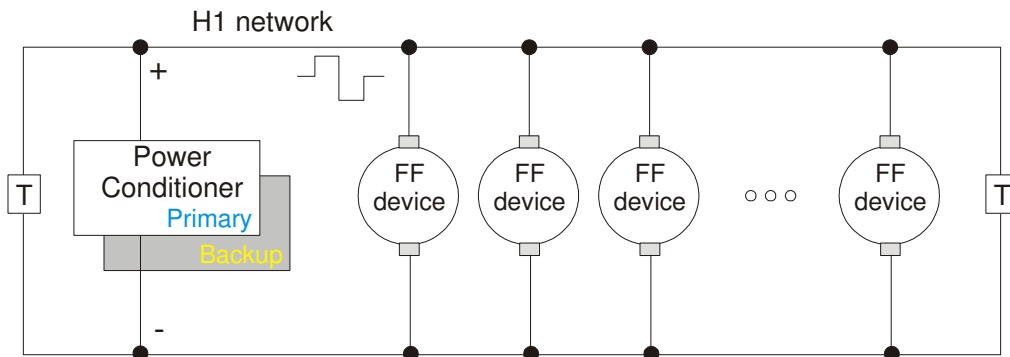

Figure 2: H1 Power Conditioner Basic Diagram

A terminator must be placed at each end of the network (or each segment) to support proper communications.

Digital communications

Each device (when communicating on the H1 link) will toggle the 24 Vdc to generate the digital portion of the H1 communications. An H1 power conditioner must have added circuitry to tolerate this digital component and still provide the 24 Vdc required by each device. A standard off the shelf power supply could not provide this capability (this is what makes the power conditioner unique). The FIM4 is considered a device with regard to this example. Although they do not use any power from the conditioner for their operation, they will use about 10 mA when signaling on the H1 link.

Power Conditioner Validation

Honeywell **does not** validate any 3rd party power conditioners at this time. Any power conditioner that complies with the Fieldbus Foundation test specification FF-831 (Fieldbus Power Supply Test Specification) should operate properly with the Honeywell FIM modules. Power conditioners may provide other features that make them suitable for applications such as intrinsic safety. For more information about these products and features, see the 3rd party websites..

7. Performance Limits

7.1. Specifications

7.1.1. System

FF System Specifications	
Capacity Description	FIM4
Maximum Number of FIMs per Controller ²	15 Redundant or non-redundant in any combination (60 H1 Links)
Maximum Number of FIMs per Server	15 Redundant or non-redundant in any combination
Maximum Number of Fieldbus Devices per Server	960
Note – Any redundant and non-redundant combination cannot exceed 21 “Active/Primary” FIMs	

7.1.2. FIM

FF FIM Specifications	
Capacity Description	FIM4
Number of H1 Networks per FIM	4
Maximum Number of FF Blocks per Fieldbus Device	30
<p>Maximum Number of FF Blocks per FIM</p> <p> ATTENTION</p> <p>Blocks are counted whether or not the FF Device's Blocks are being used/loaded or not in the FIM strategy. Resources to support every Device's Block set must be reserved when the FF Device is configured on one of the FIM's H1 Networks.</p> <p>For example, a device with 1 resource block, 5 transducer blocks and 5 function blocks will consume 11 blocks from the total block count. It does not matter if the function blocks are in use or not.</p>	1600
<p>Maximum Number of Unique FF Block Types per FIM</p> <p>Note: Unique FF Block Types are defined as the number of unique blocks across all devices connected to a FIM. Each time a new unique device is connected to the link, one unique block type may be reserved for each unique block in that device.</p> <p>For example, suppose device X, containing an AI and a PID block, is connected to a FIM. This would reserve two unique block types. Adding several more of this device to the FIM would not require additional unique block types. Suppose a different device Y, containing an AO, is connected to the FIM. This would reserve one unique block type.</p>	200
<p>Maximum Number of Parameters in FIM cache</p> <p>Note: The maximum number of parameters in the FIM cache defines the maximum number of parameters that may be accessed for control, monitoring, and configuration at any given time.</p>	1600
Maximum Peer Connections per FIM	5
<p>FIM Publication Method options¹</p> <p>Note: The FIM Publication Method (PUBMETHOD) is configurable on a per segment/H1 network basis on the FF Link function block and controls how frequently data is published between the FIM4 and C300 controller.</p>	Immediate 250 msec 500 msec 1000 msec
Overall Data Access performance - CDA	1600 PPS
<p>FIM Cache Parameter Refresh Rate</p> <p>Note: FIM Cache will refresh parameter values at a maximum rate of once per second. If all parameters cannot be refreshed within one second due to bandwidth limitations, the FIM will allocate additional time as needed. Actual performance will depend on number of parameters within FIM Cache, device performance, and unscheduled bandwidth available on H1 Network</p>	1 second minimum

FF FIM Specifications	
Capacity Description	FIM4
<p>Note 1 – This option provides a trade-off between controller performance and control end-end response time. Slower publication will reduce the network traffic and the performance load on the controller, but increase the overall end-end response time of a loop (assume AI and AO devices are on H1 and PID is in C300). Conversely, faster publication will increase the network traffic and increase the performance load on the controller, but decrease the overall end-end response time of a loop.</p>	

7.1.3. H1 Network

FF H1 Network Specifications	
Capacity Description	FIM4
<p>Maximum Number of Fieldbus Devices per H1 Network</p> <p>Note: The maximum number of supportable devices per network is highly dependent on application, bandwidth, devices, available current, bus length and topology. An understanding of Fieldbus is crucial to system sizing.</p>	16
<p>Agents per H1 Network</p> <p>Note: An agent is used to transport data between CEE blocks and FF blocks. Agent specifications are measured on a per H1 Network basis. Agents are displayed in the link schedule when viewed with Control Builder.</p> <p>A connection between a CEE block and an FF block reserves one agent.</p>	100 per H1 Network
<p>Maximum Number of VCRs (Virtual Communication Relationships) per H1 Network</p> <p>Note: A VCR is a connection endpoint on the H1 Network. VCR specifications are measured on a per H1 Network basis.</p> <p>Each connected device reserves two VCRs. A published connection between a CEE block and an FF block reserves one VCR. A published connection with back initialization between a CEE block and an FF block reserves two VCRs. Connections between FF blocks on a single device or between multiple devices do not reserve VCR resources on the FIM. It is recommended that at least one VCR be left free to facilitate device replacement and any control strategy reloading.</p>	128 per H1 Network, 512 per FIM4 ¹
<p>Maximum Scheduled Single-Variable Publications per Second per H1 Network</p> <p>Note: Scheduled Single-Variable Publications per Second may include publications from devices to other devices, from devices to the FIM, and from the FIM to other devices.</p>	16 per H1 Network
<p>Unscheduled Parameter Reads per Second per H1 Network</p> <p>Note: Unscheduled parameter read performance is provided as a guideline. Actual performance will depend on device performance and unscheduled bandwidth available on H1 Network.</p>	16 per Fieldbus Device, 40 per H1 Network
<p>Unscheduled Parameter Writes per Second per H1 Network</p> <p>Note: Unscheduled parameter write performance is provided as a guideline. Actual performance will depend on device and unscheduled bandwidth available on H1 Network.</p>	5 burst, 1 sustained per Fieldbus Device, 20 burst, 5 sustained per H1 Network
<p>Available Macrocycle Periods</p>	250, 500 msec; 1, 2, 4, 8, 16, & 32 sec.
<p>Note 1 – Device reload or device replacement functionality requires at least one free VCR on a Fieldbus link/segment. If a segment is configured with the maximum number of VCRs allowed (128 for the FIM4), a device replacement will not be able to done without freeing a VCR on the segment first. Freeing a VCR is typically done by deleting a CM or device from the monitoring tree. Therefore, it is recommended that at least one VCR is kept free so that device reloads or replacement will not require a VCR to be freed first. Control Builder will display a warning message when a segment is low on free VCRs.</p>	

7.1.4. Active Link Schedule

FF Link Active Schedule (LAS) Specifications	
Capacity Description	FIM4
Number of LAS Domains per FIM	2
Maximum LAS Schedule Size	2000 bytes/LAS
Number of Sub-schedules per LAS Note: For example, a 2 second macrocycle could have sub-schedule periods of 1 second, 500 msec, and 250 msec.	4
Number of sequences per sub-schedule	64

7.1.5. Alarming

FF Advanced Alarming Specifications	
Capacity Description	FIM4
Custom conditions per device template	32
Device parameters used in any/all conditions, per device template	10
Individual parameter references, per device template ¹	36

8. Model Numbers and Specifications

8.1. Model Numbers

Model Number	Model Description
S8-KFB4A1	Series 8 FIM4 Kit, Redundant
S8-KFB4B1	Series 8 FIM4 Kit, Non-Redundant
51307038-100	Power Control Module Assembly

8.2. Specifications

Series 8 Foundation Fieldbus Interface Module with 4 H1 Links (FIM4) Kits

Parameter	Specification
Physical Interface	H1 Foundation fieldbus
Number of H1 Networks per FIM (Each network defined as a Foundation fieldbus 31.25 kbps H1 network)	4
Indicators on Module	<ul style="list-style-type: none"> 24V Power, Module & FTE Status LEDs Front display panel with module and link state information
Indicators on IOTA	4 H1 Link Status LEDs (1 per Link)
Configurations	Non-redundant or redundant (side-by-side)
Electro-static Discharge	IEC 1000-4-2: 1995
Power Dissipation	5.3 watts
Module Current	0.212 amps @ 25 Vdc
H1 Link Connection	Using connectors on the IOTA

8.2.1. PCM

Parameter	Specification
Number of Inputs	2
Input Voltage Range	16~32 VDC
Number of Outputs	8
Load Current	Total 20 A Max @ 24 VDC
Under-Voltage Shutdown	DC output to the whole system is shutdown when the output power is lower than 19V.
Over-Voltage Shutdown	DC output to the whole system should be shutdown when the output power is higher than 28V.
Alarm	When the DC input voltage is not in normal status, output alarm signal.

8.3. Fieldbus Usage Model Numbers

CV-FFLXxx, are required based on the total number of FIMs (redundant or non-redundant pair) per Server actually in use. This applies equally to Series 8 FIM4. License model numbers are purchased in combinations that support the total number of FIMs required. Licenses must be purchased starting with the first FIM used.

Fieldbus Usage License Models (applicable to all FIM types)

Fieldbus Usage Licenses	
CV-FFLX01	Fieldbus Usage License, 1 FIM (FIM4)
CV-FFLX05	Fieldbus Usage License, 5 FIMs

Experion LX™ is a trademark of Honeywell International Inc.

All other products and brand names shown are trademarks of their respective owners.

This document contains Honeywell proprietary information. It is published for the sole usage of Honeywell Process Solutions' customers and prospective customers worldwide. Information contained herein is to be used solely for the purpose submitted, and no part of this document or its contents shall be reproduced, published, or disclosed to a third party without the express permission of Honeywell International Inc.

While this information is presented in good faith and believed to be accurate, Honeywell disclaims the implied warranties of merchantability and fitness for a particular purpose and makes no express warranties except as may be stated in its written agreement with and for its customer.

In no event is Honeywell liable to anyone for any indirect, special or consequential damages. The information and specifications in this document are subject to change without notice.

For more information

To learn more about Honeywell's products or solutions visit our website www.honeywellprocess.com or contact your Honeywell account manager.

Automation & Control Solutions

Process Solutions
Honeywell

1250 West Sam Houston Parkway South
Houston, TX 77042

Honeywell House, Arlington Business Park,
Bracknell, Berkshire, England RG12 1EB UK

Shanghai City Centre, 100 Junyi Road
Shanghai, China 20051
www.honeywellprocess.com

LX03-470-120
February 2015
© 2015 Honeywell International Inc.

The Honeywell logo is displayed in a bold, red, sans-serif font.