

PlantCruise by Experion[®]: Your Right Partner for Pharmaceutical Operations

Solution Note

Honeywell's PlantCruise by Experion Distributed Control System (DCS) is a perfect fit for pharmaceutical and biotech operations of any size or scope. With this solution, multi-purpose facilities can achieve DCS level control at lower lifecycle costs for more reliable, agile, safer and efficient batch operations.

To stay competitive, today's pharmaceutical firms must safely and consistently manufacture high-quality products on time and within licensed processes, while maintaining GMP-compliant conditions and minimizing batch-to-batch variability. The requirements of the US Food and Drug Administration (FDA), European Medicines Agency (EMA), China Food and Drug Administration (CFDA), and other regulatory bodies are among the toughest in the world. Regulatory compliance failures often result in penalties and reputational damage.

Drug companies require agility across all aspects of their operations. Laboratory findings must be transferred as quickly as possible to the production environment, and production plants need the flexibility to keep pace with dynamic market conditions.

Although Distributed Control System (DCS) technology offers advantages for modern biopharmaceutical operations, the right solution should be flexible, scalable and purpose-built with the latest technology.



High quality products, shorter time to market, compliance to regulations and agility to adopt production changes continues to drive the life-sciences industry.

FEATURES & BENEFITS

- Increased batch execution availability and throughput by executing a complete procedure in a redundant ISA S88 model based deterministic controller
- Higher system availability through redundant Experion controllers, IOs and Direct Station
- Improved operator usability through display integration and interactive instructions
- Execute batches using multiple batch units from the procedure level downwards in the ISA88 hierarchy
- Easy to use, single configuration tool for creating continuous, sequential, batch and model based control
- PlantCruise executes procedures directly in the controller and can increase throughput by up to 3%
- QVCS capabilities designed for well-enforced lifecycle and implementation procedures and reduced number of SOPs as per US FDA 21 CFR Part11
- Sequence execution cycle time is configurable as fast as 50 milliseconds.
- Class based master recipes that helps maintain agility while adapting to production changes
- Highly modular and scalable system that meets your expansion needs
- Improved operator usability through display integration and interactive instructions
- HMI designed as per ASM guidelines for safer and efficient operations
- Latest OS (Windows 10 and WS2016) for longer platform support promise

Honeywell offers the PlantCruise DCS as a “perfect fit” for differently sized facilities. With this scalable control system, various functions and applications aimed at optimizing performance are inherently available in the context of pharmaceutical operations. Data from these functions is also presented in an integrated operating environment. Comprehensive and integrated DCS and SCADA functionalities makes PlantCruise a suitable product for both API and FPP type pharmaceutical segments.

Solution

From production management and batch control, to the diverse formulation process, biopharmaceutical facilities are highly complex and multi-dimensional with numerous critical operations. They need plant-wide integration and lifecycle optimization, including real-time and interactive access to data used for planning, managing and optimizing production.

Typical applications within pharmaceutical plants include:

- Batch automation
- Procedural operations
- Qualification and version control

- Electronic records/signatures
- Recipe management
- Pilot plants
- Synthesizing/fermentation
- Clean Room Monitoring

The rewards from investing in automation can be substantial, such as considerable increases in productivity and improved safety, with reduced costs. However, there are common industry-wide issues associated with implementing new technology, which can have varying impacts on the success of pharmaceutical producers. For many pharmaceutical plants, making the right investment in automation can be difficult. There may be sites that cannot justify the cost and complexity of a full DCS. There are also plants that have adopted Programmable Logic Controllers (PLCs) but are a better fit for a DCS.

Honeywell is a leading supplier of control solutions for the Pharmaceutical and Life Sciences industries, with a worldwide presence and broad application experience. We offer the PlantCruise DCS as a “perfect fit” for differently sized facilities. With this scalable control system, various functions and applications aimed at optimizing performance are inherently available in the context of pharma operations. Data from these functions is also presented in an integrated operating environment.

PlantCruise is based on Honeywell’s award-winning Experion Process Knowledge System (PKS), which is recognized for its advanced technology, robust software packages and monitoring, built-in redundancy, ability to integrate with Manufacturing Execution System (MES) platforms, and full validation support.

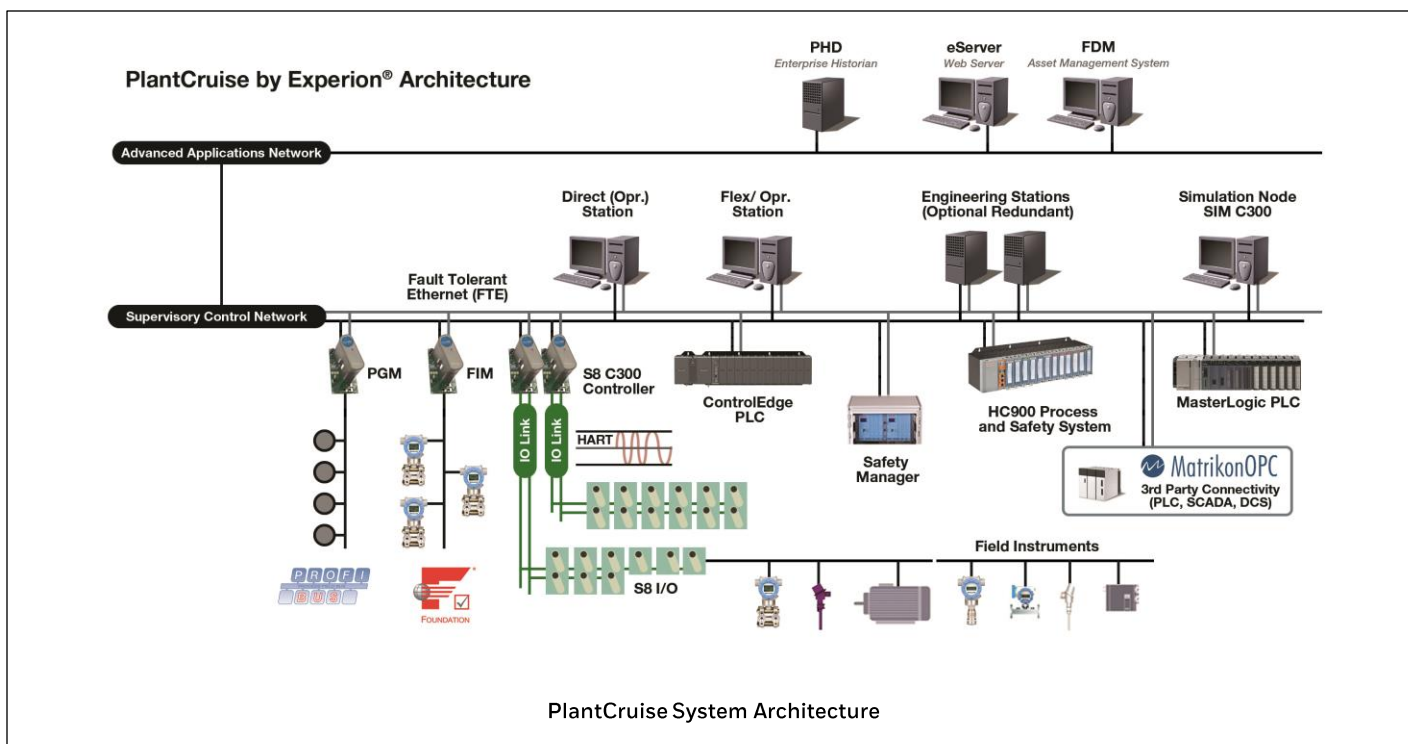

PlantCruise leverages Honeywell's proven track record in DCS applications, and is a mature system with well-defined function blocks and highly proven technology. It is a unique automation solution superior to traditional PLCs for many operations.

PlantCruise's innovative technologies are vital to improved plant performance and better business results, and can be implemented in a way that suits your individual site.

- Tightly integrated DCS and Supervisory Control and Data Acquisition (SCADA)
- Honeywell's Experion C300 controller for robust and versatile control
- C300 simulation for proving out control strategies
- Honeywell's patented, high-performance Fault Tolerant Ethernet (FTE) control network
- Optional redundancy at all levels: server, network, C300 controller and Series 8 I/O modules
- Direct Station never loses view or control of field devices
- Honeywell's patented, revolutionary Profit[®] Loop algorithm for predictive control
- Unique I/O module design for compact footprint, and efficient installation and maintenance
- Improve efficiency and reduce configuration time by up to 30% with Honeywell's enhanced Control Builder and newly styled Human-Machine Interface (HMI)
- IEEE 1588 Precision Time Protocol (PTP) support for system-wide SOE
- Powerful reporting tool for debugging and system maintenance
- Smart device integration through industry-standard protocols such as HART[®], FOUNDATION[™] fieldbus, PROFIBUS and Modbus[®]
- Asset management using Honeywell's integrated Field Device Manager (FDM) software
- Enhanced features with Pan and Zoom Displays, Equipment Templates, Dynamic Scanning, etc.
- Extensive integration of PLCs, DCSs, Remote Terminal Units (RTUs), drives, safety systems and weigh scales through rich SCADA capability and Matrikon OPC servers
- Honeywell's flexible Distributed Server Architecture (DSA) for integration of processes across multiple units, control rooms or geographically separated locations for optimum flexibility and system maintenance
- Virtualization solutions intended to improve performance and reliability in the industrial automation domain

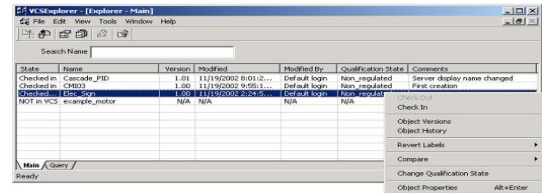

QVCS with Detailed Check-in and Check-out Features

PlantCruise's Qualification and Version Control System (QVCS) capabilities establish well-enforced lifecycle and implementation procedures and reduce the number of Standard Operating Procedures (SOPs) while eliminating manual signatures and paper trails. They support U.S. Food and Drug Administration (FDA) Title 21 Code of Federal Regulations (21 CFR Part 11) compliance and provide the following key benefits:

- User-defined development cycle for easy process control management and compliance
- Comprehensive version history and audit trail for system protection and accountability
- User-defined electronic signature qualification

This solution also provides detailed check-in and checkout facilities to protect the change control process.

Features unique to QVCS, not contained in a manual system, include qualification lifecycle support, version control traceability, support of a version control system toolbar, and a full version history and audit trail. The history and audit trail allow the system to keep detailed records that meet FDA regulations and GAMP guidelines.

Honeywell's technical excellence and clause-by-clause analysis of 21 CFR Part 11, 210 and 211 have helped develop a system that reflects functionality and usability, while delivering a groundbreaking best-in-class product that will maintain regulatory compliance and reduce the cost of compliance.

Features

PlantCruise enables biopharmaceutical companies to realize the performance advantages of a true distributed control solution at a reduced cost. This purpose-built DCS can be tailored to fit your specific control applications – regardless of their scope – and extended at any time to include personnel and assets, and even to integrate entire business operations.

Built-in Function Blocks: Designed to suit pharmaceutical applications and DCS requirements with specific function blocks, as well as support Custom Algorithm Blocks for building user-defined algorithms and data structures.

Pre-built Templates: Solution pack with a wide range of templates ideal for general control applications.

Application Development Toolkit: Develop custom applications that communicate with PlantCruise through the Network Application Programming Interface (API), Server API, Open Database Connectivity (ODBC) Data Exchange, Server Automation Object, etc.

FTE: Reliable, industrial-grade network providing multiple communication paths between nodes – thus eliminating all single points of failure –and utilizing commercial Ethernet technology for lower costs.



The robust Experion S8 C300 controller

C300 Controller: The Experion C300 controller operates Honeywell’s deterministic Control Execution Environment (CEE) software, which executes control strategies on a consistent and predictable schedule.

Direct Station: Powerful operator station functions as a client to the PlantCruise Engineering Server, and at the same time, allows direct access to the C300 controller for process data, alarms and messages.

Safe Operations: In collaboration with the Abnormal Situation Management (ASM®) Consortium, Honeywell has developed safe operator functions like Procedural Operations to reduce incidents related to improper execution of operating procedures. It has also created alarm handling and display layouts to improve overall operator response to abnormal conditions.



Experion PPC for Field Operations

Experion PPC: Experion® PPC (Panel PC) is an industrial grade Touch Panel PC that extends Experion HMI for field operations and control at machine and/or process level. This robust, easy to maintain hardware is built on open industry standards and provides the proven Experion User Interface with comprehensive data integration capabilities and consistent HMI experience that improves operator effectiveness.

With PlantCruise, pharmaceutical manufacturers can achieve significantly enhanced batch capabilities. They can run an S88-compliant batch system entirely on PlantCruise’s C300 controller, providing faster and more reliable batch operations compared to a conventional server-based system. Class-based recipes enable reuse of recipes and help reduce the cost of recipe engineering, maintenance, and testing.

Specific benefits of this approach include:

- Increased batch execution availability by executing a complete procedure in a redundant controller environment
- Increased throughput by reducing batch execution times and latency between applications levels

- Improved operator usability through display integration and interactive instructions
- Covers all levels of sequence functionality in the ISA S88 model
- Reduces recipe maintenance through equipment-independent master recipes

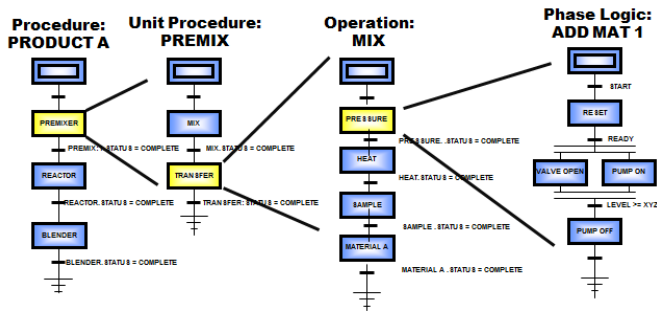

Sample Batch Procedures

In addition, PlantCruise provides a comprehensive set of SCADA capabilities, including new equipment-based configuration to dramatically reduce engineering effort. Honeywell's HMIWeb Solution Pack also provides a ready-to-use library of standardized objects to build ASM[®]-compliant displays, enabling quick project implementation and effective plant operation.

By employing PlantCruise's tightly integrated architecture, users only need one server or a pair of servers for both DCS and SCADA systems. No additional hardware costs are necessary for integrating SCADA functions or third-party systems.

The PlantCruise solution also allows pharmaceutical operations to implement centralized or remote control of geographically separated segments of production through its DSA. No additional hardware and networks are required to connect multiple control systems; users can leverage integrated engineering configuration, as well as greater flexibility to implement control where they want it.

Complementary Offerings

Field Device Manager (FDM)



FDM used for Honeywell STT25H Temperature Transmitter

Honeywell Field Device Manager (FDM) simplifies maintenance tasks, saves time and provides the flexibility and scalability to perform complete device configuration and management tasks in the plant environment through smart plant instrumentation.

FDM is a centralized asset management system for remote configuration and maintenance of smart field devices based on HART, PROFIBUS and Fieldbus Foundation protocols. FDM is integral to supporting Experion-connected devices, yet it easily handles non-Experion networks.

FDM supports a large number of devices through FDM clients connected to multiple, distributed FDM servers. With complete command and control of all instruments through the plant, FDM saves time by greatly reducing the number of field trips that would otherwise be required. By simplifying and reducing effort normally involved in plant debugging, FDM improves overall asset effectiveness.

Experion Mobility Solution

Honeywell offers the widest range of visualization, collaboration and browser based solutions in the industry. The following offerings are available for secure remote access to Experion displays, Experion history, trends and alarms:

- Experion Alarm Pager for alarms and events per email or sms alerts
- Experion Mobile Station- A mobile workforce productivity solution that enables users to access critical process information, alarms, historical data, graphics and other key functions directly from the field, via a wireless connection.
- Experion eServer for read-only access to custom graphics and trends by casual users
- Experion RESS node for secure Station access from desktop, tablet and laptop devices - provides remote access to all

Station functions and Engineering tools

- Experion Collaboration Station – Intuitive large touch screen-based dashboard that benefits any modern control room and remote support team



Experion Mobile Station

Wireless Solutions

Honeywell is a leader in industrial wireless technology. Our portfolio includes wireless solutions for low-cost process monitoring, critical process control, virtual control rooms, operator productivity tools and resource tracking. Honeywell's OneWireless™ network provides manufacturers with one optimized multifunctional network that supports many applications with comprehensive end-to-end security. Supporting a mobile workforce, Mobile Station technology, an extension of

Honeywell's Experion PKS, enables engineering, operations and maintenance personnel to safely capture and share process data locally at the source. OneWireless focuses on applications that improve operations including:

- Capturing valuable plant information in places where it was not previously possible, utilizing mobile and wireless technologies that automate field operator activities and bring the control room to the field.
- Providing real-time, accurate and reliable process and asset data faster and at lower costs than traditional wired sensors.

OneWireless Network Architecture

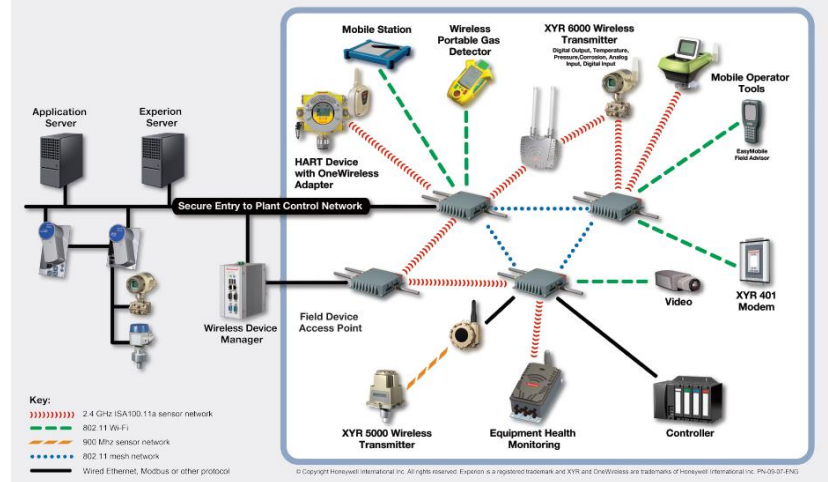

Why Honeywell?

Choose PlantCruise and know that Honeywell stands behind you over the life of your investment. Our channel partners are fully trained, authorized and experienced to implement and support your project – whether small or large, new or an expansion. You can rely on readily available local service when you need it.

In addition, PlantCruise users have full access to Honeywell's Global Technical Assistance Center (GTAC) for product support and consulting. Our experts can help you resolve issues in a timely manner and keep your system running at peak performance.

For More Information

To learn more about how Honeywell's PlantCruise by Experion solution can optimize your performance, visit www.plantcruise.com or contact your Honeywell account manager.

Honeywell Process Solutions

1250 West Sam Houston Parkway South
Houston, TX 77042

Honeywell House, Arlington Business Park
Bracknell, Berkshire, England RG12 1EB UK

Building #1, 555 Huanke Road, Zhangjiang
Hi-Tech Park, Pudong Shanghai, China

www.honeywellprocess.com

Experion® and Profit® are registered trademarks of Honeywell International Inc. All other trademarks are the property of their respective owners.

©2017 Honeywell International, Inc.

SO-17-02-ENG
Sept 2017
© 2017 Honeywell International Inc.

-Page 6-

Honeywell