

Duct Adapter Mounting Kit Quick Start Guide

Installation Instructions for P/N 1283K1090

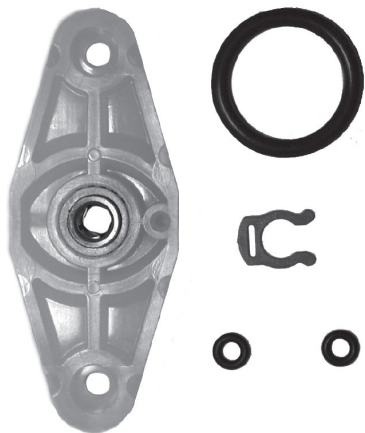

Introduction

This duct mounting adapter kit is designed for easy installation and insertion of sample tubing directly into ducts from 3 to 16 inches (8 to 40 cm) in diameter. The adapter is for use with gas detection systems which actively draw sample air into the monitoring instrument (System 16, Model CM4TM, LIFELINE® Series extractive transmitters, Vertex™, Midas® and Satellite extractive units). Use Teflon® FEP 3/16-inch (4.7 mm) I.D. x 1/4-inch (6.35 mm) O.D. sample tubing.

The duct mounting kit includes a duct adapter, O-rings, locking clip, rivet nuts, and screws. Figure 1 shows the adapter kit components. The installation uses a minimum number of holes drilled into the ductwork. A hole diagram is provided in this technical note (refer to Figure 2 on reverse).

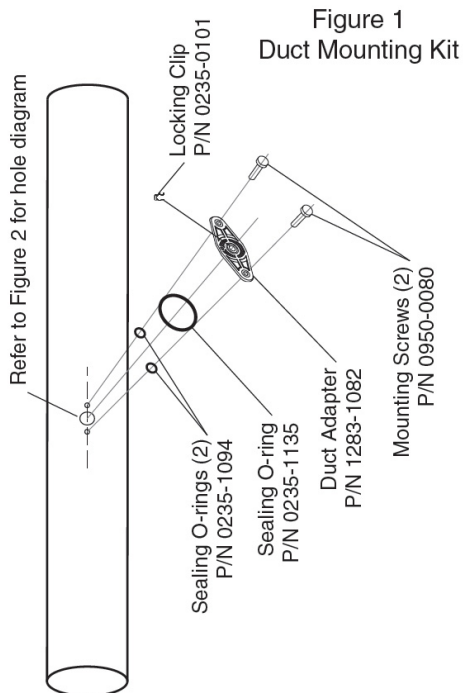

Maximum Duct Flow

The following table lists the maximum permissible airflow inside the ducts which will allow the duct adapter to operate effectively. The maximum flow is based on the vacuum level of an active sampling system (System 16, Model CM4TM, LIFELINE® Series extractive transmitters, Vertex™, Midas® and Satellite extractive units). The maximum flow does not take into account the pressure differential, which exists inside ducts to create the air flow. This pressure actually increases the flow values listed in the table. A safety factor of 2 was used in the flow calculation. This accounts for the possibility of leaks and various flow restrictions such as tubing kinks, dirt accumulation inside the tubing, tight bend radius on the tubing, etc.

Maximum Flow Rates	
Duct Size (inches)	Maximum Flow (CFM)
3	700
4	1,200
6	2,700
8	4,700
10	7,400
12	10,700
14	14,500
16	19,000

Note: Air flow in CFM equates to a flow velocity of approximately 230 ft/sec.

Installation

There are two ways to install the duct adapter. Option 1: Use #8 sheet screws and sealing O-rings, as shown in Figure 1. Option 2: Use rivet nuts. Rivet nuts can be installed on wall thicknesses of 0.020 to 0.080 inch (0.5 to 2.0 mm).

Drill one 7/8 inch (22 mm) hole and two smaller holes. When using screws, the smaller holes are 9/64 inch (3.6 mm). When using rivet nuts, the smaller holes are 17/64 inch (6.7 mm). The sheet screws or rivet nuts are the only installation intrusion to the ductwork. A hole diagram is shown in Figure 2 (on reverse).

Refer to Figure 3 (on reverse) for an installation drawing using sheet metal screws. Make certain the O-ring and sealing O-rings are in place before using the self-tapping screws to mount the adapter to the duct.

To install a rivet nut, use installation

tool P/N 0400-0089 (with #8 mandrel). Sealing O-rings are not used with rivet nuts. In addition, machine screws #8 are used to secure the duct adapter to the rivet nuts.

After mounting the adapter, insert the sample tubing into the duct adapter. Use the locking ring on the quick-connect fitting to secure the sample tubing in the adapter.

Sample Tube Orientation

Some sampling systems require the duct flow pressure to obtain the sample via Pitot tube or orienting the tubing directly into the duct flow. Due to the nature of Honeywell Analytics instruments' flow systems, which use internal pumps, specific orientation of the sample tubing (i.e., angled toward, away from, or perpendicular to the gas stream) is of little concern. The relatively low static pressure in the duct compared with the much higher standard pressure drop in the instruments minimizes the effect of tubing orientation. The smallest of the pumps in the instruments listed in this guide will experience only a 1.78% drop in performance per inch W.C. deviation from atmospheric pressure. Further, this minor effect is all but eliminated if the instrument's exhaust is routed back to the same duct or another location with similar static pressure, thereby canceling the effect on the sample point.

Holes (2 places)

for sheet metal screws: 9/64 inch (3.6 mm)

for rivet nuts: 17/64 inch (6.7 mm)

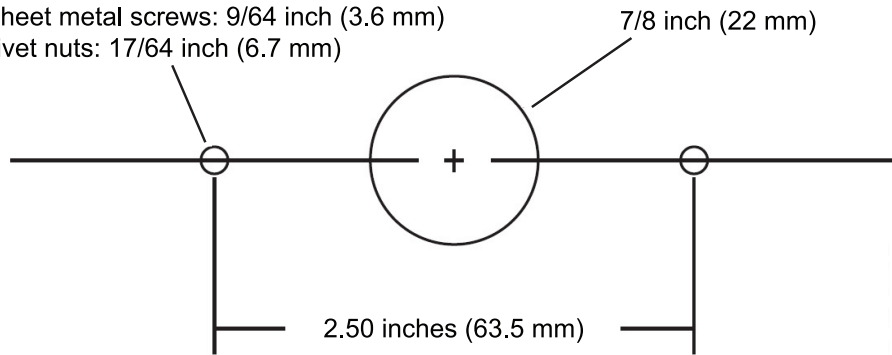

Note:

Printers and photocopiers can vary image sizes, therefore this image may not be an exact 1:1 scale.

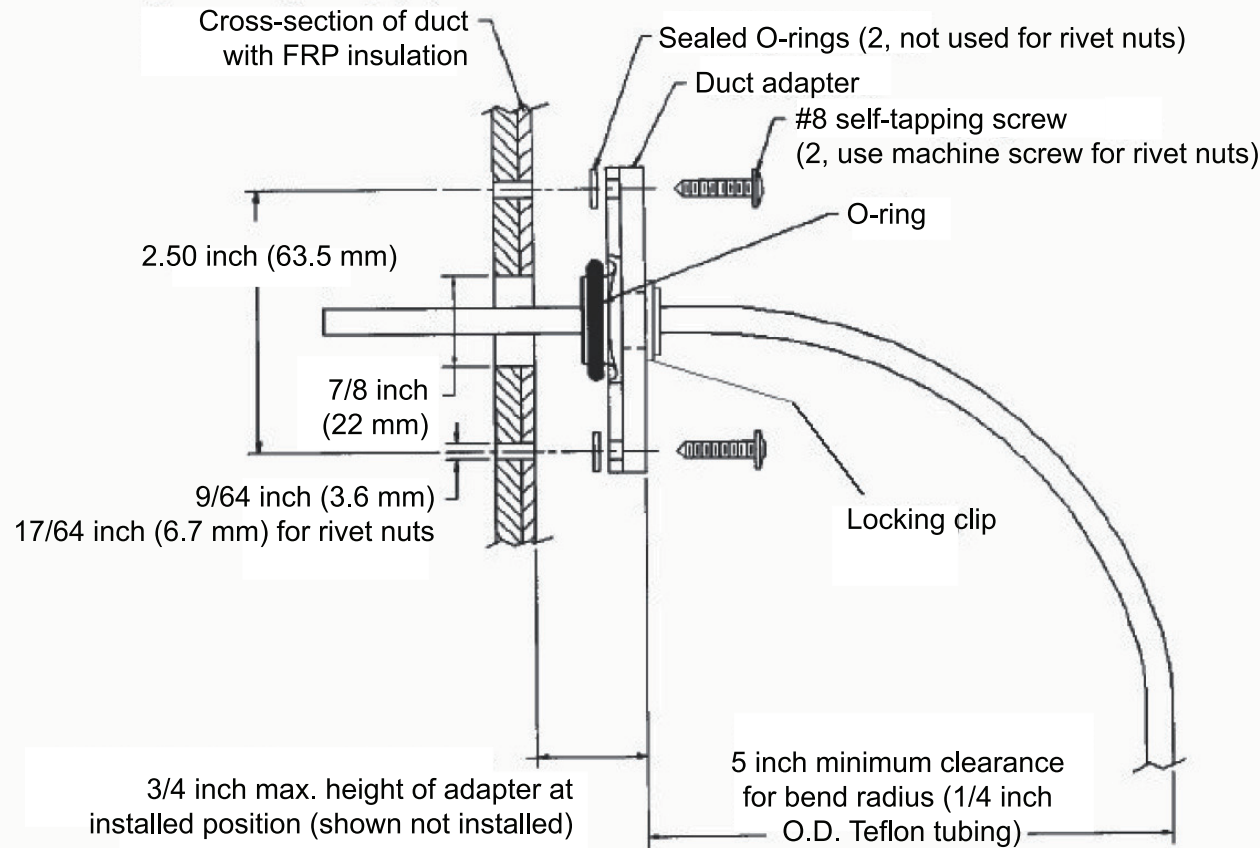

Find out more
www.honeywellanalytics.com

Americas
Honeywell Analytics
405 Barclay Boulevard
Lincolnshire, IL 60069
Tel: +1 847 955 8200
Toll free: +1 800 538 0363
Fax: +1 847 955 8208
detectgas@honeywell.com

Europe, Middle East, and Africa
Life Safety Distribution AG
Wilstrasse 11-U11
CH-8610 Uster
Switzerland
Tel: +41 (0)1 943 4300
Fax: +41 (0)1 943 4398
gasdetection@honeywell.com

Asia Pacific
Honeywell Analytics
#508, Kolon Science Valley (I)
187-10 Guro-Dong, Guro-Gu
Seoul, 152-050 Korea
Tel: +82 2 2025 0300
Fax: +82 2 2025 0329
analytics.ap@honeywell.com

Technical Services
ha.global.service@honeywell.com
www.honeywell.com

Honeywell

Part No. 1998-0292
Revision 6, August 2011
©2011 Honeywell Analytics