



**Reliable infrared open path  
gas detection for ducts**

# Cross-Duct Technology



## Applications include

- Control rooms
- Personal refuge areas
- Turbine enclosures

## Features & benefits

- Fast speed of response provides earliest warning
- High sensitivity allows low alarm set points
- Alignment free design makes installation simple
- Duct flex and vibration tolerance keeps the system online
- Integral functional gas test facility allows for simple system check
- Contamination resistant optics reduce the need for unscheduled maintenance
- Immune to catalytic poisons
- Works in inert atmospheres

## Based on the proven open path design, Searchline Excel Cross-Duct was developed in response to the unique requirements for monitoring in HVAC ducting and Turbine Enclosures.

Searchline Excel Cross-Duct delivers the highest speed of response at low alarm set points over a wide temperature range

With continuous improvement and the highest quality manufacturing and control processes, Honeywell Analytics Searchline Excel Open Path flammable gas detector provides best in class gas detection. Searchline Excel is often the chosen primary flammable gas detector in conjunction with Searchpoint Optima Plus as complimenting flammable point detection.

Cross duct flammable gas detectors compliment other system gas protectors such as toxic gas detection, providing a fast and effective protection to gas ingress into ventilation ducts.



## Modbus digital output - know before you go!

Searchline Excel is also available as a kit with the XNX Universal Transmitter, featuring both a local HART® port and HART® over 4 to 20mA as standard. These solutions allow configuration of the Searchline Excel through the XNX user interface or using a compatible HART® hand-held interrogator one device. Alternatively, an intrusive

connection to the Searchline Excel using an SHC-1 hand-held interrogator together with an SHC-1 protection device module can be made in applications that allow such operations.

The multi drop Modbus capability can enable significant savings in installation and cabling costs. A single comms cable can be run between up to 32 detectors instead of the

usual 'single run' required for each detector. Additionally, the 2 way digital communication protocol allows configuration, warning and fault diagnosis information to be communicated back to the control room. This reduces servicing and maintenance costs as the operator can diagnose the state of any individual unit before deciding to send anyone into the field.

# Technical Summary

## Searchline Excel Cross-Duct



Specification	
<b>Available Gas Calibrations</b>	Methane (gas mixtures where methane is the main constituent (>70%) and the balance is C <sub>2</sub> - C <sub>6</sub> hydrocarbons)*
<b>Detection Range</b>	0-100% LEL
<b>Minimum Alarm Thresholds</b>	20% LEL (>0.5 to 2.5m duct width) 10% LEL (>2.5m to 5m duct width)
<b>Speed of Response</b>	T90 < 1 second
<b>Output Signals</b>	Measuring range: 4-20mA sink or source (Default current source) Over range: 21mA Warning: 3mA Beam Block: 2.5mA Inhibit: 2mA Fault: 0mA
<b>Diagnostics</b>	RS485 serial link
<b>Digital Output</b>	Modbus RS485 multi drop. (Using DX100(M) or XNX Universal Transmitter with Modbus option)
<b>Operating Temperature</b>	-40°C to +50°C (-40°F to 122°F) ambient. An internal duct temperature of up to 60°C (140°F) is acceptable, provided the ambient temperature outside the duct at the Transmitter and Receiver unit is within the operating range. Contact Honeywell Analytics for high temperature applications
<b>Operating Humidity</b>	0-99% (non condensing)
<b>Operating Pressure</b>	91.5-105.5 kPa (non compensated)
<b>Repeatability</b>	5.0% LEL (<1 metre duct width) 2.5% LEL (>1 metre duct width)
<b>Warm-up Time</b>	<1 hour (fully stabilised)
<b>Power Supply</b>	Unit: 18 to 32V dc Heated Reflector Panel: 18 to 28V dc
<b>Power Consumption</b>	Unit: 13W max. Heated Reflector Panel: 6W (nom) @ 24VDC
<b>Enclosure Material</b>	316 Stainless steel
<b>IP Rating</b>	IP66 and IP67
<b>Weight</b>	Transceiver 13kg, reflector panel 5kg (>0.5m to 2.5m duct width), 10kg (>2.5 to 5.0m duct width)
<b>Vibration</b>	2-60Hz, max ptp amplitude 1mm
<b>EMC Standards</b>	EN50270
<b>Safety Approvals</b>	<p><b>ATEX</b> Transmitter:                      Ⓜ II 2 G Ex d op is IIC T5 (T<sub>amb</sub> -40°C to +65°C) Gb                      Ⓜ II 2 G Ex d op is IIC T6 (T<sub>amb</sub> -40°C to +40°C) Gb</p> <p>Receiver:                      II 2 G Ex d IIC T5 (T<sub>amb</sub> -40°C to +65°C) Gb                      II 2 G Ex d IIC T6 (T<sub>amb</sub> -40°C to +40°C) Gb</p> <p><b>Heated Panel</b>                      ATEX: Ⓜ II 2 G Ex d IIC Gb T3 (T<sub>amb</sub> -40°C to +60°C)                      UL: Class 1, DIV 1, Groups B, C, D T<sub>amb</sub> -40°C to +60°C</p> <p><b>IECEx</b>                      Transmitter:                      Ex d op is IIC T5 (T<sub>amb</sub> =-40°C to +65°C) Gb                      Ex d op is IIC T6 (T<sub>amb</sub> =-40°C to +40°C) Gb</p> <p>Receiver:                      Ex d IIC T5 (T<sub>amb</sub> -40°C to +65°C) Gb                      Ex d IIC T6 (T<sub>amb</sub> -40°C to +40°C) Gb                      UL: Class 1 Groups B, C, D and Class 1 Zone 1 AEx d IIB + Hydrogen (Amb -40°C to +65°C)</p>

\*Contact Honeywell Analytics for other gases and approvals

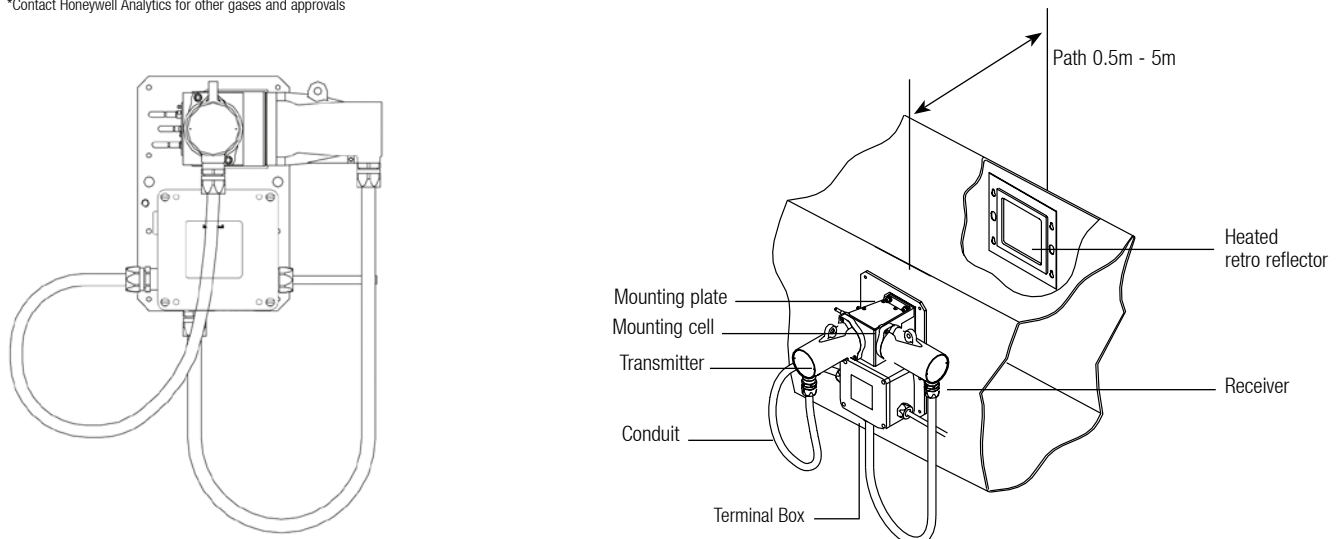

# Honeywell Analytics Gas Detection



Honeywell Analytics is able to provide gas detection solutions to meet the requirements of all applications and industries. Contact us in the following ways:

## Headquarters

### Europe, Middle East, Africa

Life Safety Distribution AG

Javastrasse 2

8604 Hegnau

Switzerland

Tel: +41 (0)44 943 4300

Fax: +41 (0)44 943 4398

gasdetection@honeywell.com

### Customer Service:

Tel: +800 333 222 44 (Freephone number)

Tel: +41 44 943 4380 (Alternative number)

Fax: +800 333 222 55

Middle East Tel: +971 4 450 5800 (Fixed Gas Detection)

Middle East Tel: +971 4 450 5852 (Portable Gas Detection)

### Americas

Honeywell Analytics Distribution Inc.

405 Barclay Blvd.

Lincolnshire, IL 60069

USA

Tel: +1 847 955 8200

Toll free: +1 800 538 0363

Fax: +1 847 955 8210

detectgas@honeywell.com

### Asia Pacific

Honeywell Analytics

Asia Pacific

#701 Kolon Science Valley (1)

43 Digital-Ro 34-Gil, Guro-Gu

Seoul 152-729

Korea

Tel: +82 (0) 2 6909 0300

Fax: +82 (0) 2 2025 0388

India Tel: +91 124 4752700

analytics.ap@honeywell.com

## Technical Support Centres

Honeywell Analytics Ltd.

4 Stinsford Road

Nuffield Industrial Estate

Poole, Dorset, BH17 0RZ

United Kingdom

Tel: +44 (0) 1202 645 544

Fax: +44 (0) 1202 645 555

Honeywell Analytics

ZAC Athélia 4 - 375 avenue du Mistral

Bât B, Espace Mistral

13600 La Ciotat

France

Tel: +33 (0) 4 42 98 17 75

Fax: +33 (0) 4 42 71 97 05

Honeywell Analytics

Elsenheimerstrasse 43

80687 München

Germany

Tel: +49 89 791 92 20

Fax: +49 89 791 92 43

Honeywell Analytics

P.O. Box-45595

6th Street

Musaffah Industrial Area

Abu Dhabi

UAE

Tel: +971 2 554 6672

Fax: +971 2 554 6672

EMEA: HAexpert@honeywell.com

US: ha.us.service@honeywell.com

AP: ha.ap.service@honeywell.com

[www.honeywellanalytics.com](http://www.honeywellanalytics.com)

[www.raesystems.com](http://www.raesystems.com)

**Honeywell Analytics**  
Experts in Gas Detection

**BWF**  
Technologies  
by Honeywell

**RAE**  
SYSTEMS  
by Honeywell

### Please Note:

While every effort has been made to ensure accuracy in this publication, no responsibility can be accepted for errors or omissions. Data may change, as well as legislation, and you are strongly advised to obtain copies of the most recently issued regulations, standards, and guidelines. This publication is not intended to form the basis of a contract.

13463\_H\_Searchline Excel Cross Duct\_DS01153\_V1\_EMEA

02/15

© 2015 Honeywell Analytics

**Honeywell**