

COMBISAFE®

UNIVERSAL STAIR™



USER INSTRUCTIONS

Contents

GENERAL	3
Introduction	4
COMPONENT RECOGNITION	5
Connectors	5
ASSEMBLY	6
Basic assembly	6
ALTERNATE HEAD CONNECTORS	9
For connection to Scaffold tubes of diameter 48.3 mm	9
Connection to horizontal surfaces	9
Connection to 48.3 mm tubes and timber joists less than 50 mm width	9
Connection to system scaffold transoms	9
TECHNICAL DATA	10
Model information	10
Stair Assemblies	10
Guardrail Units	10
Hanger Brackets	10
Stair Guardrail Requirements	10
Model geometry	11
Model Application Range	11
Tread details	11
Space requirement	12
STRUCTURAL PERFORMANCE DATA	15
Structural performance data. Safe working loads	15
TYPICAL LAYOUTS	16
Typical Layout 1, Parallel to scaffold	16
Typical Layout 2, Perpendicular to scaffold	17
SPECIFIC RISKS & HAZARDS	18
During Installation	18
Following Installation	18
Inspection and maintenance	18
Inspection	18
Maintenance	18
DELIVERY AND STORAGE	18
Minimum folded height	19
Pack details for storage and transportation	19

© 2010 Combisafe International AB – UNIVERSAL STAIR-EN Subject to changes

General

Every year 100's of people die and 1000's suffer a serious injury as a result of a fall from height in the global construction workplace. Indeed falls from height are the most common cause of fatal injury.

In many countries statutory regulations apply to Work at Height. For example in the UK the Work at Height Regulations 2005 came into effect on 6 April 2005. The Regulations apply to all work at height where there is a risk of a fall liable to cause personal injury.

The Regulations place duties on employers, the self-employed, and any person that controls the work of others. The Regulations do not apply to the provision of paid instruction or leadership in caving or climbing by way of sport, recreation, team building or similar activities.

As part of the Regulations, duty holders must ensure:

- all work at height is properly planned and organised;
- those involved in work at height are competent;
- the risks from work at height are assessed and appropriate work equipment is selected and used;
- the risks from fragile surfaces are properly controlled; and
- equipment for work at height is properly inspected and maintained.

The Regulations include schedules giving requirements for existing places of work and means of access for work at height.

The regulations provide a simple hierarchy for managing and selecting equipment for work at height, you must:

- avoid work at height where you can;
- use work equipment or other measures to prevent falls where you cannot avoid working at height; and
- where you cannot eliminate the risk of a fall, use work equipment or other measures to minimise the distance and consequences of a fall should one occur.

The ideal means of access for any work at height is a purpose-made stair tower, but previously these have been time-consuming and thus costly to build in traditional scaffolding.

System scaffold stairs are available, but they are made in fixed lift heights which make them unsuitable for traditional scaffolds. They require the use of the system to build the complete tower and relatively few scaffold companies have system kit in their inventories.

These difficulties are now overcome by the COMBISAFE UNIVERSAL STAIR range which can be used for vertical access within scaffolds or falsework structures. A range of attachments are available enabling connection of the stair units to scaffold tubes, system scaffold transoms, timber floors and slab edges.

UNIVERSAL STAIR is a simple self-contained product which is easy to store packed flat and can be collected or delivered on small vehicles including vans for the smaller models. Product selection is easy, depending only on the range of lift heights required, and users have the assurance that all models, in all possible positions, are fully compliant with regulations. Non-scaffolding users will find the UNIVERSAL STAIR easy to use, since there are no special skills involved in producing a first-class result.

The COMBISAFE UNIVERSAL STAIR is classified Class B compliant to EN12811.

Introduction

The UNIVERSAL STAIR is a range of self-contained, preassembled aluminium stair units, flat packed, which automatically adjust to a wide range of lift heights, making them ideal for use in tube and fitting scaffolds. Vitally important, the COMBISAFE UNIVERSAL STAIR is fully-compliant with EN12811 for all possible configurations

Component recognition

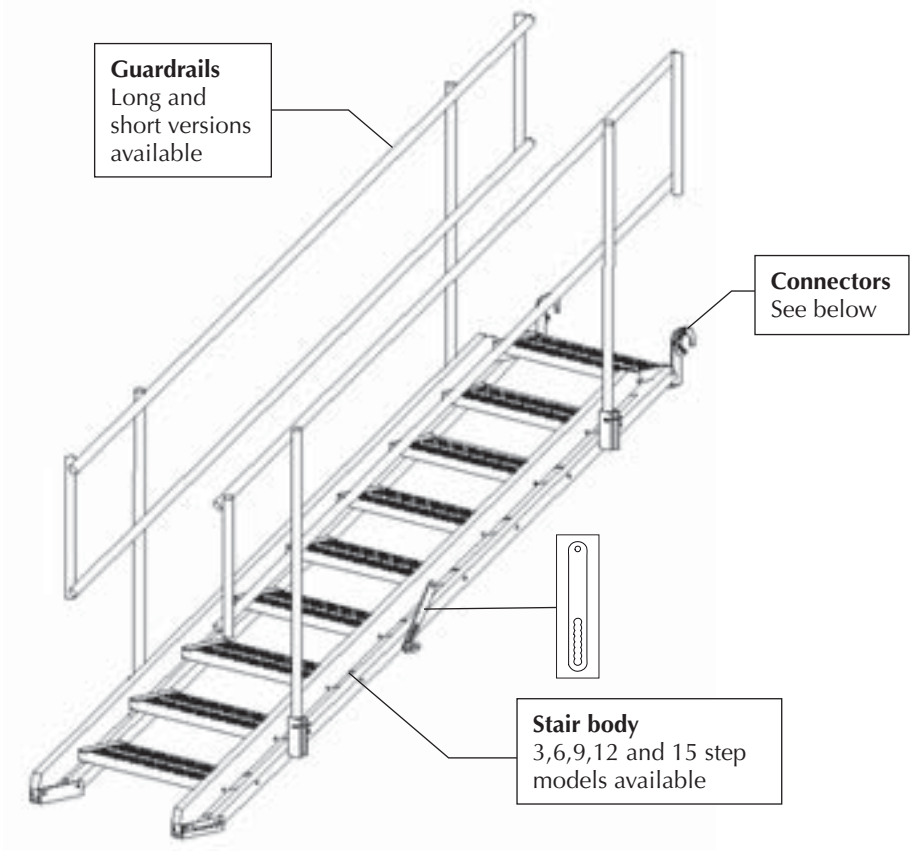

Connectors

Supplied with scaffold hooks as standard. Options available for concrete slabs, timber joists and system scaffolds.

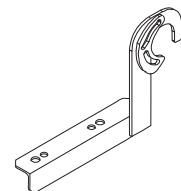

Scaffold Hook with gravity lock

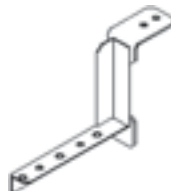

Slab Adaptor



Tibe Adaptor



Kwikstage Adaptor

Assembly

Basic Assembly

STAGE 1: Connect stair to tube or surface. Ensure locking device is engaged over tube.

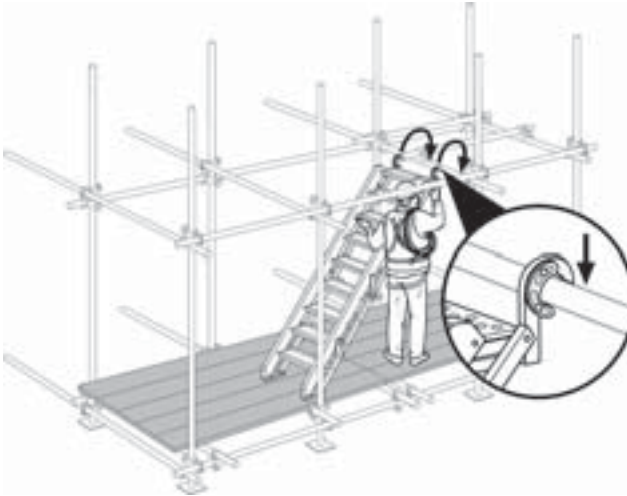

STAGE 2: Disengage wedges and insert guard rails into side mounted pockets.

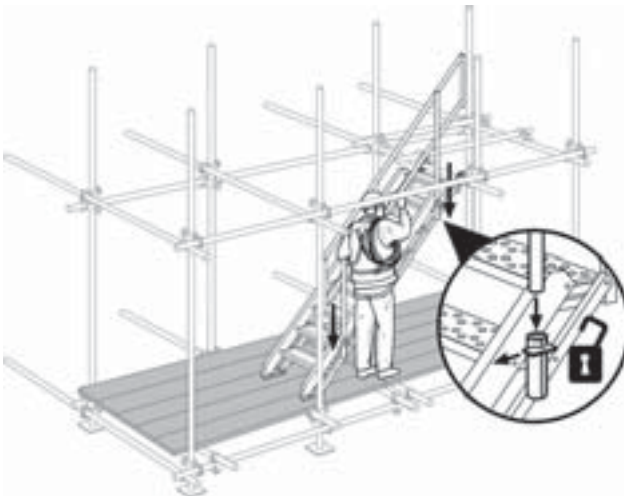

STAGE 3: Push/pull guard rails to articulate stairs and to level treads.

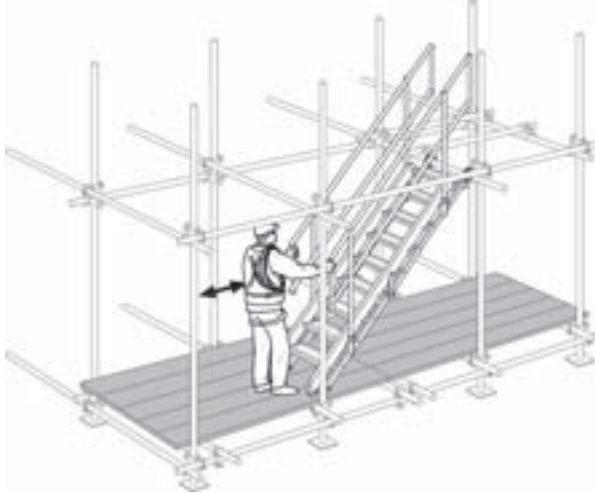

STAGE 4: Using a suitable lever or podger, lock the stair eye bolts, tacking care to enter the eye bolt register into the hole in the locking stay. It is only necessary to tighten by 1/4 turn.

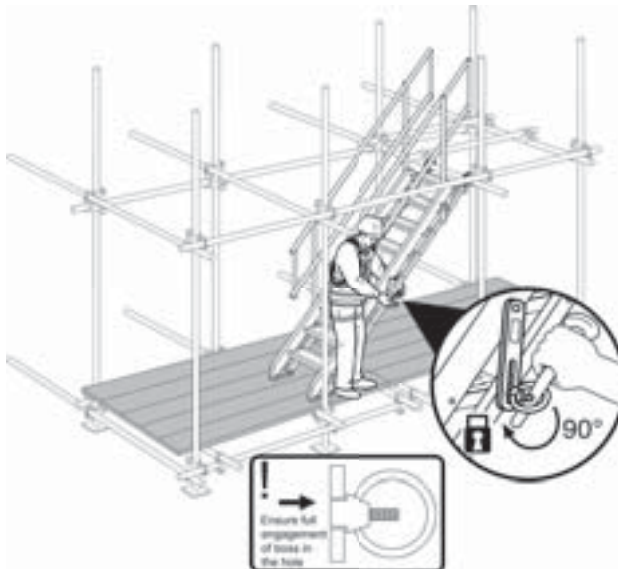

STAGE 5: Lock the guard rails using integral wedge fastening, using a hammer to tighten.

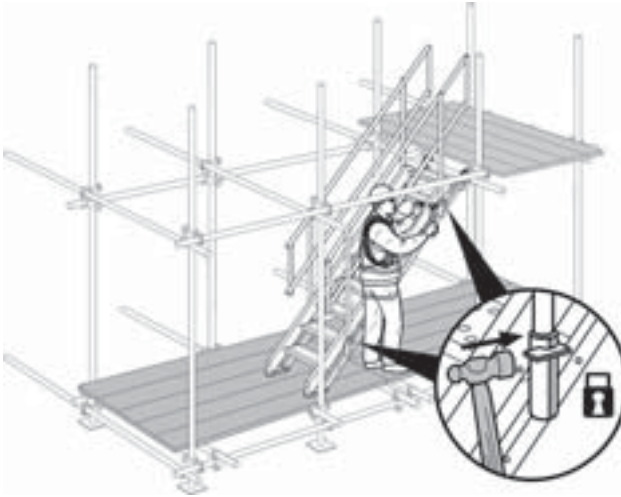

NOTE

Suitable ppe should be worn during all operations!

Alternate head connectors

For connection to Scaffold tubes of diameter 48.3 mm.

Use bracket Part 22130001. Note this is the standard bracket supplied with each stair.

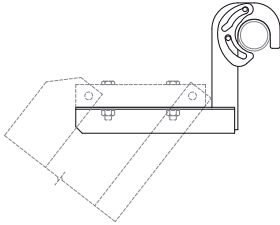

Connection to horizontal surfaces with slab adaptor.

Use Part 22130002 fixed with screws or nails into load bearing surface.

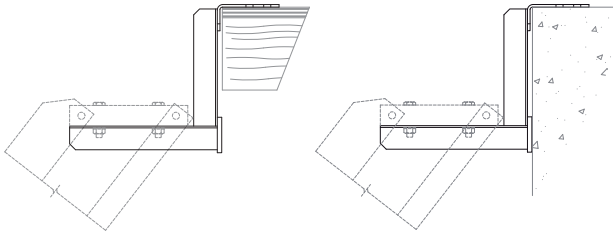

Connection to 48.3 mm tubes and timber joists less than 50 mm width.

Use Part 22130004.

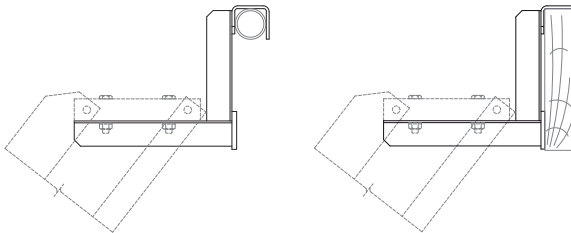

Connection to system scaffold transoms.

For Kwikstage batten transom use Part 22130003

For Cuplok Omega Transom use Part 22130005

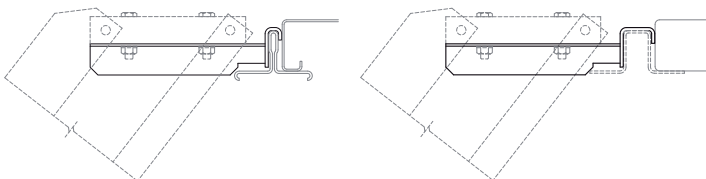

Technical data

Model information

Stair Assemblies

Part No:	Description	No. of Steps	Comments	Weight
22110001	Model 1	3	Stair bodies only, without guardrails, Scaffold hooks inclusive	11.9 kg
22110002	Model 2	6		19.7 kg
22110003	Model 3	9		29.8 kg
22110004	Model 4	12		39.2 kg
22110005	Model 5	15		47.0 kg
22100002	Model 2	6	All guardrails and scaffold hooks inclusive	29.7 kg
22100003	Model 3	9		42.0 kg
22100004	Model 4	12		59.2 kg
22100005	Model 5	15		81.4 kg

Guardrail Units

Part No:	Description	Weight
22120001	Guardrail, Short	5.0 kg
22120002	Guardrail, Long	6.1 kg

Hanger Brackets

Part No:	Description	Weight
22130001	UNIVERSAL STAIR scaffold hooks (pair)	2.0 kg
22130002	UNIVERSAL STAIR slab hanger (pair)	2.9 kg
22130003	UNIVERSAL STAIR KS hanger (pair)	3.9 kg
22130004	UNIVERSAL STAIR LR hanger (pair)	2.9 kg
22130005	UNIVERSAL STAIR OM hanger (pair)	4.9 kg

See section 3.2 above for details of bracket use.

Stair Guardrail Requirements

Model Number	Number of guardrails	
	Short	Long
1	–	–
2	2	–
3	–	2
4	4	–
5	2	2

Geometry

Model geometry

Model Application Range

Model Number	Application Range		
	Min H(m)	Max H(m)	
1	0.56	0.83	
2	0.95	1.47	
3	1.37	2.17	
4	1.80	2.87	
5	2.23	3.57	

Note the above table relates to application range when using hanger bracket 22130001 only.

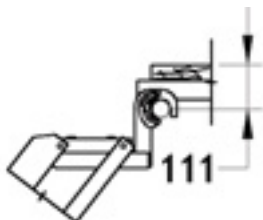

Additional height H using bracket 22130001.

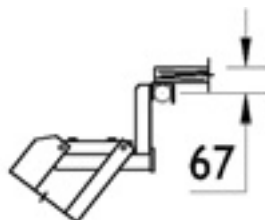

Additional height H using bracket 22130004.

Tread details

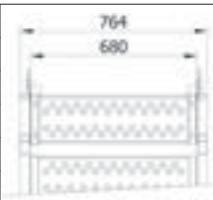
Model	Number of Treads	Tread Width (m)	
1	3	0.68	
2	6	0.68	
3	9	0.68	
4	12	0.68	
5	15	0.68	

Space requirement

Model 1

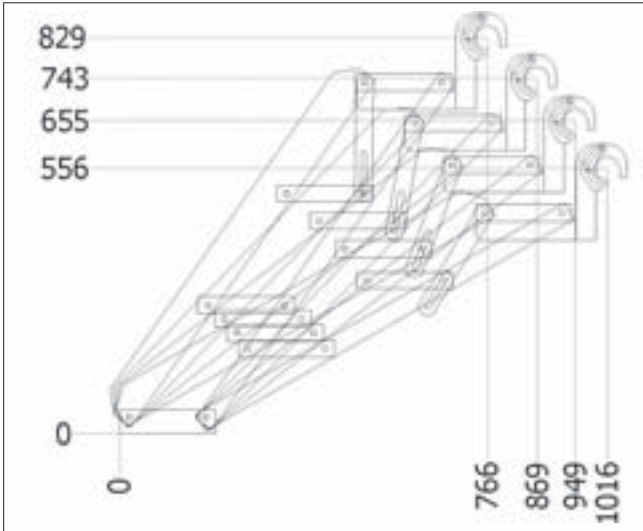

Model 2

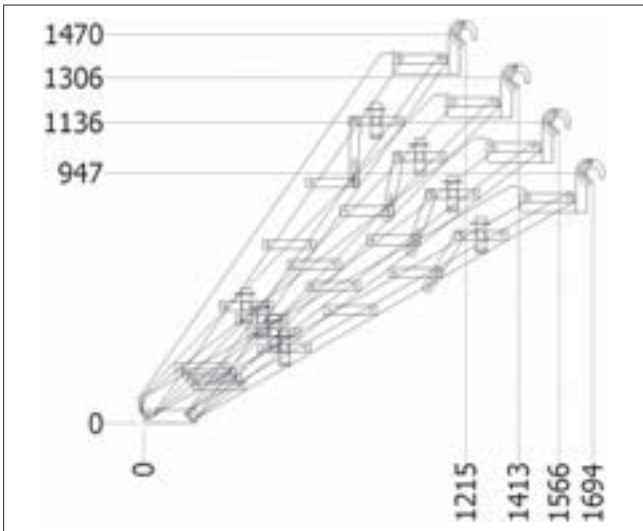

Model 3

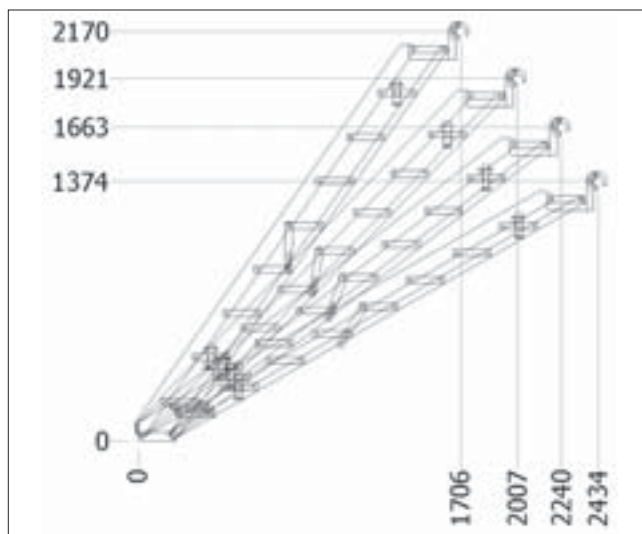

Model 4

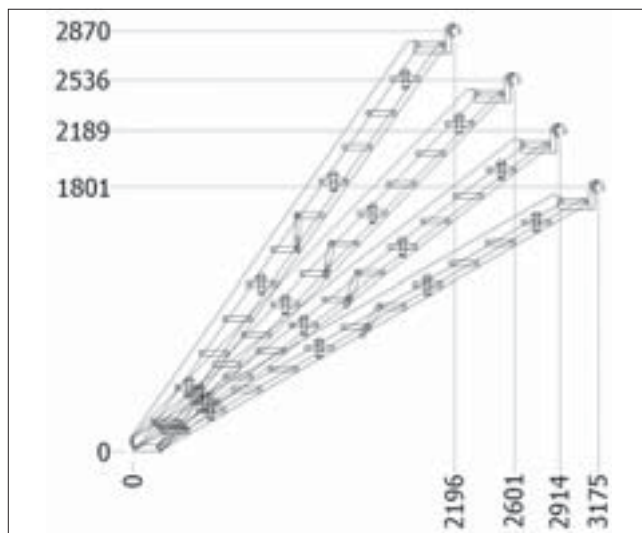

Model 5

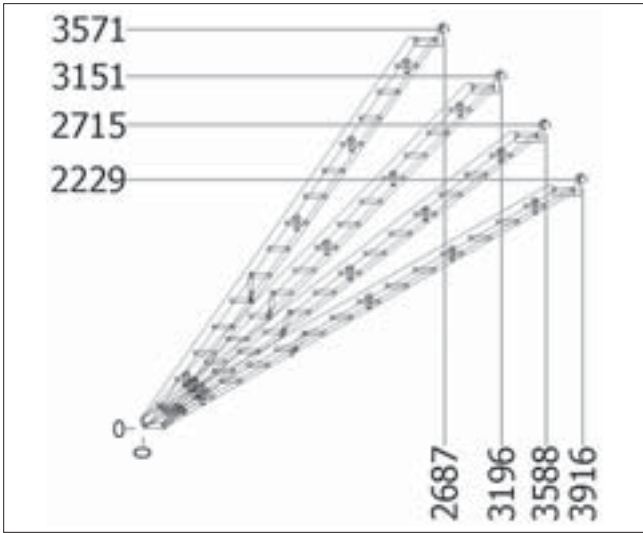

Structural performance data

Structural performance data. Safe working loads

Model Number	Uniformly distributed load kN/m ²	Point Load kN
1	>2.5	1.5
2	>2.5	1.5
3	>2.5	1.5
4	>2.5	1.5
5	2.5	1.5

Note: Uniformly distributed load case assumes every tread loaded simultaneously. Point load case is maximum per tread.

Typical layouts

Typical Layout 1, Parallel to scaffold.

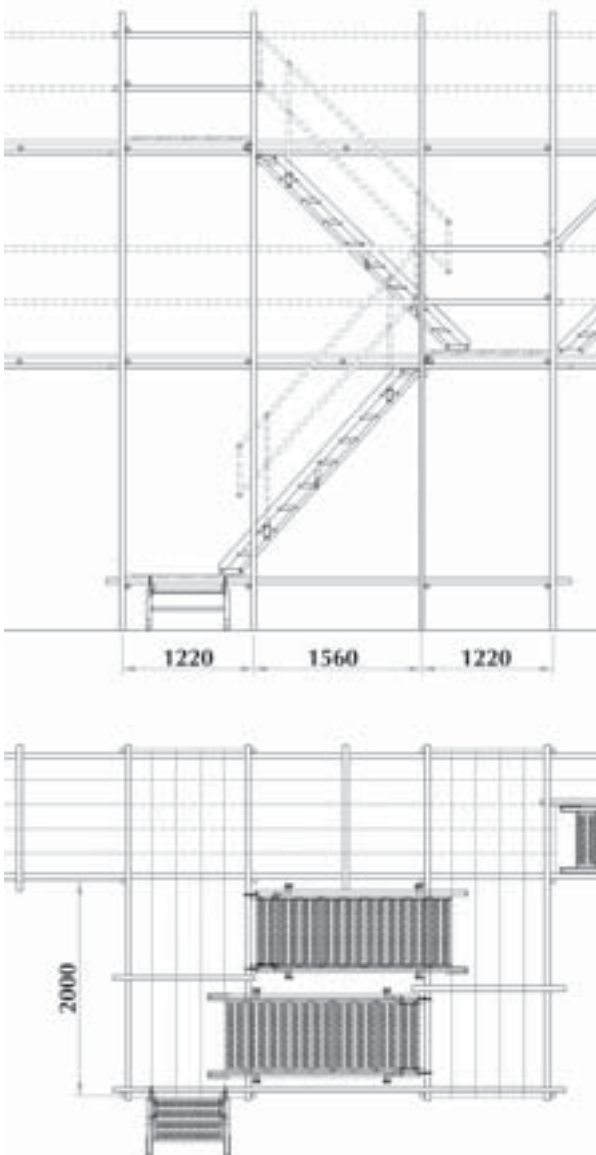

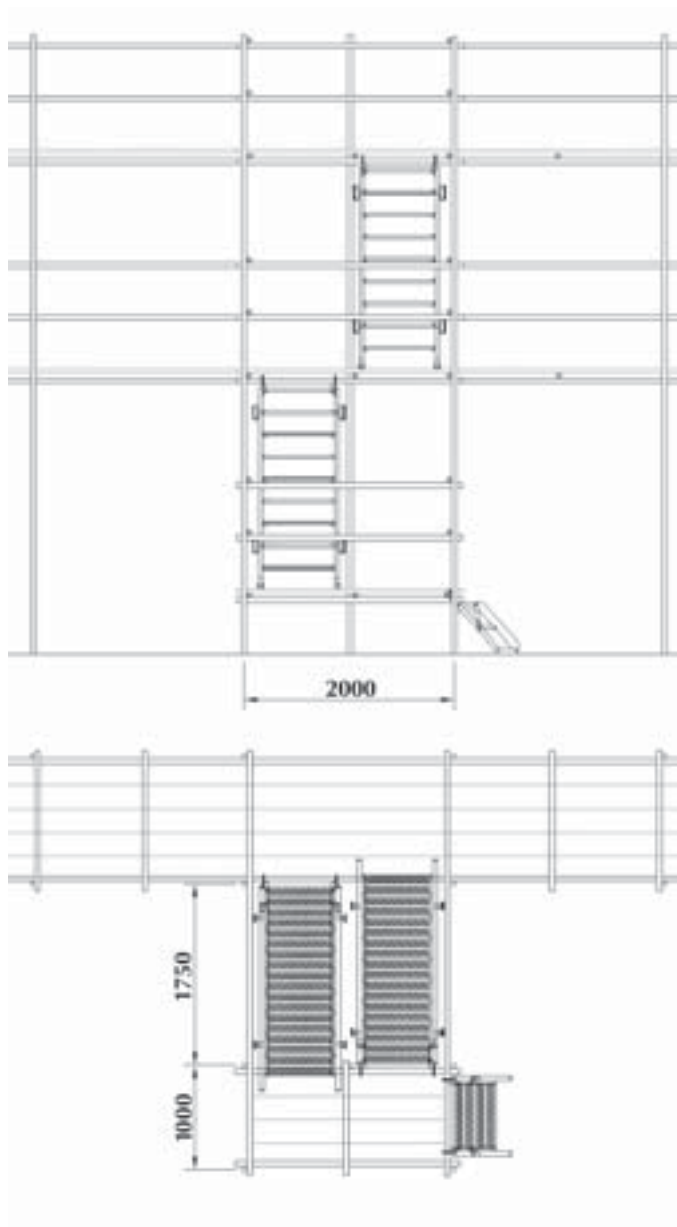
Typical Layout 2, Perpendicular to scaffold.

Specific risks & hazards

During Installation

Appropriate PPE should be worn at all times whilst installing the UNIVERSAL STAIR. A minimum recommendation is gloves, steel toe cap boots and a hard hat. Manual handling, lifting and placement of the UNIVERSAL STAIR requires a minimum of 2 men above Model 2.

Do not place fingers under the treads at the tread/stringer intersection whilst adjusting the stair. This gap opens and closes during adjustment prior to fixing of the locking stay. Ensure that all guardrails and toe boards are fitted and secured at each landing position.

Following Installation

Keep at least one hand on a guard rail at all times whilst traversing the stairway. Do not run entering, traversing or leaving the stairway as this will greatly increase your chances of tripping.

Ensure that the stair treads are kept free from debris and materials. Materials are not to be stored on the stairs at any time.

Ensure that the stair treads are kept free from grease or oil spillages as this will increase the chances of slipping.

Ensure that the side mounted locking stays are firmly engaged at all times and are not tampered with.

Ensure that the hanging brackets are securely positioned and engaged. Some corrosive environments and extreme temperatures may affect the performance and durability of the alloy stairway. Contact Combisafe Engineering Services for advise if these are suspected.

Inspection

Inspect weekly and prior to each installation.

Checklist:

Check all bolts and nuts are in position and tight. It will be necessary to view the stair from underneath to do this.

Check that eye bolts in both locking stays are engaged and tight.

Check for looseness of bolts.

Check all treads are free from damage.

Check all stringers are free from damage.

Check upper connection hooks and bolted fixings are secure and free from damage.

Check all guard rail connection sockets for signs of damage.

Check all guard rail connection spigot welds for damage.

Maintenance



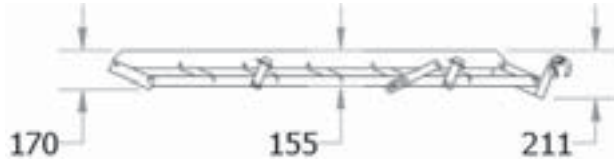

The COMBISAFE UNIVERSAL STAIR is a fully bolted construction and therefore any routine maintenance is straight forward using the minimum of tools. Tools required 17 mm spanner, 8 mm allen key.

Delivery and storage

Minimum folded height



Pack details for storage and transportation

Model No	Pack Quantities	Overall pack sizes	Pack Weight (kg)
1	8		96
2	8		158
3	8		239
4	8		314
5	8		376

The weights above do not include guardrails.

COMBISAFE[®]

Combisafe International Ltd

www.combisafe.com