

MONITOR REMOTE CONTROL FUNCTIONS FOR MULTIRAE

This technical note explains how instrument data can be transferred, and remote control functions implemented in real time, between a RAE Systems MultiRAE-family monitor and a personal computer via a HyperTerminal emulation (Point-To-Point, or P2P, protocol).

This P2P protocol is different from the wireless protocol used in the RAE Systems wireless networks. P2P and wireless capabilities are mutually exclusive and cannot be combined in one instrument.

What You'll need in order to set up the P2P connection?

You'll need the following:

- Hard wire or existing cable that shipped with the MultiRAE
- A TelNet client (communications software) in order to establish communication and to give the MultiRAE commands and display its readings and settings on the PC.

In order to operate when hardwired to a computer, the MultiRAE must be running Application Firmware v.1.14 and Sensor Firmware 1.04 or higher and configured for Point-To-Point communications. This icon should appear at the top left of the MultiRAE's display when it is running:



HyperTerminal to control serial devices isn't included in some versions of Windows <http://windows.microsoft.com/en-us/windows/what-happened-hyperterminal#1TC=windows-7> In this case a version of HyperTerminal can be found on the Internet and can be downloaded for personal use.

- If you are using Windows 7, for example, you can copy the following two programs from a Window XP computer to run HyperTerminal:

1. hypertrm.dll
2. hypertrm.exe

Important! Both of these files must be in the same folder. Start the program by double-clicking hypertrm.exe. Also note that this approach does not allow capturing a log of the session.

- You can also use one of many TelNet clients available online, including PuTTY, which is free (available at <http://www.chiark.greenend.org.uk/~sgtatham/putty/>).

CONNECTING THE MULTIRAE TO THE PC AND IDENTIFYING A COM PORT

- Connect the MultiRAE to the computer using the special RS232 Travel Charger and its mini-USB to DB9 cable (the standard MultiRAE Travel Charger and mini-USB-to-USB PC communications cable will not support P2P). If your computer does not have a DB9/RS232 serial port, use the USB-to-Serial Adapter (p/n 410-0210-000) to connect the mini-USB to DB9 cable to a PC's USB port.
- Supply power to the RS232 Travel Charger. Either attach the AC adapter to the RS232 Travel Charger, or plug its USB-A plug into an active USB port on the computer for power. The RS232 Travel Charger will not operate without a power source.

Note: Do not plug in both the USB and the AC adapter at the same time, as this may cause errors.

Follow one of the three diagrams below for power and data connection options.

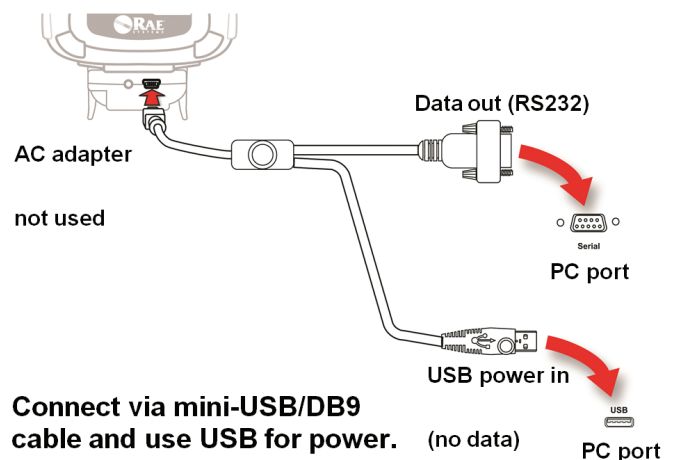

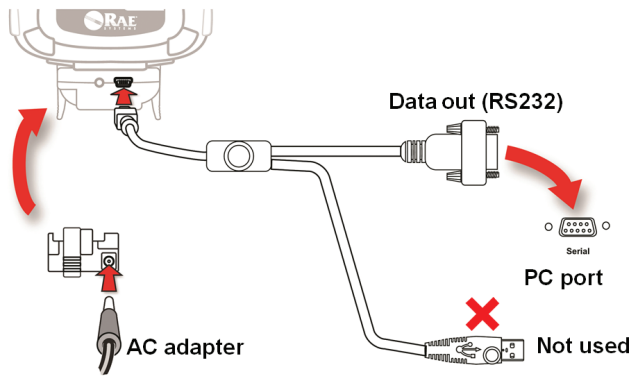

Connect via mini-USB/DB9 cable and use the AC adapter for power.

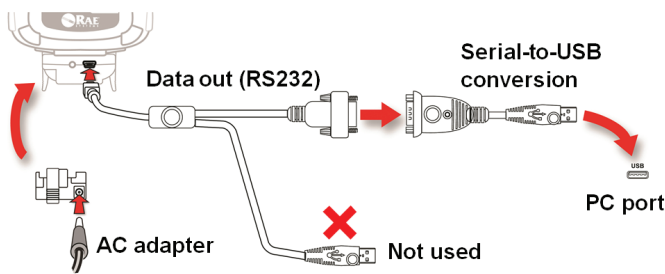

Connect via mini-USB/DB9 cable and DB9-to-USB adapter and use AC adapter for power

- Turn on the MultiRAE.
- Determine the COM (communications) port that you must use. Right-click on "Computer" Icon on your desktop and follow the path Properties >> Device Manager >> Ports (COM & LPT).
- Find the number of the COM port to which the MultiRAE is connected. The MultiRAE port is the one that reads "Silicon Labs CP210x USB to UART Bridge (COM[Port Number])."
- Close the Device Manager window.
- Start your TelNet client.

TelNet Clients

Here are setup procedures for two typical, easy-to-use TelNet clients, HyperTerminal and PuTTY. If you are familiar with others, they may be used as well.

HyperTerminal

- Start HyperTerminal.
 - a. Enter a name for the connection and click "OK."
 - b. At the "Connect To" screen's "Connect Using" option, select the port number.
 - c. Click "OK."

d. In the Properties window for your COM port, select these settings:

- Bits per second (or Baud): 9600
- Data bits: 8
- Parity: None
- Stop bits: 1
- Flow control: None

e. Click "Apply."

f. Click "OK."

The HyperTerminal window appears and the connection is active.

Test the connection by typing "S." You should see the Serial Number of your MultiRAE.

PuTTY

- Double-click the PuTTY icon to start it.
- Click "Run."
- At the PuTTY Configuration window, click the "Serial" button.
- In the box labeled "Serial line," input your COM (communications) port number.
- Set the "Speed" to 9600.
- Give your session a name by typing a name into "Saved Sessions" and click "Save." (This shortcut can be used for subsequent sessions.)
- Click "Open."

The PuTTY window with your port's name should appear.

Type "S." You should see the serial number of your MultiRAE.

Operation

The keyboard shortcuts in Table 1 display the unit's remote control readout in the terminal window.

Sensor Error/Alarm Limit Bits

A byte, comprising eight bits, is used to record the alarm limits and errors for each sensor. All of the sensors in the MultiRAE are checked remotely, and then the results are displayed when you type a shortcut.

Type "N." The names of the sensors appear.

Type "E." If everything is operating correctly, "0 0 0 0" appears. Note: the number of zeroes corresponds to the number of sensors. Therefore, if there are four sensors, you see four zeroes, etc.

Typing “?” tells the instrument to list all supported shortcut commands. For normal operation mode, the menu structure is:

MultiRAE2 P2P Menu

 C: Calculated Reading
 E: Sensor Error
 F: Firmware Version
 I*: Monitor Status
 L: Alarm Limits
 M: Model Number
 N: Sensor Name
 P: Go To Sleep
 R: Instant Reading
 S: Serial Number
 T: Interval Set
 U: Unit
 ?: Display This Menu

 Ready...

When instrument already in “Sleep” mode, then the menu structure is:

MultiRAE2 P2P Menu

 P: Wake up
 ?: Display This Menu

 Ready...

Table 1: Commands And Query Functions

Command	Function	Display (Sample)				
C	Calculated Reading	CO	49	0	5	3
		VOC	300	0	45	35
		H2S	15	0	3	3
		LEL	3	0		
		O2	20.9	19.5		
E	Sensor Alarm/Error	0	0	144	8	0
F	Firmware version	V1.14				
I*	Monitor Status	17				
L	Alarm Limits	CO	100	35	25	25
		VOC	500	100	100	50
		H2S	50	20	15	15
		LEL	50	35		
		O2	23.5	19.5		
M	Model Number	PGM-6248				
N	Sensor Name	CO	VOC	H2S	LEL	O2
P	Go To Sleep/Wake Up					
R	Instant Reading	4	6	0	0	21.4
S	Serial Number	090*****				

Table 1: Commands And Query Functions

Command	Function	Display (Sample)									
T	Interval Set (update rate to the display, in seconds) Type "T" followed by a number from 1 to 3600	0	20.9	0	0.0	0	0	0	0	0	0
		0	20.9	0	0.0	0	0	0	0	0	0
		0	20.9	0	0.0	0	0	0	0	0	0
		0	20.9	0	0.0	0	0	0	0	0	0
U	Unit (of measure)	ppm	ppm	ppm	%LEL	%					
?	Display Menu	MultiRAE2 P2P Menu C: Calculated Reading E: Sensor Error F: Firmware Version I*: Monitor Status L: Alarm Limits M: Model Number N: Sensor Name P: Go To Sleep R: Instant Reading S: Serial Number T: Interval Set U: Unit ?: Display this menu Ready...									

* Command "I" appears with Firmware V1.18 and Sensor Firmware 1.08 or higher.

Command "P" appears with Firmware V1.31 and Sensor Firmware V1.08 or higher.

(N) The first line is the names of the sensors.

(U) The second line is their units of measure.

(R) The third line shows their readings.

Keyboard Shortcuts And Query Functions

The following table shows the keys you type to query the MultiRAE, as well as the function name and a sample of what is then shown on the display.

Notes:

- Commands are not case-sensitive.
- Tab(0x09) is used to separate readings or Alarm/Error code.
- The interval between two commands will be longer than 100ms.
- For a quick view of the sensors' status (installed sensors, units of measure, and readings), type these three letters:

N U R

Here is a sample of the display:

LEL	OXY	CO	H2S	VOC
%LEL	%	ppm	ppm	ppb
0	20.9	0	0.0	0

To view the Calculated Reading, type "C." Here as an example of the output:

LEL	0	0		
OXY	20.9	20.9		
CO	0	0	0	0
H2S	0.0	0.0	0.0	0.0
VOC	170	0	0	0

To view the Alarm Limits, type "L."

Here is a sample of the Alarm Limits display:

LEL	20	10		
OXY	23.5	19.5		
CO	200	35	100	35
H2S	20.0	10.0	15.0	10.0
VOC	100000	50000	25000	10000

The information is arranged to show the sensor name, High, Low, STEL (where appropriate) and TWA (where appropriate).

Sensor Error/Alarm Limit Bits

A byte, comprising eight bits, is used to record the alarm limits and errors of each sensor. When you type the command "E," all of the sensors in the unit are checked remotely and then the results are displayed.

Table 2: Alarm/Error Codes

Alarm/Error	Code	Explanation
Over Range	1 (Bit 0)	Sensor over range error
Max	2 (Bit 1)	Sensor max (hardware saturated)
Fail	4 (Bit 2)	A failure has occurred <ul style="list-style-type: none"> • If the sensor is a PID, the lamp has failed • If the sensor is an LEL: the LEL sensor is off
High	8 (Bit 3)	High alarm limit has been reached
Low	16 (Bit 4)	Low alarm limit has been reached
STEL	32 (Bit 5)	STEL has been reached
TWA	64 (Bit 6)	TWA has been reached
Drift	128 (Bit 7)	A negative drift has occurred

Table 3*: Unit status information, a byte, comprising 8 bits

Status	Code	Explanation
Power	1	Power – 1 = Normal, 0 = Abnormal
Battery	2	Battery – 1 = Low alarm , 0 = Normal
Pump	4	Pump – 1 = Stall, 0 = Normal or Not installed
Memory	8	Datalog Memory - 1 = Full, 0 = Normal or Not installed
Sensor alarm	16	Sensor alarm, any of the sensor alarm the bit will be set, includes latched alarms.
Unit Failure	32	Unit Failure–1=Failure, 0=Normal (Not used in MR11, always return 0)
Reserve	64	Reserve as 0
Alarm Mode	128	The current setting of alarm mode. 1 - Latch 0 - Auto Reset

Examples Of How To Interpret MultiRAE Alarm/Error Codes

If the High alarm has been exceeded on sensor number one (LEL), this illustrates a reply when you type "E":

8 0 0 0 0

This tells you that the High alarm limit has been reached on the first sensor (LEL).

If the High alarm and the STEL alarm limit are reached for the second sensor (H₂S), this is the information you would see:

0 40 0 0 0
(40 = 8 + 32)

If two events occur simultaneously, the display looks like this:

8 40 0 0 0

The quickest way to identify the nature of the alarm or error is to subtract the largest numbers first.

40 - 32 = 8
32 = Bit 5 = STEL alarm
8 = Bit 3 = High alarm