

MILLER[®]

by Honeywell

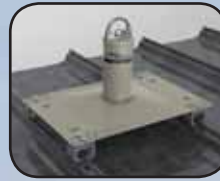
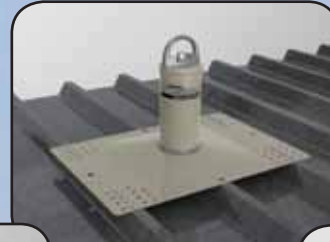

Fusion[™] Roof Anchor Posts

User Instruction Manual

Manuel D'utilisation / Manual de Instrucciones para El Usuario

Table of Contents

1.0 Purpose.....	3
2.0 General Requirements, Warnings and Limitations.....	3-4
2.1 General Fall Protection Requirements	
2.2 Warnings and Limitations	
3.0 Fusion Roof Anchor Post Diagrams and Descriptions.....	5-6
4.0 Installation of Fusion Roof Anchor Posts.....	7-20
4.1 Roof Anchor Post Assembly	
4.2 Base Installation	
4.2.1 Installation of Base to Standing Seam Roofs	
4.2.2 Installation of Base to Metal Sheathing	
4.2.3 Installation of Base to Membrane and Built-up Roofs	
4.2.4 Installation of Base to Wood Sheathing Roofs	
4.2.5 Installation of Base to Concrete Roofs	
4.2.6 Installation of Base w/o Included Hardware	
5.0 Connection to the Fusion Roof Anchor Post.....	21
6.0 Fall Clearance.....	22-23
7.0 Training.....	23
8.0 Inspection and Maintenance.....	24
Labels.....	25
Inspection and Maintenance Log.....	26
Warranty.....	27

Thank You

Thank you for your purchase of Miller Fall Protection equipment. Miller brand products are produced to meet the highest standards of quality at our ISO 9001 certified facility. Miller Fall Protection equipment will provide you with years of use when cared for properly.

WARNING

All persons using this equipment must read, understand and follow all instructions. Failure to do so may result in serious injury or death. Do not use this equipment unless you are properly trained.

Questions? CALL 1.800.873.5242

It is crucial that the authorized person/user of this fall protection equipment read and understand these instructions. In addition, it is the employer's responsibility to ensure that all users are trained in the proper use, inspection, and maintenance of fall protection equipment. Fall protection training should be an integral part of a comprehensive safety program.

Proper use of fall arrest systems can save lives and reduce the potential of serious injuries from a fall. The user must be aware that forces experienced during the arrest of a fall or prolonged suspension may cause bodily injury. Consult a physician if there is any question about the user's ability to use this product. Pregnant women and minors must not use this product.

1.0 Purpose

The Fusion Roof Anchor Post is designed to be used as a single point anchorage connector on flat roofs. Three versatile bases permit the roof post to accommodate a variety of roof structures, such as standing seam, metal sheathing, membrane and built-up roofs, wood and concrete. A D-ring anchor located at the top of the post allows for compatible connection of the user's personal fall arrest system.

The Fusion Roof Anchor Post may also be used as an intermediate (non-end, non-corner) support within an approved Miller horizontal lifeline system.

2.0 General Requirements, Warnings and Limitations

2.1 General Fall Protection Requirements

All warnings and instructions shall be provided to authorized persons/users. Warnings and instructions must be read and understood prior to using this equipment.

All authorized persons/users must reference the regulations governing occupational safety, as well as applicable standards. The Fusion Roof Anchor Post meets OSHA and ANSI Z359.1 & A10.32-2004.

Proper precautions should always be taken to remove any obstructions, debris, material, or other recognized hazards from the work area that could cause injuries or interfere with the operation of the system.

All equipment must be inspected before each use according to the manufacturer's instructions.

All equipment should be inspected by a qualified person on a regular basis.

To minimize the potential for accidental disengagement, a competent person must ensure system compatibility.

Equipment must not be altered in any way. Repairs must be performed only by the equipment manufacturer, or persons or entities authorized, in writing, by the manufacturer.

Any product exhibiting deformities, unusual wear, or deterioration must be immediately discarded.

Any equipment subject to a fall must be removed from service.

The user shall have a rescue plan and the means at hand to implement it when using this equipment.

Never use fall protection equipment for purposes other than those for which it was designed. Fall protection equipment should never be used for towing or hoisting.

Never remove product labels, which include important warnings and information for the authorized person/user.

2.2 Warnings and Limitations

System Compatibility

The Fusion Roof Anchor Post is designed for use with Miller approved components. Substitution or replacement with non-approved component combinations, sub-systems, or both, may affect or interfere with the safe function of each other and endanger the compatibility within the system. This incompatibility may affect the reliability and safety of the total system.

Miller Fall Protection requires the use of a Miller full-body harness and shock-absorbing lanyard, self-retracting lifeline/fall limiter or rope grab and vertical lifeline with this device. All instructions and warnings provided with the body wear and connecting device must be read and understood before using the equipment.

Limits of Use

The Fusion Roof Anchor Post is designed to be used as a single anchorage point for a personal fall arrest system or as an intermediate anchorage post for approved Miller horizontal lifeline systems. Do not use the Fusion Post as an end or corner anchorage in a horizontal lifeline application unless approved by Miller Fall Protection.

The Fusion Roof Anchor Post is engineered for temporary or permanent installation and must always be installed in an upright position. Installation to wood sheathing is for temporary use only.

Capacity

Maximum capacity is one user at a maximum 310lbs (140.6kg), combined tool, clothing and body weight.

When used as a component within an approved Miller horizontal lifeline system, the system capacities apply. All instructions and warnings provided with the horizontal lifeline system must be read and understood before using the equipment.

Free Fall

Personal fall arrest systems must be rigged to limit a free fall to the shortest possible distance [6ft (1.8m) maximum].

In situations where free fall may exceed the 6ft (1.8m) maximum, a Miller lanyard with a MAX shock absorber pack must be used to keep fall arrest forces at or below 1800lbs (8kN). Free fall must never exceed 12ft (3.7m). All standards requirements for a free fall exceeding 6ft (1.8m) must be met. (See Approved Connecting Devices in 5.0 Connection to the Fusion Roof Anchor Post for other important considerations regarding free fall.)

Fall Arrest Forces

The Fusion Roof Anchor Post is uniquely engineered to absorb energy minimizing fall arrest forces imposed on the worker and the structure. The energy-absorbing, load distribution component within the Fusion Post activates at 1,000lbf (4.5kN).



Permissible Direction of Loading

In the event of a fall, the Fusion Roof Anchor Post orients in the direction of the force to provide 360° protection.

Fall Clearance

Ensure that adequate clearance exists in the potential fall path to avoid striking a lower level or other object. The potential for a swing fall must be minimized. Refer to 6.0 Fall Clearance in this manual and also to the instructions provided with the connecting device being used to calculate fall clearance distance. An extra 1ft (0.3m) of fall clearance must always be added into the calculation to account for the tip-over, energy-absorbing action of the roof anchor post. (See also Approved Connecting Devices in 5.0 Connection to the Fusion Roof Anchor Post for other important considerations regarding calculating fall clearance.)

Anchorage Requirements

The roof structure that the Fusion Roof Anchor Post is installed to must be capable of supporting a 5,000lb (22.2kN) static load in the direction of loading or meet OSHA requirements for a safety factor of two.

Anchorage requirements based on ANSI are as follows:

- For fall arrest systems, anchorages must withstand a static load of 5,000lbs (22.2kN) for non-certified anchorages or two times the maximum arresting force for certified anchorages.
- For positioning systems, anchorages must withstand a static load of 3,000lbs (13.3kN) for non-certified anchorages or two times the foreseeable force for certified anchorages.
- For travel restraint, anchorages must withstand a static load of 1,000lbs (4.5kN) for non-certified anchorages or two times the foreseeable force for certified anchorages.
- For rescue systems, anchorages must withstand a static load of 3,000lbs (13.3kN) for non-certified anchorages or five-times the applied load for certified anchorages.
- When more than one personal fall arrest system (PFAS) is attached to an anchorage, the above anchorage strengths must be multiplied by the number of PFASs attached to the anchorage.

The Fusion Roof Anchor Post is designed for either flat or low slope (less than 4:12 pitch) roof structures. This guideline makes the assumption that the roof can be safely traversed by workers without needing constant force against the connecting device to maintain footing or balance. The Fusion Roof Anchor Post may be used on a roof structure with greater than a 4:12 pitch providing proper footing is maintained. Typically, applicable standards and/or site requirements will require systems such as toe boards for properly working on steep slope roof surfaces.

The Fusion Roof Anchor Post, depending on model, is compatible with most industrial roof designs, including standing seam, membrane, built-up, metal sheathing, trapezoidal, concrete and wood. For additional requirements regarding specific roof types, refer to 3.0 Fusion Roof Anchor Post Diagrams and Descriptions and 4.0 Installation of Fusion Roof Anchor Posts. Fusion Roof Anchor Post models for steel decking, concrete and wood installations may also be installed on other Miller approved non-roof structures so long as all anchorage requirements are met. (Contact Miller Technical Services if there are additional questions regarding approved roof structures and applications.)

Environmental Hazards

Use of this equipment in areas where environmental hazards exist may require additional precautions to limit the possibility of injury to the user or damage to the equipment. Hazards may include, but are not limited to, extreme temperatures, caustic chemicals, corrosive environments, high voltage power lines, explosive or toxic gases, moving machinery, and sharp edges. Do not expose the equipment to any hazard which it is not designed to withstand. Consult the manufacturer in cases of doubt.

3.0 Fusion Roof Anchor Post Diagrams and Descriptions

Fusion Roof Anchor Post for Standing Seam Roofs

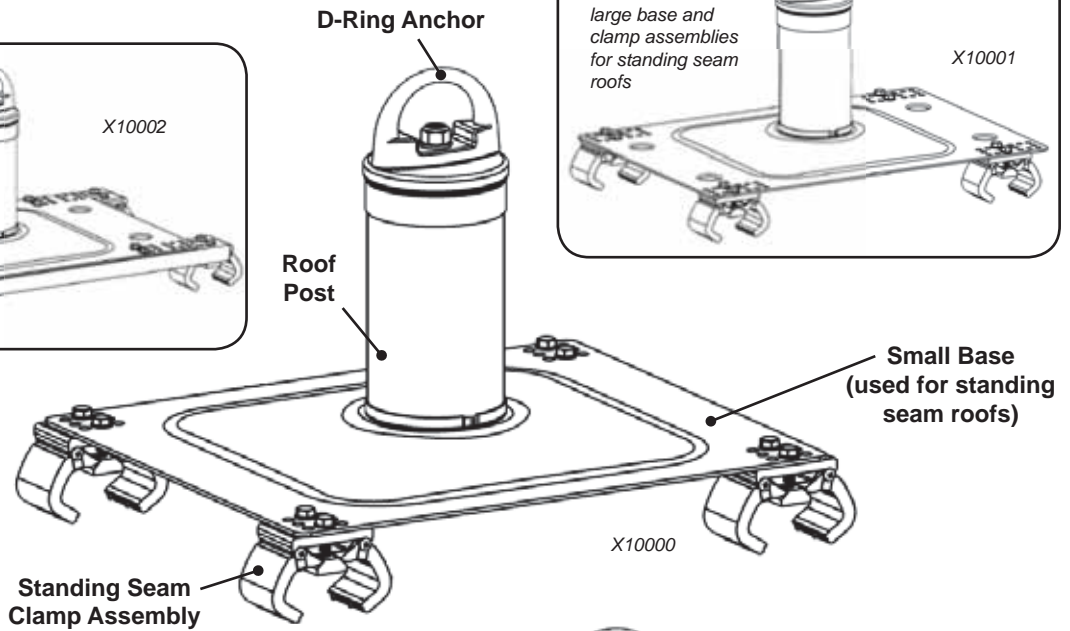
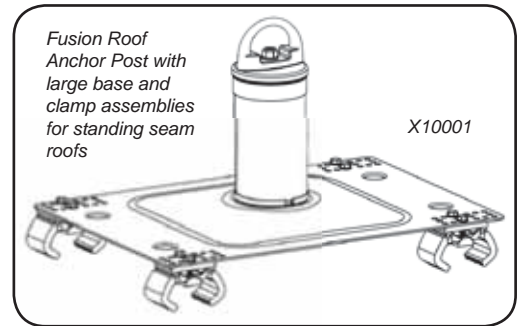
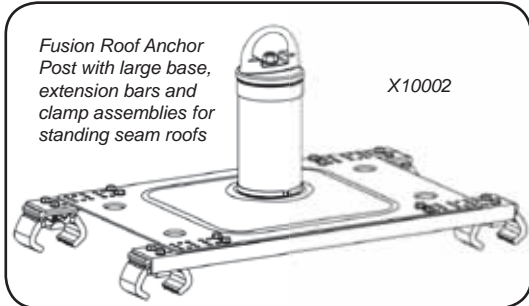

Fusion Roof Anchor Post for Metal Sheathing, Wood or Concrete Roofs

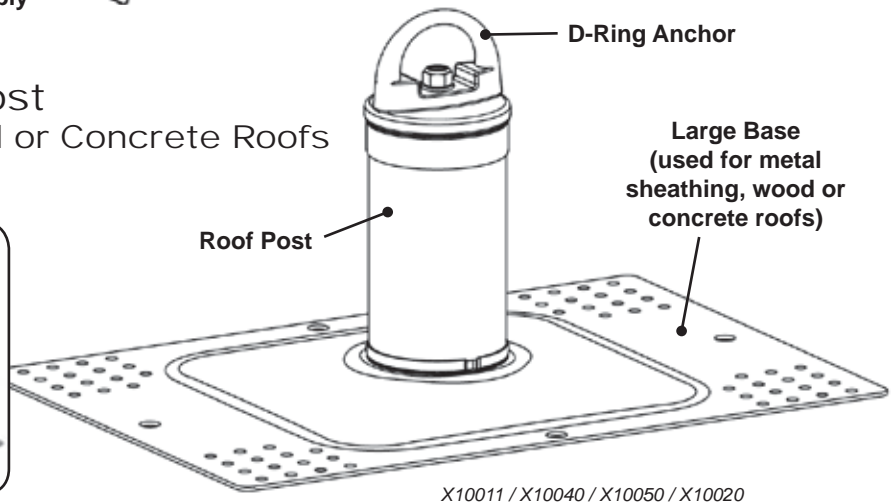
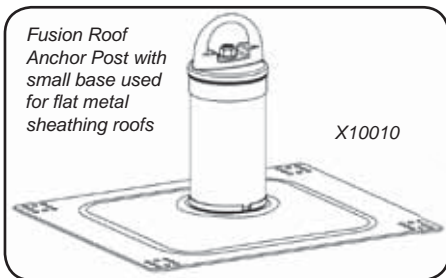

Fusion Roof Anchor Post for Membrane and Built-up Roofs

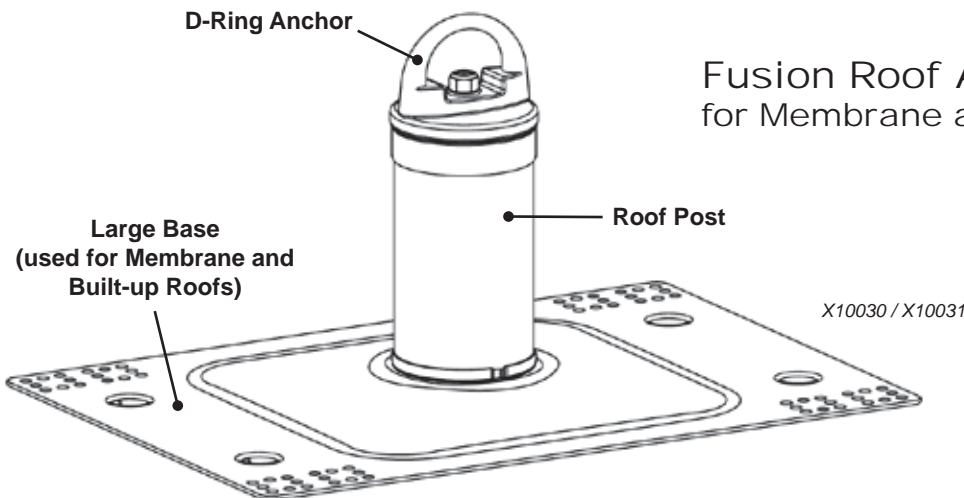

Part No.	Description	Attachment Method/ Hardware Included	Designed to Accommodate
Vector Fusion Roof Posts for Standing Seam Roofs			
X10000	Roof post with small base and D-ring anchor	4 clamp assembly kit	Standing seam spacing from 11.75 in. (298mm) to 17 in. (432mm)
X10001	Roof post with large base and D-ring anchor	4 clamp assembly kit	Standing seam spacing from 11.75 in. (298mm) to 21.25 in. (540mm)
X10002	Roof post with large base, extension bars and D-ring anchor	4 clamp assembly kit; 2 extension bars and bolts	Standing seam spacing from 11.75 in. (298mm) to 24 in. (610mm)
Vector Fusion Roof Posts for Metal Sheathing Roofs			
X10010	Roof post with small base and D-ring anchor	Rivet kit with sealing washers and mastic tape	Metal sheathing with minimum thickness of 24 gauge (0.024 in. [0.61mm])
X10011	Roof post with large base and D-ring anchor	Rivet kit with sealing washers and mastic tape	Metal sheathing with minimum thickness of 24 gauge (0.024 in. [0.61mm]); trapezoidal spacing of 8 in. (203mm) to 20 in. (508mm) in one-inch (25.4mm) increments
Vector Fusion Roof Posts for Membrane and Built-up Roofs			
X10030	Roof post with large base and D-ring anchor	5.5 in. toggle bolt kit	Fastens through membrane, insulation and into metal sheathing, wood sheathing or concrete with a combined thickness of up to 5.5 in. (140mm)
X10031	Roof post with large base and D-ring anchor	10.5 in. toggle bolt kit	Fastens through membrane, insulation and into metal sheathing, wood sheathing or concrete with a combined thickness between 5.5 in. (140mm) and 10.5 in. (267mm)
Vector Fusion Roof Post for Wood Sheathing Roofs (Temporary installations only)			
X10040	Roof post with large base and D-ring anchorage connector	Lag screw kit	Plywood with a minimum thickness of 5/8-in. (15.9mm) CDX
Vector Fusion Roof Post for Concrete Roofs			
X10050	Roof post with large base and D-ring anchorage connector	Concrete expansion bolt anchor kit	Concrete decking with minimum thickness of 6.5 in. (165mm) and minimum concrete compressive strength of 3000 PSI (20.7 MPa)
Vector Fusion Roof Post for Metal Decking, Wood or Concrete Roofs			
X10020	Roof post with large base and D-ring anchorage connector	Hardware not included	With Miller approved hardware, accommodates same as X10011, X10040 and X10050, depending on application.

Dimensions

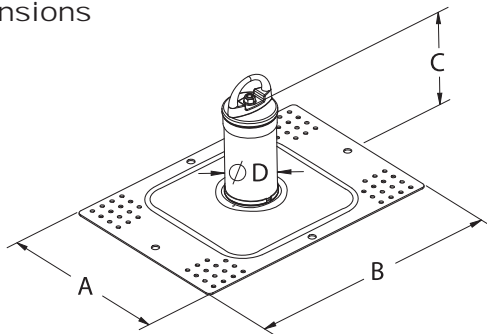

Part No.	Width A	Length B	Height C	Post Dia. D	
X10000 X10010	15.25in (387mm)	18in (457mm)	8.6in (218mm)	4in (102mm)	
X10001 X10011 X10020 X10040 X10050		22in (559mm)			
X10030 X10031		9in (229mm)			
X10002		15.6in (396mm)	26in (660mm)		9.56in (243mm)

Specifications

Roof Anchor Post Materials

Energy Absorber:	Stainless Steel
Internal Connecting Components:	Stainless Steel
Top and Bottom Post Plates:	Anodized Cast Aluminum
Standing Seam/Wood/Metal Base Plate:	Two-layer Zinc/Powder-Coated Steel
Post/Base Plate Seal:	HDPE
Post Cap:	Vinyl w/UV Inhibitor
D-Ring Anchor:	Zinc Chromate Steel

Connection Component Materials

Standing Seam Clamps:	Anodized Aluminum/ Stainless Steel
Extension Bars:	Stainless Steel
Hardware for Metal Sheathing:	Hot Dip Galvanized/Neoprene
Hardware for Membrane:	Zinc-Plated Steel/PVC/Neoprene
Hardware for Wood:	Zinc-Plated Steel
Hardware for Concrete:	Stainless Steel

4.0 Installation of Fusion Roof Anchor Posts

- Before installation, carefully inspect all components of the system according to the manufacturer's instructions (see 8.0 Inspection and Maintenance).
- Some system components may come preassembled. Installation instructions still must be followed to ensure all components are included and properly assembled. All fasteners and connectors must be checked for correct alignment and installation and tightened to required specifications.
- Hardware provided with product at the time of shipment must be used for proper installation. For installation of Model X10020, Miller approved hardware must be used depending on the application. Do not use alternate hardware/parts unless approved by Miller Fall Protection. All installation instructions must be followed, including any installation instructions provided with the hardware. Contact Miller Technical Services if there are any discrepancies.
- Contact Miller Technical Services at 800.873.5242 if there are any questions about the installation requirements and/or procedures.

4.1 Roof Anchor Post Assembly

Post to Base Assembly

1. Set gasket on base aligning the center holes as shown in Fig. 1a.
2. Insert the bolt extruding from the bottom of the post through the gasket and base.
3. Tighten until snug against gasket and base.

D-Bolt Anchor to Post Assembly

1. Place D-bolt anchor over bolt extruding from the top of the post as shown in Fig. 1a.
2. Attach washer and nut.
3. Torque to approximately 20ft.lbs. (20.1Nm).

Fig. 1a

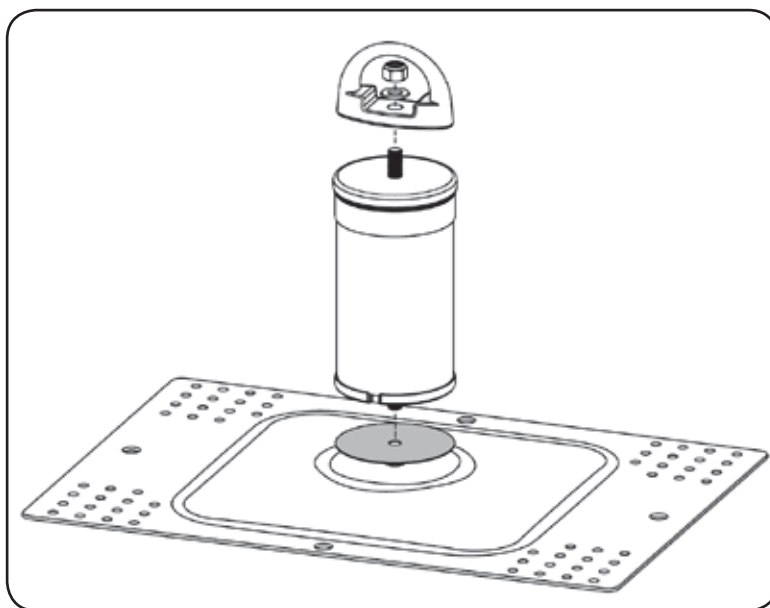
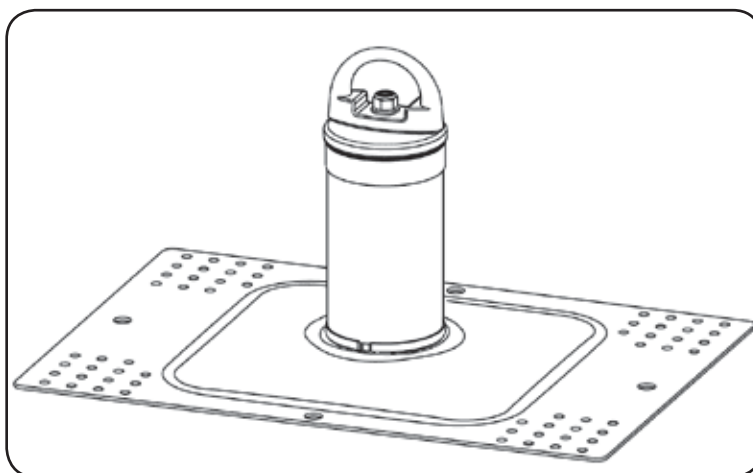

Fig. 1b -
Completely
Assembled



4.2 Base Installation

- Always follow a previously approved site plan and site work rules when installing a Fusion Roof Anchor Post.
- The roof structure to which the Fusion Roof Anchor Post is being installed must be capable of sustaining the load requirements as set forth in 2.2 System Warnings and Limitations.
- When determining distance from roof edge to install the roof anchor post, it must be verified that the roof structure at the point of installation is able to sustain the potential fall arrest loads. As a general rule, it is recommended that the roof anchor post be installed at least 3ft (0.91m) from the roof edge.
- Proper precautions must be taken to ensure that the installer is not exposed to a fall hazard during the installation process.
- Always install the Fusion Post in the upright position to ensure proper operation.

4.2.1 Installation of Base to Standing Seam Roofs (Models X10000, X10001 and X10002)

Standing seam spacing of roof must be determined before attaching clamp assemblies to small or large standing seam base. Refer to the Small and Large Base Spacing Diagrams (Fig. 2a and 2b) for help in determining the rows needed to create the spacing required for the standing seam roof. Remember that the clamp assemblies are designed to self-center allowing spacing to be off-set slightly. Clamp assemblies may be installed to any two of the corner 0.34in (8.64mm) diameter mounting holes in a row at each of the four corner locations to accommodate the maximum number of standing seam roofs with various spacing requirements. Optional extension bars may be used for additional spacing needs.

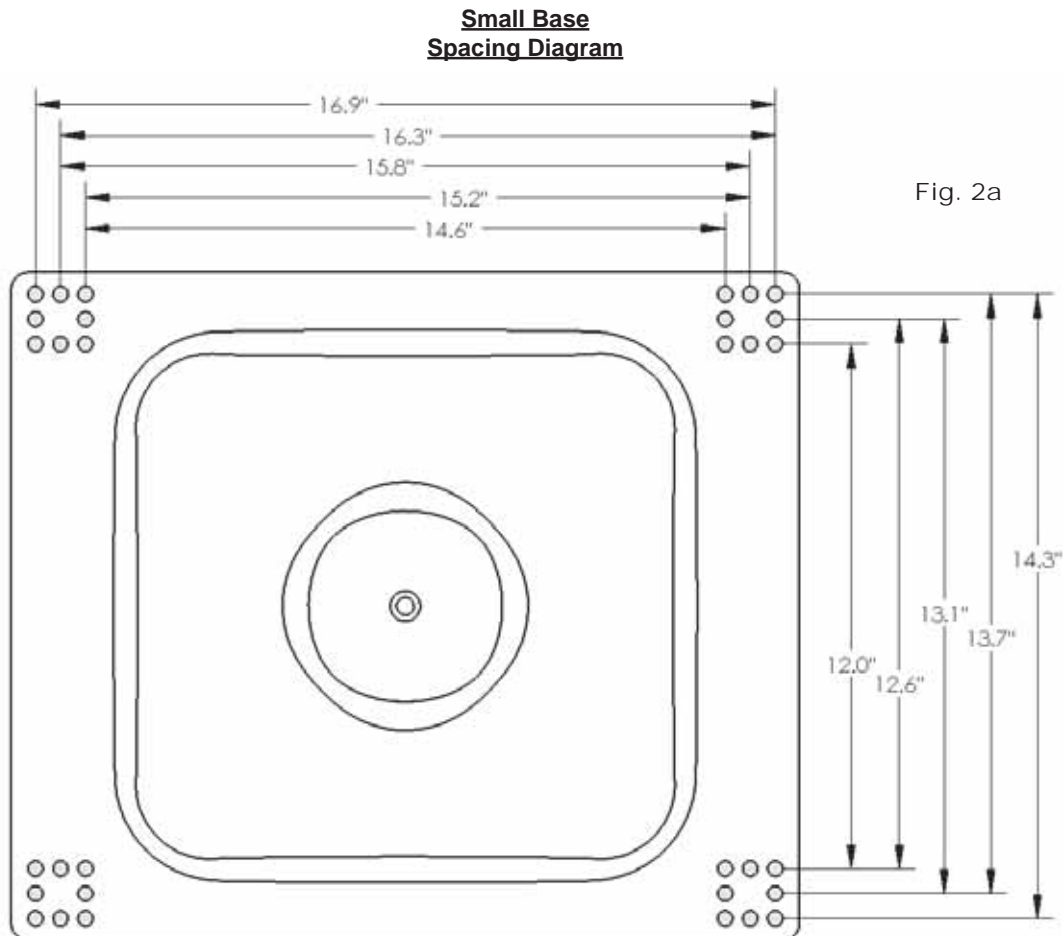

Fig. 2a

Large Base Spacing Diagram

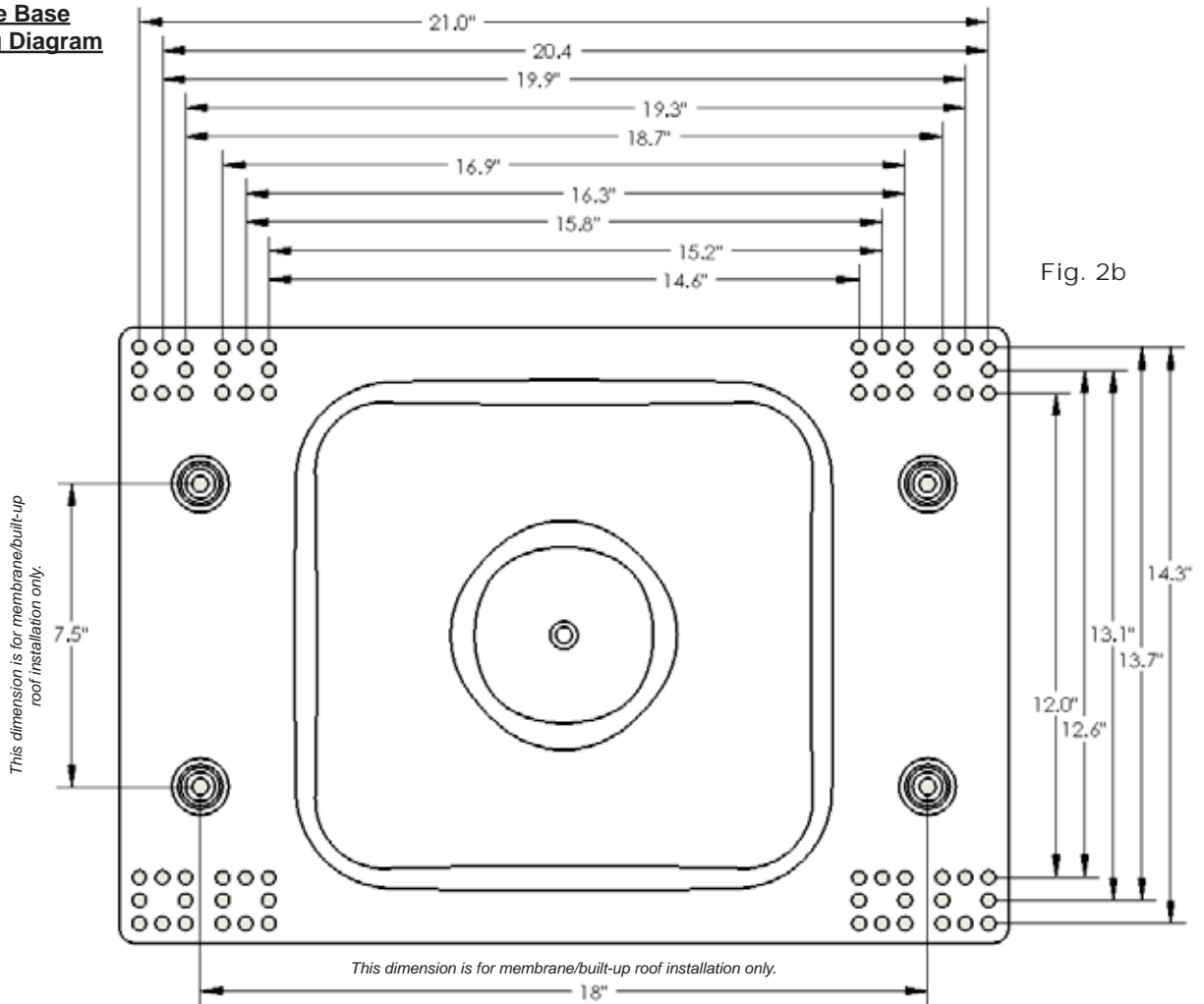
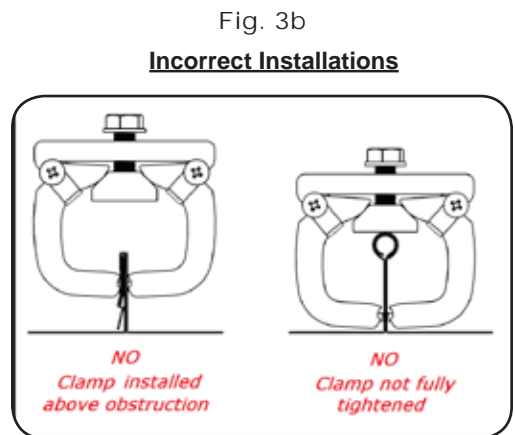
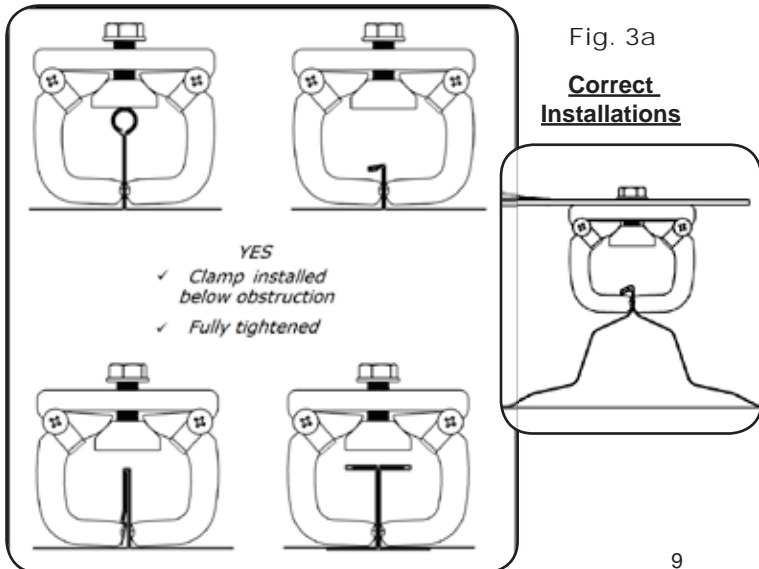

Fig. 2b

Due to the large number of standing seam roof styles, the following illustrations are provided to set guidelines for establishing a correct and secure installation. As a general rule, the clamp assemblies should always be installed to the standing seam as far down as possible below an obstruction (the seam must not be narrower above where the clamp is closed on the seam). Do not install to sloped portions of a standing seam as the clamp may have the potential to slip. If in doubt about proper installation to a particular standing seam roof style, contact Miller Technical Services.



Installation of Small Base - Model X10000

1. Once standing seam spacing has been determined, attach one clamp assembly to each of the four corners of the base as shown in Fig. 4a. Install each bolt completely through the washer and base mounting hole and into the corresponding hole in the clamp assembly bar. Do not tighten until the base is set on the standing seam roof.
2. Place base with open clamp assemblies over the standing seams and proceed with closing and tightening clamp assemblies. Clamp assemblies are designed to self-center for proper alignment. Standing seam roofs differ, but in all cases the clamps must close below the seam obstruction to ensure that they are properly secured and will not slip (see Fig. 3a). Torque clamp assemblies to 20ft.lbs., alternating bolts until all bolts have achieved the correct torque value. *Note: Once the first bolt has reached 20ft. lbs., do not tighten the other three bolts more than three times each.*

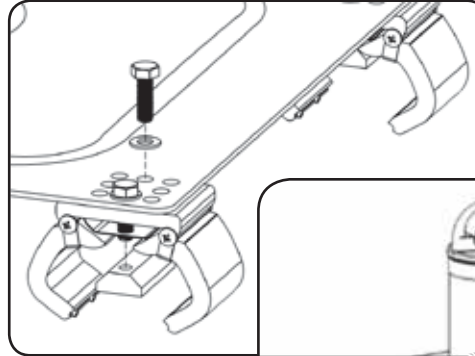

Fig. 4a

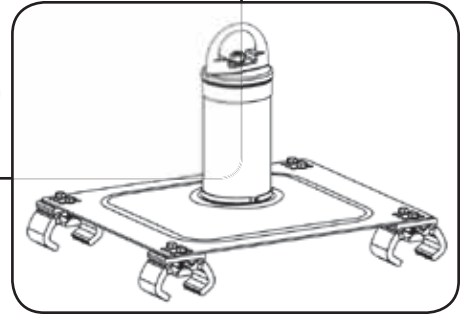
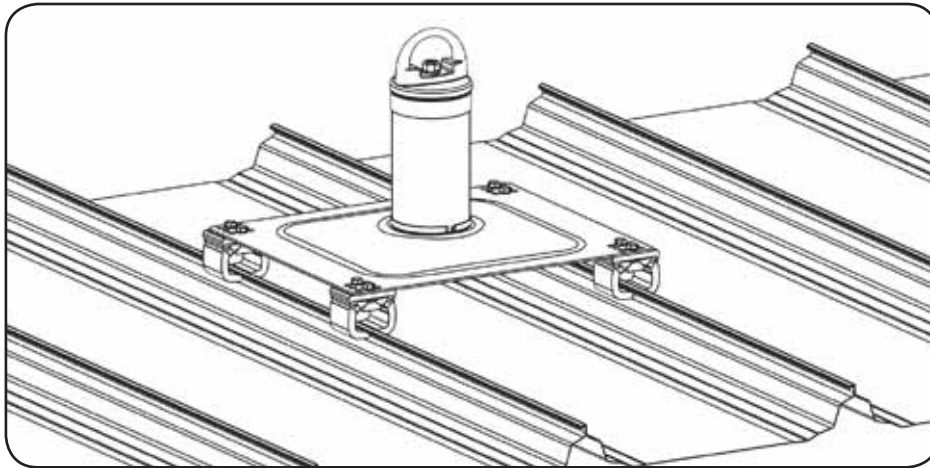

Fig. 4b

Fig. 4c - Completely Installed



Installation of Large Base - Model X10001

1. Once standing seam spacing has been determined, attach one clamp assembly to each of the four corners of the base as shown in Fig. 5a. Install each bolt completely through the washer and base mounting hole and into the corresponding hole in the clamp assembly bar. Do not tighten until the base is set on the standing seam roof.
2. Place base with open clamp assemblies over the standing seams and proceed with closing and tightening clamp assemblies. Clamp assemblies are designed to self-center for proper alignment. Standing seam roofs differ, but in all cases the clamps must close below the seam obstruction to ensure that they are properly secured and will not slip (see Fig. 3a). Torque clamp assemblies to 20ft.lbs., alternating bolts until all bolts have achieved the correct torque value. *Note: Once the first bolt has reached 20ft.lbs., do not tighten the other three bolts more than three times each.*

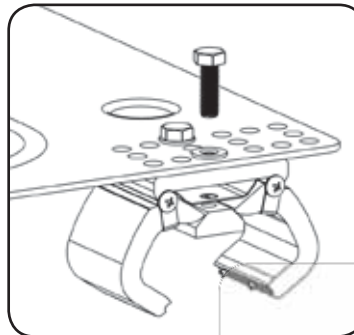

Fig. 5a

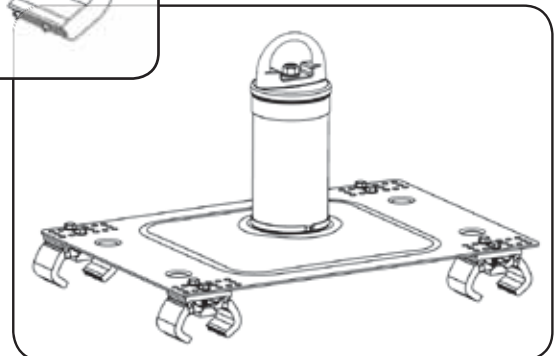
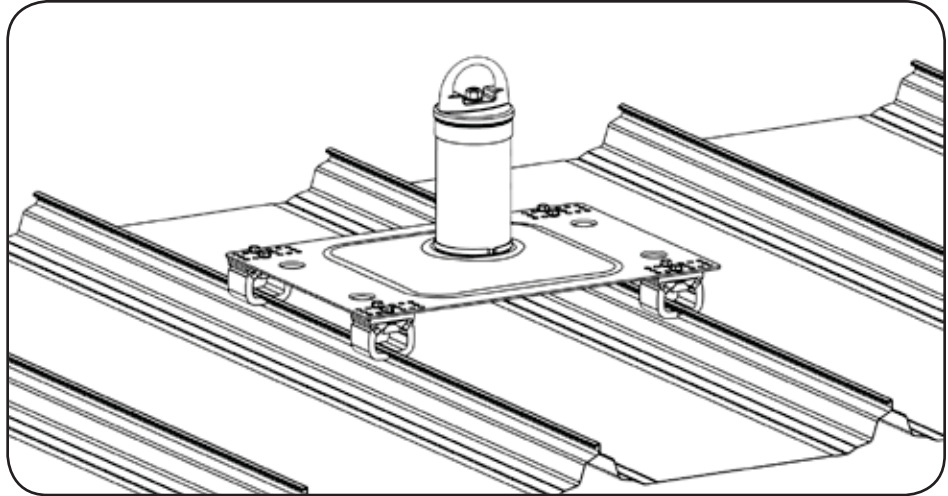

Fig. 5b

Fig. 5c - Completely Installed



Using Extension Bars - Model X1002

For standing seam roofs with spacing greater than 21.25in (540mm) and up to 24in (610mm), extension bars may be added to the base.

1. Place extension bar on the underside of base, aligning holes in base with those on the extension bar.
2. Attach hardware as shown in Fig. 6a. Insert each bolt through washer, base and extension bar and attach washer and nut on the underside. Two bolts must be used on each end of the extension bar (for a total of four bolts) for proper installation.
3. Repeat procedure for extension bar on opposite side of base. Torque extension bar hardware to 20ft.lbs.
4. Once standing seam spacing has been determined, attach one clamp assembly to each extension bar end as shown in Fig. 6b. Install each bolt completely through the washer and extension bar mounting hole and into the corresponding hole in the clamp assembly bar. Do not tighten until the base is set on the standing seam roof.
5. Place base with open clamp assemblies over the standing seams and proceed with closing and tightening clamp assemblies. Clamp assemblies are designed to self-center for proper alignment. Standing seam roofs differ, but in all cases the clamps must close below the seam obstruction to ensure that they are properly secured and will not slip (see Fig. 3a). Torque clamp assemblies to 20ft. lbs., alternating bolts until all bolts have achieved the correct torque value. *Note: Once the first bolt has reached 20ft.lbs., do not tighten the other three bolts more than three times each.*

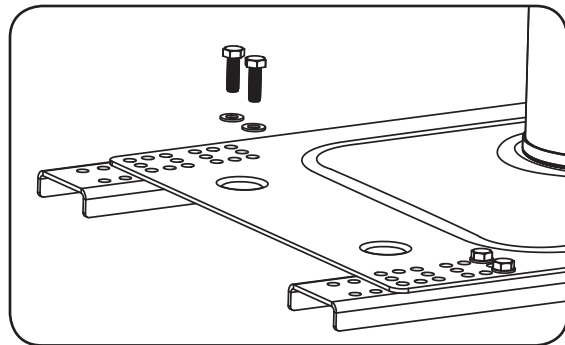

Fig. 6a

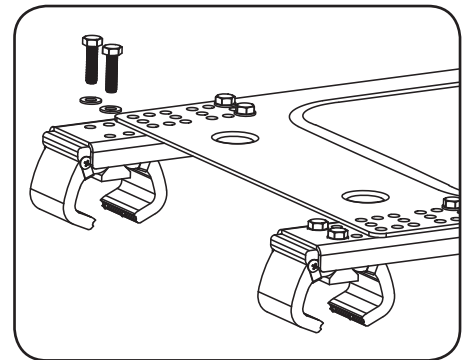
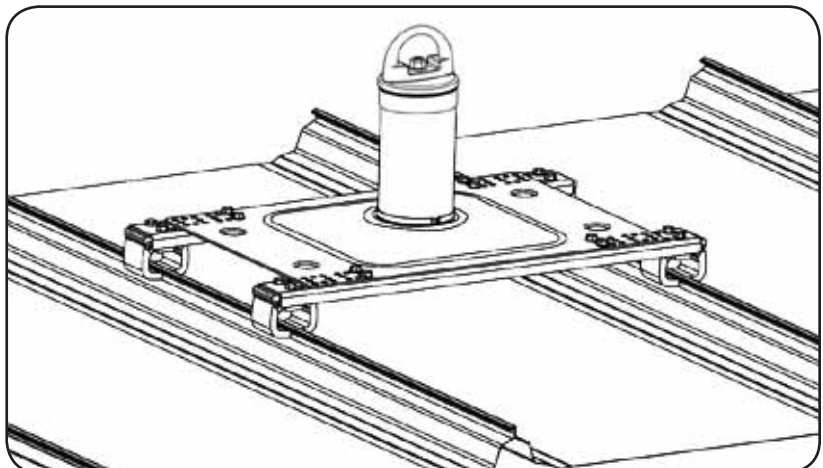

Fig. 6b

Fig. 6c - Completely Installed



4.2.2 Installation of Base to Metal Sheathing (Models X10010 and X10011)

Model X10010 (small base) is designed for installation to flat metal sheathing only. Model X10011 (large base) anchors to flat metal sheathing as well as trapazoid profile/ribbed metal roofs.

Small Base - Model X10010

1. Position the base on metal decking as shown in Fig. 7a.
2. With the base in position, drill four 0.257in (6.53mm) to 0.261in (6.63mm) diameter pilot holes in a square pattern through the metal decking at each of the corner mounting locations for a total of 16 holes.
3. Remove the base and place a length of mastic tape over each set of pilot holes.
4. Reposition the base on the metal decking aligning the pilot holes with the mounting holes on the base plate. Install each of 16 rivets through a sealing washer and the corresponding base mounting hole and into the mastic tape and pilot holes in the metal decking using an appropriate riveting tool.

WARNING: All sixteen (16) rivets with sealing washers must be used to secure the base properly.

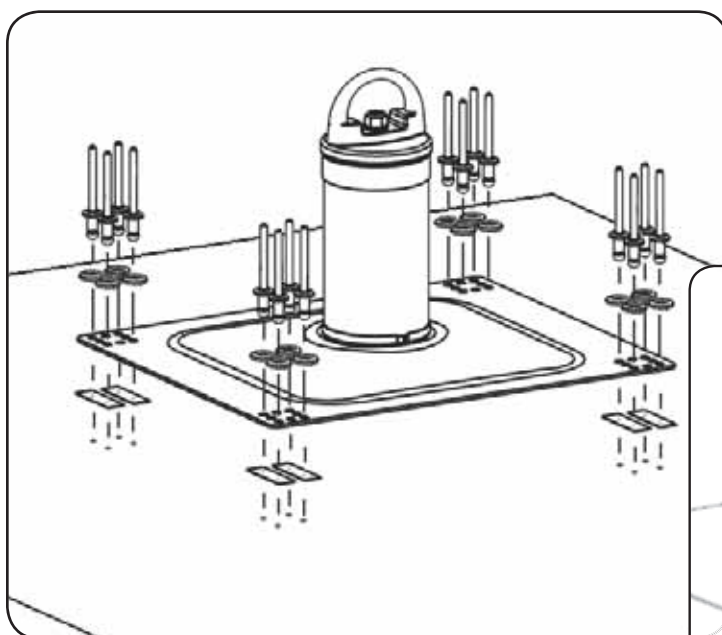

Fig. 7a

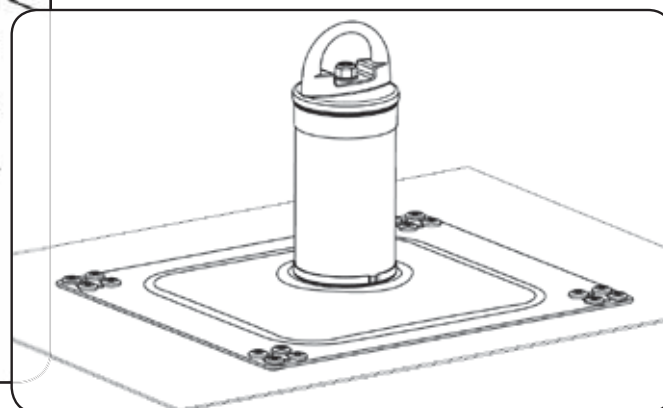

Fig. 7b - Completely Installed

Large Base - Model X10011

1. Position the base on metal decking such that a row of 0.34in (8.64mm) diameter mounting holes aligns with decking ribs at each of the four base plate corners as shown in Fig. 8b. Refer to spacing diagram (Fig. 8a) if needed. Mounting holes must be centered on decking rib crowns. Never align mounting holes over the rib valleys or on the sloped sides of the decking ribs.
2. With the base in position, drill four 0.257in (6.53mm) to 0.261in (6.63mm) diameter pilot holes in a row through the decking ribs at each of the corner mounting locations for a total of 16 holes.
3. Remove the base and place a length of mastic tape over each set of pilot holes.
4. Reposition the base on the metal decking aligning the pilot holes with the mounting holes on the base plate. Install each of 16 rivets through a sealing washer and the corresponding base mounting hole and into the mastic tape and pilot holes in the decking ribs using an appropriate riveting tool.

WARNING: All sixteen (16) rivets with sealing washers must be used to secure the base properly.

Fig. 8a

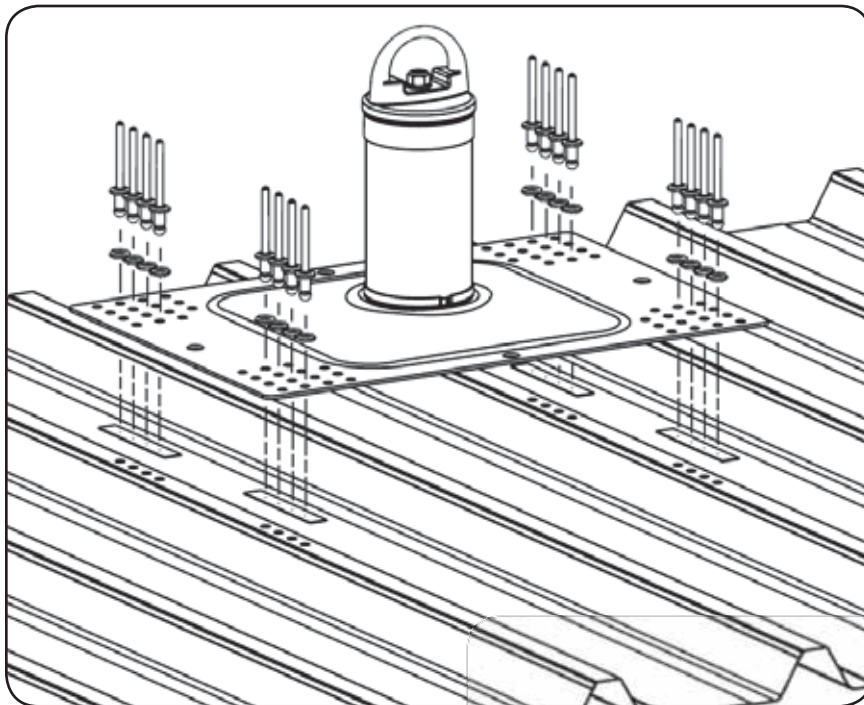
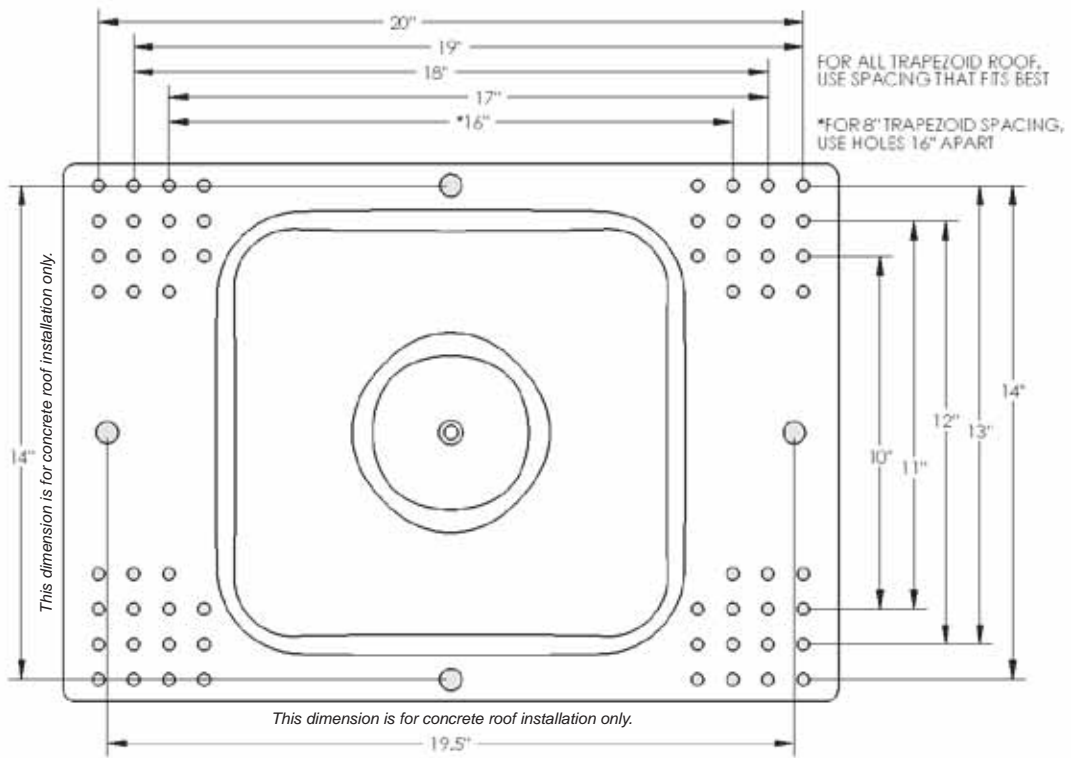
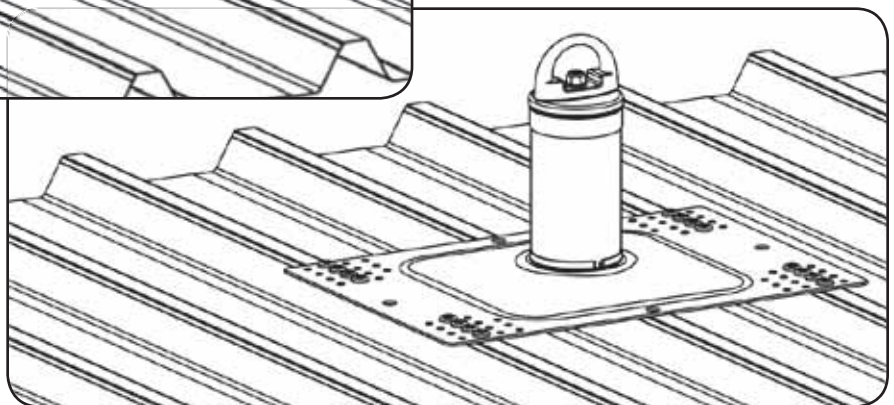

Fig. 8b

Fig. 8c -
Completely Installed



4.2.3 Installation of Base to Membrane and Built-up Roofs (Models X10030 and X10031)

Fusion Roof Anchor Models X10030 and X10031 are designed for installation to flat membrane covered or built-up roofs. Model X10030 includes a toggle bolt kit for membrane/built-up roofs with a combined thickness of up to 5.5in (140mm), while Model X10031 includes a toggle bolt kit for combined roof thicknesses between 5.5in (140mm) and 10.5in (267mm).

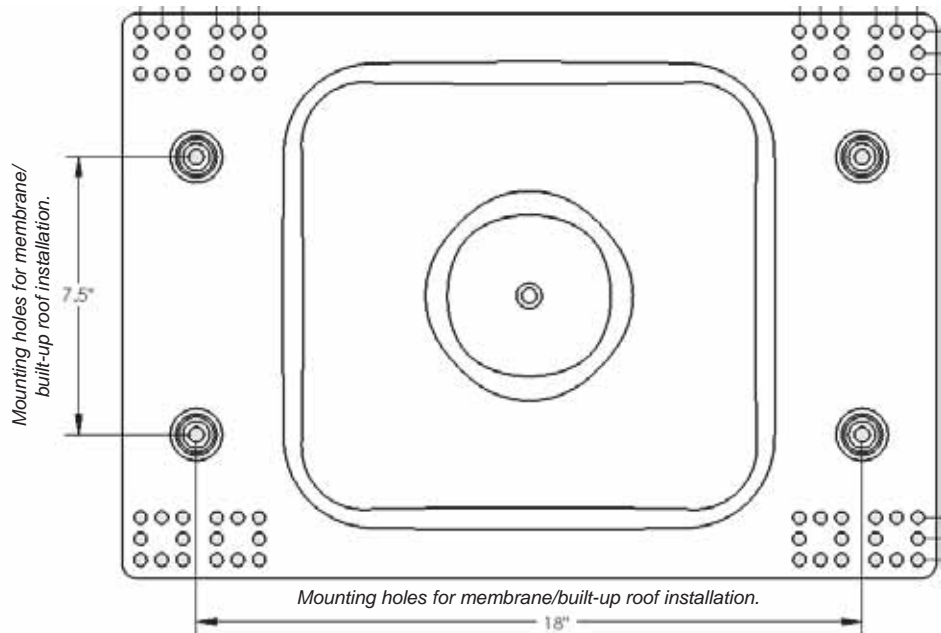

1. Position the base at the desired location on the roof.
Note: All four mounting holes must be located over the roof decking. Be careful that mounting holes are not located directly over a structural roof support or beam that may interfere with toggle installation. Refer to the spacing diagram (Fig. 9a) if needed. When ribbed metal decking is a component in the membrane or built-up roof, the toggle bolts must be located either on the flat crown surface or the flat valley surface, but must not be located on the sloped rib surface.

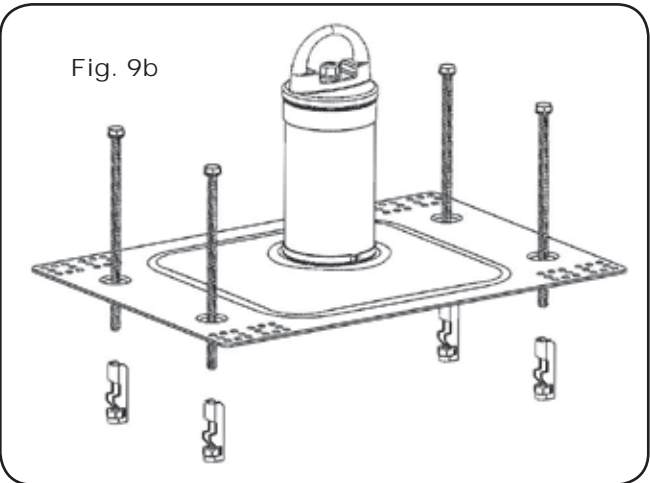

2. With the base in position, use the base as a template to mark the four mounting hole locations.
3. Remove base and drill test holes with a long 1/4in (6.35mm) drill bit to ensure proper placement of the toggle bolts to ribbed decking. The drill will deflect if a sloped rib surface is hit; in which case, the base must be repositioned, mounting holes remarked and new test holes drilled until an approved installation location is found.

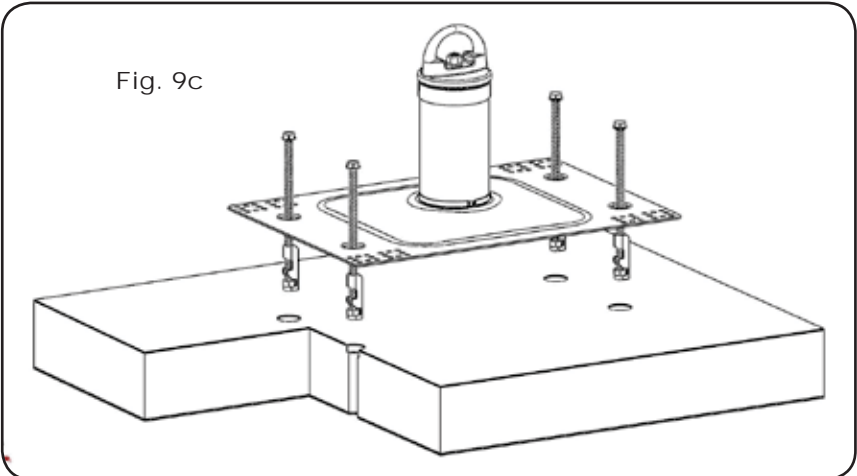

4. Once test holes are successfully drilled, set the base aside and drill four 1.25in (31.75mm) diameter holes through the membrane and into the insulation 1in (25.4mm) deep. This hole acts as a counter bore to properly seat the roof anchor.
5. Then drill four 1in (25.4mm) diameter holes in the center of each previously drilled counter bore hole through the insulation and into the roof decking.
6. Assemble toggle and nut together and place below base plate (see Fig. 9b). Insert bolt through plate and thread into nut until fully engaged (see Fig. 9c). Do not leave more than one thread exposed beyond nut as that will interfere with the toggle function. Do the same for the other three toggles.

7. After toggle/nut/bolt are assembled to plate, place over predrilled holes and insert into roof (see Fig. 9d).
8. Shake toggle several times to flip into horizontal position (see Fig. 9e). Check by lifting toggle bolt assembly to make sure toggle is flipped and does not come up through holes.
9. Place magnet into 17mm socket (see Fig. 9f). Place socket over bolt and use drill/driver to lift toggle until contact is made with the bottom of the roof (see Fig. 9g).
10. Apply upward force to keep toggle stationary while tightening toggle bolt with drill/driver.

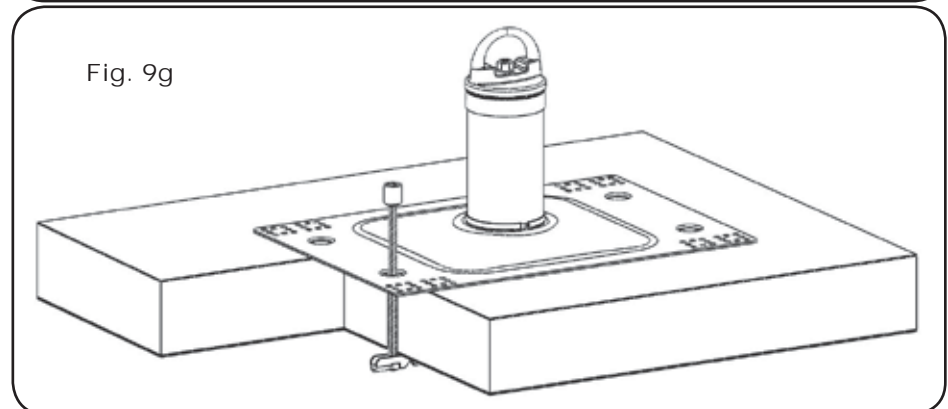
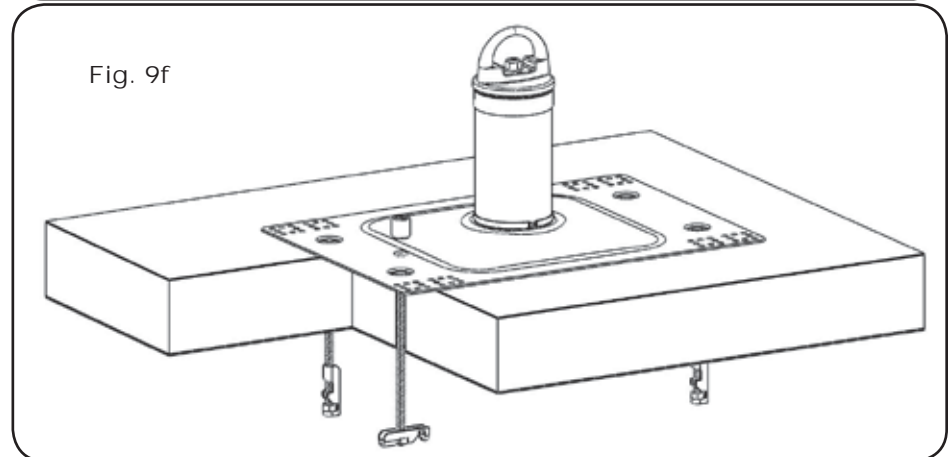
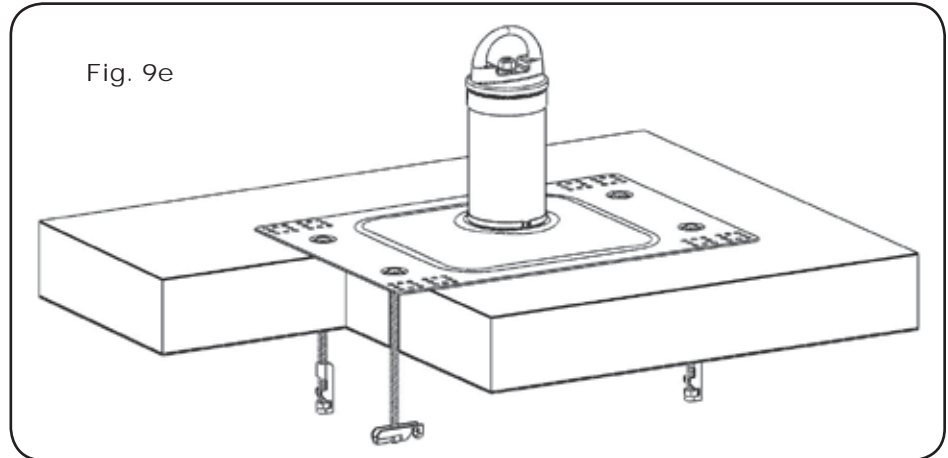
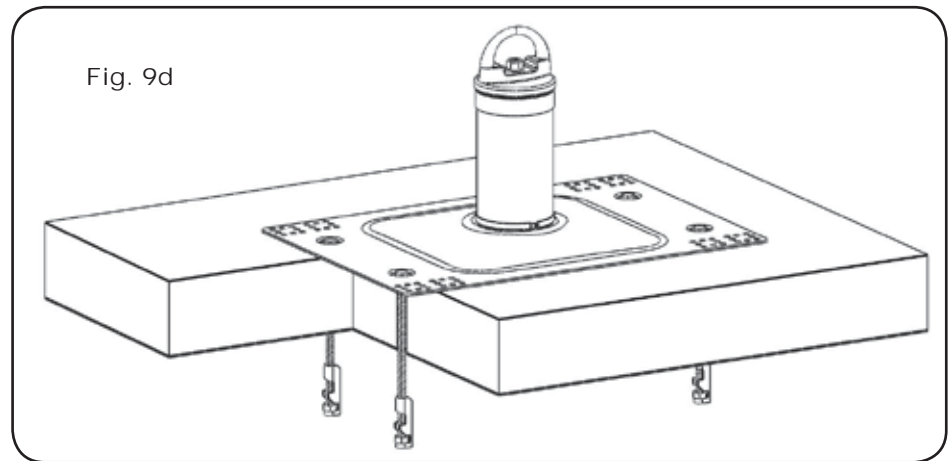

11. Once toggle is fully drawn up and seated (see Fig. 9h and 9i), torque to approximately 10-15 ft lbs. Repeat for other three toggle bolt assemblies.
12. Apply sealant around each bolt head. Fill entire open area in the counter bore of each of the four holes. Over filling is advised as it will protect against wear of the bolt into the membrane due to foot traffic.
13. Place membrane gasket around base plate and seal all edges with roof sealant.

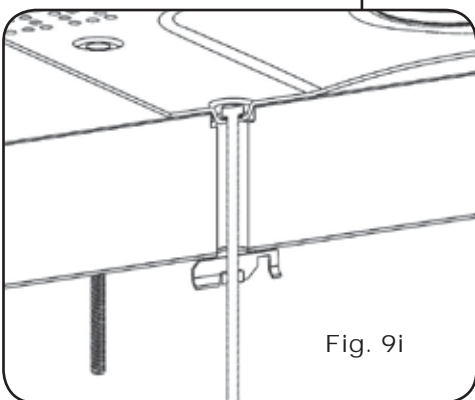
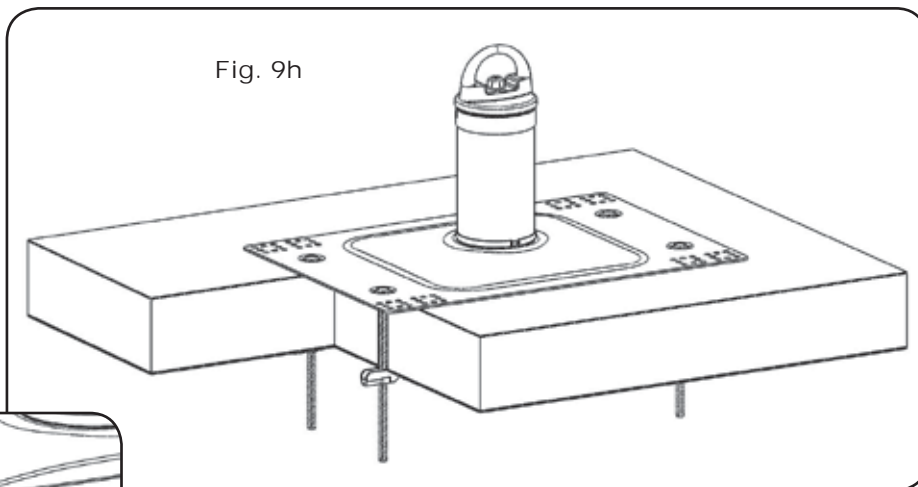

Note: A roofing contractor approved for servicing the membrane should be used to properly weatherproof the roof anchor post once installed.

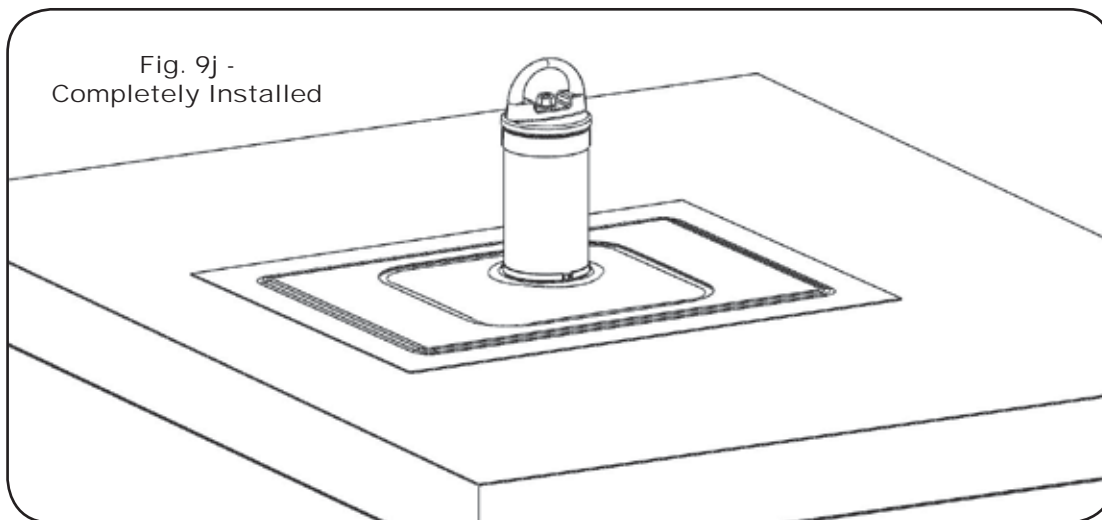

4.2.4 Installation of Base to Wood Sheathing Roofs (Model X10040)

Fusion Roof Anchor Model X10040 is designed to be installed directly to the plywood roof decking and is for temporary use only. For installations where roof membrane, insulation, or other roofing materials cover the plywood decking, use Miller Fusion Roof Anchor Model X10030 or X10031.

1. Position the base at the desired location on the roof.

Note: All mounting holes must be located over the roof decking. Be careful that mounting holes are not located directly over a structural roof support or beam with a thickness and/or material that may interfere with lag screw installation.

2. With the base in position, drill four 1/4in (6.35mm) diameter pilot holes through the plywood decking at each of the corner mounting locations for a total of 16 holes (see Fig. 10a). Any four mounting holes may be used for installation so long as they are not adjacent to one another.
3. Install each of 16 lag screws through the base mounting hole and into the corresponding pilot hole in the plywood decking. Tighten lag screws until snug and properly seated.

WARNING: All sixteen (16) lag screws must be used to secure the base properly. Do not over-tighten lag screws as damage may occur to the plywood decking resulting in insufficient strength to support potential fall arrest forces.

Fig. 10a

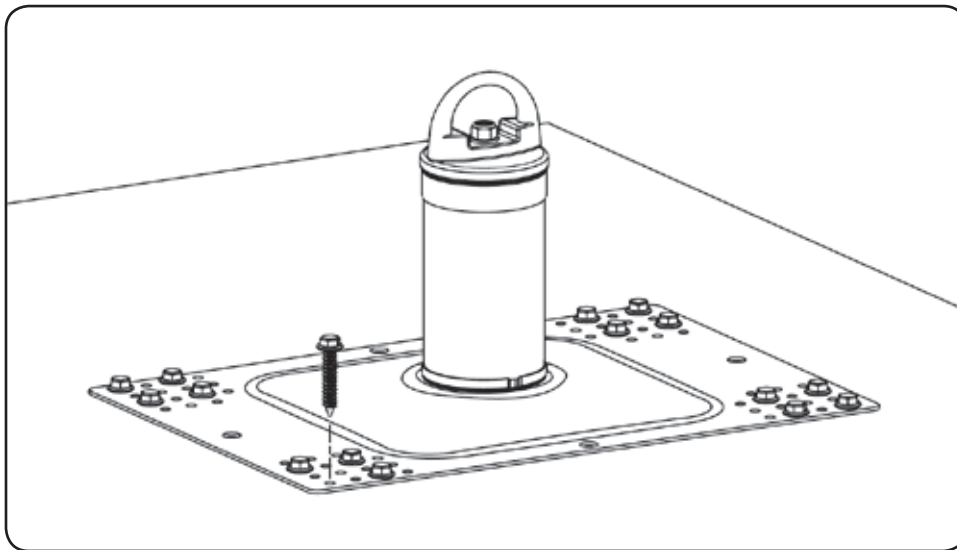
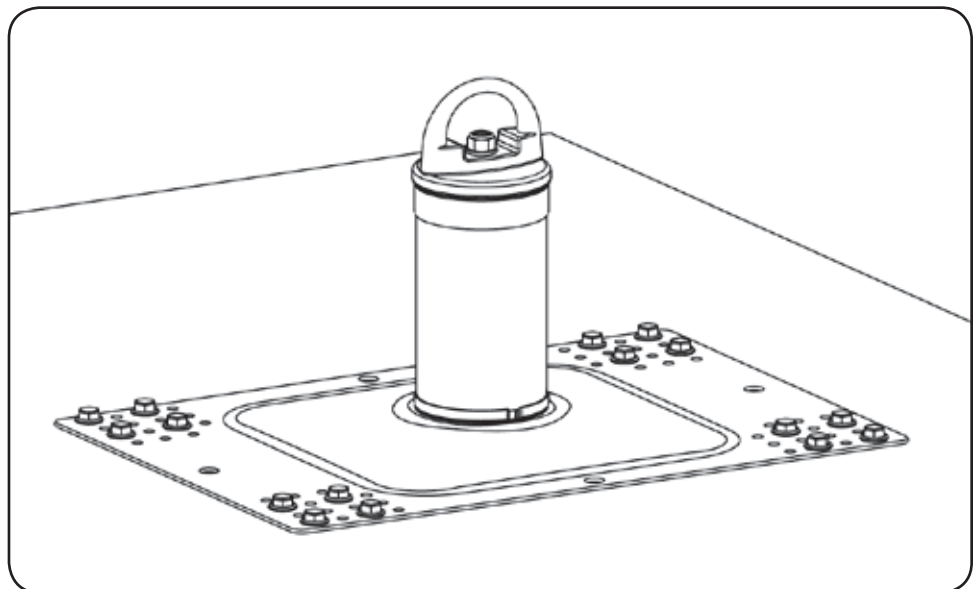

Fig. 10b -
Completely Installed



4.2.5 Installation of Base to Concrete Roofs (Model X10050)

Fusion Roof Anchor Model X10050 is designed for concrete roof installation. Concrete must have a minimum compressive strength of 3000 PSI and minimum thickness of 6.5in (165mm).

Fig. 11a

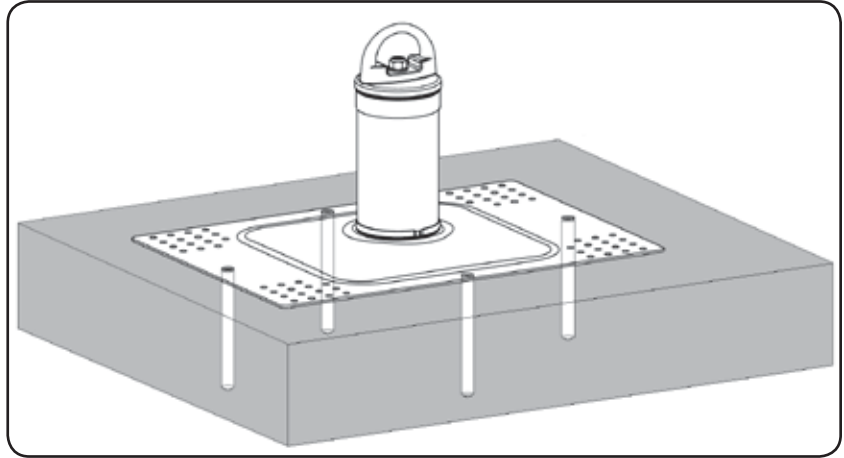

1. Position the base at the desired location on the roof.
2. With the base in position, use the base as a template to mark the four mounting hole locations as shown in Fig. 11a.
3. Remove base and drill a 1/2in (12.7mm) hole to a depth of 4-3/4in (120.65mm) at each of the four mounting locations.
4. Clean all debris from each hole using a blow out bulb.
5. Reposition the base on the roof aligning the mounting holes over the drilled holes.
6. Then drive an expansion bolt through the base mounting hole and into the corresponding drilled hole at each of the four mounting locations (see Fig. 11b).
7. Make sure the underside of the expansion bolt head is flush with the base plate before tightening. Torque each bolt to between 50-60ft.lbs. using a 3/4in socket wrench.

WARNING: All four (4) expansion bolt anchors must be used to secure the base properly.

Fig. 11b

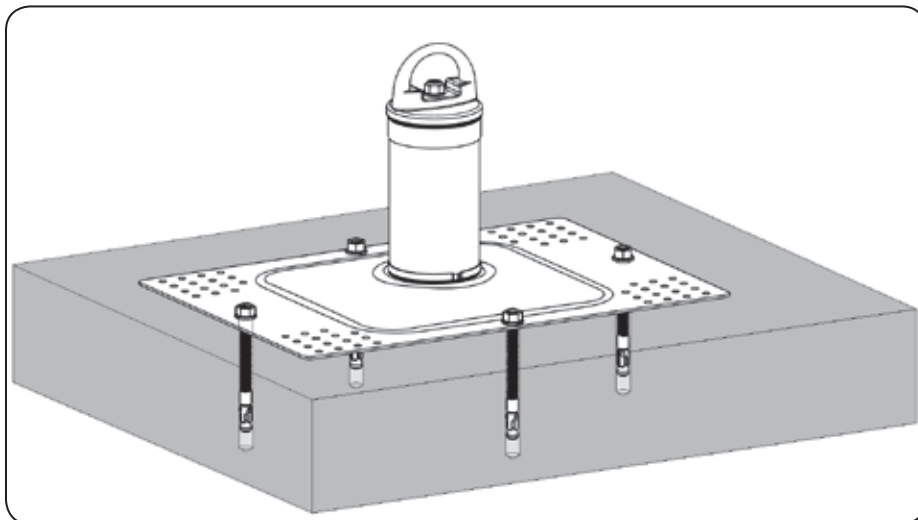
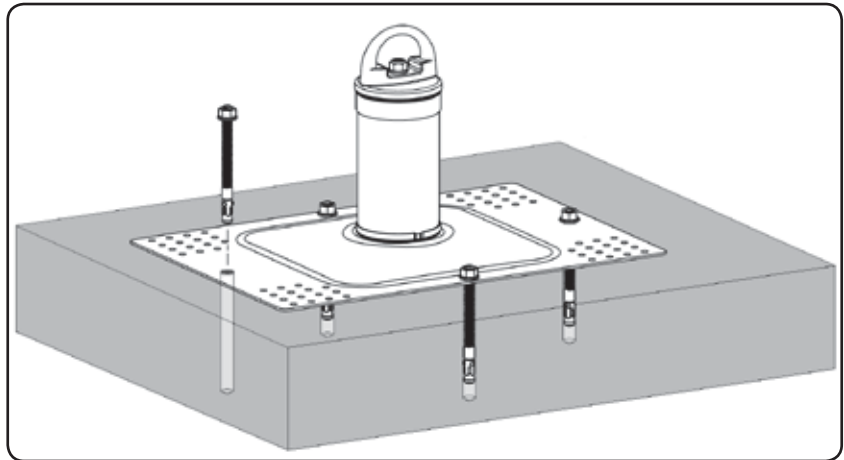

Fig. 11c - Completely Installed

4.2.6 Installation of Base w/o Included Hardware (Model X10020)

Fusion Roof Anchor Model X10020 is designed to be installed to metal decking, wood or concrete roofs with alternative Miller approved hardware. The hardware is not included; therefore, the following graphs and drawings must be referenced to ensure that the hardware selected meets the strength requirements for the anchor application.

Notes:

- Roof anchorage strength must be known. OSHA requires 5000lbf (22.2kN) or 2:1 safety factor in the permissible direction of loading. [For a personal fall arrest system (PFAS) with a maximum fall arrest force of 900lbf (4kN), the anchorage strength must be 1800lbf (8kN) to maintain a safety factor of two; for a PFAS with a maximum fall arrest force of 1800lbf (8kN), the anchorage strength must be 3600lbf (16kN).]
- Shear and tensile strength requirements are per each corner of the base plate (or each side as is the case when the expansion bolt anchor mounting holes are used in concrete installation.) Figure 12a shows the shear strength required for the fasteners corresponding to the anchorage strength requirement. Figure 12b shows the tensile strength required for the fasteners corresponding to the anchorage strength requirement. Both Figures 12a and 12b must be used in selecting appropriate fasteners to ensure safe and secure installation of the Fusion Roof Anchor Post.
- For greater understanding, Figures 12c, 12d and 12e demonstrate how the roof anchor post reacts when exposed to fall forces. These figures are for reference only and should not be used to determine Hardware Strength Requirements.
- If there are any questions in regard to approved hardware and/or the following graphs and drawings, Miller Technical Service must be consulted before proceeding with installation of the Fusion Roof Anchor Model X10020.

Fig. 12a

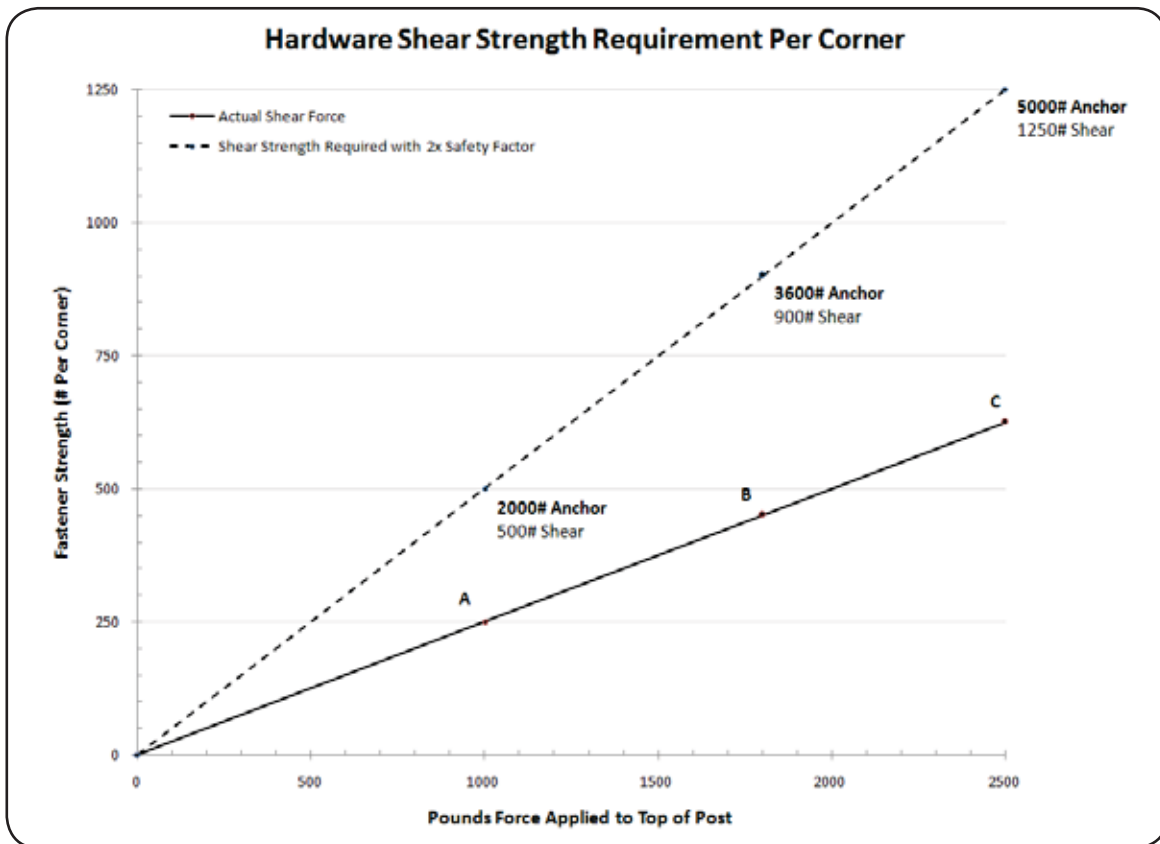

Calculations:

Shear Strength Requirement = 1/4 of LBF Load Applied to Top of Anchor Post
 Points A, B and C represent forces applied to the post and the resulting shear forces applied to each corner through the base fasteners. Fastener strength requirements are based on a 2:1 safety factor and are represented by the dashed line. The minimum fastener shear strength per corner is 500lbf (2.22kN); however, when potential post forces exceed 1000lbf (4.45kN), the fasteners must be designed to the shear requirements shown on the dashed line at the maximum force to be applied to the post.

Fig. 12b

Calculations:

Tensile Strength Requirement = Since the tensile strength maximum of 1000lbf (4.45kN) is achieved at the minimum post tip-over load force of 1,000lbf (4.45kN), tensile strength requirement needs no calculation for anchorage strengths below 5000lbf (22.2kN). The tensile strength requirement (per corner) of 1000lbf (4.45kN) must always be used in hardware selection. Points A, B and C represent forces applied to the post and the resulting tensile forces applied to each corner through the base fasteners.

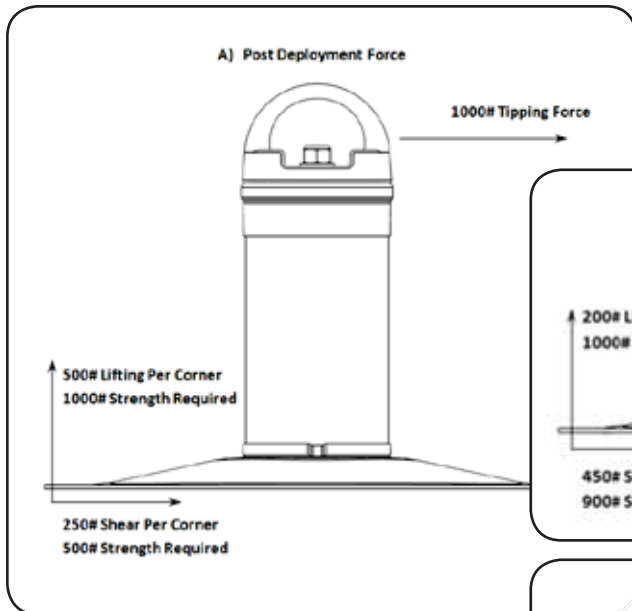
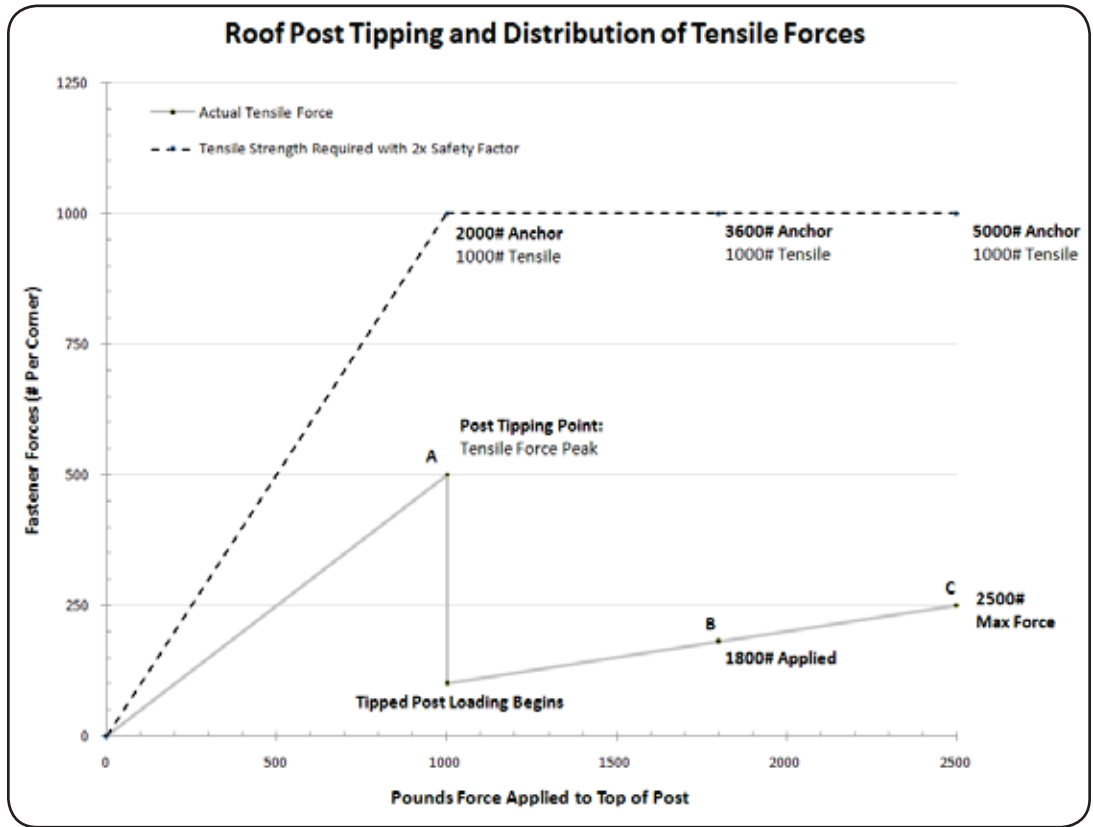

Fig. 12c

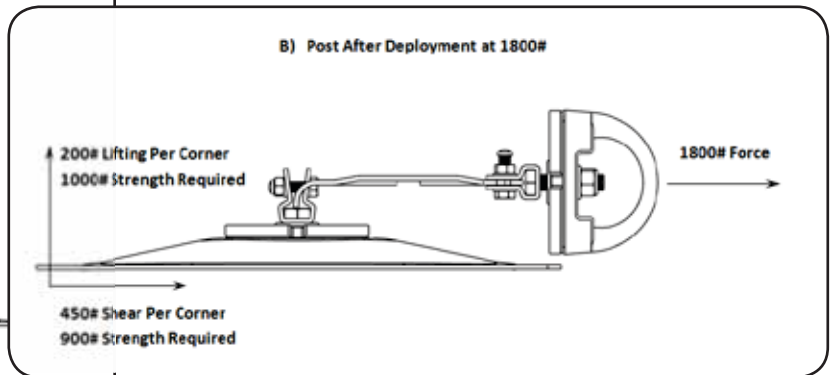

Fig. 12d

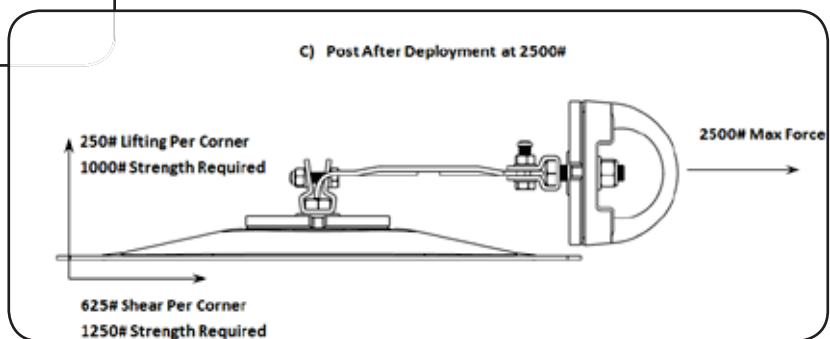
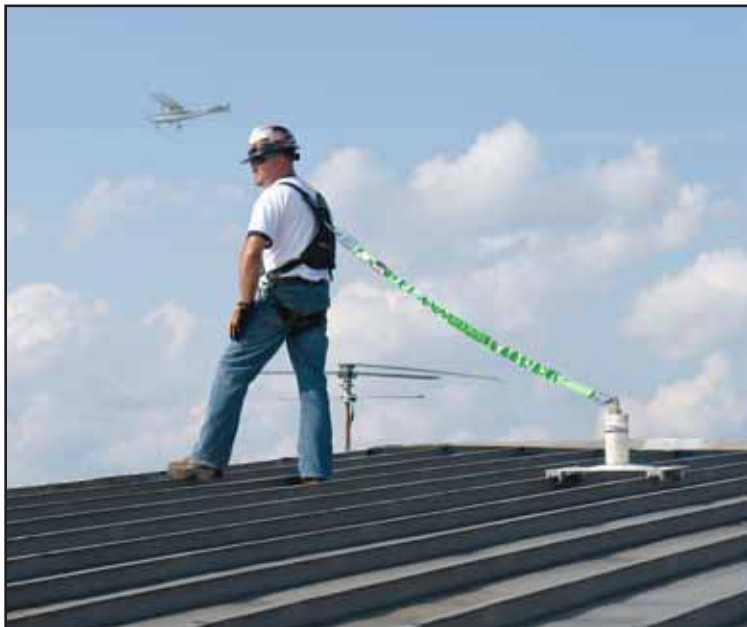

Fig. 12e

5.0 Connection to the Fusion Roof Anchor Post

- Before each use, carefully inspect the roof anchor post in addition to all components of the personal fall arrest system according to the manufacturer's instructions.
- Ensure that there is sufficient fall clearance below the work surface to avoid hitting a lower level or obstruction.
- Avoid working where the connecting device and/or lifeline may come in contact with sharp edges or abrasive surfaces.
- Ensure that all connections within the system are compatible in regards to size, shape and strength.
- Use only approved connecting devices to attach to the Fusion Roof Anchor Post.



1. Properly fit the full-body harness. Refer to the donning instructions provided with the harness.
2. Connect one end of the shock-absorbing lanyard or self-retracting lifeline/fall limiter to the back D-ring of the harness and the other to the D-ring anchor on the roof post. Refer to the instructions provided with the connecting device. Ensure that all connections are compatible and that all connectors, such as snap hooks or carabiners, are closed and locked.

Note: If using a vertical lifeline and rope grab, refer to the instructions provided with the vertical lifeline and rope grab to ensure correct and compatible connection to the roof anchor post and the user's full-body harness. The rope grab must always be oriented on the lifeline with the arrow pointing towards the roof anchor post.

3. Once securely attached, the user may proceed to move about the roof within a recommended work zone.

Approved Connecting Devices

Miller shock-absorbing lanyards, self-retracting lifelines/fall limiters and rope grabs with vertical lifelines are approved for use with the Fusion Roof Anchor Post. A competent person must carefully assess the work area before determining the connecting device to be used, considering the distance from an edge, potential for swing fall, and the edge surface of the roof with which the connecting device may come in contact. Sharp or abrasive edges should be avoided or padded to protect the connecting device.

If a cable self-retracting lifeline is used and the lifeline has the potential to travel over the edge of a flat surface, the potential for cable shear may exist. This is due to the 90 degree bend in the lifeline, the sharp edge of a platform and fall arrest forces created by a fallen worker. In this application, the sharp edge must be padded and a Miller SofStop shock absorber pack (928LS) must be connected between the harness back D-ring and the snap hook at the end of the self-retracting lifeline. Be sure to include the deceleration distance of the shock absorber pack when calculating fall clearance. Contact Miller Technical Services to obtain Technical Brief 102 "Horizontal Use of Self-Retracting Lifelines" for more information regarding this application.

If a rope grab with vertical lifeline is used, the vertical lifeline must remain taut at all times between the user and the anchorage connection. The rope grab must always be oriented on the lifeline with the arrow pointing towards the roof anchor post.

Read and follow all instructions and warnings provided with the connecting device at the time of shipment. For application specific questions, contact Miller Technical Services.

6.0 Fall Clearance

It is important to understand how to calculate potential fall clearance necessary to avoid contact with a lower level or obstruction. Refer to the following fall clearance calculation diagrams for shock-absorbing lanyards and self-retracting lifelines/fall limiters used in conjunction with the Fusion Roof Anchor Post. When using a rope grab with vertical lifeline, refer to the instructions included with the device at the time of shipment for assistance in calculating fall clearance distance. Remember that the vertical lifeline must remain taut at all times between the user and the anchorage connection when used in this application. Miller Fall Protection always recommends that a 3ft. (.9m) safety factor be included in all fall clearance calculations. If there is any question about calculating fall clearance distance, please contact Miller Technical Services at 800.873.5242 before using this device.

Fall Clearance Calculation when using a Shock-Absorbing Lanyard

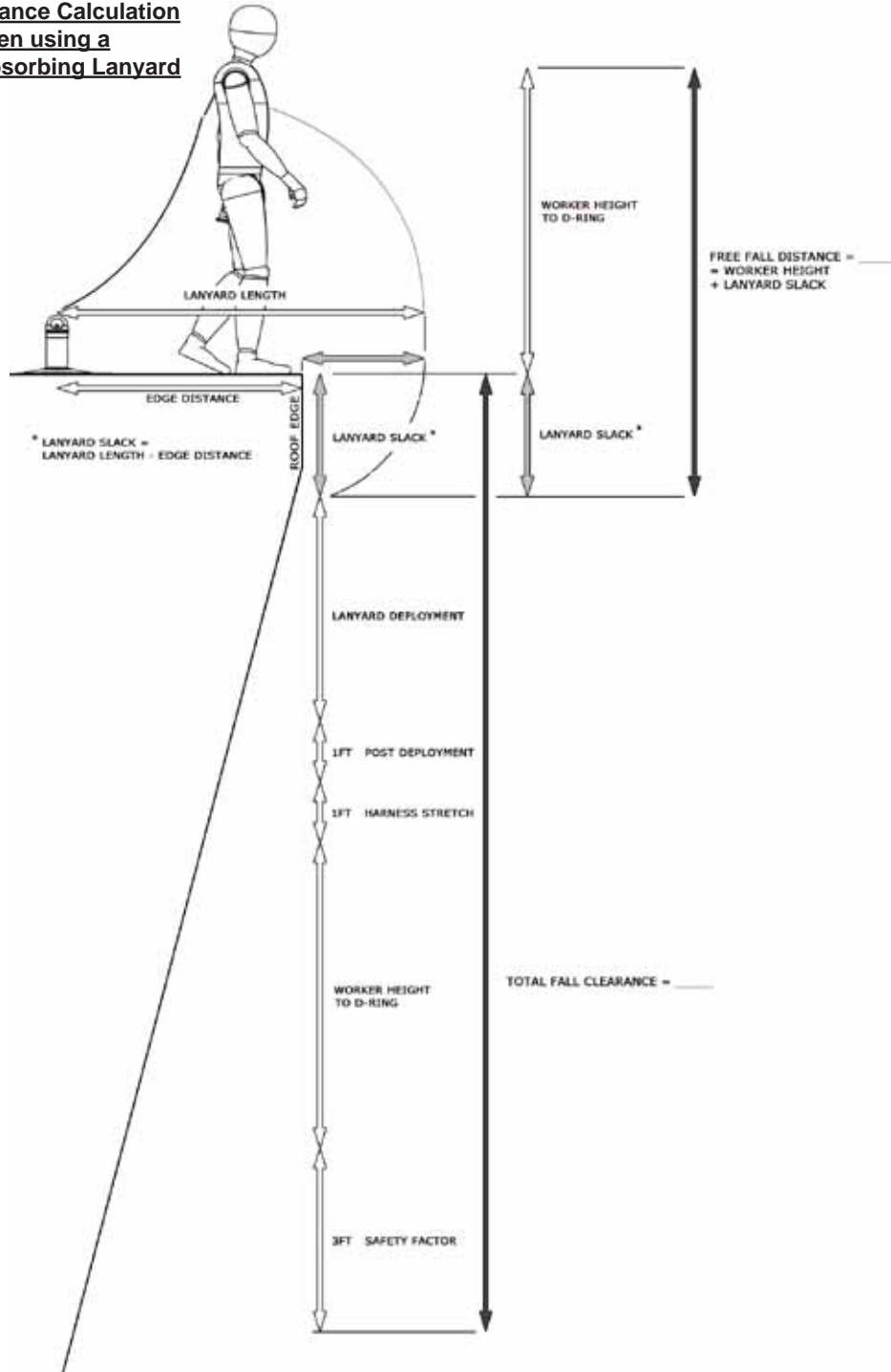

**Fall Clearance Calculation
when using a
Self-Retracting Lifeline/Fall Limiter**

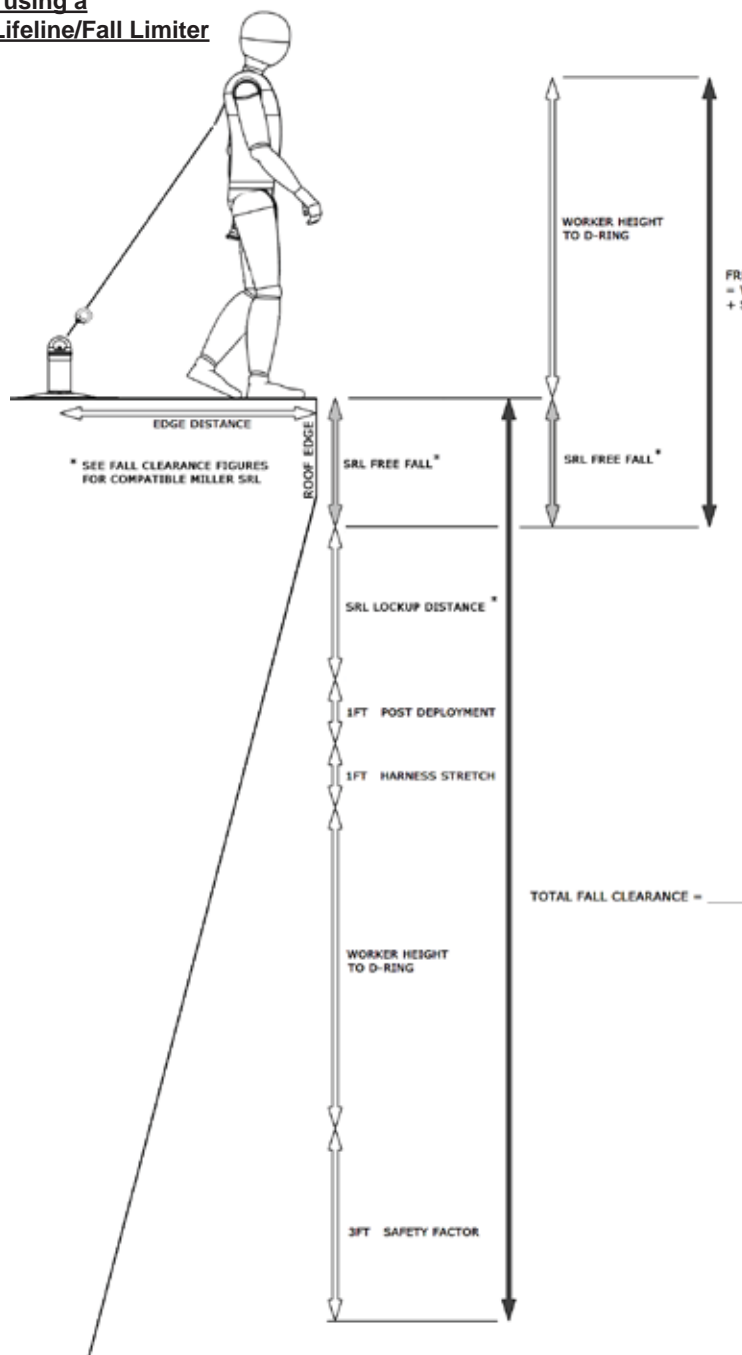

NOTES: This diagram assumes the user is working in relation to the anchor so as to minimize any possibility of swing fall. Swing falls can cause serious injuries to the user and increases the amount of fall clearance required.

This diagram also assumes the user is not using a cable self-retracting lifeline which may have the potential to travel over a sharp 90° edge (see Approved Connecting Devices in 5.0 Connection to the Fusion Roof Anchor Post). If that potential exists, a shock absorber pack must be used in addition to the SRL and the additional deceleration distance must be included in the fall clearance calculation.

7.0 Training

It is the responsibility of the user and the purchaser of this equipment to assure they are familiar with these instructions and are trained in the proper use, installation, operation, maintenance and limitations of this product. Training should be conducted periodically and without exposing the trainee to a fall hazard.

Training is an integral part of our Total Solution in fall protection, since no fall protection equipment – regardless of how effective – can save an employee who is not trained in its use. To meet this crucial requirement, Miller Training provides the knowledge and skills necessary to achieve a safe, more productive work environment. For more information on Miller Training, contact a representative today: 800.873.5242.

8.0 Inspection and Maintenance

Inspection

Miller Anchorage Connectors are designed for today's rugged work environments. To maintain their service life and high performance, all components should be inspected frequently. Anchorage connectors must be visually inspected by the user before each use and inspected by a Competent Person on a regular basis. **Replace equipment if any of the defective conditions explained in this manual are found.**

- Inspect entire product for any of the following: bent, cracked, distorted, worn, malfunctioning or damaged parts; loose fasteners or missing parts/components; deterioration; deformation; corrosion; signs that indicate the product has been subjected to a fall arrest; or any other indications of damage/problems that may affect the integrity and operation of the product. If in doubt, contact the manufacturer.
- Check D-ring anchor to ensure that it is securely attached to the roof anchor post (see 4.1 Roof Anchor Post Assembly) and does not show any signs of damage as listed above.
- Check all fasteners and corresponding torque values to ensure that the roof anchor post is securely attached to the roof structure (see 4.2 Base Installation). Inspect the condition of the roof to ensure that it still meets all anchorage requirements.
- Inspect the components of the personal fall arrest system according to the manufacturer's instructions.
- The Fusion Roof Anchor Post should always be in the upright position. If the anchor has been subjected to fall arrest forces the post will be tipped over in the direction of loading.

Devices that do not pass inspection
or have been subjected to fall arresting forces
must be removed from service.

Cleaning and Storage

Basic care of all Miller Fall Protection equipment will prolong the life of the unit and will contribute toward the performance of its vital safety function. Periodically clean the device with a cloth dampened with water and mild soap or detergent to remove any dirt, paint, corrosives, contaminants, or other materials that may have accumulated.

Servicing

Servicing of Miller Fall Protection equipment must only be carried out by Miller Fall Protection or persons or entities authorized in writing by Miller Fall Protection. A record log of all servicing and inspection dates for this device must be maintained. Only original Miller replacement parts are approved for use in this device. Non-repairable devices that do not pass inspection must be disposed of in a manner to prevent inadvertent further use. Contact Miller Technical Services at 800.873.5242 if you have any questions.

Labels

MILLER Fusion™ Roof Anchor Post

⚠ WARNING

The Fusion Roof Anchor Post is designed to be used as a single anchorage point for a personal fall arrest system or as an intermediate anchorage post for approved Miller horizontal lifeline systems. Do not use the Fusion Post as an end or corner anchorage in a horizontal lifeline application unless approved by Miller Fall Protection.

Manufacturer's instructions supplied with this product at the time of shipment must be followed for installation, proper use, inspection and maintenance. Failure to do so could result in serious injury or death. Only trained personnel are permitted to use this equipment. Contact Miller Fall Protection if instruction manual is needed.

- Inspect before each use according to the manufacturer's instructions. If the device is subjected to fall arrest forces or if inspection reveals an unsafe or defective condition, it must be taken out of service.
- Personal fall protection—a full-body harness and shock-absorbing lanyard or self-retracting lifeline—must be used with this device. Ensure that all connections are compatible.
- Ensure that there is adequate fall clearance. Refer to instructions.
- A rescue plan, and the means to implement it, must be in place when using this equipment.
- Product must not be altered in any way.
- Refer to instructions for information on permissible direction of loading.
- Use caution when working in or near hazardous environments. Equipment must not be exposed to chemical, electrical or thermal sources which may affect the integrity of the product. Avoid contact with sharp edges and abrasive surfaces.

MILLER

by Honeywell

⚠ ADVERTISSEMENT / ACHTUNG / ADVERTENCIA

Le poteau d'ancrage de toiture Fusion est conçu pour être utilisé comme simple point d'ancrage pour un système individuel d'arrêt de chute ou comme poteau d'ancrage intermédiaire pour des systèmes de filins horizontaux approuvés de Miller. Ne pas utiliser le poteau Fusion comme ancrage d'extrémité ou de coin pour une application de filin horizontal à moins d'approbation de Miller Fall Protection.

Les instructions du fabricant fournies avec ce produit lors de l'expédition doivent être observées pour l'installation, l'usage adéquat, l'inspection et l'entretien, sans quoi il y a risque de blessures graves ou mortelles. Seul le personnel dûment formé peut se servir de cet équipement. Pour se procurer un manuel d'instructions, communiquer avec Miller Fall Protection.

Der Fusion Dachpfosten kann als Einzelschlagpunkt oder als Zwischenpfosten für zertifizierte horizontale Miller Absturzschutzsysteme genutzt werden. Der Fusion darf nicht als Endbefestigung oder Kurvenpfosten eingesetzt werden. Ausser die Nutzung wurde von Miller Fall Protection für den Einzelfall freigegeben.

Die vom Hersteller zur Verfügung gestellte Anleitung ist für die Installation, die Nutzung, die Überprüfung und Wartung massgebend. Nichtbeachtung kann zu ernsthaften Verletzungen oder zum Tod führen. Nur geschulten Personen ist die Nutzung gestattet. Sollten Sie eine Anleitung benötigen nehmen Sie bitte Kontakt zu Miller Fall Protection auf.

El poste de anclaje para techos Fusion está diseñado para usarse como punto de anclaje único para un sistema personal de detención de caídas o como poste de anclaje intermedio para sistemas de cuerda salvavidas horizontales Miller aprobados. No use el poste Fusion como punto de anclaje extremo o esquinero en una aplicación de cuerda salvavidas horizontal a menos lo apruebe Miller Fall Protection.

Es preciso seguir las instrucciones del fabricante suministradas con el producto al momento del embarque en relación con la instalación, uso correcto, inspección y mantenimiento. No hacerlo podría tener como consecuencia lesiones graves o mortales. Solamente personal entrenado está autorizado a utilizar este equipo. Si necesita el manual de instrucciones comuníquese con Miller Fall Protection.

Insert Variable Label

LB1137 Rev. A



MILLER® FALL PROTECTION PRODUCTS
TOTAL SATISFACTION ASSURANCE

At Miller Fall Protection, we have been providing quality Miller brand fall protection equipment to millions of workers worldwide since 1945.

LIMITED LIFETIME WARRANTY
BACKED BY OVER 65 YEARS IN THE FALL PROTECTION BUSINESS

We sincerely believe that our fall protection equipment is the best in the world. Our products endure rigorous tests to ensure that the fall protection equipment you trust is manufactured to the highest standards. Miller fall protection products are tested to withstand normal wear and tear, but are not indestructible and can be damaged by misuse. Our Limited Lifetime Warranty does not apply to normal wear and tear or abusive treatment of the product.

In the unlikely event that you should discover defects in either workmanship or materials, under our Limited Lifetime Warranty, we will repair or replace the product at our expense. If a replacement is necessary and your product is no longer available, a comparable product will be substituted. Should a product issue surface, contact us at 800.873.5242.

Manufacturing specifications are subject to change without notice.

PRODUITS MILLER® FALL PROTECTION
ASSURANCE DE SATISFACTION TOTALE

Chez Miller Fall Protection, nous fournissons des équipements de protection contre les chutes de marque Miller de qualité à des millions de travailleurs dans le monde entier depuis 1945.

GARANTIE LIMITÉE À VIE
ASSURÉE GRÂCE À PLUS DE 65 ANS PASSÉS DANS LE DOMAINE DE LA PROTECTION CONTRE LES CHUTES

Nous croyons sincèrement que notre équipement de protection contre les chutes est le meilleur au monde. Nos produits sont soumis à des tests rigoureux, afin d'assurer que les équipements de protection contre les chutes dans lesquels vous avez confiance sont fabriqués selon les normes les plus exigeantes. Les produits de protection contre les chutes Miller sont soumis à des essais pour vérifier qu'ils résistent à une usure normale; ils ne sont cependant pas indestructibles et peuvent s'endommager en cas de mauvaise utilisation. Notre garantie limitée à vie ne s'applique pas à l'usure normale ou à un usage abusif du produit.

Dans le cas peu probable où vous découvririez des défauts, soit de fabrication, soit de matériau, dans le cadre de notre garantie à vie, nous réparerons ou remplacerons le produit à nos frais. En cas de remplacement, si votre produit n'est plus offert, vous recevrez un produit comparable. En cas de problème sur un produit, nous contacter au 800-873-5242.

Les caractéristiques de fabrication peuvent être modifiées sans préavis.

PRODUCTOS ANTICAÍDAS MILLER®
GARANTÍA DE SATISFACCIÓN TOTAL

En Miller Fall Protection, venimos suministrando desde 1945 los equipos de protección anticaídas con la calidad Miller a millones de trabajadores en todo el mundo.

GARANTÍA LIMITADA DE POR VIDA
NOS RESPALDAN MÁS DE 65 AÑOS EN LA FABRICACIÓN DE EQUIPO ANTICAÍDAS

Sinceramente creemos que su equipo de protección contra caídas es el mejor del mundo. Nuestros productos resisten rigurosas pruebas para garantizar que el equipo de protección contra caídas en el que usted confía está fabricado de conformidad con las normas más elevadas. Los productos anticaídas Miller son sometidos a pruebas para que resistan el desgaste normal, pero no son indestructibles y su incorrecta utilización puede dañarlos. Nuestra Garantía limitada de por vida no se aplica al desgaste normal ni al maltrato del producto.

En el poco probable caso de que usted descubriera defectos de mano de obra o materiales, por nuestra Garantía limitada de por vida, repararemos o sustituiremos el producto por cuenta nuestra. Si un reemplazo es necesario y nuestro producto ya no está disponible, se lo sustituiremos por otro comparable.

En caso de que surja un problema con el producto, contáctenos al 800.873.5242.

Las especificaciones de fabricación están sujetas a modificaciones sin previo aviso.



by Honeywell

Toll Free: 800.873.5242
Fax: 800.892.4078

Download this manual at: www.millerfallprotection.com
Téléchargez ce manuel à l'adresse: www.millerfallprotection.com
Puede bajar por Internet este manual en: www.millerfallprotection.com

Honeywell Safety Products
P.O. Box 271, 1345 15th Street
Franklin, PA 16323 USA