

SMB SYSTEM S

0,6 kg

OSHA 1926.502

Item	Part numbe
1+2	10728
1	11570
2	11022
3	10730
4	100326

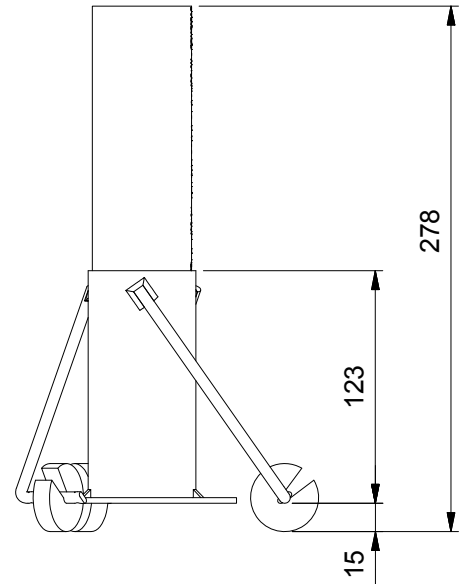
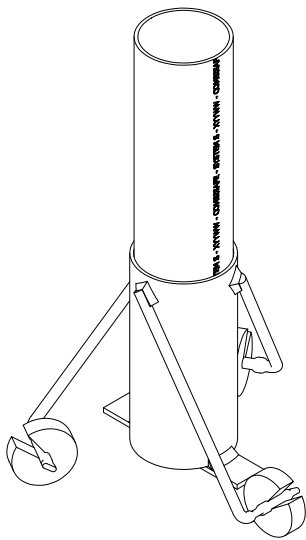
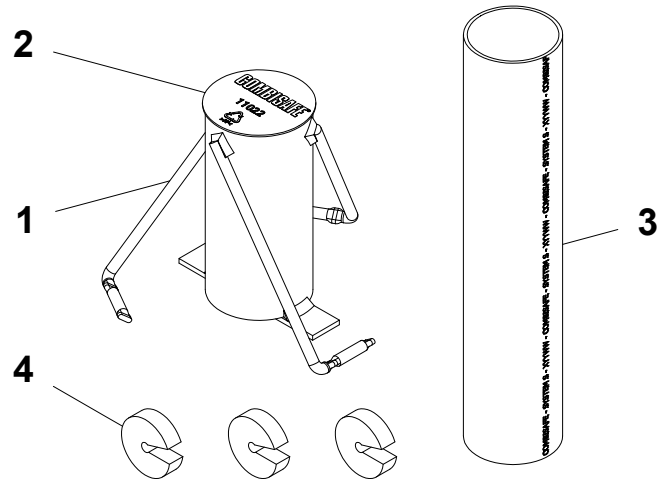

[mm]

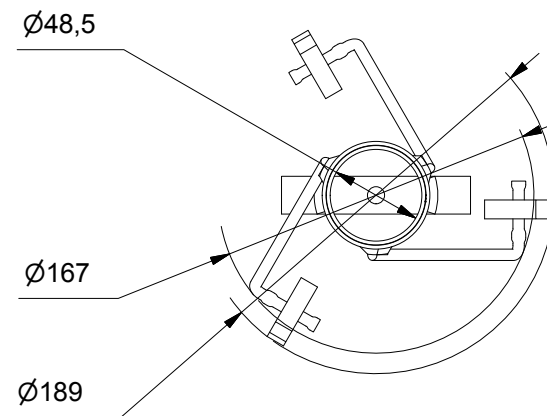

TI M1233-1

© Combisafe International AB



1.

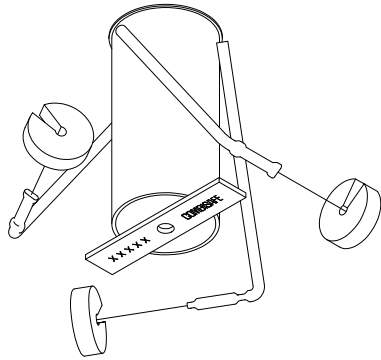

2.

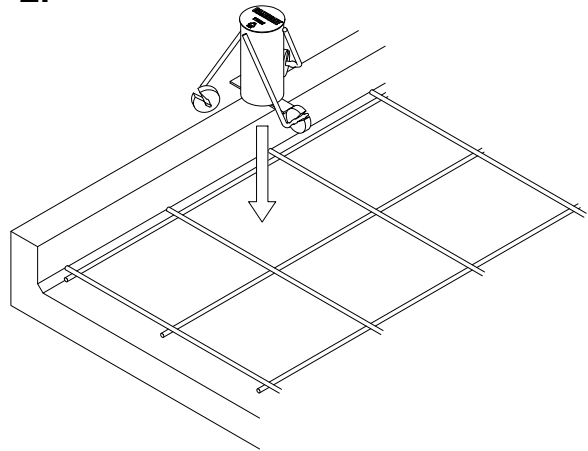

3.

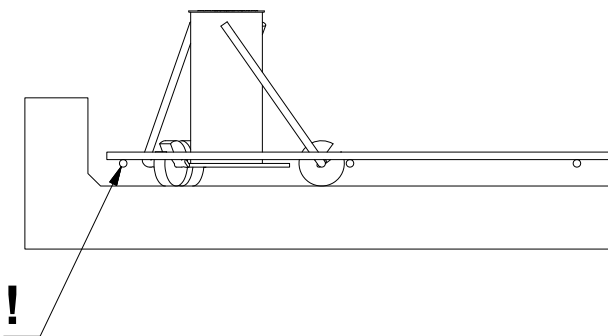

4.

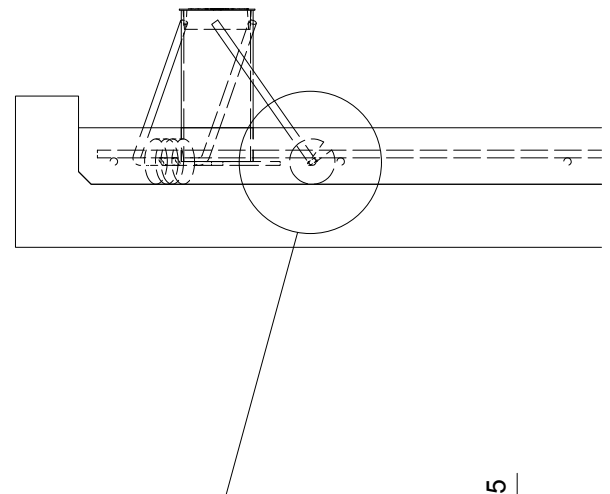

NB!

