

# Installation & maintenance manual

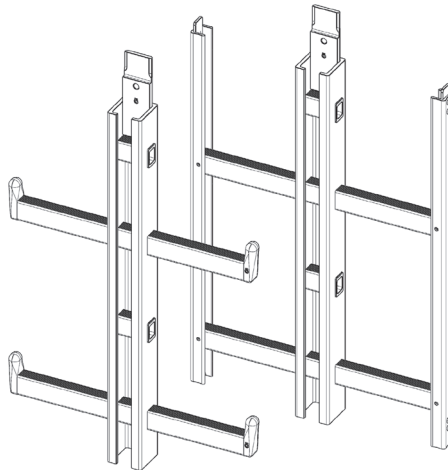

## Aluminium ladders Söll GlideLoc® fall arrest system

EN 353-1:2014+A1:2017



	Ref./Part No.
Y-spar ladder, anodised aluminium	YAL
Twin ladder, anodised aluminium	ZAL
End stop	26026, 11634, 50165873-001
Foldable footrest	RP-KAL
Pivotable footrests	15391, 16547
Pivotable aluminium cover plate	BL-ALKL
Cover plate for hooking	BL-STZE
Exit section	AV-AL
Rotary exit section	UV-AL
Twisted change over rail	UEBERSTIEG
Pivot roof exit	23144, 24946
Turntable	15299, 20793
Ho-Ver turntable	23892
Shaft entering device	17410
Insertion ladder	<i>see catalogue</i>
Movable ladder section	22404, 24360

# Index

1	INTRODUCTION	4
1.1	Product description	5
1.2	Compatible Components	6
1.3	Protection provided by the fall arresting system	6
1.4	Performance	6
1.5	Limitations and capabilities	7
1.6	Training	7
2	PRE-USE INFORMATION	8
2.1	Transportation, storage and packaging	8
2.2	Pre-use checks	8
2.3	Inspection before installation	8
2.4	Basics for installation	9
2.4.1	General information	9
2.4.2	Tightening torques	9
2.4.3	Required personnel and equipment for easy mounting	10
2.4.4	Ladder marking	10
2.4.5	Fixation of temporary ladders	10
2.5	Installation instructions	11
2.5.1	Ladder sections	11
2.5.2	End stops and recess	12
2.5.3	Upper ladder end with and without rail reinforcement	13
2.5.4	Folding and pivotable footrests	14
2.5.5	Pivotable aluminium cover plate (left/right hinged)	15
2.5.7	Exit section	18
2.5.8	Rotary exit section	19
2.5.9	Twisted change over rail	20
2.5.10	Pivot roof exit left/right	21
2.5.11	Turntable with 4 fixation brackets	22
2.5.12	Turntable with holder	24
2.5.14	Shaft entering device	26
2.5.15	Insertion ladder for hooking from below	27
2.5.16	Insertion ladder for hooking in from top	29
2.5.17	Movable ladder section	30
3	USE	32
3.2	Using the fall arrest system	32
3.3	Emergency procedures	32
4	AFTER-USE INFORMATION AND MAINTENANCE	33
4.1	Cleaning	33
4.2	Inspection	33
4.3	Acceptance and regular inspections	34
4.4	Repair	34
5	MISCELLANEOUS	35
5.1	Identification	35
5.2	Notified Body	35
	APPENDIX 1: Approval and inspection check list	36
	APPENDIX 2: Inspections and repairs	42
	Further remarks	43

**KEEP THIS MANUAL FOR FUTURE USE - DO NOT THROW AWAY!**

**Explanation of symbols**

	<p><b>Danger!</b> Improper or careless handling could cause accidents leading to falls resulting in injuries or even death.</p>
	<p><b>Warning!</b> Non-compliance could result in serious injuries.</p>
	<p><b>Important!</b> Useful information and user hints are given here.</p>

**Changes in this issue: -**

# 1 INTRODUCTION

Honeywell Fall Protection Deutschland GmbH & Co.KG KG (the "Manufacturer") provides with its Söll GlideLoc system a vertical guide rail which can be applied in several options and materials. This manual refers to the installation and use of the Söll GlideLoc rail as an **aluminium ladder** with optional ancillary products.

All products referred to in this manual can be found in the Technical Selection Guide of Honeywell Fall Protection Deutschland GmbH & Co.KG.

Products contained in this manual are rated class III personal protective equipment (EU 2016/425).

**Before installing and using this system you must read and understand this instruction manual and any additional instructions provided during installation training or given with the system at the time of shipment.**

**Do not install this equipment or carry out any modifications on this system unless you are properly trained to do so.**

Please note: The operating company of a vertical fall arrest system must ensure that instruction manuals

- are either kept in a safe and dry location near the system
- are always kept in an easily accessible location that is known to all system users.

These instructions are provided in the language(s) of the countries in which the Manufacturer is selling the Söll GlideLoc system. To protect the safety of installers and users, the Söll GlideLoc system should not be used in any country in which these instructions are not available in local language. If a reseller sells the Söll GlideLoc system into any such country, the reseller is responsible for translating these instructions into the relevant language(s).



**Danger!**

**Failure to comply with these user instructions may result in serious injury or death!**

The Manufacturer of this product is Honeywell Fall Protection Deutschland GmbH & Co. KG, Seligenweg 10, 95028 Hof, Germany.

For any technical concerns or questions please find our contact details below. For warranty related concerns please contact your dealer.

## Contact

For Southern Europe: System Customer Service (Vierzon, France)

Honeywell Fall Protection France, 35-37 rue de la Bidauderie, 18100 Vierzon, France

- Phone: +33 248 53 00 80
- Email: [lignedevie@honeywell.com](mailto:lignedevie@honeywell.com)

For Northern Europe: System Customer Service (Hof, Germany)

Honeywell Fall Protection Deutschland GmbH & Co. KG, Seligenweg 10, 95028 Hof, Germany

- Phone: +49 9281 8302 0
- Email: [scs-hof@honeywell.com](mailto:scs-hof@honeywell.com)

## 1.1 Product description

Söll GlideLoc is a vertical guide rail system meeting the EN 353-1 standard. The system protects people who are ascending or descending, from falls from height while providing them with significant freedom of movement.

This manual refers to the use of the Söll GlideLoc rail as a **aluminium ladder** with optional ancillary products (“Components”) with regard to which see section 1.2.

Special mounting brackets must be used to fix Söll GlideLoc system to the substructure, when used as rail for ladders.

A special Söll GlideLoc guided-type fall arrester (hereinafter referred to as a “fall arrester”) must be used to connect the user to the anchor rail of the ladder. Fixed or flexible end stops must be used to secure the fall arrester against unintentional disengagement from the rail.

The ladders can be installed in various configurations and allow assembly with Components such as footrests, exit sections or turntables.

The typical Components of the Söll GlideLoc fall arrest system are (fig 1.1):

- 1:ladder with anchor rail
- 2:connector
- 3:openable end stop (bottom and top application)
- 4:rigid end stop
- 5:fall arrester (separate user manual)
- 6:mounting bracket
- 7:footrest

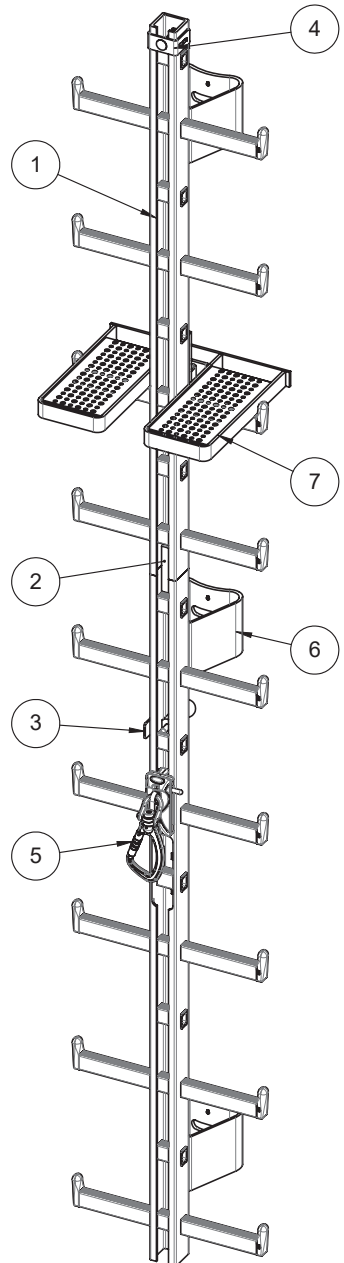

Fig 1.1: Typical components of the Söll GlideLoc fall arrest system

## 1.2 Compatible Components

Söll GlideLoc is designed to be combined with Components such as ladders, turntables, footrests, exit sections and others as described herein. As stated in section 1.1, a Söll GlideLoc fall arrester is necessary to connect a user to the anchor rail. The Manufacturer has only CE certified the Söll GlideLoc fall arresters for use with the Söll GlideLoc rails, and the Manufacturer therefore does not warrant that fall arresters of any other manufacturer will operate safely with the Söll GlideLoc system.

All Components which are designed to be used in a Söll GlideLoc vertical fall arrest system can be found in the Technical Selection Guide.

The Söll GlideLoc system should be used only in combination with EN 361 compliant full-body harnesses. Only certified fall arrest slings or rings ("A"-marking) must be used for attaching the fall arrester to the full-body harness.



**Danger!**

**Failure to comply with the above will expose the user to risks of fall from height!**

**Please refer also to the user instructions of other personal protective equipment that may be used in combination with a Söll GlideLoc system.**

## 1.3 Protection provided by the fall arresting system

The purpose of the Söll GlideLoc vertical fall arresting system is to arrest a fall of a user when ascending/descending or from his high-altitude working position and to protect him against serious injuries or death caused by a fall from height.

## 1.4 Performance

The vertical fall arrest system was tested in accordance with EN 353-1:2014+A1:2017 and is consequently equipped according to the type test for a static force of 15 kN. Minimum distance is 3 meters between each user but at least two times maximum fixation distance.

The vertical fall arrest system is supposed to be installed permanently to a substructure which must comply with appropriate requirements, calculated according to the intended use of the system.

Please note that for the first two metres the user may not be protected against hitting the ground and particular caution is necessary when ascending or descending.

## 1.5 Limitations and capabilities

The allowed operating temperature range is between **-40°C and +60°C**.

When not in use the ambient temperature must not exceed 100°C.

The minimum user weight must not be less than **40 kg**. The maximum user weight incl. clothes and equipment must not exceed **140 kg**. Please refer also the marking on the fall arrester.

Further detailed limitations and capabilities please refer to section **"2.4 Installation"**.

**The Söll GlideLoc fall arrest system is not intended to be used in adventure/activity parks.**

**The Söll GlideLoc fall arrest system must not be used for transport or for lifting of loads.**

**Danger!**



**Failure to comply with these provisions will expose the user to risks of fall from height!**

## 1.6 Training

The installation of the products defined herein have to be conducted by qualified people who have appropriate training and knowledge to ensure proper installation of the system.

For the safety of those who use the Söll GlideLoc fall arrest system and work with it, it is important that they are physically fit and are not under the influence of medication, drugs or alcohol.

Operator of a fall arrest system is responsible and liable for the training/ introduction of users with respects to the safe use of such a system. Manufacturer of the Söll GlideLoc fall arrest system offers appropriate training to the terms of its current price list.

Users of the Söll GlideLoc fall arrest system must be trained in the safe use of it by the operator. An appropriate training by the manufacturer may be offered.

User and Operator should inform themselves about the proper use of Personal protective equipment (PPE) used in connection with the Söll GlideLoc fall arrest system, protecting them against fall from heights. Understand the mode of operation of such PPE. In case of doubt, take no risks and contact the manufacturer of the correspondent PPE.

In addition to herein provided trainings covering installation and use of the Söll GlideLoc fall arrest system and connected PPE, we advise that user must be familiarized with the relevant accident prevention and safety regulations (e.g. local law, company-internal guidelines) and comply with them. If there are contradictions between the individual documents, please contact Honeywell Fall Protection Deutschland GmbH & Co. KG.

## 2 PRE-USE INFORMATION

### 2.1 Transportation, storage and packaging

Ensure that the Söll GlideLoc components are transported and stored in a clean, dry, ventilated area, free of exposure to fumes. Avoid corrosive, overheated or frozen atmosphere or other environmental effects which could impair the functionality of the equipment.

System components made of stainless steel are delivered in pickled finish ex works. Ensure that storage and further processing is suitable for stainless steel.

Make sure that the system components will not be damaged during storage and transportation activities. Do not throw or drop any parts of the system!

To avoid any damages, defects or loss of parts, the system components should be transported and stored in their original packaging.

### 2.2 Pre-use checks

Ensure that the Söll GlideLoc fall arrest system is inspected before each use. The fall arrest system must be in perfect working condition and must operate properly before and during every use of the device. Ensure that the system and the components are not deformed or damaged.

The fall arrest system must not be used after the event of a fall, if defects are detected or if there are doubts that the system can safely be used. The system must be removed from service until an authorized person or body (as defined in chapter "4 After-use information and maintenance") confirms in writing that the system is fit for use. In case of doubt or if required under the before mentioned circumstances, the fall arrester is to be sent back to the manufacturer.

Before every use, check if the end stop at the access point works perfectly:(i) pull the ball knob; (ii) let the ball knob go, and (iii) the locking pin must lock automatically in the initial position. If not, please contact operator for further assistance.

Before every use, check that your personal protective equipment such as lanyard with shock absorber and/or full-body harness and helmet are fit for use, and that it is used in safe working conditions.

**Before every use, check that the fall arrester is free from any damages (deformations, cracks etc.). Follow the instructions of the fall arrester manual.**

### 2.3 Inspection before installation



#### **Warning!**

**Before installation a qualified engineer or technician must check whether the substructure on which the Söll GlideLoc system is to be fixed can withstand the stress (refer to section „1.4 Performance“) resulting from a fall and certify this (certificate of stability).**

Manufacturer's installation instructions and installation suggestions as per EN 353-1 standard must be followed at the time of installation.



## 2.4 Basics for installation

### 2.4.1 General information

#### a) Project planning

Project planning must be done before installation including certificate of stability. The installation should be inspected by a qualified person, tolerances should be determined and precise drawings should be prepared. This project planning enables determination of appropriate fastening types that can be derived from the following technical elements: quality of substructures, possible fixation distances of the ladder and the number of users planned to use the fall arrest system at the same time.

#### b) On-site installation

Adhere to the prevailing accident prevention and safety regulations of the respective country while installing. Follow the installation notes of the latest EN 353-1 standard and generally accepted technical standards. It is recommended that the installer and the customer should coordinate installation planning based on the results of the project planning and the installation site inspection.

Components must be handled carefully. Guide rails or ladder sections must not be thrown. Before installation, make sure that rail sections are free from dirt - in particular the connecting surfaces. They should not come into contact with cement, mortar or similar substances. Remnants of mortar must be wiped off immediately. Especially the sliding surfaces for the fall arrester on the inside and outside of the guide rail must be free of dirt.

Installation dimensions and tolerances defined in "2.5 Installation instructions" have to be respected.

Damaged parts may neither be used nor repaired but must be replaced by new ones.

#### c) Acceptance tests after installation

After installation, the installer and/ or the customer together with an authorized person or body (see chapter "4 After-use information and maintenance") must conduct functional and acceptance tests and maintain a log for them. Especially check that

- the tightening torques of screw connections prescribed in article 2.4.2 have been adhered to,
- the fall arrester can be guided smoothly through the anchor rail,
- all information has been provided on the identification plate,
- no damaged parts were used,
- the checks according the check list at the end of this manual have been carried out.

### 2.4.2 Tightening torques

When tightening mounting screws in **steel quality 8.8** used in combination with tooth lock washers the following tightening torque range is recommended:

Screw size:	M 10	M 12	M 16
	20 Nm	25 Nm	60 Nm

When tightening mounting screws in **stainless steel** in combination with self-locking nuts (DIN 985) supplied by the manufacturer the following torque range is recommended:

Screw size:	M 10	M 12	M 16
	25 Nm	30 Nm	65 Nm

### 2.4.3 Required personnel and equipment for easy mounting

- 2 people
- 2 full-body harnesses according to EN 361
- 2 lanyards with energy absorber acc. to EN 354/355
- 2 Söll GlideLoc fall arresters
  
- 2 open wrenches, size 19
- 2 open wrenches, size 17
- 1 open wrench, size 13
- 1 open wrench, size 10
- 1 torque wrench 10-50 Nm with nuts sizes 13,17,19
- 1 open wrench for structure bolts as required
- 1 rubber hammer

### 2.4.4 Ladder marking

**Fig. 2.0** - Top marking of the ladder section:  
When mounting the ladder, the red plastic ribbon must always point upwards.



#### **Danger!**

**The red plastic ribbon at the top of each ladder section is not an end stop!**

**It will not prevent the fall arrester from slipping out of the rail!**

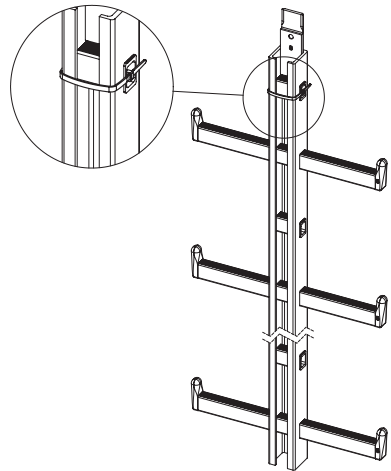

### 2.4.5 Fixation of temporary ladders

Temporary ladders, for example insertion ladders (see sections 2.5.16; 2.5.17) may only be installed in combination with matching fixation elements as provided in the Technical Selection Guide.

## 2.5 Installation instructions

### 2.5.1 Ladder sections

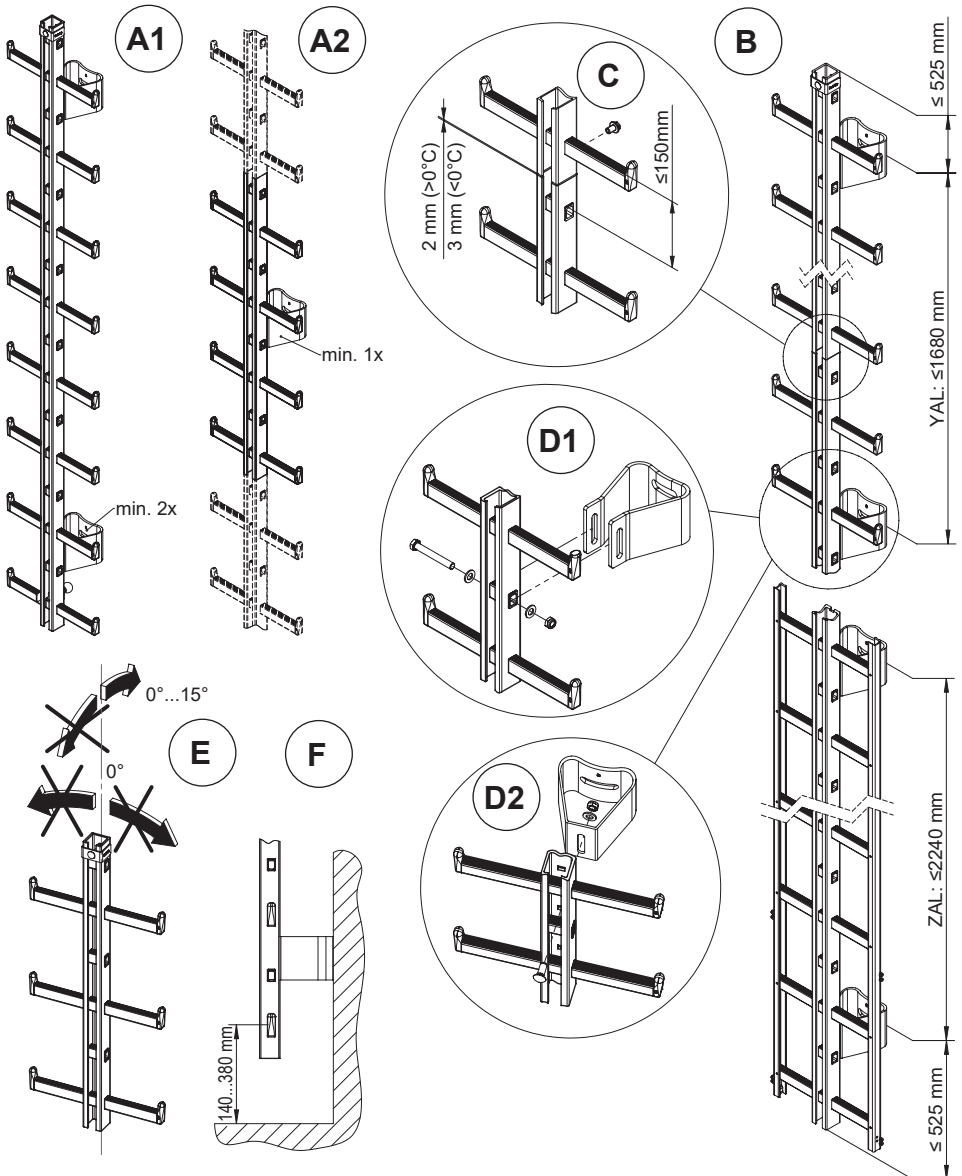

**Fig. 2.1** - Installing the ladder sections: Number of fixations per climbing path (A1) and per ladder section (A2), fixation distances (B), ladder joint (C), rear (D1) and lateral (D2) fixation brackets, ladder inclination (E) and distance between ground and 1st ladder rung (F)

## 2.5.2 End stops and recess

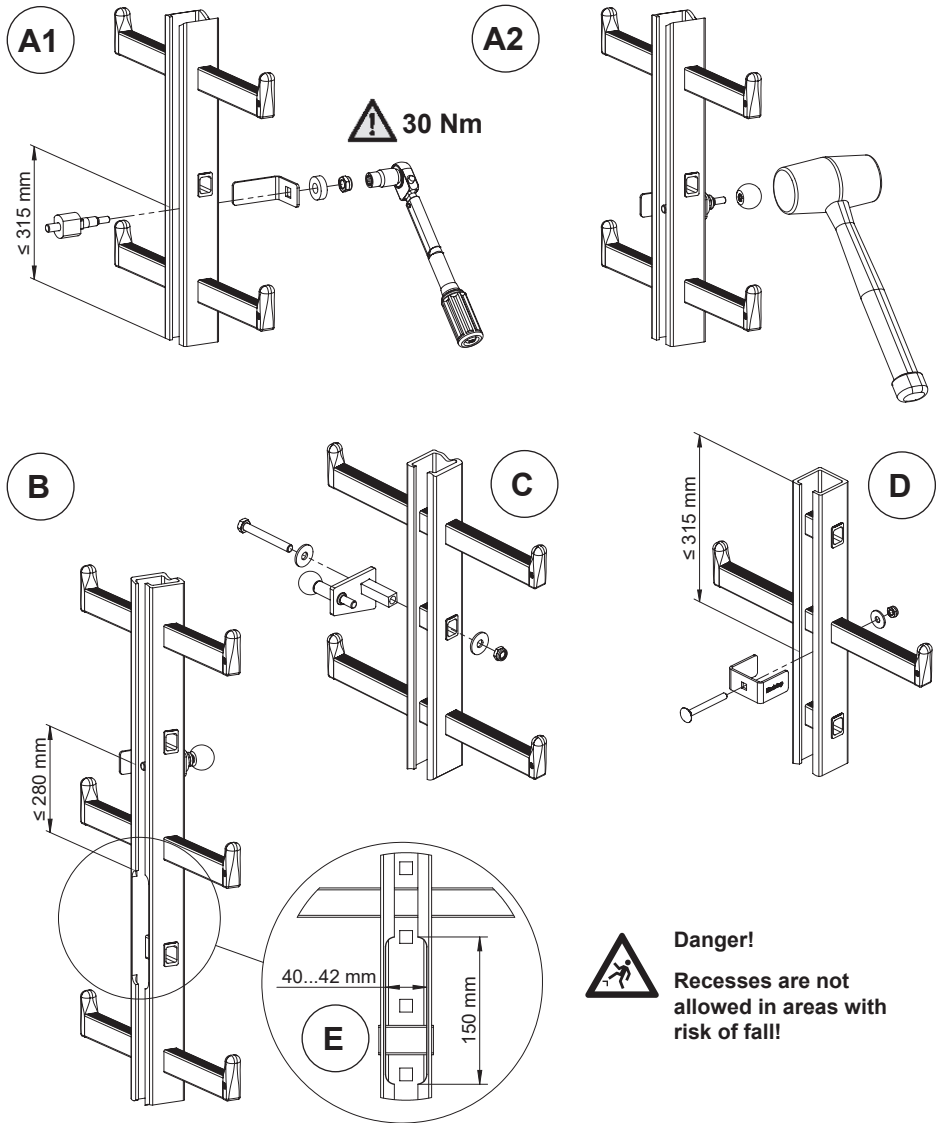

Fig. 2.2 - Installing the end stops

- A1/A2: Standard end stop
- B: End stop above a rail recess
- C: Lateral end stop for confined space
- D: Rigid end stop, top
- E: Recess dimensions

### 2.5.3 Upper ladder end with and without rail reinforcement

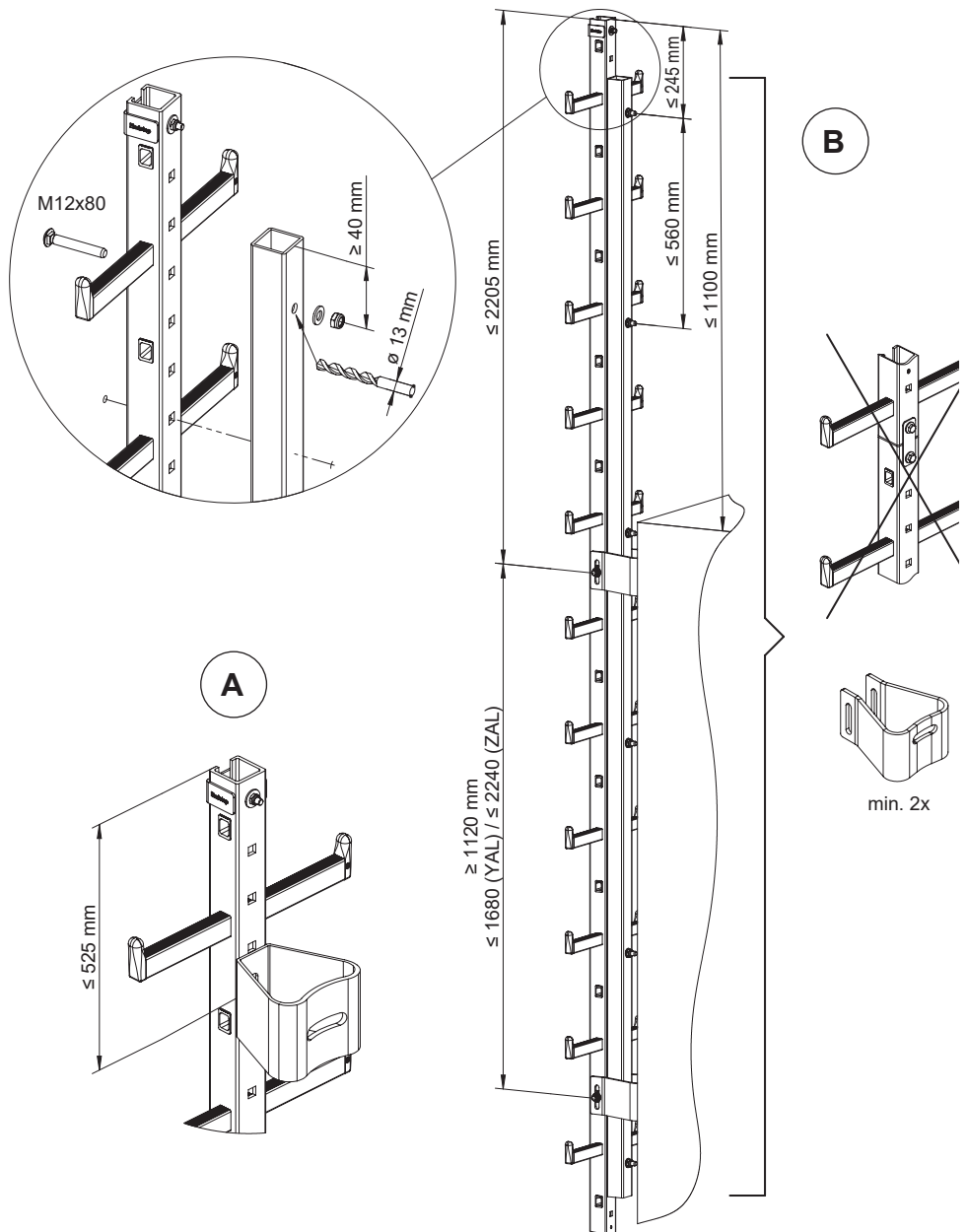

Fig. 2.3 - Upper ladder end without (A) and with (B) rail reinforcement

## 2.5.4 Folding and pivotable footrests

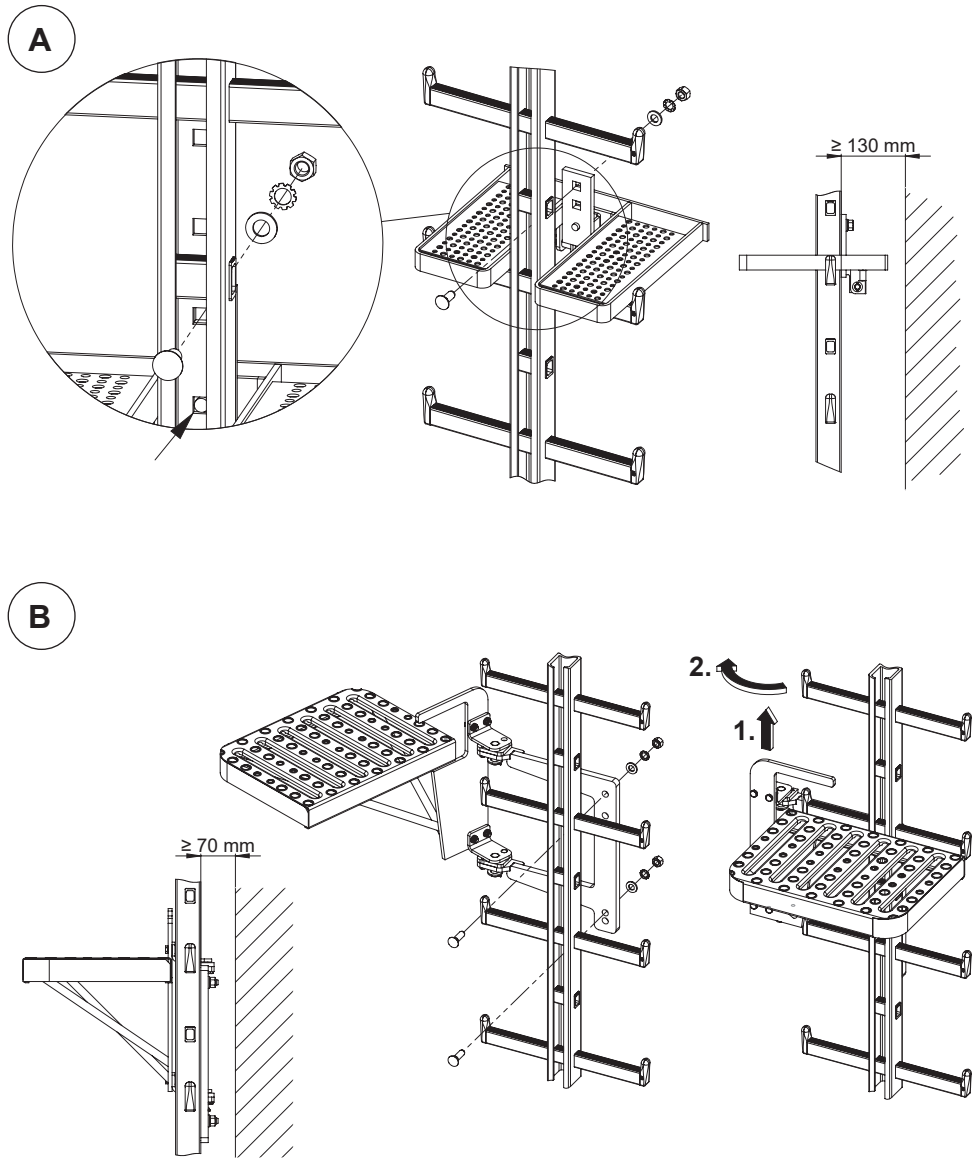
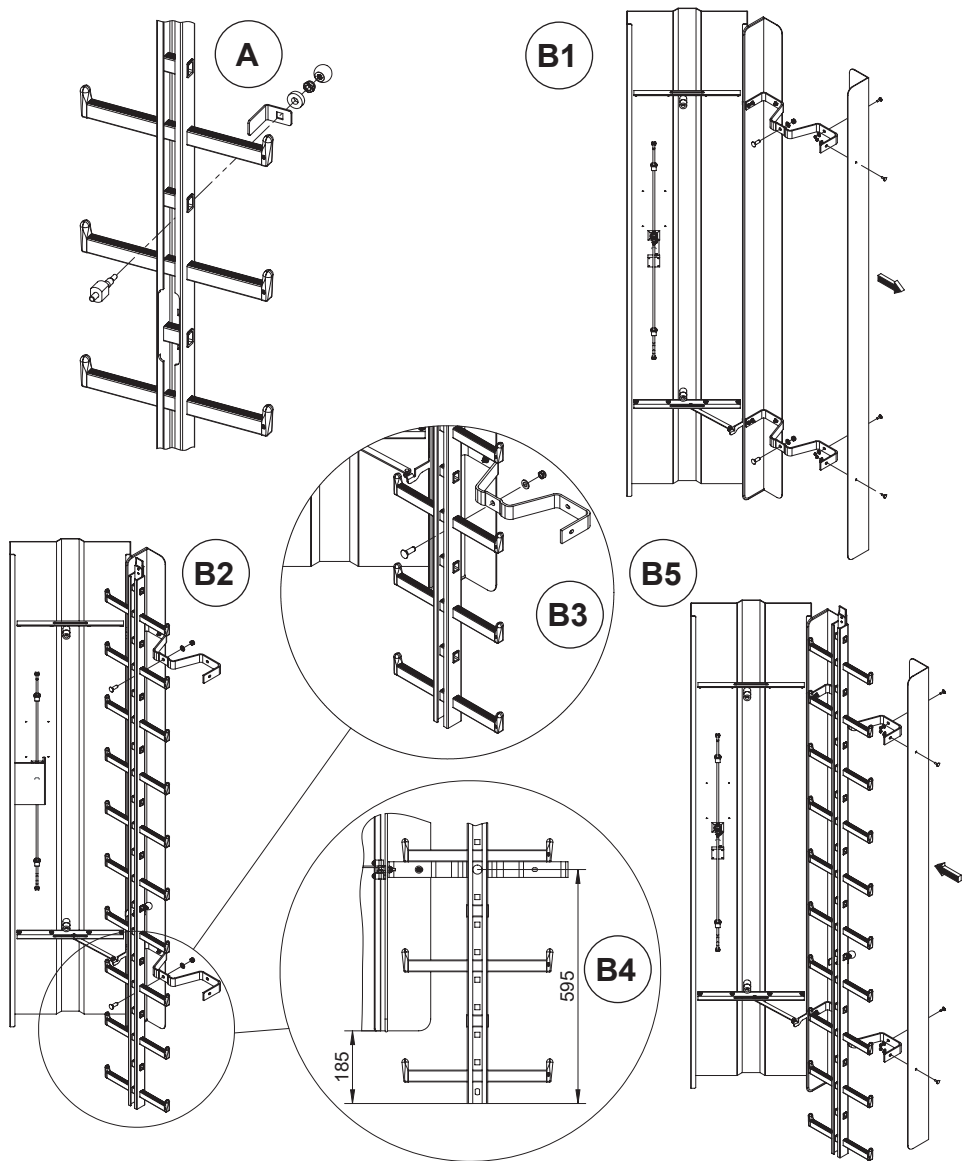

Fig. 2.4 - Folding footrest (A), pivotable footrest (B)

### 2.5.5 Pivotal aluminium cover plate (left/right hinged)



**Fig. 2.5 - Left hinged cover plate - Installing:**

- A: Mounting the end stop
- B1: Removing the side panel
- B2, B3, B4: Installing the cover plate, distances
- B5: Mounting the side panel

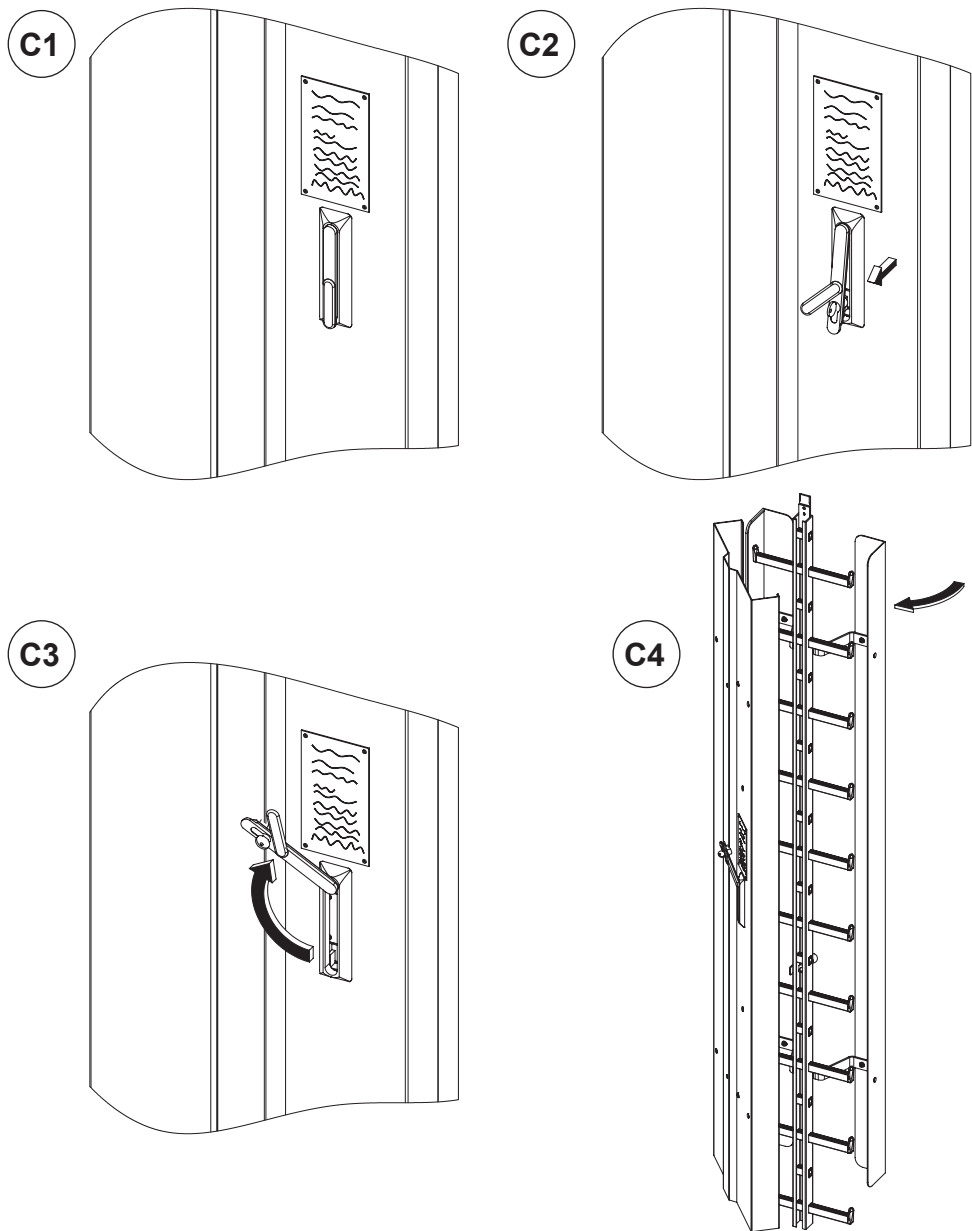

**Fig. 2.6** - Pivotal cover plate - opening: C1-C4: Unlocking and opening the door; closing and locking in reverse order



## 2.5.6 Cover plate for hooking, with handles

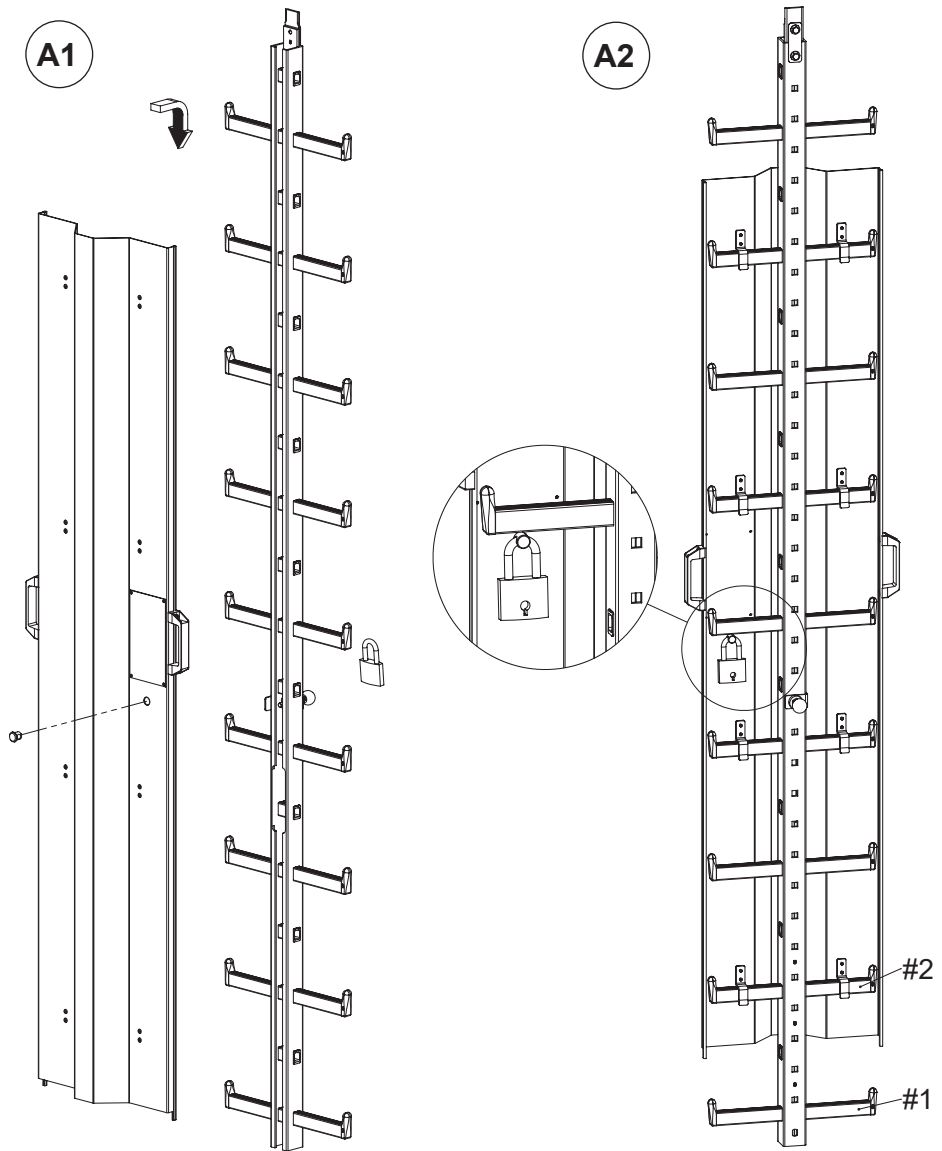

Fig. 2.7 - Cover plate for hooking, with handles: A1: Hooking the cover plate  
A2: Locking the cover plate

## 2.5.7 Exit section

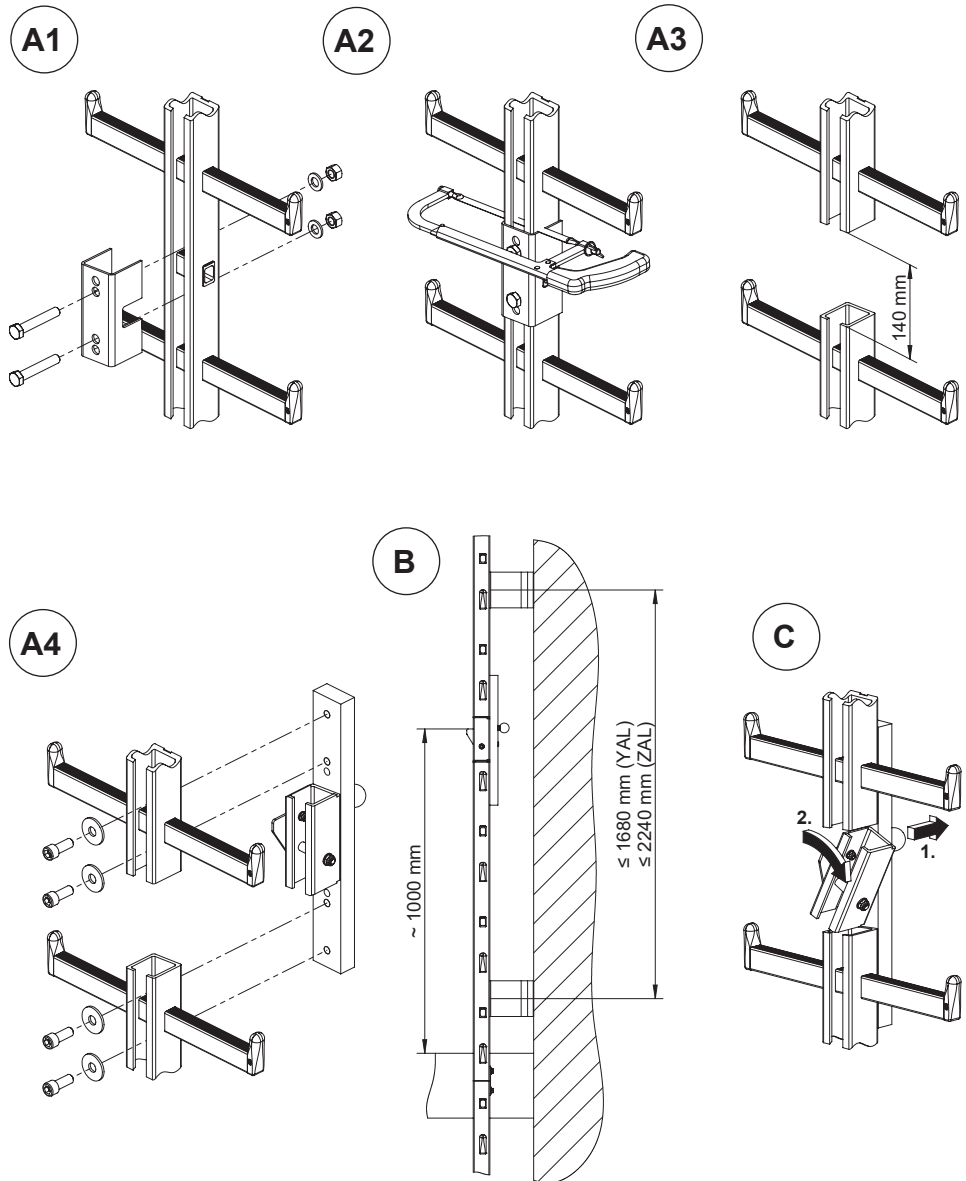

Fig. 2.8 - Exit section: mounting (A1...4), dimensions (B) and operation (C)

## 2.5.8 Rotary exit section

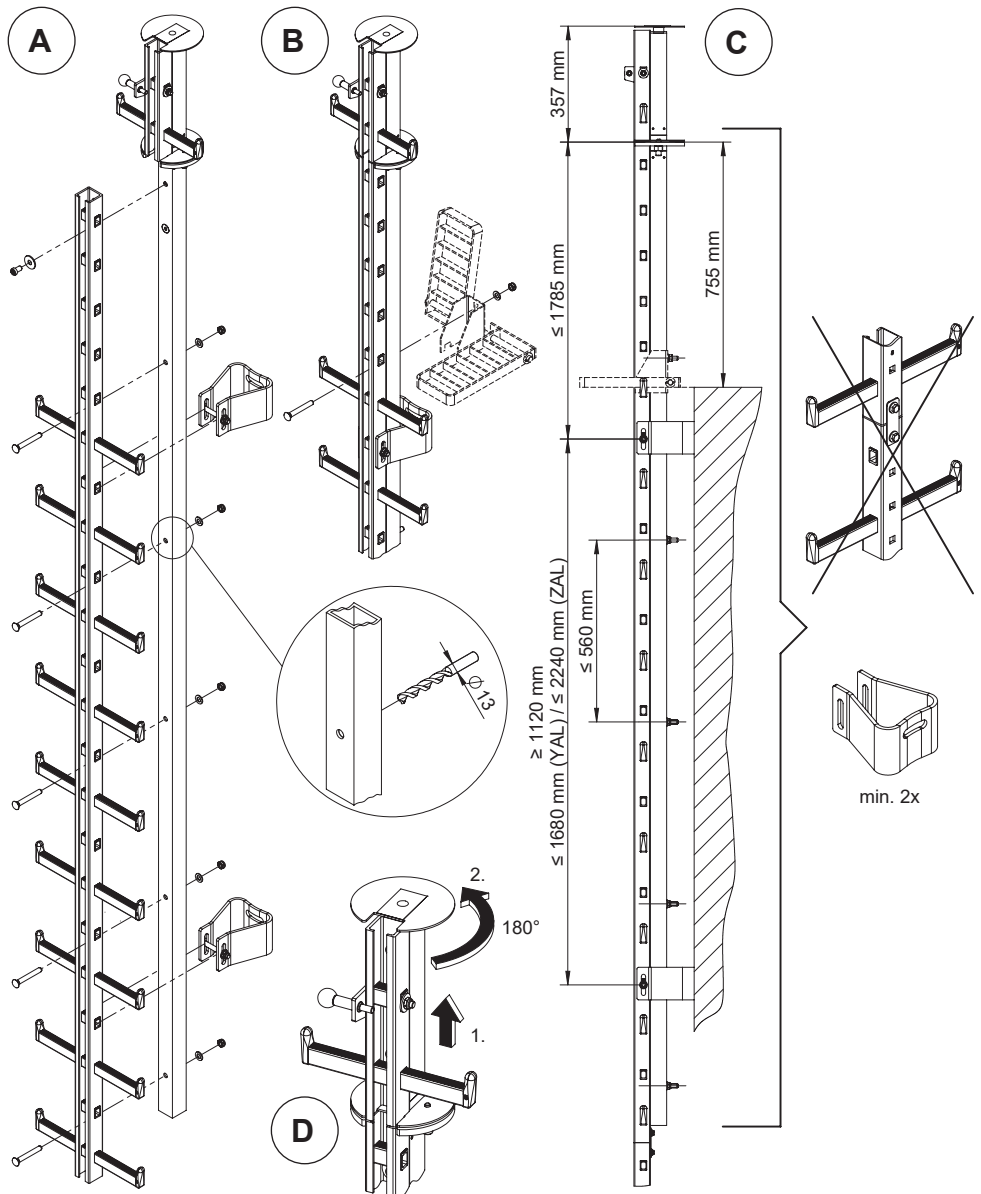
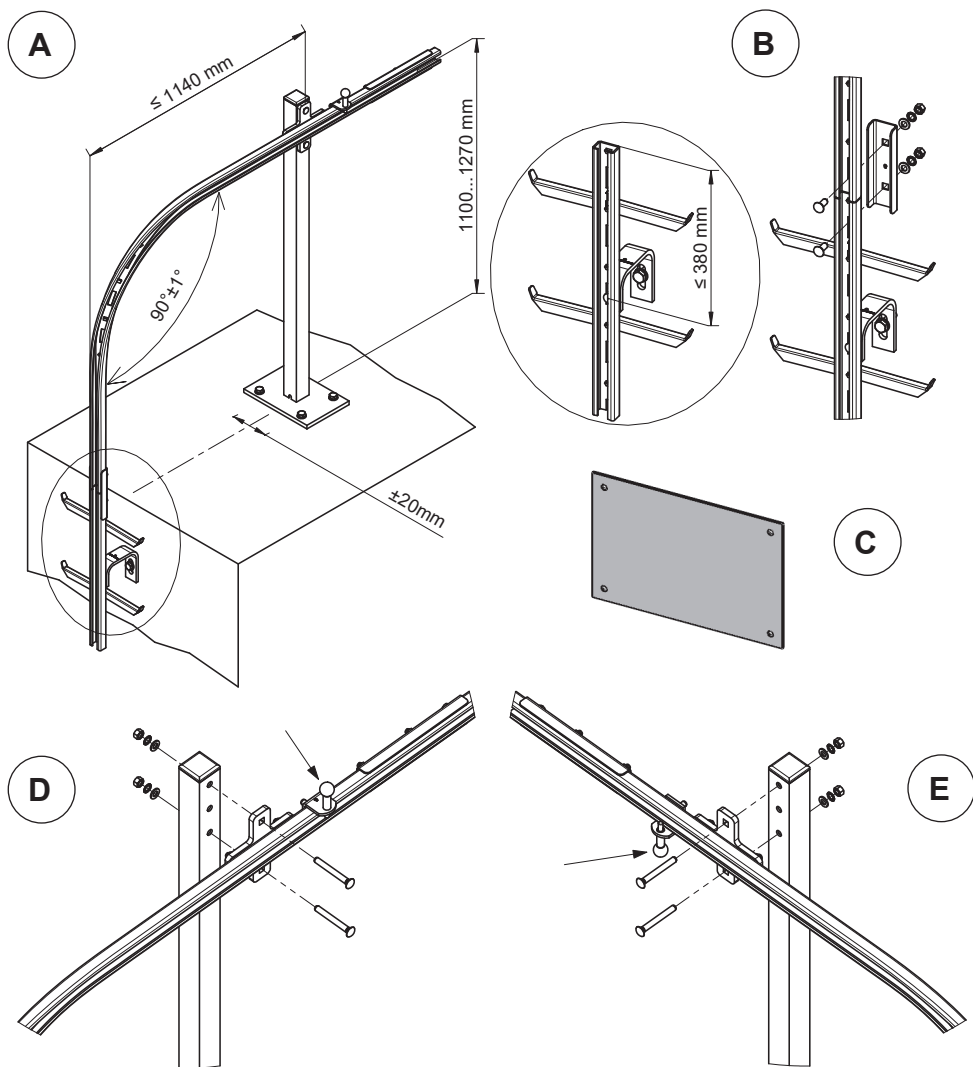

Fig. 2.9 - Assembly rotary exit section (A), assembly footrest (B) - optional, dimensions (C) and operation (D)

## 2.5.9 Twisted change over rail



**Fig. 2.10** - Twisted change over rail: A: Dimensions (exit right)  
 B: Assembly coupling  
 C: ID plate to be fixed next access  
 D: Assembly exit right (end stop upwards)  
 E: Assembly exit left (end stop downwards)

2.5.10 Pivot roof exit left/right

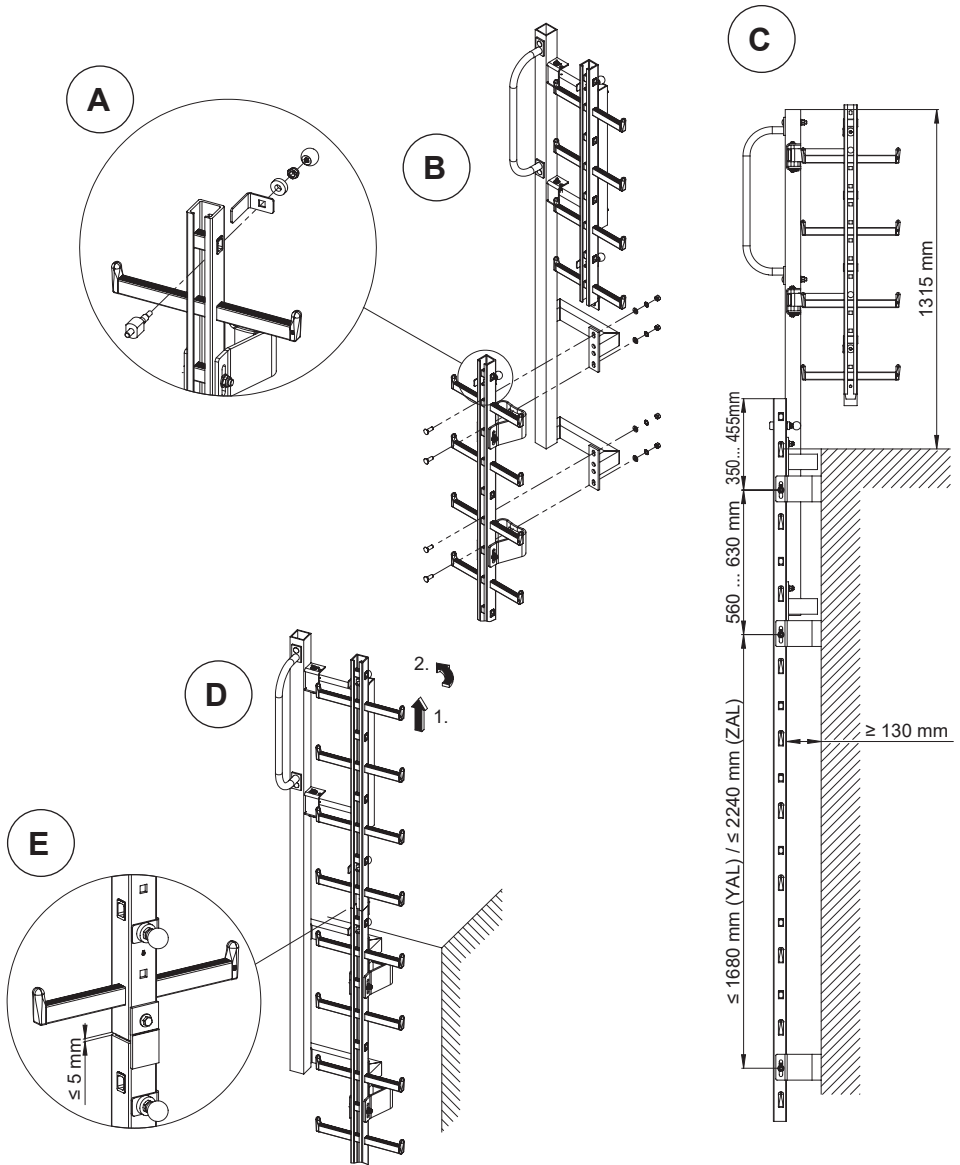

Fig. 2.11 - Pivot roof exit "left":

A: Assembly end stop  
 B: Assembly roof exit  
 C: Dimensions

D: Operation  
 E: Maximum gap in locked mode

2.5.11 Turntable with 4 fixation brackets

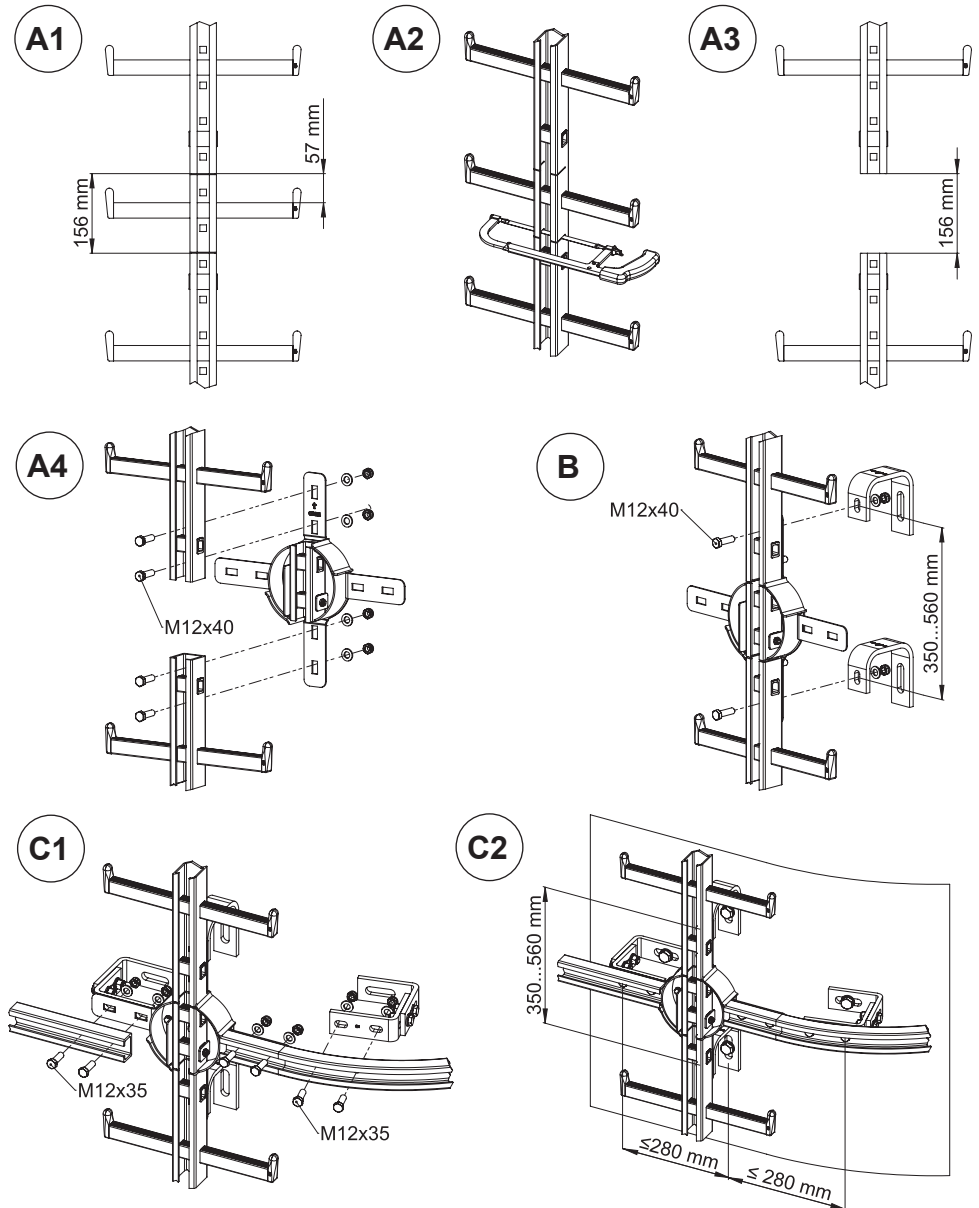
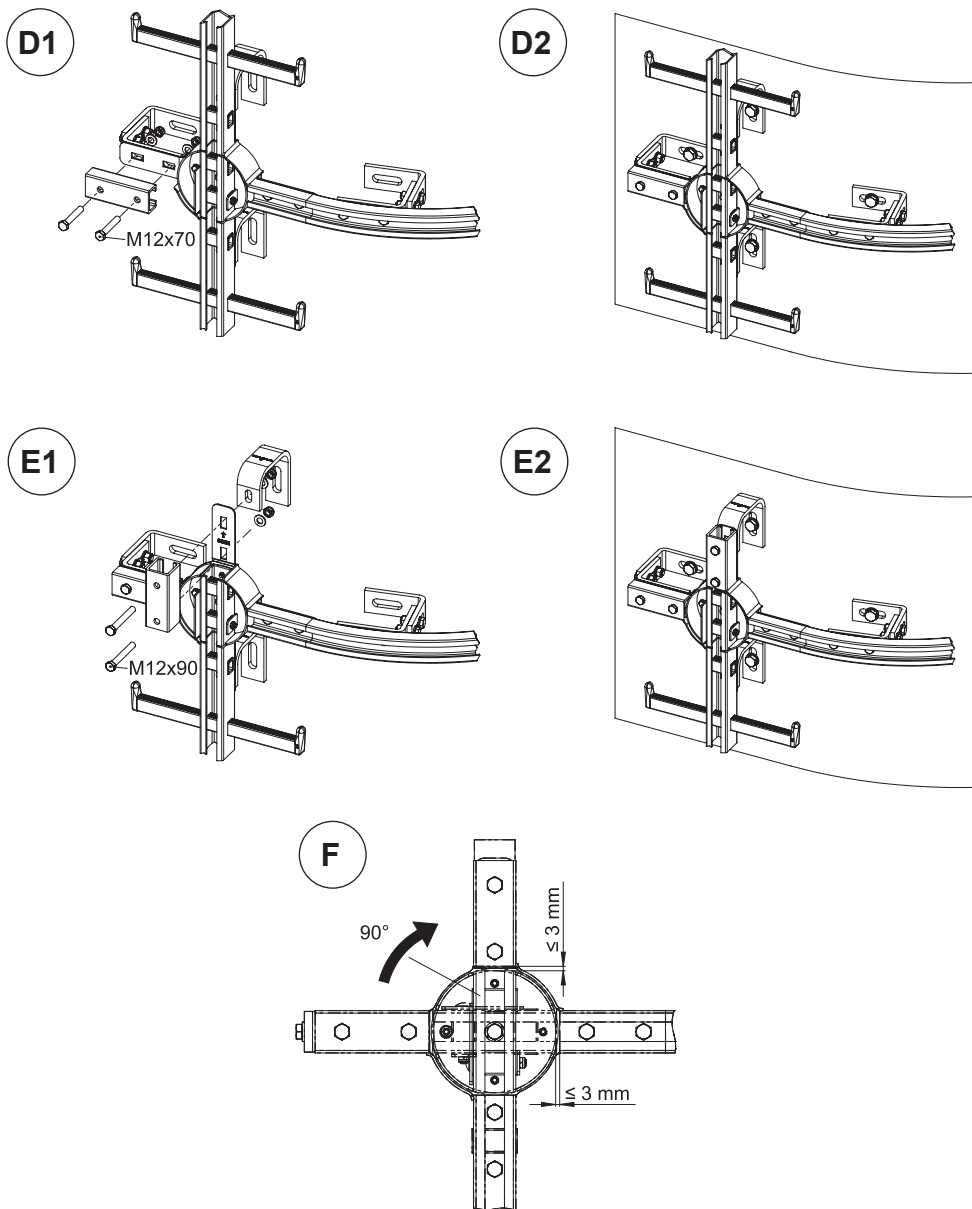

Fig. 2.12 - Turntable with 4 brackets: A1-A4: Assembly turntable  
 B: Dimensions and assembly of vertical brackets  
 C1-C2: Installation with 4 connections



**Fig. 2.13 - Turntable with 4 brackets - options:** D1-D2: Installation with 3 connections (1 stop profile)  
 E1-E2: Installation with 2 connections (2 stop profiles)  
 F: Operation and gap dimensions

2.5.12 Turntable with holder

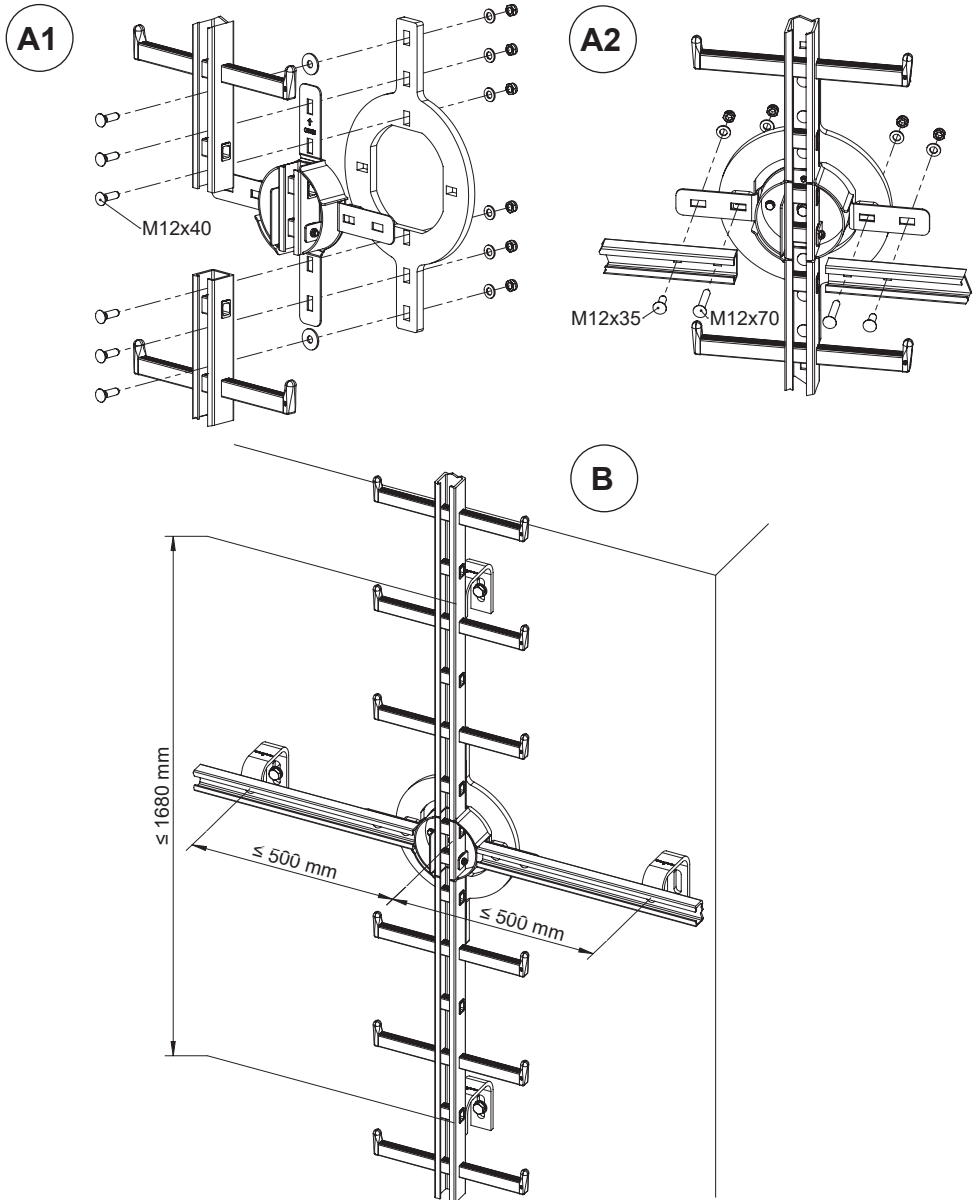

Fig. 2.14 - Turntable with holder: A1-A2: Assembly turntable with holder  
B: Bracket distances



### 2.5.13 Ho-Ver turntable

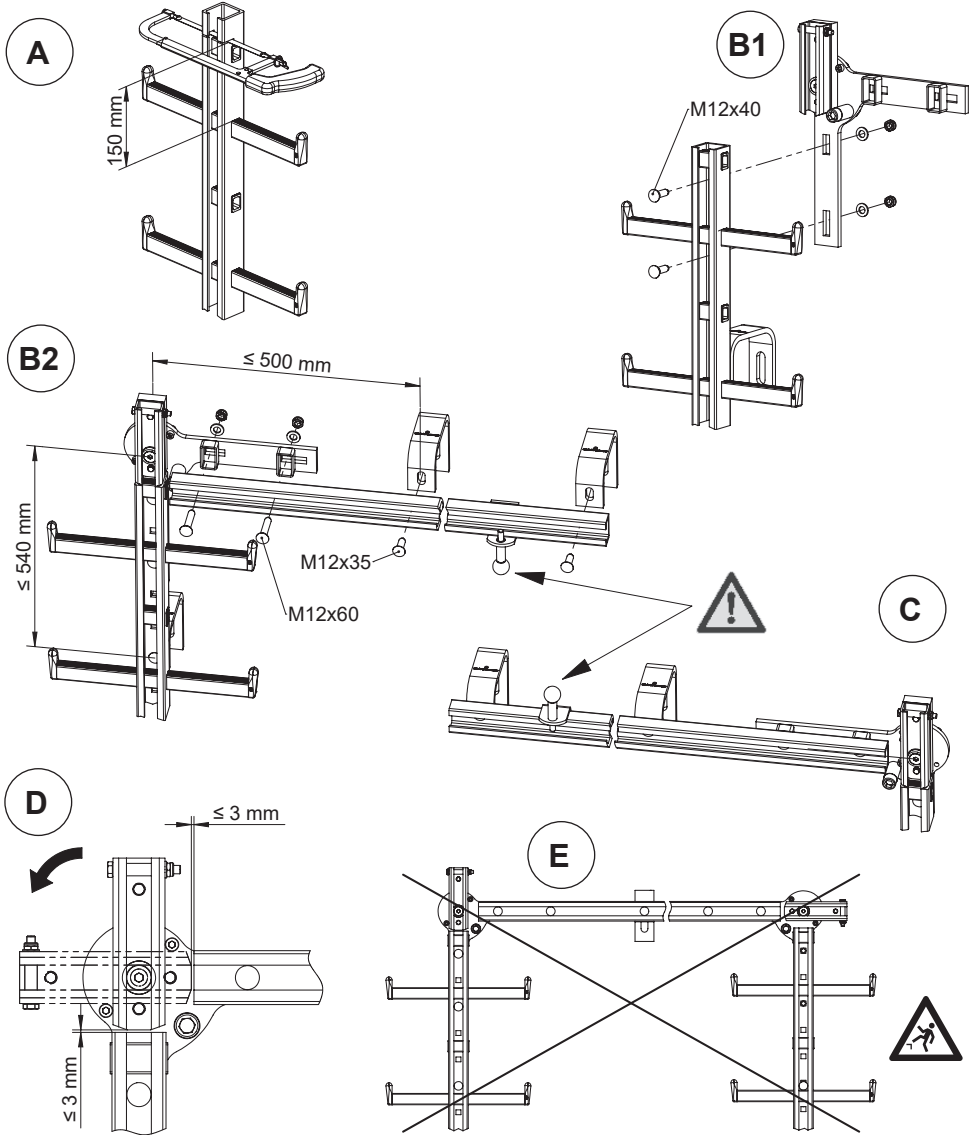
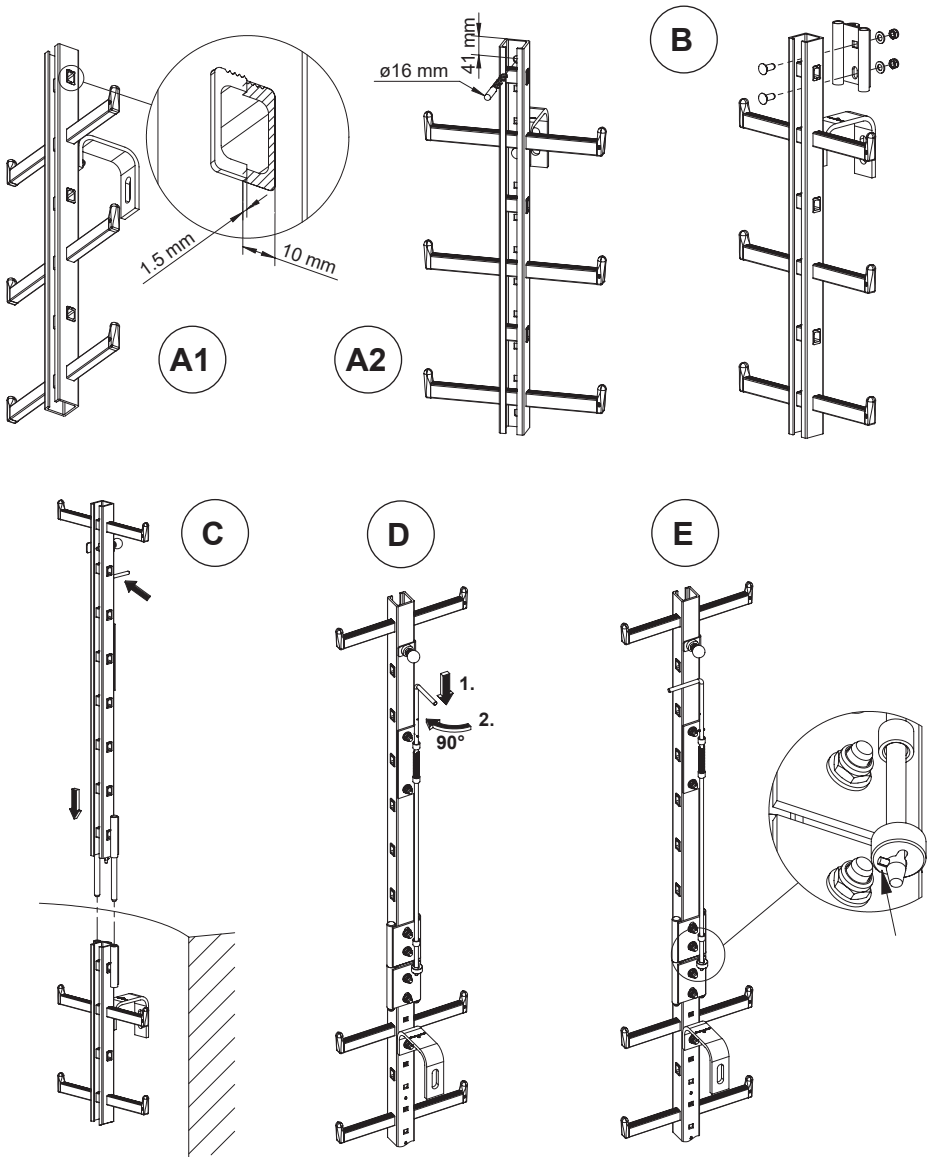

Fig. 2.15 - Ho-Ver turntable:

- A: Shortening the ladder
- B1, B2: Assembly and dimensions, rightward version - **end stop downwards**
- C: Leftward version - **end stop upwards**
- D: Operation and gap dimensions
- E: Forbidden assembly

## 2.5.14 Shaft entering device



**Fig. 2.16 - Assembly shaft entering device:** A1/A2: Machining (A1: Abrading; A2: Drilling)  
 B: Assembly coupling  
 C: Insert shaft entering device  
 D/E: Locking

## 2.5.15 Insertion ladder for hooking from below

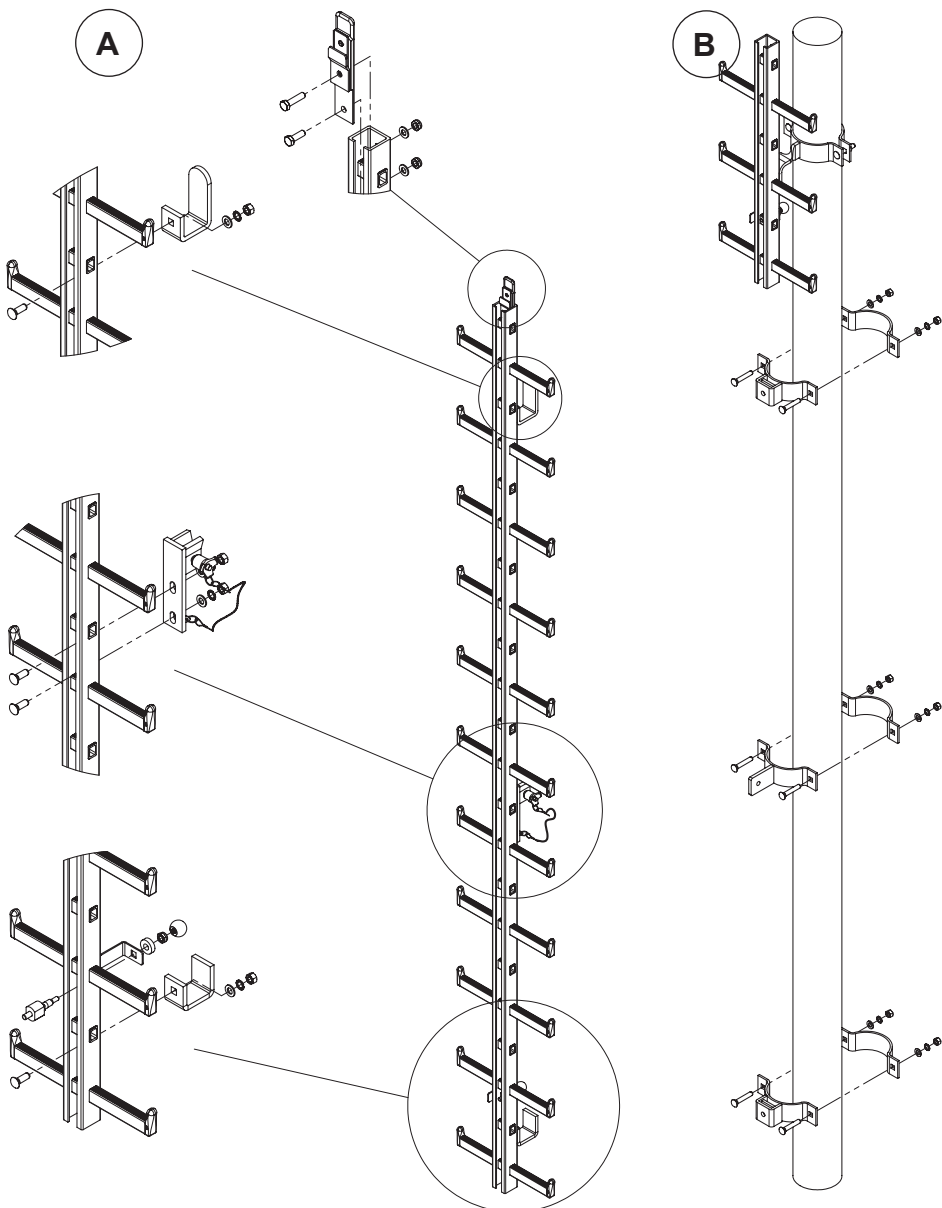

Fig. 2.17 - Assembly insertion ladder:

- A: Assembly brackets
- B: Assembly clamps

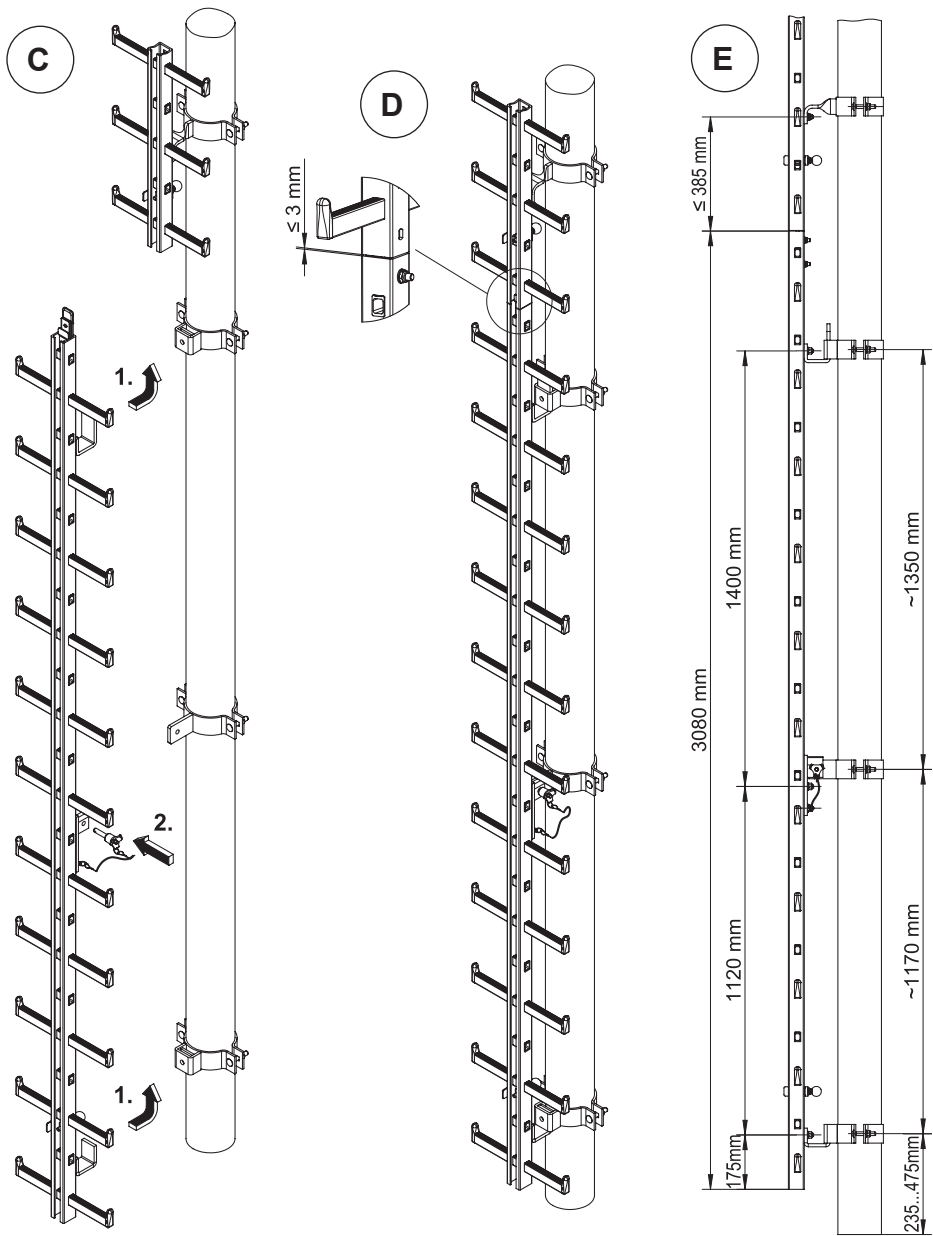

Fig. 2.18 - Assembly insertion ladder:

- C: Mounting the ladder
- D: Ready for use; maximum gap
- E: Dimensions

2.5.16 Insertion ladder for hooking in from top

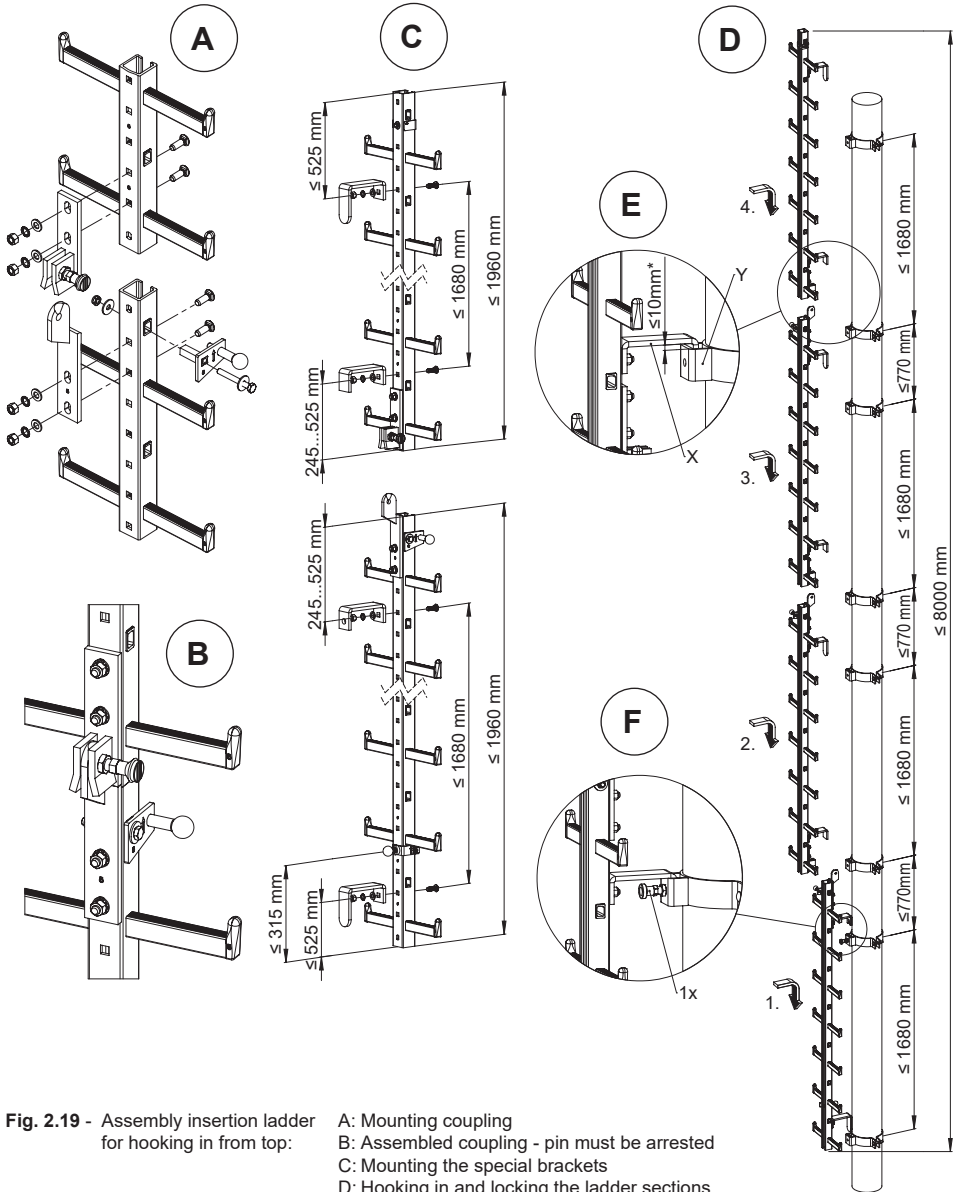
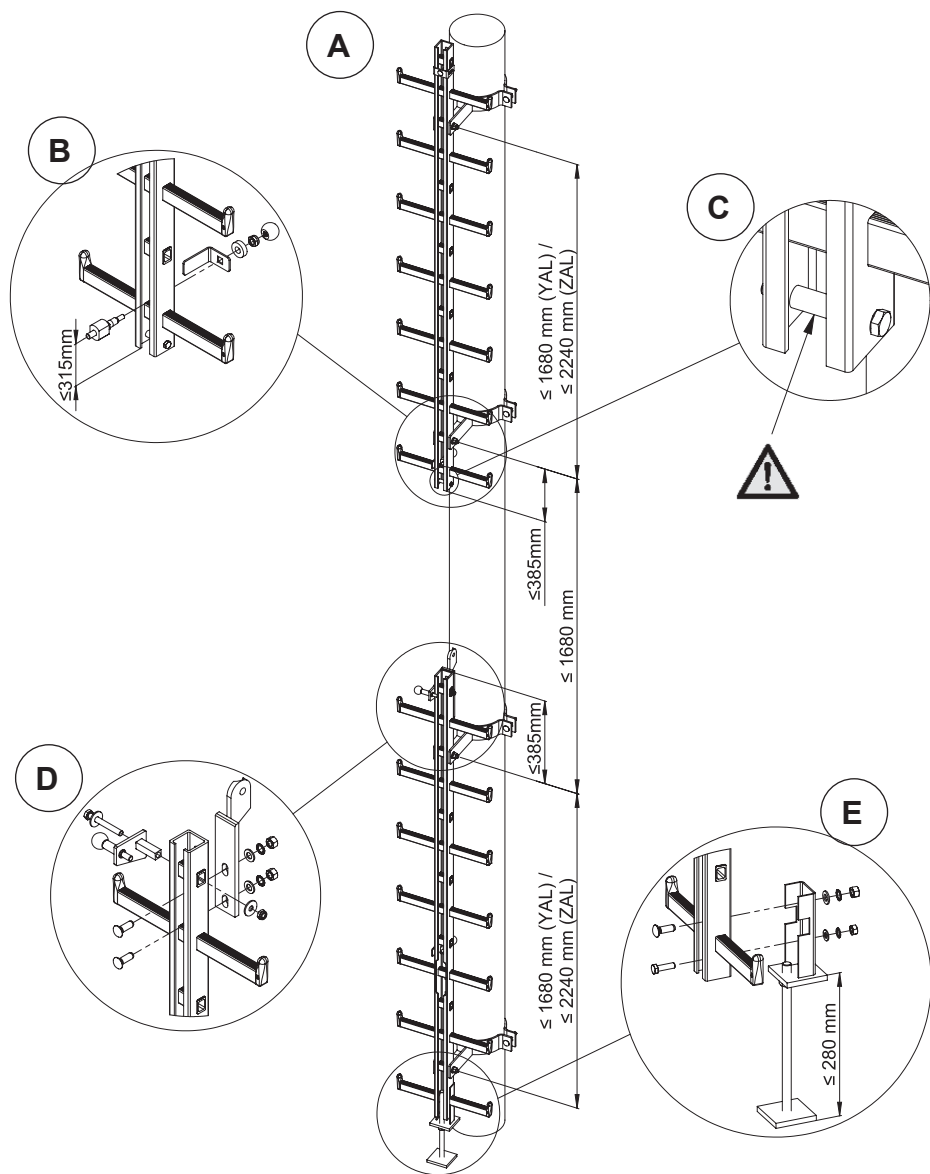

Fig. 2.19 - Assembly insertion ladder for hooking in from top:

- A: Mounting coupling
- B: Assembled coupling - pin must be arrested
- C: Mounting the special brackets
- D: Hooking in and locking the ladder sections
- E: Max. bracket gaps\*
- F: Arrested locking pin in the top bracket of 1st section

\* Note: At least 2 brackets (X) must be seated on the substructure fixations (Y) - without gap!

## 2.5.17 Movable ladder section



**Fig. 2.20** - Assembly movable ladder section:

- A: Fixation dimensions
- B: End stop
- C: Guiding pin (pre-assembled)

- D: Lower coupling part and end stop
- E: Ladder fixation for bottom

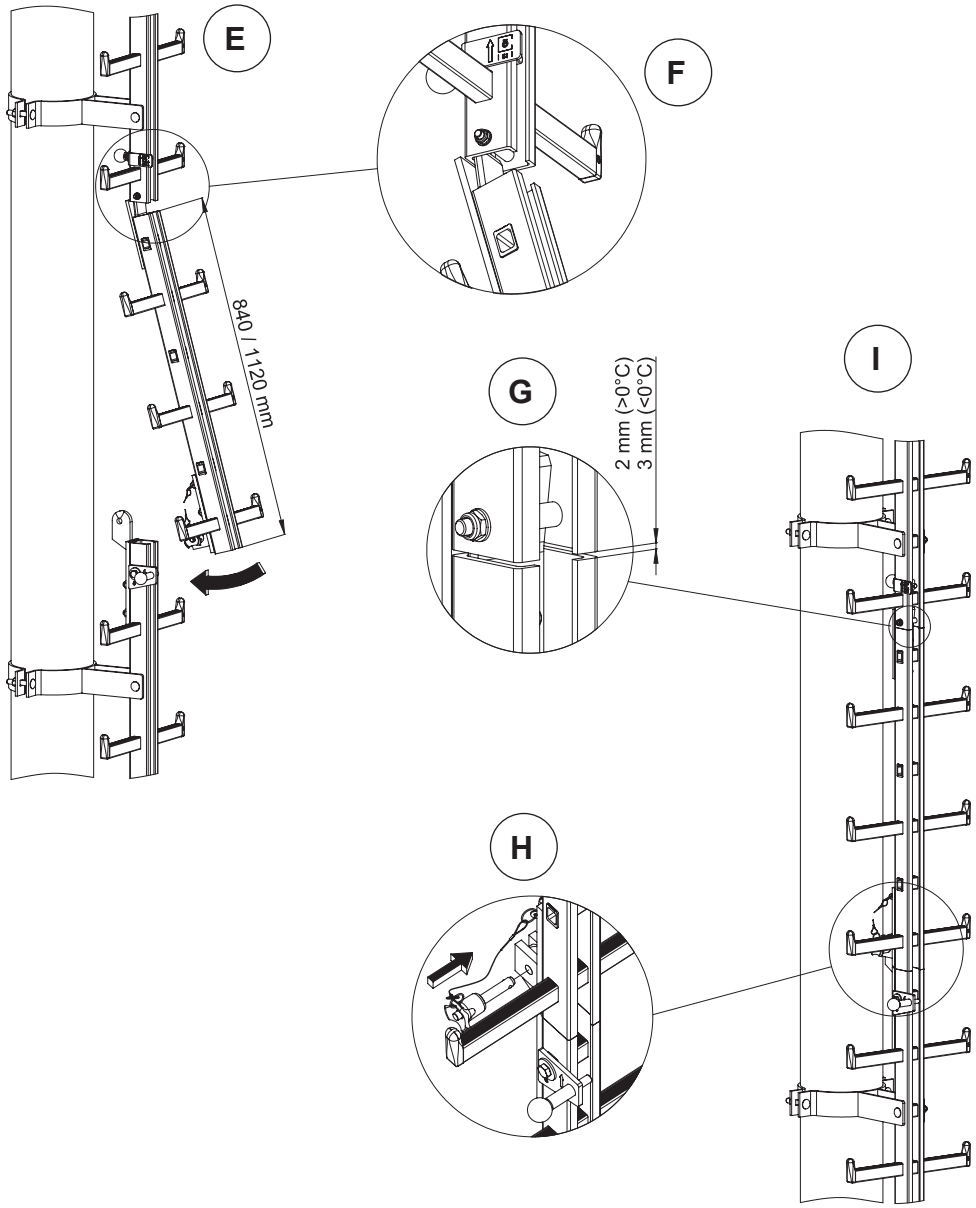

**Fig. 2.21** - Use of movable ladder section:

E/F: Insert the ladder  
 G: Recommended gaps

H: Insert the locking pin  
 I: Ladder ready for use

# 3 USE

Please also note section “2.2 Pre-use Checks”.

## 3.1 Foreseeable misuse

Every user must use a separate fall arrester! Only together with the Söll GlideLoc fall arrest system CE-certified fall arresters approved by the Manufacturer must be used.



**Danger!**

**Don't use the fall arrest system without an approved fall arrester. Please be aware that not complying with the recommendations of this manual may expose you or other users of this fall arrest system to serious risks of fall from heights and consequently to bodily injuries or even death.**

Further information in terms of avoiding misuse of the Söll GlideLoc fall arrest system please find in the user manual of the respective fall arrester.

## 3.2 Using the fall arrest system

The correct usage of the Söll GlideLoc fall arrest system is described in the user manual of the fall arresters.



**Danger!**

**Don't use the fall arrest system unless you have read and understood the fall arrester user manual.**



**Danger!**

**Don't disconnect from the fall arrest system if there is a risk of fall or unless you are otherwise secured against fall!**

## 3.3 Emergency procedures

It is essential that the operator of the Söll GlideLoc fall arrest system has an emergency rescue plan in place, which takes into account all possible emergencies that may occur while using the fall arrest system and which enables an immediate rescue of the user in case of a fall from height.



# 4 AFTER-USE INFORMATION AND MAINTENANCE

## 4.1 Cleaning

Basic care of all Honeywell Fall Protection equipment will prolong the life of the unit or system and will contribute to the performance of its vital safety function. Periodically clean system components to remove any dirt, paint, corrosives, contaminants, or other materials that may have accumulated.

It is recommended that soapsuds are used for cleaning. Don't use aggressive chemicals such as alcohol, acids or alkalis for cleaning!

## 4.2 Inspection

The Söll GlideLoc fall arrest system should be inspected regularly as required, but the system must be inspected at least once **every 12 months**. Abnormal environmental conditions (dirt, dust, chemical impacts, temperature, UV radiation and other) can require more frequent maintenance intervals. Please ask the customer service person (SCS, see section "1 Introduction, Contact) responsible for your area for advice.

Always ensure Manufacturer's instructions and statutory regulations are taken into account when inspecting.



### Warning!

**Inspections may only be carried out by the manufacturer or by its authorized person or body.**

**The authorization can be acquired through a training and regular refreshers by the manufacturer.**

**The hereby received certificate is valid for 3 years and authorizes to conduct regular inspections of Söll systems.**



### Important!

**If the fall arrest system has not been used for a period longer than 1 year, it must be inspected before reusing it.**



### Danger!

**A defective fall arrest system or one which has been subjected to stress resulting from a fall shall no longer be used and must be removed from service. It may only be used again if an authorized person or body approves such use in writing.**



### Warning!

**An authorization for inspections does not include an authorization to carry out repairs. (Please see section "4.4 Repair")**

### **4.3 Acceptance and regular inspections**

Acceptance and regular inspections have to be carried out according to the check list in APPENDIX 1. Identified defects should be documented in the list of APPENDIX 2.

### **4.4 Repair**

Only the Manufacturer or a person appointed by the Manufacturer is allowed to carry out repairs.

Components with mechanical damage (e.g. resulting from a fall) must be replaced.

Only use original spare parts or the ones approved by the Manufacturer while carrying out repairs.

For further information on the availability and suitability of spare parts, please contact the customer service person responsible for your area. (see section "**1 Introduction**").

Carried out repairs should be documented in the list of APPENDIX 2.

# 5 MISCELLANEOUS

## 5.1 Identification

### a) Identification plate

The identification plate (fig. 5.1) at the access points contains the following information. **The presence of the identification plate is mandatory and it must not be removed.**  
**At each regular inspection the legibility must be checked.**

1. Manufacturer, vendor or importer
2. Type designation: Söll GlideLoc
3. Product description: Fall Protection system
4. Version (C-AL, C-A4, C-St, RC-AL)
5. Reference to place of batch number
6. Installation date
7. Installation number (labelled internally by the installer)
8. Next inspection date
9. Applicable standard and year / Technical specification: EN 353-1:2014+A1:2017
10. Mark and identification number of the monitoring notified body of the fall protection system: CE 0158, DEKRA Testing and Certification GmbH
11. Technical Regulation of the Customs Union
12. Conformity marking of the Eurasian Customs Union
13. Pictogram advising the operator to read the instructions
14. Pictogram advising the operator to wear fall protection equipment
15. Note: Only use with harness EN 361 and Söll fall arrester EN 353-1 for use in Söll GlideLoc systems (Please note: A combination with components or elements of other manufacturers is not warranted by Honeywell Fall Protection Deutschland GmbH & Co. KG).

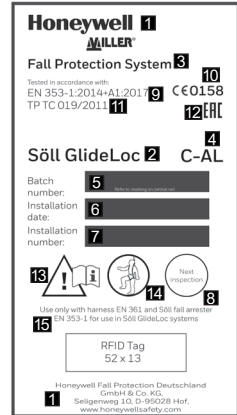

Fig. 5.1 - Identification plate

## 5.2 Notified Body

The system has been certified by EC-type test:

DEKRA Testing and Certification GmbH, Dinnendahlstraße 9, D-44809 Bochum, Germany, CE 0158.

# APPENDIX 1: Approval and inspection check list for the Söll GlideLoc fall arrest system

The regular inspections must be carried out as needed (e.g. after non-use of more than one year or because of special/ abnormal environmental conditions) or at least every 12 months under consideration of the legal requirements, the terms of use and the operational conditions.



## Important!

**In case the dates between which the system has been used are more than a year apart, the system must be inspected by an authorized person or body before the intended next use as described above.**

The regular inspections are necessary as the safety of the user depends on the effectiveness and durability of the equipment.

## Tightening torques

We recommend the following torque forces for fastening the fixing screws:

Screw material	Galvanized steel, 8.8			Stainless steel		
Size	M10	M12	M16	M10	M12	M16
Torque	20Nm	25Nm	60Nm	25Nm	30Nm	65Nm

## Control activities

(Please cross out not applicable parts.)

## Check note

(Please cross)

YES NO

Each ladder section / guide rail section has been mounted with at least one fixing bracket.	<input type="checkbox"/>	<input type="checkbox"/>
The maximum mounting distance has not been exceeded. (see section "2.5 Installation instructions").	<input type="checkbox"/>	<input type="checkbox"/>
The maximum gap width of 7 mm at the time of approval or regular inspections has not been exceeded.	<input type="checkbox"/>	<input type="checkbox"/>
The distance between ground and upper side of the first rung (140 - 380 mm) has been maintained.	<input type="checkbox"/>	<input type="checkbox"/>
All bolt connections have been tightened and are secured against loosening.	<input type="checkbox"/>	<input type="checkbox"/>
The screw connections which have been pre-mounted at the plant were checked.	<input type="checkbox"/>	<input type="checkbox"/>
All access and exit points are equipped with end stops.	<input type="checkbox"/>	<input type="checkbox"/>
Ladder sections / guide rails with recesses are mounted only at the beginning of the climbing path (in areas with no risk of fall).	<input type="checkbox"/>	<input type="checkbox"/>
The fall arrester can only be inserted in the climbing path in the direction of application.	<input type="checkbox"/>	<input type="checkbox"/>
The tolerable ladder projections (with / without reinforcement) have been observed.	<input type="checkbox"/>	<input type="checkbox"/>

## Control activities

(Please cross out not applicable parts. out!)

## Check note

(Please cross)

	YES	NO
The central reinforcement has been screwed on the ladder / guide rail at a maximum distance of 560mm.	<input type="checkbox"/>	<input type="checkbox"/>
There is no connecting part in the reinforcement area.	<input type="checkbox"/>	<input type="checkbox"/>
The reinforcement ranges over the last 2 mounting elements which are mounted at a minimum distance of 1120 mm.	<input type="checkbox"/>	<input type="checkbox"/>
The footrests have been mounted in due form according to the applicable regulations and guidelines.	<input type="checkbox"/>	<input type="checkbox"/>
Type plates have been mounted at each access.	<input type="checkbox"/>	<input type="checkbox"/>
The system operator has at least two suitable, together with the Söll GlideLoc fall arrest system CE-certified – fall arresters on-site.	<input type="checkbox"/>	<input type="checkbox"/>
A test ascent / descent has taken place.	<input type="checkbox"/>	<input type="checkbox"/>
Only components provided by the Manufacturer have been used.	<input type="checkbox"/>	<input type="checkbox"/>
<b>Pivotable cover plate</b>		
The cover plate has been mounted according to the specifications.	<input type="checkbox"/>	<input type="checkbox"/>
The protective foil has been removed (not safety related).	<input type="checkbox"/>	<input type="checkbox"/>
The cover plate can be opened and closed effortlessly.	<input type="checkbox"/>	<input type="checkbox"/>
The locking mechanism is serviceable.	<input type="checkbox"/>	<input type="checkbox"/>
<b>Cover plate for hooking</b>		
The cover plate can be safely hinged.	<input type="checkbox"/>	<input type="checkbox"/>
The locking bolt in connection with the padlock prevents the unauthorized removal of the cover plate.	<input type="checkbox"/>	<input type="checkbox"/>
<b>Exit section</b>		
The locking bolt is serviceable and locks in place in the pivoting part.	<input type="checkbox"/>	<input type="checkbox"/>
The pivoting part can be moved smoothly.	<input type="checkbox"/>	<input type="checkbox"/>
The fall arrester can be inserted in/taken off from the pivoting part only upwards.	<input type="checkbox"/>	<input type="checkbox"/>
The bolts delivered by the Manufacturer have been used for the assembly.	<input type="checkbox"/>	<input type="checkbox"/>
<b>Rotary exit section</b>		
The rotary exit section is mounted with at least 2 fixing clamps (minimum distance of the clamps: 1120 mm).	<input type="checkbox"/>	<input type="checkbox"/>
The maximum distance between the lower end of the exit section and upper bracket (1785 mm) has not been exceeded. (see section "2.5.8 Rotary exit section")	<input type="checkbox"/>	<input type="checkbox"/>
The rotating part can be easily turned and locks in place in the final positions.	<input type="checkbox"/>	<input type="checkbox"/>
The end stop of the rotating part is serviceable.	<input type="checkbox"/>	<input type="checkbox"/>
A footrest is present and mounted according to the regulations.	<input type="checkbox"/>	<input type="checkbox"/>

## Control activities

(Please cross out not applicable parts.)

## Check note

(Please cross)

YES NO

### Twisted change-over rail

The twisted change-over rail is fixed on the roof at an appropriately sized attachment point (e.g. attachment part, part no. 17509) by using the attachment cross.

The maximum dimension of 1140 mm between the front edge of the twisted change-over rail and the attachment point has not been exceeded.

The maximum free ladder projection of 385 mm was not exceeded.

Twisted change-over rail is installed with angle  $90^\circ \pm 1^\circ$ .

Horizontal tolerance  $\pm 20$  mm is not exceeded.

The end stop is serviceable and has been mounted independently from the version of the twisted change-over rail, so that it prevents the fall arrester from being inserted incorrectly.

The twisted change-over rail **has not** been mounted combined with a Ho-Ver Turntable.

The additional instruction plate „Twisted change-over rail“ (part no. 19808) has been affixed.

### Pivot roof exit

The pivot roof exit has been mounted according to the requirements (maximum gap between fixed ladder and pivoting element 5 mm).

The distance between the upper two fixation brackets does not exceed 630 mm.

The pivoting part can be lifted and moved easily.

The pivoting part locks in place in the final positions.

End stops are mounted and serviceable at the fixed ladder section and at the pivoting element.

### Turntable

The turntable has been mounted with 4 mounting brackets or supported / mounted by means of a turntable holder.

The rotary part can be turned effortlessly (from the vertical position:  $90^\circ$  clockwise).

The fall arrester passes smoothly through the turntable.

The guide rails as well as the safety blanking sections are aligned to the turntable.

The turntable **has not** been mounted combined with a twisted change-over rail “left”.

In case the turntable is used with a Ho-Ver turntable, the fall arrester is in the vertical section always in the direction of application (safety pin of the fall arrester is on the right side).

## Control activities

(Please cross out not applicable parts.)

## Check note

(Please cross)

YES NO

### Ho-Ver turntable

The rotary turn section can be turned effortlessly.

The mounting brackets have been mounted at a maximum distance of 560mm from the turning point of the turn section.

The maximum gap width of 3 mm between the turn section and the guide rails has not been exceeded.

The Ho-Ver turntable **was not** mounted combined with a twisted change-over rail.

The fall arrester can not be inserted incorrectly in the horizontal rail section (End stops were fixed in the correct orientation).

### Insertion ladder to be hooked in from top

All insertion ladder sections are mounted with at least 2 mounting brackets.

The arresting bolt at the fixing element with locking device is serviceable, it locks independently when inserting the lowest ladder section and blocks the ladder section against unintended lifting.

The end stop below the bottom part of the coupling part is serviceable.

The coupling part is serviceable, it locks into place when the ladder sections are connected and connects them together.

The ladder sections were mounted without gaps and are aligned.

The ladder sections can be easily mounted and disconnected.

At least 2 brackets are seated on the substructure fixations - no gap! (see section "2.5.15 Insertion ladder for hooking in from top."

### Insertion ladder to be mounted from the bottom

The ladder section is hinged to the structure by means of 3 fixing brackets.

The ball locking bolt at the fixing element with locking device is serviceable and fixed to the insertion ladder section by means of a fixing wire rope.

The insertion coupling part (top) connects the ladder sections without offset.

The ladder section can be assembled / removed effortlessly.

### Shaft entry device

The upper element can be inserted effortlessly into the lower element.

The locking device is serviceable and prevents the upper element from being lifted unintentionally.

**Control activities**

(Please cross out not applicable parts.)

**Check note**

(Please cross)

YES NO

**Movable ladder section**

The maximum fixation distance of 1680 mm in the area of the movable ladder section has not been exceeded.

The gap above and below the movable ladder section has not been exceeded 3 mm.

The supplied ladder fixation for bottom has been mounted to avoid lowering of the lower ladder.

The ladder section above the movable ladder section which has the guiding pin on its lower end is mounted with at least 2 fixation brackets to the substructure.

At the bottom of the upper ladder an end stop has been mounted.

Below the coupling part of the lower ladder the end stop is fixed.

After mounting the movable ladder section the ball locking pin can be plugged in effortlessly.

The movable ladder section, the upper and the lower ladder are mounted aligned.



**Comments:**

---

---

---

---

**Acceptance of the climbing path:**

Approved

Not approved Reasons:

---

---

---

---

**Next inspection:**

After 1 year

As necessary:

---

Operator:

Site:

Name of inspector:

Company of inspector:

---

---

---

---

Place, date

Signature of inspector

Signature of operator

# APPENDIX 2: Inspections and repairs

Year of manufacture:		Type designations/standard:		
Date of purchase:		Serial number:		
Date of first use:				
Date	Reason for working on the system	Damage determined, repairs carried out and other important details	Name and signature of the inspector/repairer	Date of the next regular inspection

**Further remarks**

---

---

---

---

---

---

---

---

---

---

---

---

---

---

---

---

---

---

---

---

---

---

---

EN/ Notified body having carried out the EU test of type: /BG/ Нотифициран орган, който провежда ЕС изпитване на тип: /CS/ Oznámený orgán, který provedl EU test typu: /DA/ Godkendt organisme, der har udført EU-typeafprøvningen: /DE/ Zugelassene Stelle, welche die EU-Typprüfung durchgeföhrt hat: /EL/ **Κοινοποιημένος οργανισμός ο οποίος διενήργησε τη δοκιμή τύπου ΕΕ**: /ES/ Organismo notificado que ha realizado el examen UE de tipo: /ET/ Teavitatud asutus, mis tegi EL-tüübikatse: /FI/ Ilmoitettu järjestö, joka on suorittanut EU-tyyppitarkastuksen: /FR/ Organisme notifié ayant réalisé l'examen UE de Type: /HR/ Nadležno tijelo, koje je izvršilo EU tipsko testiranje: /HU/ A típus EU teszjtét elvégző kijelölt szervezet: /IT/ Organismo notificato che ha effettuato il controllo UE del Tipo: /LT/ Informuota institucija, atlikusi ES tipo testą: /LV/ Pilnvarotā iestāde, kas veikusi tipa ES pārbaudi: /NL/ Erkend organisme dat het EU type-onderzoek uitvoerde: /NO/ Notifisert organ som har utført EU-typeundersøkelse: /PL/ Jednostka notyfikowana zrealizowała badanie UE typu: /PT/ Organismo notificado tendo realizado o exame de tipo UE / RO/ Organismul notificat care a efectuat testarea UE de tip: /RU/ Уполномоченный орган, выполняющий испытание ЕС типа: /SK/ Notifikovaný orgán, ktorý vykonal skúšku typu EÚ: /SV/ Officiellt provningsorgan som utfört EU-kontrollen av Typ: /TR/ AB tip testini yürütmüş olan onaylı kuruluş:

DEKRA Testing and Certification (O158)  
Test laboratory for Component Safety  
Dinnendahlstr. 9 - 44809 Bochum  
GERMANY

EN/ Notified body involved in the monitoring of production (module C2): /BG/ Нотифициран орган, включен в мониторинга на производството (модул C2): /CS/ Oznámený orgán zapojený do sledování výroby (modul C2): /DA/ Bemyndiget organ involveret i overvågning af produktion (modul C2): /DE/ Benannte Stelle, die an der Überwachung der Produktion beteiligt ist (Modul C2): /EL/ **Κοινοποιημένος οργανισμός που συμμετέχει στην παρακολούθηση της παραγωγής (ενότητα C2)** /ES/ Organismo notificado involucrado en el monitoreo de producción (módulo C2): /ET/ Tootmist jälgiv teavitatud asutus (moodul C2): /FI/ Ilmoitettu taho, joka mukana laitteen valmistuksen valvonnassa (moduuli C2): /FR/ Organisme notifié intervenant dans le suivi de production (module C2): /HR/ Nadležno tijelo uključeno u nadzor proizvodnje (modul C2): /HU/ A termelés felügyelését biztosító szerv (D modul): /IT/ Organismo notificato coinvolto nel monitoraggio della produzione (modulo C2) /LT/ Notifikuotoji įstaiga, atliekanti gamybos stebėjimą (D modulis): /LV/ Pilnvarotā iestāde, kas iesaistīta ražošanas pārraudzībā (modulis C2): /NL/ Erkend organisme dat betrokken is bij het toezicht op de productie (module C2): /NO/ Notifisert organ involvert i overvåkning av produksjon (modul C2): /PL/ Jednostka notyfikowana zaangażowana w monitorowanie produkcji (modul C2): /PT/ Organismo notificado incluído para a monitorização da produção (módulo C2): /RO/ Organismul notificat responsabil cu monitorizarea producției (modulul C2): /RU/ Уполномоченный орган, занимающийся мониторингом производства (модуль C2): /SK/ Notifikovaný orgán zapojený do monitorovania výroby (modul C2): /SL/ Obveščeni organ, ki je vključen v nadzorovanje izdelovanja (modul C2): /SV/ Officiellt provningsorgan ansvarigt för produktionsövervakning av produktion (modul C2): /TR/ Üretim izleminde görev alan onaylı kuruluş (Modül C2)

DEKRA Testing and Certification (O158)  
Test laboratory for Component Safety  
Dinnendahlstr. 9 - 44809 Bochum  
GERMANY

**EN/** Honeywell Fall Protection hereby declares that this product is in compliance with the essential requirements and other relevant provisions of Regulation EU 2016/425 and all other EU directive requirements. The complete declaration of conformity can be found at: **/BG/** С настоящото Honeywell Fall Protection декларира, че този продукт съответства на основните изисквания и останалите съответни разпоредби на Регламент 2016/425 на ЕС и на всички останали изисквания на директивите на ЕС. Цялата декларация за съответствие е достъпна на: **/CS/** Honeywell Fall Protection tímto prohlašuje, že tento výrobek splňuje základní požadavky a další relevantní ustanovení Nařízení EU 2016/425 a všechny ostatní požadavky směrnice EU. Úplné prohlášení o shodě lze nalézt na: **/DA/** Honeywell Fall Protection erklærer hermed, at dette produkt stemmer overens med de væsentlige krav og andre relevante bestemmelser i Forordning EU 2016/425 og alle andre krav i EU-direktiver. Den fulde overensstemmelseserklæring kan findes på: **/DE/** Honeywell Fall Protection erklärt hiermit, dass dieses Produkt die wesentlichen Anforderungen und andere relevante Bestimmungen der Verordnung EU 2016/425 und weitere EU-Richtlinien erfüllt. Die vollständige Konformitätserklärung ist einsehbar unter **/EL/** Honeywell Fall Protection δηλώνει ότι το προϊόν αυτό συμμορφώνεται με τις βασικές απαιτήσεις και τις λοιπές σχετικές διατάξεις του ΚΑΝΟΝΙΣΜΟΣ ΕΕ 2016/425 και με όλες τις άλλες απαιτήσεις της Οδηγίας της ΕΕ. Η πλήρης δήλωση συμμόρφωσης βρίσκεται στον ιστότοπο: **/ES/** Por la presente, Honeywell Fall Protection declara que este producto cumple con los requisitos esenciales y con otras cláusulas relevantes de la Reglamento EU 2016/425 y con todos los demás requisitos de directivas de la UE. La declaración de conformidad completa se puede encontrar en: **/ET/** Käesolevaga deklareerib Honeywell Fall Protection, et see toode vastab ELi määruse EL 2016/425 ja kõikide muude ELi direktiivide põhinõuetele ja muudele asjakohastele nõuetele. Täieliku vastavusdeklaratsiooni võite leida saidilt **/FI/** Honeywell Fall Protection vakuuttaa täten, että tämä tuote täyttää Asetus EU 2016/425 sekä muiden EU-direktiivien olennaiset vaatimukset. Täydellinen vaatimustenmukaisuusvakuutus on osoitteessa: **/FR/** Honeywell Fall Protection déclare que ce produit est conforme aux critères essentiels et autres dispositions du Règlement UE 2016/425 et des autres directives européennes applicables. L'attestation complète de conformité est disponible à l'adresse **/HR/** Honeywell Fall Protection izjavlja da proizvod ispunjava zahtjeve i druge odgovarajuće odredbe Uredba EU 2016/425 i ostalih EU-Direktiva. Potpunu Izjavu o suglasnosti potražite na **/HU/** A Honeywell Fall Protection nyilatkozta, hogy a termék megfelel az érvényes követelményeknek és a 2016/425 sz. EU Rendelet előírásainak és a többi EU-s irányelvet előírásainak. A teljes megfeleléségi nyilatkozatot megtekintheti a weboldalon.

<https://doc.honeywellsafety.com>

**/IT/** Honeywell Fall Protection dichiara che il presente prodotto è conforme ai requisiti essenziali e ad altre disposizioni applicabili dal Regolamento UE 2016/425 e di tutte le altre direttive UE. La dichiarazione di conformità completa è disponibile all'indirizzo: **/LT/** Šiuo dokumentu „Honeywell Fall Protection“ pareiškia, kad šis produktas atitinka 2016/425 ES reglamentas ir kitų ES direktyvų atitikimus esminius reikalavimus ir kitas susijusias nuostatas. Visą atitikties deklaraciją galite rasti: adresu **/LV/** Uzņēmums Honeywell Fall Protection ar šo paziņo, ka šis produkts atbilst Regulas (ES) 2016/425 pamatprasībām un saistītajiem noteikumiem, kā arī visu citu ES direktyvu prasībām. Pilna atbilstības deklarācija ir pieejama vietnē: **/NL/** Honeywell Fall Protection verklaart hierbij dat dit product voldoet aan de essentiële vereisten en andere relevante bepalingen van Verordening EU 2016/425 en alle andere vereisten van de EU-Reglementeringen. De volledige conformiteitsverklaring kunt u vinden op: **/NO/** Honeywell Fall Protection erklærer herved at dette produktet er i samsvar med grunnleggende og andre relevante krav i henhold til forordning EU 2016/425 og alle andre krav i EU-direktiver. Den fullstendige overholdelseserklæringen finner du på: **/PL/** Firma Honeywell Fall Protection niniejszym deklaruje, że ten produkt jest zgodny z podstawowymi wymaganiami i zaleceniami określonymi w rozporządzeniu EU 2016/425 oraz innych dyrektywach UE. Pełna treść Deklaracji zgodności jest dostępna w witrynie: **/PT/** A Honeywell Fall Protection declara pelo presente que este produto está de acordo com os requisitos essenciais, bem como outras disposições relevantes, da Regulamento EU 2016/425 e todos os outros requisitos de diretivas da União Europeia. O texto completo da Declaração de Conformidade encontra-se em: **/RO/** Honeywell Fall Protection declară prin prezentul că acest produs respectă cerințele esențiale și alte prevederi relevante ale Regulamentului UE 2016/425 și ale tuturor celorlalte cerințe ale directivelor UE. Declarația completă de conformitate poate fi găsită la: **/RU/** Корпорация Honeywell Fall Protection настоящим заявляет, что данный продукт соответствует основным требованиям и другим соответствующим положениям регламента EU 2016/425 и прочих требованиям директивы ЕС. Полную декларацию соответствия можно найти здесь: **/SK/** Spoločnosť Honeywell Fall Protection týmto vyhlasuje, že tento výrobok je v súlade so základnými požiadavkami a ďalšími príslušnými ustanoveniami nariadenia EÚ 2016/425 a všetkými ostatnými požiadavkami smernice EÚ. Úplné vyhlásenie o zhode možno nájsť na adrese: **/SL/** Honeywell Fall Protection s tem izjavlja, da je ta izdelek skladen s ključnimi zahtevami in drugimi relevantnimi določili Uredbe EU 2016/425 in vsemi drugimi zahtevami direktive EU. Celotno izjavo o skladnosti lahko najdete na: **/SV/** Härmed förklarar Honeywell Fall Protection att denna produkt i alla väsentliga avseenden uppfyller de krav och föreskrifter som uppställts enligt Förordning EU 2016/425 och andra EG-direktiv. En komplett försäkran om överensstämmelse finns på: **/TR/** Honeywell Düşme Önleyici Tertibat işbu belgede bu ürünün AB Yönetmeliği 2016/425'in temel gerekliliklerine ve diğer ilgili hükümlerine ve diğer tüm AB yönetgesi gerekliliklerine uygun olduğunu beyan eder. Tam uygunluk beyanı adresinde mevcuttur.





SEN 99 |B| 09/2022  
Technical modifications reserved!  
© 2022 Honeywell International Inc.

**Honeywell Fall Protection  
Deutschland GmbH & Co. KG**

Seligenweg 10  
D-95028 Hof

Phone +49 (0) 9281 83 02 0

Fax +49 (0) 9281 36 26

[scs-hof@honeywell.com](mailto:scs-hof@honeywell.com)

[www.honeywell.com](http://www.honeywell.com)

