

Honeywell

IH40

UHF RFID Reader



User Guide

Disclaimer

Honeywell International Inc. (“HII”) reserves the right to make changes in specifications and other information contained in this document without prior notice, and the reader should in all cases consult HII to determine whether any such changes have been made. HII makes no representation or warranties regarding the information provided in this publication.

HII shall not be liable for technical or editorial errors or omissions contained herein; nor for incidental or consequential damages resulting from the furnishing, performance, or use of this material. HII disclaims all responsibility for the selection and use of software and/or hardware to achieve intended results.

This document contains proprietary information that is protected by copyright. All rights are reserved. No part of this document may be photocopied, reproduced, or translated into another language without the prior written consent of HII.

Copyright © 2023 Honeywell Group of Companies. All rights reserved.

Web Address: sps.honeywell.com

Trademarks

Android is a trademark of Google LLC.

Bluetooth trademarks are owned by Bluetooth SIG, Inc., U.S.A. and licensed to Honeywell.

Other product names or marks mentioned in this document may be trademarks or registered trademarks of other companies and are the property of their respective owners.

Patents

For patent information, refer to www.hsmpats.com.

TABLE OF CONTENTS

Customer Support	iii
Technical Assistance	iii
Product Service and Repair	iii
Limited Warranty	iii
Chapter 1 - Introduction	1
IH40 Features	1
Battery Installation	2
Charging	4
Docking Station Charge	4
Installing/Removing Device Bracket and Attaching Device	6
Install Device	6
Remove the Device	8
Reading RFID Tags	9
MODE Button and Status Indicators	10
Chapter 2 - HonRFID Mobile Application for Android.....	11
Overview.....	11
Using the HonRFID Mobile Application for Android	11
Download the App	11
Basic Operation	12
Home Screen	12
Connect	13

Connect by USB.....	13
Connect by Bluetooth	14
Auto Connect by Bluetooth.....	14
QR Code Connect	14
NFC Connect	15
Scan	15
Edit Tag.....	16
Write Tag.....	16
Lock Tag	17
Locate Tag	17
Settings	19
Common Settings	19
About	21
Update Firmware	21
About Software Updates.....	21
Update BLE Firmware	21
Update RFID Firmware.....	22
Update USB Firmware.....	22

Chapter 3 - Maintenance and Troubleshooting 25

Maintenance.....	25
Troubleshooting	25

Customer Support

Technical Assistance

Go to honeywell.com/PSStechnicalsupport to search our knowledge base for a solution or to log into the Technical Support portal.

Product Service and Repair

Honeywell International Inc. provides service for all of its products through service centers throughout the world. Go to sps.honeywell.com and select Support to find a service center near you or to get a Return Material Authorization number (RMA #) before returning a product.

Limited Warranty

For warranty information, go to sps.honeywell.com and select **Support > Productivity > Warranties**.

INTRODUCTION

The IH40 UHF RFID Reader provides Ultra High Frequency (UHF) Radio Frequency Identification (RFID) connected to a mobile terminal. The unit can read and write to bar code, QR code and UHF RFID tags.

Note: RFID reader may differ slightly from illustrations depending on the model.

IH40 Features

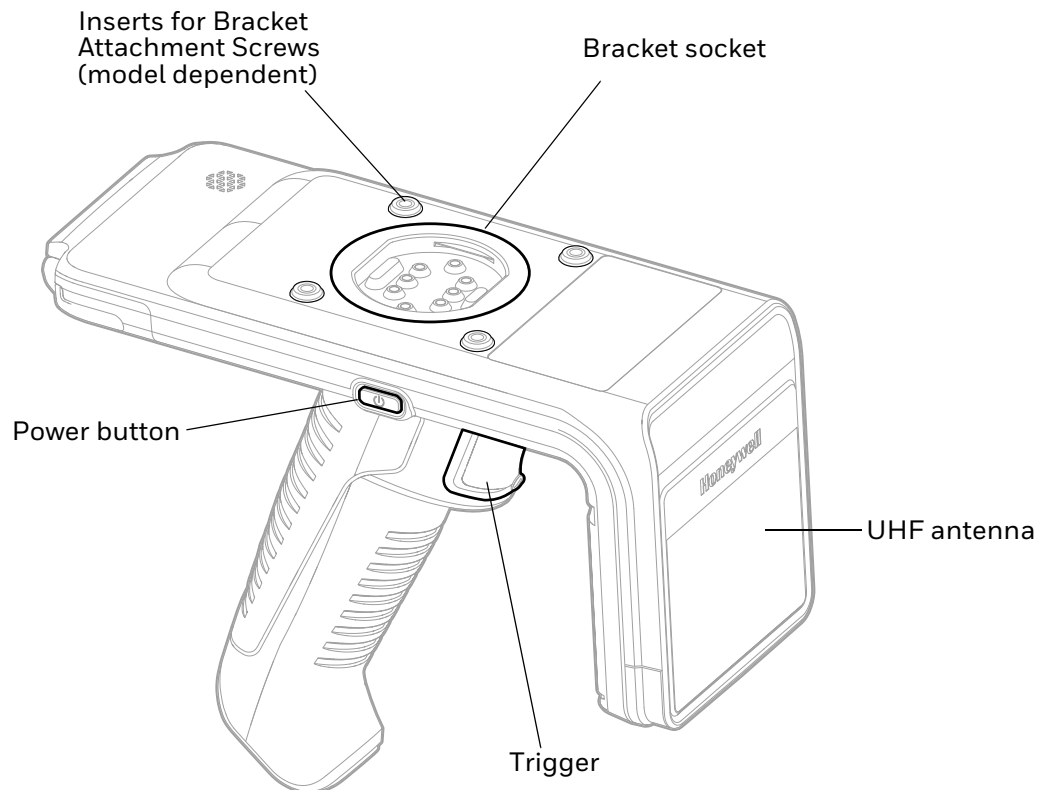

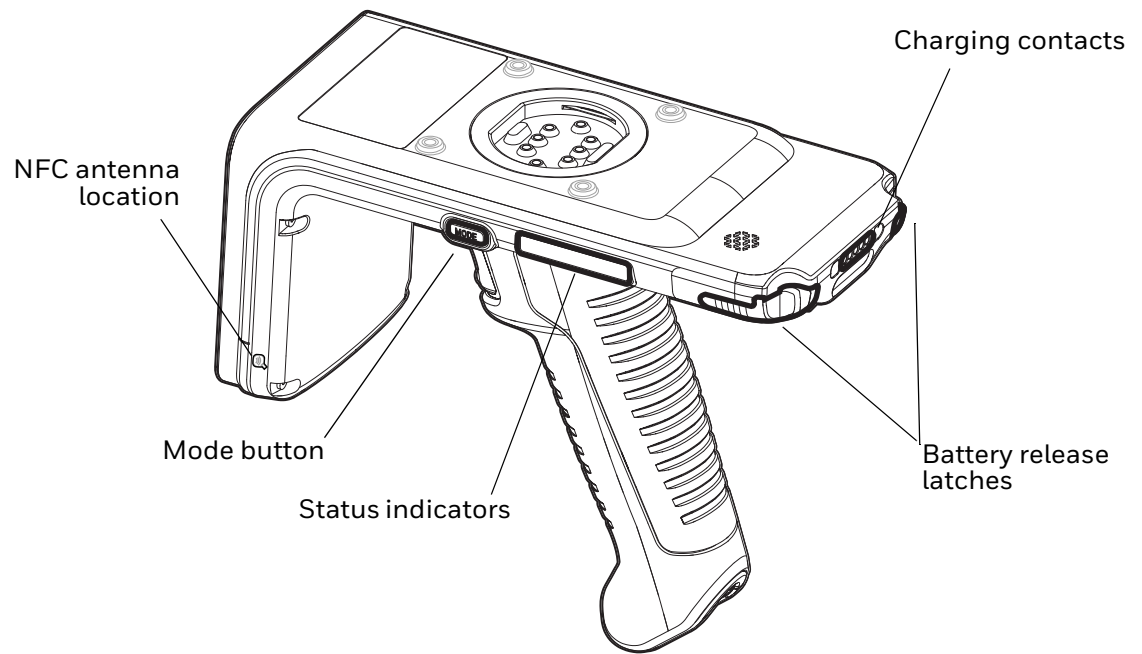

Battery Installation

Caution: Before you attempt to use, charge or replace the battery in the device, carefully read all labels, markings and product documentation provided in the box or online at sps.honeywell.com. To learn more about Battery Maintenance for Portable Devices, go to honeywell.com/PSS-BatteryMaintenance.



Avant d'essayer d'utiliser, de charger ou de remplacer la batterie de l'appareil, lisez attentivement toutes les étiquettes, marquages et documentation du produit fournis dans la boîte ou en ligne à sps.honeywell.com. Pour en savoir plus sur l'Entretien de Batteries pour Appareils Portables, consultez-le honeywell.com/PSS-BatteryMaintenance.

Install the battery before using the reader for the first time. When installing or removing the battery, hold the unit upside down in the palm of your hand.

1. To access the battery compartment, squeeze the battery cover latches and slide the door out.

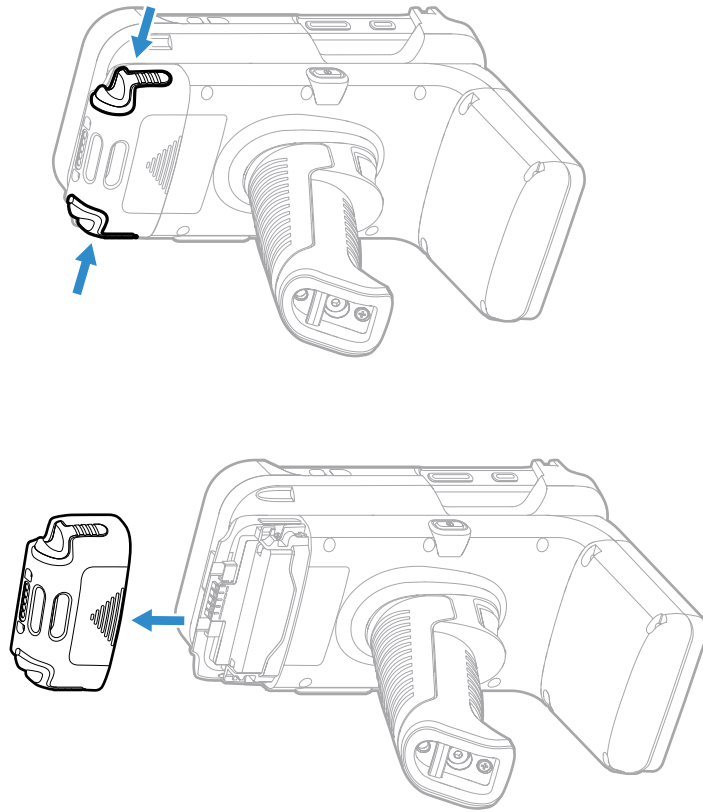

2. Insert the battery into the battery compartment.

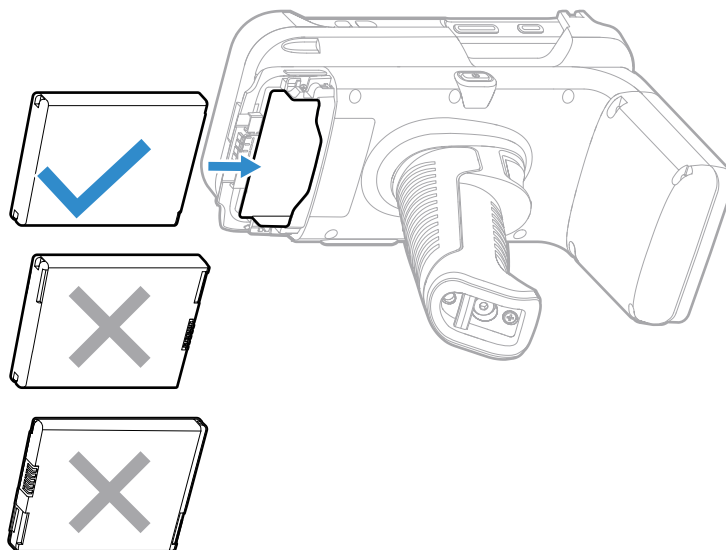

3. Slide the battery cover into the unit.

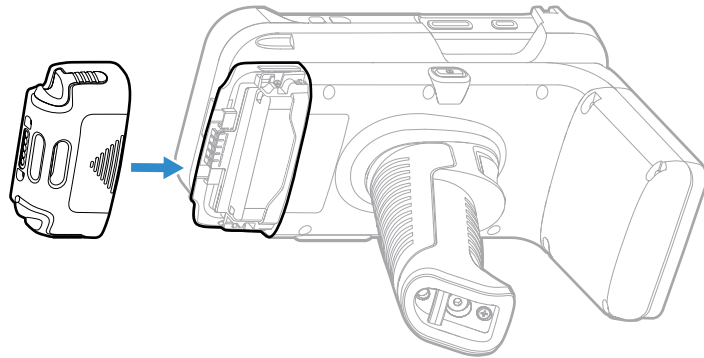

To uninstall the battery:

1. Squeeze the battery cover latches then slide the battery cover out.
2. Slide the battery out of the unit.

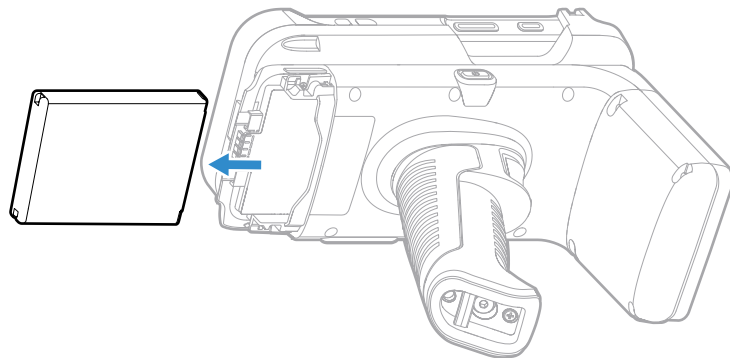

Charging

Before using the reader for the first time, ensure the battery is fully charged.

1. Attach the battery cover. Make sure that the cover clicks into place.
2. Attach the handle. Make sure that the handle clicks into place.

Docking Station Charge

The IH40 RFID Reader is compatible with all existing CT40 charge bases and universal dock chargers. To charge the IH40 RFID Reader with a booted charge base, place a non-booted device adapter sleeve into the charging cup.

The RFID Reader can be charged alone or with a mobile device attached. If a mobile computer is attached to the IH40 when it is placed in the charger, both devices will charge simultaneously.

Note: When charging, make sure the charging indicator is always on.

1. If the charge base has a booted cup, insert the device adapter sleeve into the charge dock.
2. Place the RFID Reader into the cup.

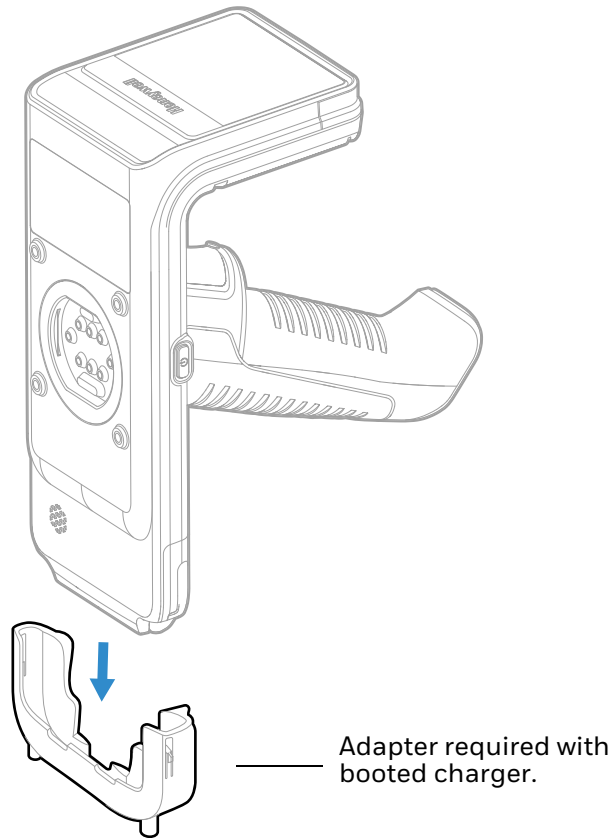

Installing/Removing Device Bracket and Attaching Device

Place the mobile computer in the bracket and attach it to the RFID reader to connect in USB mode. To connect to the RFID reader in Bluetooth mode, do not put the mobile computer in a bracket.

Note: Bracket model IH25-BR-X supports Bluetooth connection only.

Before installing the device, ensure that the charge base plug and charge base socket on the reader are clean and free from dirt or debris.

The bracket for the mobile computer is sold separately. Refer to the accessories catalog for the RFID reader or the mobile computer for information on selecting the correct bracket. Accessories catalogs are available at sps.honeywell.com.

Note: Some bracket models do not have the holes for the attachment screws. These models attach to the RFID reader socket only.

Install Device

Note: Bracket may differ slightly from illustration depending on the model.

1. Align the bracket with the socket and press the two parts together firmly until they click into place. Verify that the bracket is securely attached.

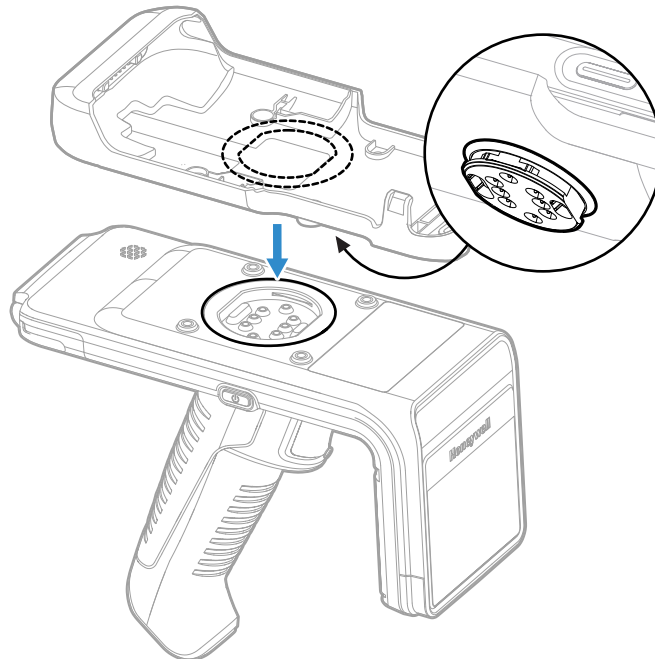

2. Insert the four screws provided with the bracket and tighten.

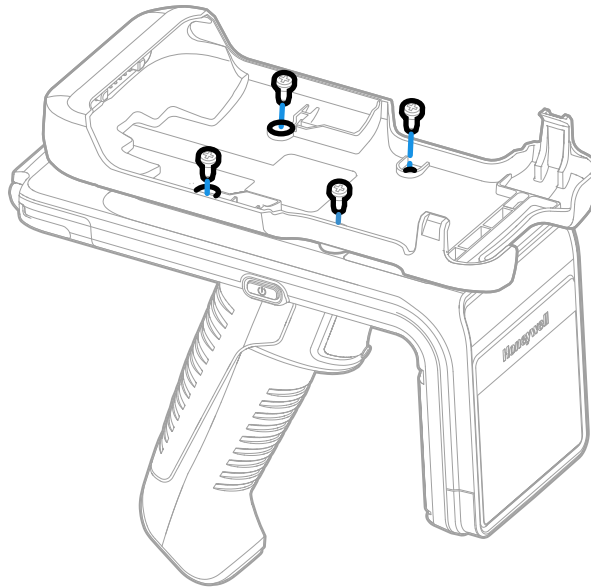

Note: The attachment screws ship with the bracket for the mobile computer. The screws are size M3x.5x6. Using a different size screw than those provided with the bracket may damage the RFID reader.

3. Insert the mobile device into the bracket and press it down.

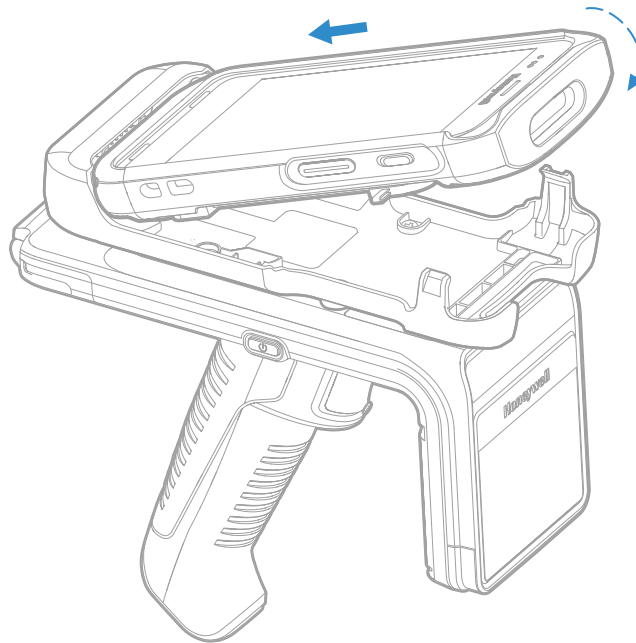

Assembled unit:

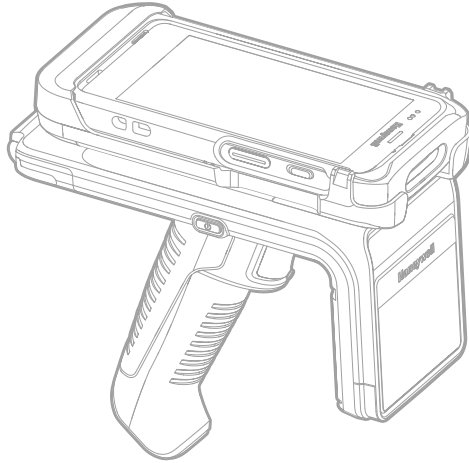

Remove the Device

1. Hold the unit by the handle.
2. Pull the mobile computer upwards out of the bracket.

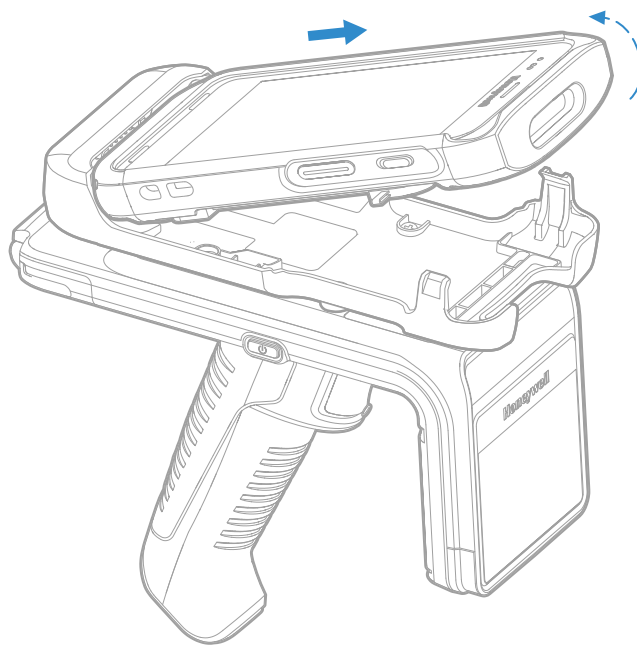

3. Remove the four attachment screws.
4. To remove the bracket, hold the handle with one hand and lift the bracket up from the RFID Reader with the other hand.

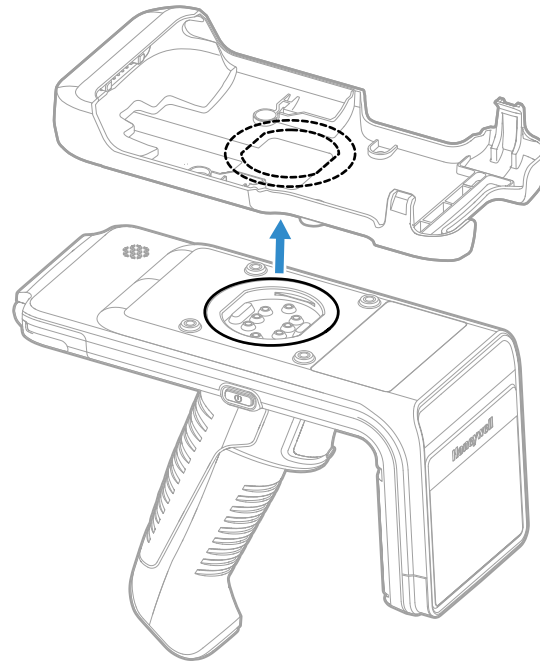

Reading RFID Tags

RFID tags can be read when they are in range. The range (typically 0.2ft-20ft) at which a tag can be read depends on the tag type and size and the number of tags in the field.



1. Turn on power to the reader. It beeps one time.
2. Power on the mobile device and launch the HONRFID app. See [Connect](#) on page 13 for instructions on connecting the mobile device to the RFID reader.
3. Press the MODE button and release within 3 seconds to check the IH40's operation mode. (Not applicable for Model IH40-O.)
 - If the RFID LED lights up, the IH40 is in RFID mode.
 - If the 1D/2D LED lights up, the IH40 is in Barcode mode.
 - Press and hold the MODE button for at least 3 seconds to switch to RFID mode.
4. Press the trigger button to read tags.

MODE Button and Status Indicators

This section describes the mode and status indicators on the IH40 RFID Reader.

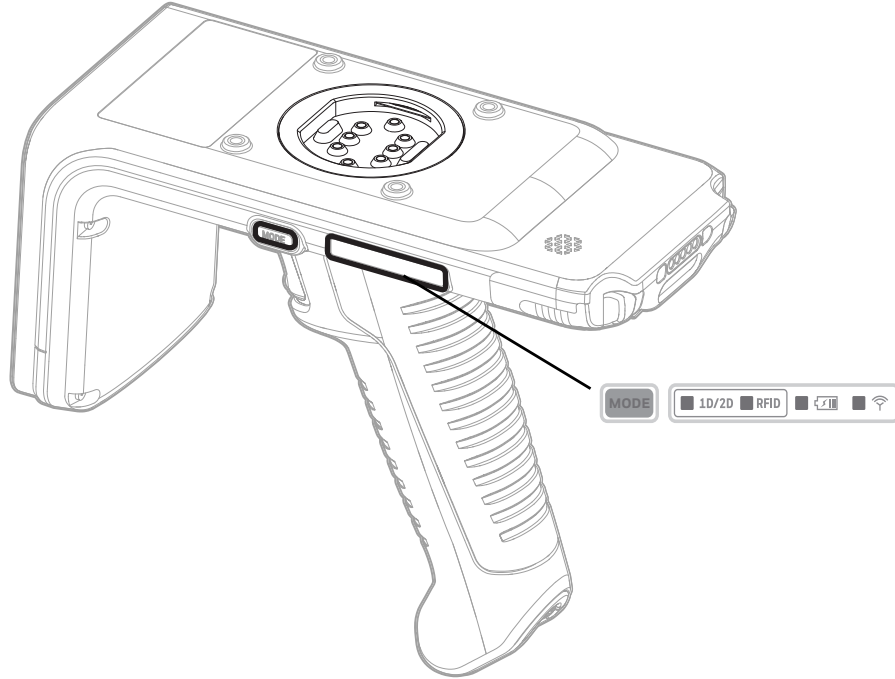
Note: *MODE button functionality does not apply to model IH40-0. Model IH40-0 uses RFID mode only.*



Indicator	Definition
	Press the MODE button to display the current mode indicator. Release the button within 3 seconds to turn the mode light off. Press and hold the MODE button for at least 3 seconds to switch between 1D/2D and RFID mode; the current mode light is on. Release the button: the current mode light is off.
	Solid amber: Charging Solid green: Fully charged Red flash/Green and amber flash alternately: Charge error Solid red: Battery low warning (<20% capacity remaining)
	Blue slow flash: Bluetooth disconnected (two beeps when disconnected from PDA) Solid blue: Bluetooth connected (one beep when connected successfully)

HONRFID MOBILE APPLICATION FOR ANDROID

Overview

This chapter describes the HonRFID Mobile Application for Android that can be used with the IH40 UHF RFID Reader.

This application runs on Android mobile devices and demonstrates IH40 functions and tag operation. It allows the user to navigate to all screens whether or not the device is connected to the IH40 reader and when the inventory/locate operation is in progress.

Note: *The content of this chapter is only based on the demo app demonstrating the basic RFID function of the IH40 RFID Reader. Customers should eventually integrate the proper SDK into the source code of their own app to fully implement the function. To get the demo app and SDK files, ask local sales staff for help. Refer to the SDK quick start guide available at sps.honeywell.com for information on integrating the SDK.*

Using the HonRFID Mobile Application for Android

To use this application for RFID operations:

1. Ensure the HonRFID Mobile Application for Android is installed on the Android mobile device.
2. Ensure the IH40 is in RFID mode.
3. Launch the HonRFID Mobile Application for Android on the mobile device.

Download the App

To download the HonRFID Mobile Application for Android:

1. Go to the *Technical Support Downloads Portal* at honeywell.com/PSSsoftware-downloads.
2. Create an account if you have not already created one. You must login to download the software.

3. Install the *Honeywell Download Manager* tool on your workstation (e.g., laptop or desktop computer) prior to trying to download any files.
4. To navigate to the HonRFID app, click on **Software > RFID > RFID Handheld Readers > IH25 > Software**.
5. To navigate to the RFID SDK, click on **Software > RFID > RFID Handheld Readers > IH40 > Software**.
To navigate to the Mobility SDK, click on **Software > Software and Tools > Developer Library > SDK for Android**.

Note: *The RFID SDK is used to enable connection by Bluetooth. The Mobility SDK is used to enable connection by USB.*

6. Select **Download** next to the software zip file.

Basic Operation

The following section explains how to use the HonRFID application.

Home Screen

To access the HonRFID Mobile Application for Android, touch the App icon  on the mobile device to display the Home screen.

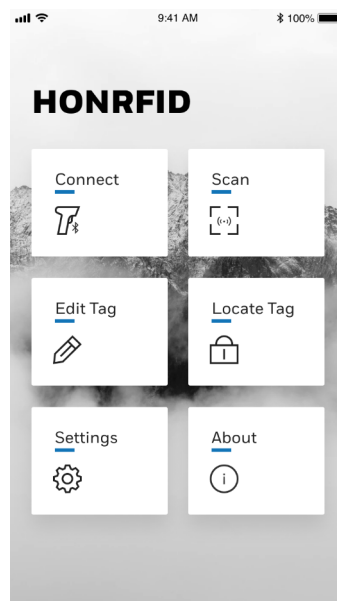

Connect

This section describes the methods available to connect a mobile device to the RFID reader. The mobile computer can be connected in either Bluetooth or USB mode. To connect in USB mode, the mobile computer must be attached to the RFID reader in a bracket.

Available connection methods depend on the bracket used to attach the mobile computer.

- Model IH25-BR-X supports Bluetooth connection only.
- Models IH40-BR, IH40-BK and CT30P-IH40 support USB connection only.

Connect by USB

Follow these steps to connect the mobile computer to the RFID Reader by USB.

1. Attach the mobile computer to the RFID Reader. (See [Installing/Removing Device Bracket and Attaching Device](#).)
2. Launch the HonRFID app on the mobile computer and tap the Connect icon on the Home Screen to go to the Connect screen.

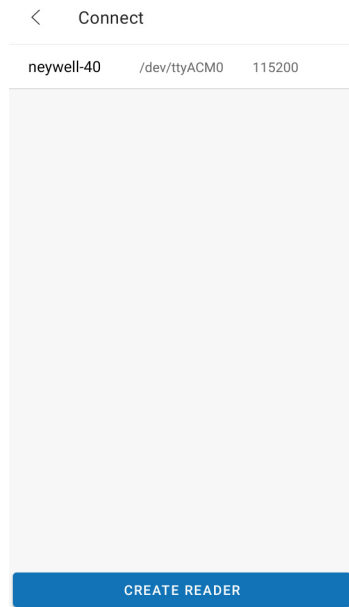

3. Tap **CREATE READER** at the bottom of the screen to pair the mobile computer with the RFID Reader and go to the Scan screen.

Note: If the name of the RFID Reader is not displayed or the Bluetooth connection screen is displayed, remove the bracket and reattach to make sure it is firmly in the socket.

Connect by Bluetooth

Follow these steps to connect the mobile computer to the RFID Reader using Bluetooth. A Bluetooth connection can be achieved manually, by using Auto Connect, by scanning the QR code on the RFID Reader, or by using NFC.

Note: Before connecting, switch on the Bluetooth function on the mobile device.

1. Tap the Connect icon on the Home Screen to go to the Connect screen.

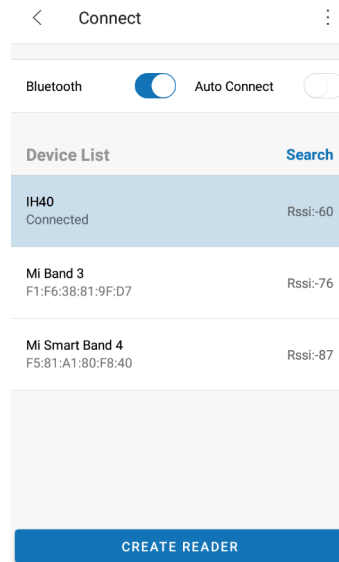

2. **Bluetooth** should be on by default. Switch Bluetooth on if necessary.
3. Tap **Search** to display a list of available Bluetooth devices.
4. Tap IH40 to connect.
5. Tap **CREATE READER** at the bottom of the screen to pair the mobile computer with the RFID Reader and go to the Scan screen.

Auto Connect by Bluetooth

1. On the Connect screen, tap **Auto Connect** to switch on this function.
2. Tap the Search button. The mobile device will search for an available Bluetooth device and connect to it automatically. It beeps one time when successfully connected.
3. Tap **CREATE READER** at the bottom of the screen to pair with the IH40 RFID Reader and go to the Scan screen.

QR Code Connect

You can scan the QR code on the RFID reader to connect by Bluetooth.

Note: The QR code reading option is only supported by Honeywell mobile devices.

1. Tap the Connect icon on the Home Screen to go to the Connect screen.
2. Tap  on the right top corner of the Connect screen and select **Barcode Way**.
3. Point the imager on the mobile computer at the QR code on the RFID Reader and press the scan button on the mobile computer. It beeps one time when successfully connected.

NFC Connect

If the mobile computer is equipped with NFC, follow these steps to connect it to the RFID Reader.

1. Tap the Connect icon on the Home Screen to go to the Connect screen.
2. Tap  on the right top corner of the Connect screen and select **NFC Way**.
3. Bring the NFC antenna on the mobile computer near the NFC antenna location on the RFID Reader. It beeps one time when successfully connected.

Scan

Note: The mobile device must be successfully connected with an IH40 RFID Reader before scanning.

1. Touch the Scan icon on the Home screen to go to the Scan screen.

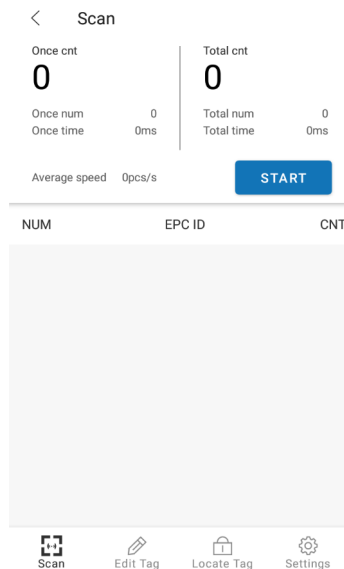

2. Tap **START** to start scanning tags that are in range.
3. Tap **STOP** to stop scanning. The scanned tags information is displayed in the list.

Note: You can also press and hold the trigger button on the IH40 to start scanning tags and release the trigger button to stop scanning in RFID mode.

Edit Tag

Touch one tag to select the tag then tap **Edit Tag** at the bottom of the screen to go to the edit screen.

WRITE TAG LOCK TAG

Selected Tag epc
E2000017890701492180360E

Memory Bank: Reserved Bank

Start Address: 2 Block Count: 2

Access Password

Data(Hex only) 0 / 8

READ WRITE

Scan Edit Tag Locate Tag Settings

Write Tag

Touch  to choose the **Memory Bank** type.

Memory Bank: Reserved Bank

Start Address: 2

Access Password: 00000000

Data(Hex only) 0 / 24

Reserved Bank
Epc Bank
Tid Bank
User Bank

Edit the **Start Address** and **Block Count** according to needs.

Lock Tag

Touch **LOCK TAG** to switch to the Lock Tag screen.

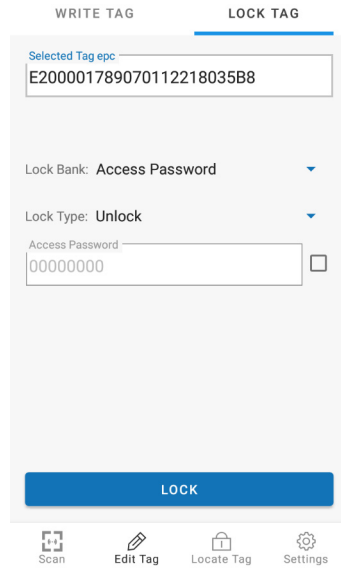

Touch  to choose the lock band and the lock type from the drop-down list. Enter the access password if necessary and touch **LOCK**.

Locate Tag

1. Touch **Locate Tag** at the bottom of the screen to go to the locate tag screen.

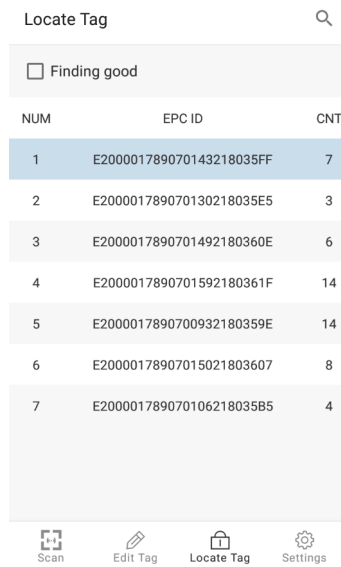

2. Touch  to type the content you want to locate in the search bar. As you type, the app automatically filters to the target tag.

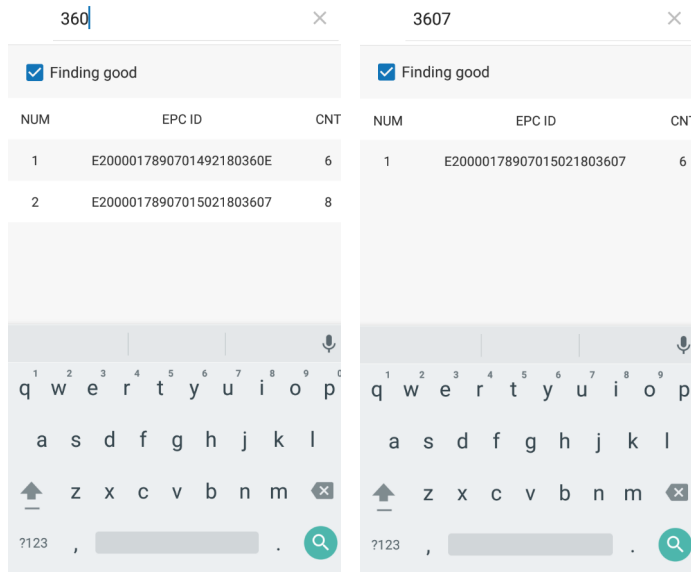

3. Select the tag you want and check "Finding good". Touch Scan to go back to the Scan screen. The located tag is highlighted in the list.

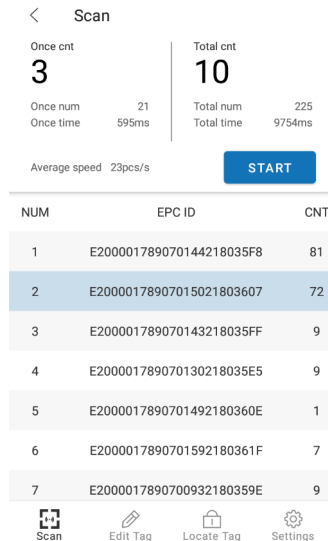

4. Touch **START** and move the mobile device to start finding the target good.

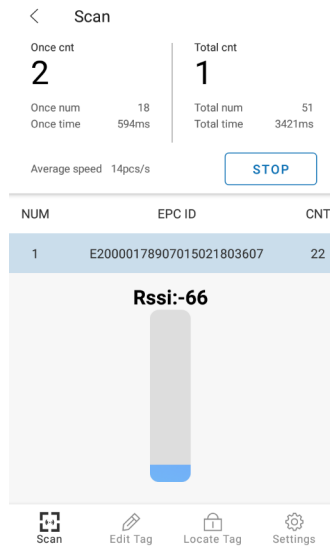

- The IH40 beeps constantly when the target good is in the available range.

Settings

Touch Settings at the bottom of the screen to go to the Common Settings screen.

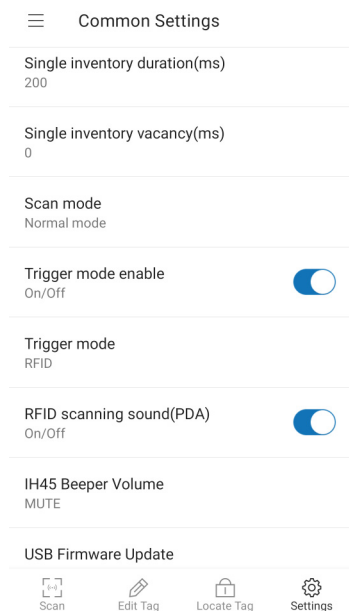

Common Settings

- Single inventory duration (Only Valid in normal mode)-Touch to set the duration.
- Single inventory vacancy (Only Valid in normal mode)-Touch to set the vacancy.
- Scan mode - Touch to set normal mode or fast mode.
- Trigger mode enable - Turn trigger mode on or off.

- Trigger mode - Select 1D/2D or RFID mode. 1D/2D uses the scan engine on the mobile computer to scan barcodes.
- RFID scanning sound(PDA) - Touch to turn on/off.
- RFID scanning sound(RFID) - Touch to turn on/off.

Touch  at the top left to go to the other settings.

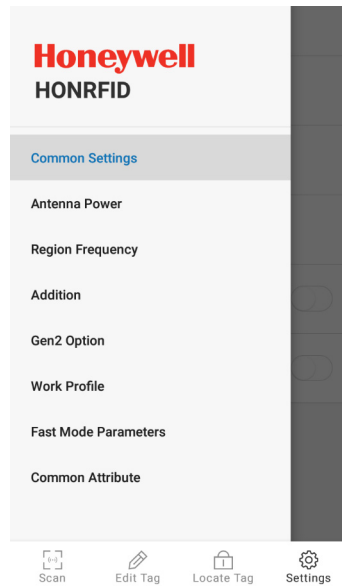

Setting	Description
Antenna Power	Ant read power Ant write power
Region Frequency	Set Region: China / Europe / N/A
Addition	Addition data type: None/Reserved Bank/Epc Bank/Tid Bank/User Bank Setting will take effect in fast mode after you check data in Return items in Fast Mode Parameters.
Gen2 Option	Session mode <ul style="list-style-type: none"> • S0: For a small number of Tags • S1: For large number of Tags • S2/S3: For special marked Tags
Fast Mode Parameters	Pause percentage: range: 0%~50% Return items: count/rssi/ant/frequency/time/pro/data
Common Attribute	<ul style="list-style-type: none"> • RFID module temperature • RFID module version • Battery level • Battery temperature • Bluetooth module version

About

Touch **About** on the Home screen to check the software version.

Update Firmware

This section provides information on how to use the HonRFID app to upgrade BLE, RFID, and USB firmware on the IH40 RFID Reader.

About Software Updates

Cyber security best practices include keeping your device apps and OS up to date. To help, Honeywell offers maintenance patches, security updates and operating system upgrades through our Honeywell Edge services.

Availability and cost depend on the following:

- Date of purchase of the device or software app.
- Warranty status.
- Service agreement status (devices) or Maintenance plan status (apps).

To learn more about Honeywell Edge Services, go to <https://sps.honeywell.com/us/en/services/productivity/support-services>.

Support for Honeywell Safety and Productivity Solutions products is available online through the [Technical Support Portal](#).

1. Go to the *Technical Support Downloads Portal* at honeywell.com/PSSsoftware-downloads.
2. Create an account if you have not already created one. You must login to download the software.
3. Install the *Honeywell Download Manager* tool on your workstation (e.g., laptop or desktop computer) prior to trying to download any files.
4. To navigate to the firmware, click on **Software > RFID > RFID Handheld Readers > IH40 > Firmware**.
5. Select **Download** next to the software zip file.

Update BLE Firmware



Follow these steps to upgrade the BLE firmware on the RFID Reader.

1. Download the Bluetooth firmware upgrade file to your computer.
2. Copy the file to the Downloads folder of the mobile computer. Refer to the user guide for the mobile computer for information on transferring files.

3. Attach the mobile computer to the RFID reader and open the HonRFID app on the mobile computer.
4. Connect the RFID Reader to the mobile device via Bluetooth.
5. Tap  on the right top corner of the screen and select **Bluetooth Fota Update**.
6. Tap the device name in the list.
7. In the Device section, tap **Connect**.
8. Tap **Select File**.
9. Tap the Bluetooth firmware upgrade file in the Downloads folder file list.
10. Tap **UPDATE**.
The app indicates that the update is finished.

Update RFID Firmware

Follow these steps to upgrade the RFID firmware on the RFID Reader.

1. Download the RFID firmware upgrade file to your computer.
2. Copy the file to the Downloads folder of the mobile computer. Refer to the user guide for the mobile computer for information on transferring files.
3. Attach the mobile computer to the RFID reader and open the HonRFID app on the mobile computer.
4. On the home screen, tap About.
5. Tap  on the right top corner of the screen then tap **Enable RFID fw update**.
6. Connect the RFID Reader to the mobile device via Bluetooth.
7. Tap **CREATE READER**.
8. Tap  on the right top corner of the screen and select **RFID firmware Update**.
9. Tap **SELECT FILE**.
10. Tap the RFID firmware upgrade file in the Downloads folder file list.
11. Tap **UPDATE**.
The app indicates that the update is finished.

Update USB Firmware

Follow these steps to upgrade the USB firmware on the RFID Reader.

Note: *The mobile computer must be connected to the IH40 RFID Reader to update the USB firmware. The “USB Firmware Update” menu option does not display when the mobile computer is not connected to an RFID Reader.*

1. Download the USB firmware upgrade file to your computer.
2. Copy the file to the Downloads folder of the mobile computer. Refer to the user guide for the mobile computer for information on transferring files.
3. Attach the mobile computer to the RFID reader and open the HonRFID app on the mobile computer.
4. On the home screen, tap **Settings**.
5. Tap **USB Firmware Update**.
6. Tap **SELECT FILE**.
7. Tap the USB firmware upgrade file in the Downloads folder file list.
8. Tap **UPDATE**.
The app indicates that the update is finished.

MAINTENANCE AND TROUBLESHOOTING

Maintenance

For trouble-free service, please observe the following tip when using the IH40 Reader:

Protect the IH40 Reader from temperature extremes. Do not leave it on the dashboard of a car on a hot day, and keep it away from heat sources.

Troubleshooting

Symptom	Possible Cause	Action
Mobile computer is attached to the RFID reader, but it cannot establish a USB connection.	The bracket is not securely engaged with the socket.	Remove the mobile computer and bracket. Reattach the bracket and ensure that it is firmly in the socket before reinstalling the screws.
Nothing happens when the button is pressed	If the LEDs are not on, then the battery may need to be charged.	Charge the reader.
	The reader may have button actions disabled.	Contact technical support.
Red flash/ Green and amber flash alternately	There is a battery fault.	Replace the battery pack.
	The battery pack temperature is outside recommended limits.	Ensure charging only occurs between 0°C - 45°C.
The host Bluetooth® discovery does not find the reader.	The reader has powered off.	Press the button and ensure the blue LED is flashing.
	The reader is out of range.	Move the reader closer to the host.
Opening the Bluetooth virtual com port does not connect to the reader.	The host has paired to a different Bluetooth device.	Pair to the required reader.
	The host Bluetooth function has an error.	Warm boot the host. If this does not help, delete the reader from the favorites list and re-pair.
Other symptoms	Other fault	Run ASCII Remote Diagnostic and contact Support.

Honeywell
855 S. Mint St.
Charlotte, NC 28202

sps.honeywell.com