

Installation Instructions for the SS490 Series Linear Hall-Effect Sensor ICs

PK 88840

Issue 7

SOLDERING INSTRUCTIONS

NOTICE

Do not wave solder surface mount sensor ICs (catalog listings with suffixes -S or -SP). Wave soldering may negatively affect sensor performance and reliability, and will void Honeywell's warranty.

Surface mount (catalog listings with suffixes -S or -SP): Use infrared reflow process with active flux, lead-free solder. Do not exceed peak temperature of 245 °C [473 °F] for a maximum of 10 seconds.

Through-hole leads: Wave solder at 250 °C to 260 °C [482 °F to 500 °F] for a maximum of three seconds. Burrs are allowed only if full length of leads will pass through 0,68 mm [0.027] dia. hole.

CLEANING INSTRUCTIONS

CAUTION

PRODUCT DAMAGE

Use agitated rinse, not pressure wash, in order to avoid forcing contaminants into the sensor package.

Failure to comply with these instructions may result in product damage.

Table 1. General Specifications for All Catalog Listings.

Characteristic	Condition	Min.	Typ.	Max.	Unit
Supply current	$T_A = 25^\circ\text{C}$ [77°F]	—	7	8.7	mA
Output current: sourcing	$V_s > 4.5$	1	1.5	—	mA
sinking	$V_s > 4.5$	0.6	1.5	—	
sinking	$V_s > 5.0$	1	1.5	—	
Response time	—	—	3	—	°s
Output voltage swing: VOM- VOM+	-B applied +B applied	0.4 $V_s - 0.4$	0.2 $V_s - 0.2$	— —	V
Supply voltage	$T_A = -40^\circ\text{C}$ to 125°C [-40°F to 257°F]	4.5	5.0	10.5	V
Operating temperature	—	-40 [40]	—	150 [302]	°C [°F]
Soldering temperature and time	wave soldering process: 250°C to 260°C [482°F to 500°F] for 3 s max. infrared reflow process: peak temperature 245°C [473°F] for 10 s max.				

Table 2. Absolute Maximum Specifications for All Catalog Listings

Characteristic	Symbol	Condition	Min.	Typ.	Max.	Unit
Supply voltage	V_s	—	-0.5	—	11	V
Output voltage	V_{out}	—	-0.5	—	11	V
Output current	I_{out}	sourcing or sinking	—	—	10	mA
Operating temperature	T_A	—	-55	—	150	°C [°F]
Storage temperature	T_S	$V_s = 0$	-55	—	165	°C [°F]

NOTICE

Absolute maximum ratings are the extreme limits the device will momentarily withstand without damage to the device. Electrical and mechanical characteristics are not guaranteed if the rated voltage and/or currents are exceeded, nor will the device necessarily operate at absolute maximum ratings.

NOTICE

The magnetic field strength (Gauss) required to cause the switch to change state (operate and release) will be as specified in the magnetic characteristics. To test the switch against the specified limits, the switch must be placed in a uniform magnetic field.



SS490 Series

Linear Hall-effect Sensor ICs

Issue 7
PK 88840

Table 3. Specifications for Catalog Listing SS494B (V_s = 5.00 V with 4.7 k output to minus, T_A = -40°C to 125°C [-40°F to 257°F])

Characteristic	Condition	Min.	Typ.	Max.	Unit
B limits for linear operation	-B max.	-375	-420	—	Gauss
	+B max.	+375	+420	—	
Linearity	B = -60 to +60	—	—	—	% of span
	B = -375 to +375	0	-1.0	-1.5	
Sensitivity	T _A = 25°C [77°F]	4.6	5.0	5.4	mV/Gauss
Null	T _A = 25°C [77°F]	2.26	2.50	2.74	V
Sensitivity drift	T _A = -40°C to 25°C [-40°F to 77°F]	0	—	+0.08	% / °C
	T _A = 25°C to 150°C [77°F to 302°F]	-0.02	—	+0.08	
Vnull drift	B = 0; T _A = -40°C to 125°C [-40°F to 257°F]	-0.064	—	+0.064	% / °C
	B = 0; T _A = 125°C to 150°C [257°F to 185°F]	-0.02	—	+0.08	

Table 4. Specifications for Catalog Listings Beginning with SS495 (V_s = 5.00 V with 4.7 k output to minus, T_A = -40°C to 125°C [-40°F to 257°F])

Characteristic	Condition	Min.	Typ.	Max.	Unit
SS495A					
B limits for linear operation	-B max.	-600	-670	—	Gauss
	+B max.	+600	+670	—	
Linearity	B = -600 to +600	0	-1.0	1.5	% of span
Sensitivity	T _A = 25°C [77°F]	3.00	3.125	3.25	mV/Gauss
Null	T _A = 25°C [77°F]	2.425	2.50	2.575	V
Sensitivity drift	T _A = -40°C to 25°C [-40°F to 77°F]	0	—	+0.06	% / °C
	T _A = 25°C to 150°C [77°F to 302°F]	-0.01	—	+0.05	
Vnull drift	B = 0; T _A = 25°C to 125°C [77°F to 257°F]	-0.06	—	+0.06	% / °C
	B = 0; T _A = 125°C to 150°C [257°F to 302°F]	-0.08	—	+0.08	
SS495A1					
B limits for linear operation	-B max.	-600	-670	—	Gauss
	+B max.	+600	+670	—	
Linearity	B = -600 to +600	0	-1.0	1.5	% of span
Sensitivity	T _A = 25°C [77°F]	3.031	3.125	3.219	mV/Gauss
Null	T _A = 25°C [77°F]	2.425	2.50	2.575	V
Sensitivity drift	T _A = -40°C to 25°C [-40°F to 77°F]	0	—	+0.06	% / °C
	T _A = 25°C to 150°C [77°F to 302°F]	-0.01	—	+0.05	
Vnull drift	B = 0; T _A = 25°C to 125°C [77°F to 257°F]	-0.04	—	+0.04	% / °C
	B = 0; T _A = 125°C to 150°C [257°F to 302°F]	-0.08	—	+0.08	
SS495A2					
B limits for linear operation	-B max.	-600	-670	—	Gauss
	+B max.	+600	+670	—	
Linearity	B = -600 to +600	0	-1.0	1.5	% of span
Sensitivity	T _A = 25°C [77°F]	2.969	3.125	3.281	mV/Gauss
Null	T _A = 25°C [77°F]	2.400	2.50	2.600	V
Sensitivity drift	T _A = -40°C to 25°C [-40°F to 77°F]	-0.01	—	+0.07	% / °C
	T _A = 25°C to 150°C [77°F to 302°F]	-0.02	—	+0.06	
Vnull drift	B = 0; T _A = 25°C to 125°C [77°F to 257°F]	-0.07	—	+0.07	% / °C
	B = 0; T _A = 125°C to 150°C [257°F to 302°F]	-0.08	—	+0.08	
SS495B					
B limits for linear operation	-B max.	-600	-670	—	Gauss
	+B max.	+600	+670	—	
Linearity	B = -600 to +600	0	-1.0	1.5	% of span
Sensitivity	T _A = 25°C [77°F]	2.875	3.125	3.375	mV/Gauss
Null	T _A = 25°C [77°F]	2.350	2.50	2.650	V
Sensitivity drift	T _A = -40°C to 25°C [-40°F to 77°F]	-0.02	—	+0.08	% / °C
	T _A = 25°C to 150°C [77°F to 302°F]	-0.02	—	+0.08	
Vnull drift	B = 0; T _A = 25°C to 125°C [77°F to 257°F]	-0.08	—	+0.08	% / °C
	B = 0; T _A = 125°C to 150°C [257°F to 302°F]	-0.08	—	+0.08	

SS490 Series

Linear Hall-effect Sensor ICs

Issue 7
PK 88840

Table 5. Specifications for Catalog Listings Beginning with SS496 ($V_s = 5.00\text{ V}$ with 4.7 k output to minus, $T_A = -40^\circ\text{C}$ to 125°C [-40°F to 257°F])

Characteristic	Condition	Min.	Typ.	Max.	Unit
SS496A					
B limits for linear operation	-B max. +B max.	-750 +750	-840 +840	— —	Gauss
Linearity	$B = -750$ to $+750$	0	-1.0	1.5	% of span
Sensitivity	$T_A = 25^\circ\text{C}$ [77°F]	2.4	2.5	2.575	mV/Gauss
Null	$T_A = 25^\circ\text{C}$ [77°F]	2.425	2.50	2.575	V
Sensitivity drift	$T_A = -40^\circ\text{C}$ to 25°C [-40°F to 77°F]	0	—	+0.06	%/ $^\circ\text{C}$
	$T_A = 25^\circ\text{C}$ to 125°C [77°F to 257°F]	-0.01	—	+0.05	
Vnull drift	$B = 0$; $T_A = 25^\circ\text{C}$ to 125°C [77°F to 257°F]	-0.048	—	+0.048	%/ $^\circ\text{C}$
	$B = 0$; $T_A = 125^\circ\text{C}$ to 150°C [257°F to 302°F]	-0.064	—	+0.064	
SS496A1					
B limits for linear operation	-B max. +B max.	-750 +750	-840 +840	— —	Gauss
Linearity	$B = -750$ to $+750$	0	-1.0	1.5	% of span
Sensitivity	$T_A = 25^\circ\text{C}$ [77°F]	2.425	2.500	2.575	mV/Gauss
Null	$T_A = 25^\circ\text{C}$ [77°F]	2.425	2.50	2.575	V
Sensitivity drift	$T_A = -40^\circ\text{C}$ to 25°C [-40°F to 77°F]	0	—	+0.06	%/ $^\circ\text{C}$
	$T_A = 25^\circ\text{C}$ to 125°C [77°F to 257°F]	-0.01	—	+0.05	
	$T_A = 125^\circ\text{C}$ to 150°C [257°F to 302°F]	-0.04	—	+0.08	
Vnull drift	$B = 0$; $T_A = 25^\circ\text{C}$ to 125°C [77°F to 257°F]	-0.032	—	+0.032	%/ $^\circ\text{C}$
	$B = 0$; $T_A = 125^\circ\text{C}$ to 150°C [257°F to 302°F]	-0.064	—	+0.064	
SS496B					
B limits for linear operation	-B max. +B max.	-750 +750	-840 +840	— —	Gauss
Linearity	$B = -750$ to $+750$	0	-1.0	1.5	% of span
Sensitivity	$T_A = 25^\circ\text{C}$ [77°F]	2.300	2.500	2.700	mV/Gauss
Null	$T_A = 25^\circ\text{C}$ [77°F]	2.350	2.50	2.650	V
Sensitivity drift	$T_A = -40^\circ\text{C}$ to 25°C [-40°F to 77°F]	-0.02	—	+0.08	%/ $^\circ\text{C}$
	$T_A = 25^\circ\text{C}$ to 150°C [77°F to 302°F]	-0.02	—	+0.08	
Vnull drift	$B = 0$; $T_A = 25^\circ\text{C}$ to 125°C [77°F to 257°F]	-0.064	—	+0.064	%/ $^\circ\text{C}$
	$B = 0$; $T_A = 125^\circ\text{C}$ to 150°C [257°F to 302°F]	-0.064	—	+0.064	

Figure 1. Block Diagram

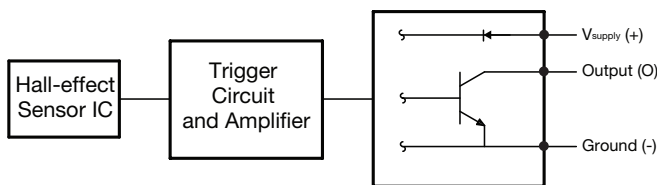

Figure 2. Maximum Supply Voltage vs Temperature

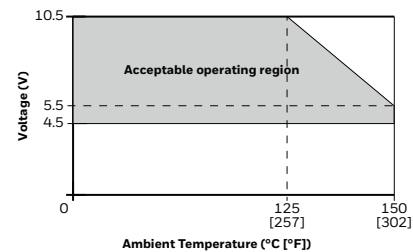
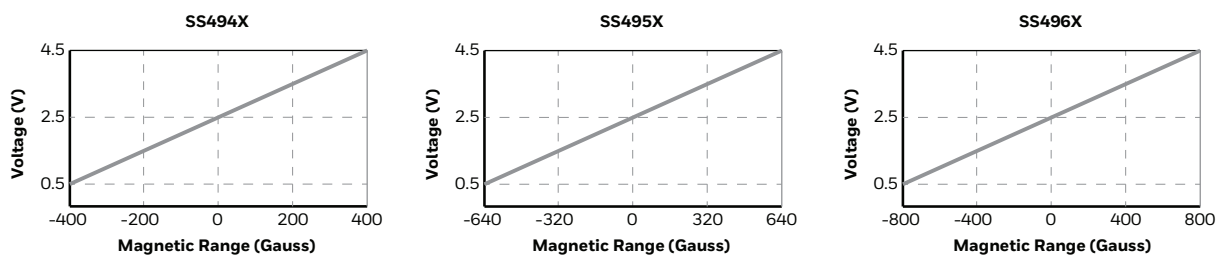

Figure 3. Transfer Characteristics: Typical Output Voltage



SS490 Series

Linear Hall-effect Sensor ICs

Issue 7
PK 88840

Figure 4. SS490 Series Flat TO-92-Style Mounting and Dimensional Drawings (For reference only: mm/[in].)

A: Straight Standard Leads Sensor IC, Bulk Pack

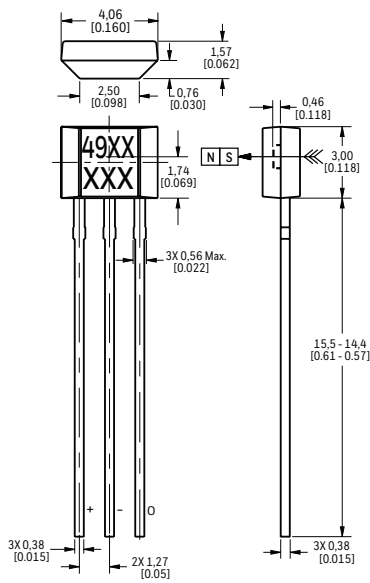

B: Straight Long Leads Sensor IC, Bulk Pack

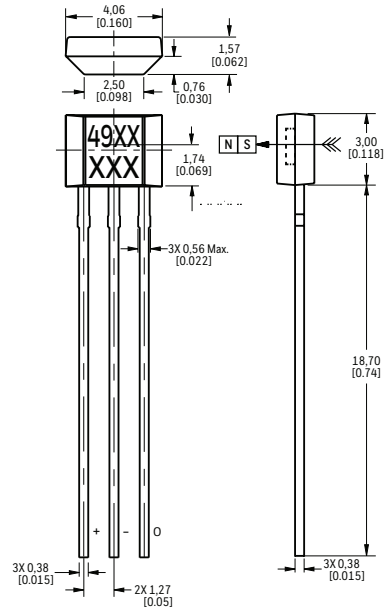

Note: Ensure the minimum hole size in the PCB is 0,68 mm [0.027] dia. based on the IPC 2222 Level B standard.

C. Formed Leads Sensor IC, Ammpack Tape-in-Box

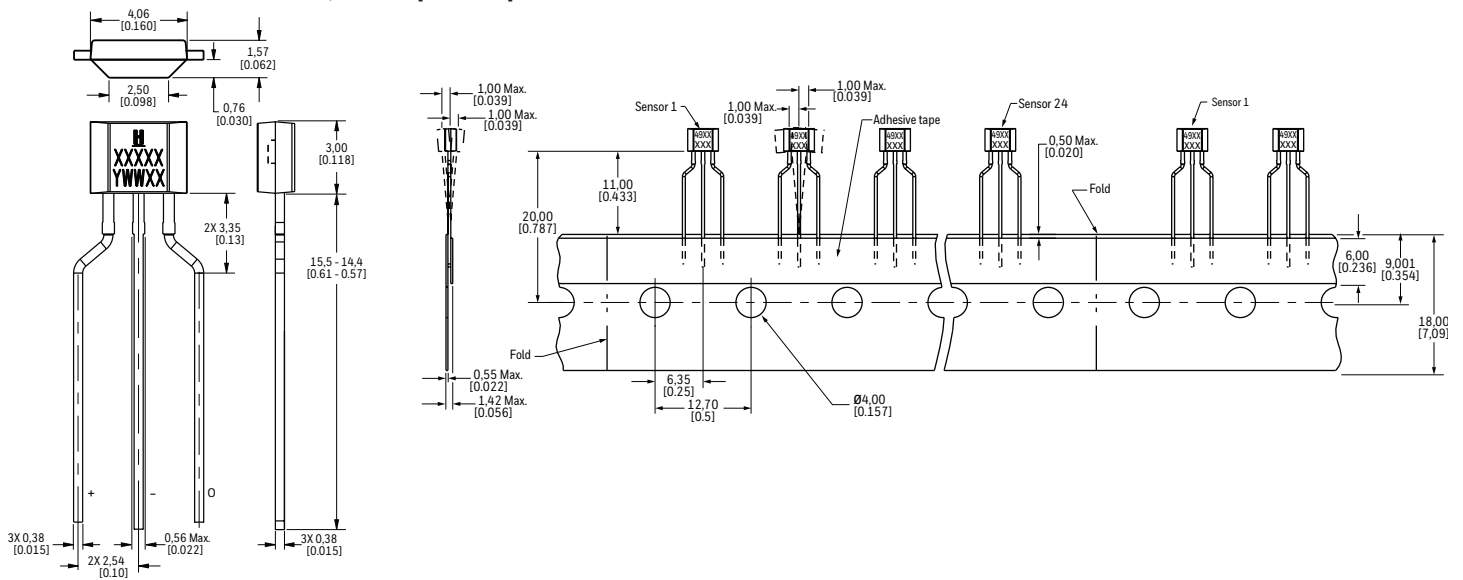

D. Straight Leads Sensor IC, Ammpack Tape-in-Box (See Figure 5.A. for individual sensor IC dimensions.)

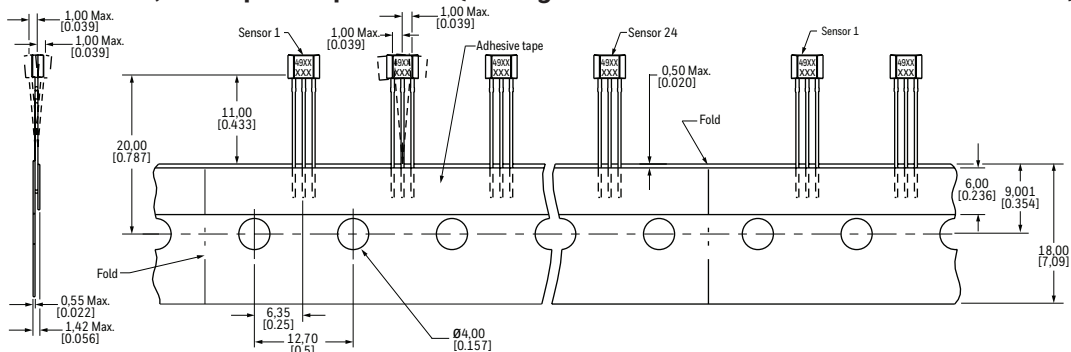

SS490 Series

Linear Hall-effect Sensor ICs

Issue 7
PK 88840

Figure 4. SS490 Series Flat TO-92-Style Mounting and Dimensional Drawings (continued)

E. Surface Mount Sensor IC, Bulk Pack

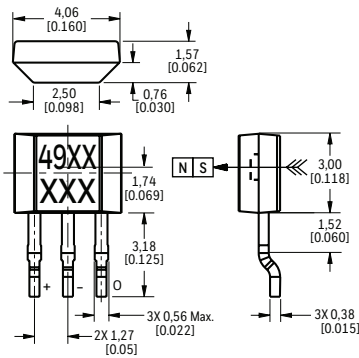

F. Surface Mount Sensor IC, Pocket Tape and Reel (See Figure 5.E. for individual sensor IC dimensions.)

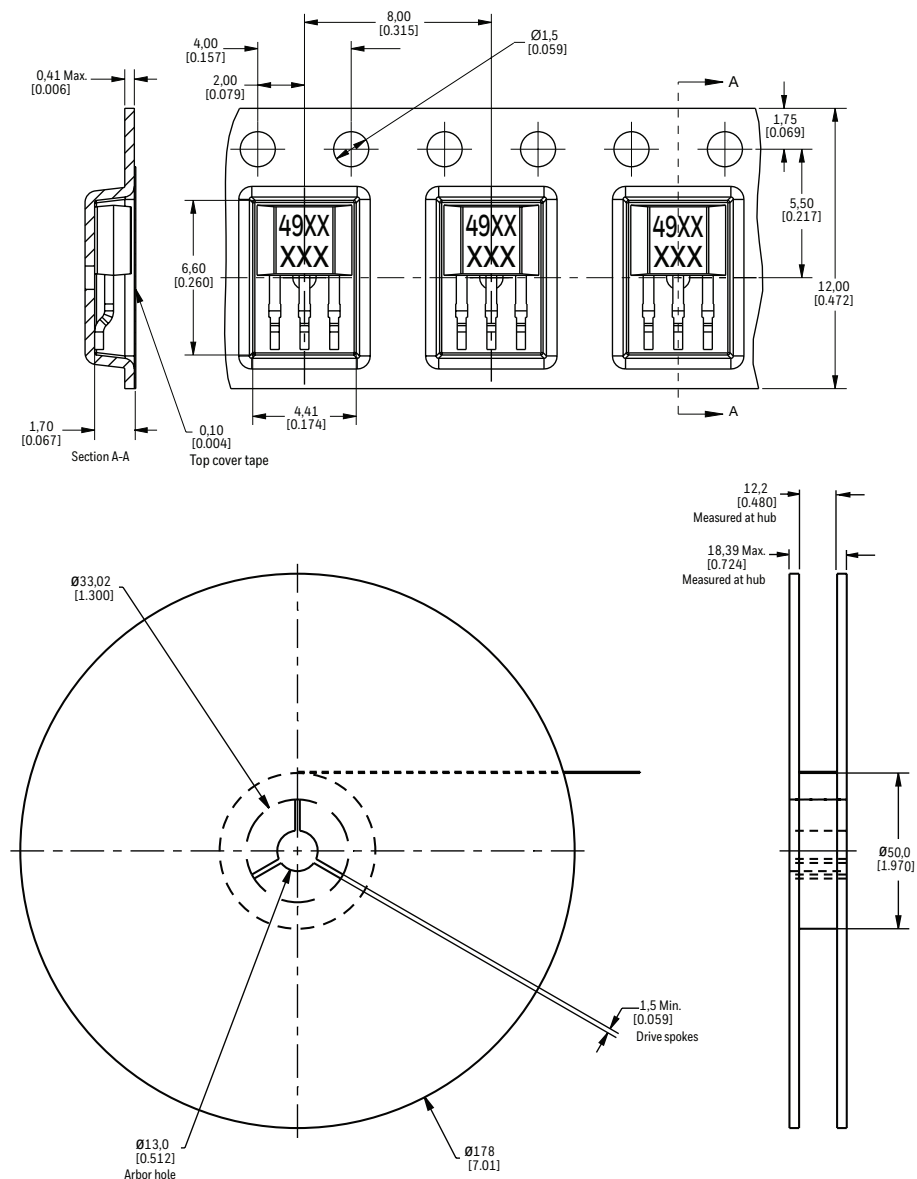

⚠️ WARNING

PERSONAL INJURY

DO NOT USE these products as safety or emergency stop devices or in any other application where failure of the product could result in personal injury.

Failure to comply with these instructions could result in death or serious injury.

Warranty/Remedy

Honeywell warrants goods of its manufacture as being free of defective materials and faulty workmanship during the applicable warranty period. Honeywell's standard product warranty applies unless agreed to otherwise by Honeywell in writing; please refer to your order acknowledgement or consult your local sales office for specific warranty details. If warranted goods are returned to Honeywell during the period of coverage, Honeywell will repair or replace, at its option, without charge those items that Honeywell, in its sole discretion, finds defective.

The foregoing is buyer's sole remedy and is in lieu of all other warranties, expressed or implied, including those of merchantability and fitness for a particular purpose. In no event shall Honeywell be liable for consequential, special, or indirect damages.

While Honeywell may provide application assistance personally, through our literature and the Honeywell web site, it is buyer's sole responsibility to determine the suitability of the product in the application.

Specifications may change without notice. The information we supply is believed to be accurate and reliable as of this writing. However, Honeywell assumes no responsibility for its use.

For more information

Honeywell Sensing and Internet of Things services its customers through a worldwide network of sales offices and distributors. For application assistance, current specifications, pricing or the nearest Authorized Distributor, visit sensing.honeywell.com or call:

Asia Pacific	+65 6355-2828
Europe	+44 (0) 1698 481481
USA/Canada	+1-800-537-6945

Honeywell Sensing and Internet of Things

9680 Old Bailes Road
Fort Mill, SC 29707
www.honeywell.com

PK 88840-7-EN | 7 | 06/18
© 2018 Honeywell International Inc.

Honeywell