

Installation Instructions for the Honeywell HumidCon™ Digital Humidity/Temperature Sensors: HIH6130/6131 Series with SPI Communication

GENERAL INFORMATION

The following associated literature is available on the [Web](#):

- Product data sheet
- Product application note
- Application sheets:
 - Humidity Sensor Performance Characteristics
 - Humidity Sensor Theory and Behavior
 - Humidity Sensor Moisture and Psychrometrics
 - Humidity Sensor Chemical Resistivity
 - Thermoset Polymer-based Capacitive Sensors
- Technical Notes:
 - SPI Communication with the Honeywell HumidCon™ Digital Humidity/Temperature Sensors
 - Using Alarms on the Honeywell HumidCon™ Digital Humidity/Temperature Sensors
 - Entering and Using Command Mode on the Honeywell HumidCon™ Digital Humidity/Temperature Sensors
 - Total Error Band Specification for Honeywell Digital Humidity/Temperature Sensors

CAUTION

IMPROPER HANDLING

- Do not remove the sensor from its original protective packaging until it is ready to be installed.
- Do not touch the sensor surface. Use latex finger cots. Handle the sensor by its package edges or leads.
- Do not allow objects to enter the cavity of the sensor element.
- Do not allow debris or contaminants to accumulate on the filter.

Failure to comply with these instructions may result in product damage.

SOLDERING AND ASSEMBLY

CAUTION

IMPROPER CLEANING

- Insert and solder the sensor after the PCB cleaning process.

Failure to comply with these instructions may result in product damage.

CAUTION

IMPROPER SENSOR POSITIONING

- Position the sensor so that its face is exposed to the atmosphere being monitored.

Failure to comply with these instructions may result in product damage.

CAUTION

IMPROPER SOLDERING

- For better product reliability, the HIH6130/6131 Series is factory-shipped with a protective tape on the cover (sensing face). This tape must remain in place during soldering.
- After soldering, remove the protective tape as described below to activate the sensor.

Failure to comply with these instructions may result in product damage.

PROTECTIVE TAPE REMOVAL

1. Use proper ESD protection.
2. Using covered fingers or tweezers to ensure that no debris falls into the filter, sensor cover or die, grip the overhanging front edge of the protective tape and peel it back from the top surface of the sensor.
3. Ensure the complete rectangle of protective tape is removed.

Figure 1. Protective Tape Removal

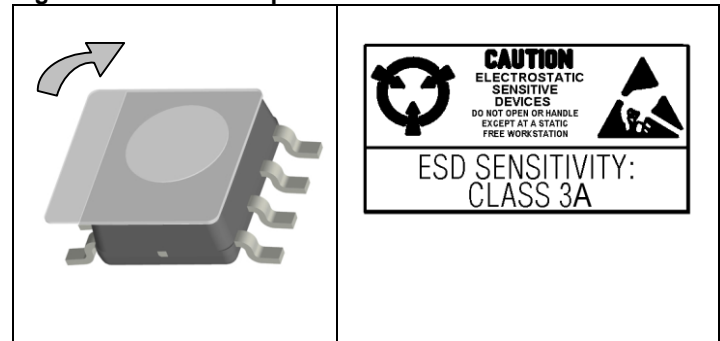

SOLDERING

Process

- Automated: Use a no-clean flux. Limit the contact of the flux to the leads only. Reflow soldering profile is specified by J-STD-020D for a small package with a peak temperature of 260 °C [500 °F].
- Manual: Do not exceed 350 °C [662 °F] for 4 s max.

SENSOR REHYDRATION

NOTICE

SENSOR REHYDRATION

- Exposure to elevated temperatures, such as those experienced during solder reflow, may dry out the sensing element. It is recommended that the sensor be allowed time to rehydrate after soldering or other high temperature/dry exposures.
- Exposure to these conditions will not permanently damage the sensor. It will generally return to its factory-calibrated value after rehydration.
- If rehydration is not performed, the sensor may read a slight offset that slowly disappears over time as the sensor becomes exposed to ambient conditions. Conversely, extended exposure to condensing and high humidity environments (>90 %RH) may cause a revisable shift in readings which will generally return to normal after the sensor has been allowed to dry off.

To rehydrate the sensor, expose it to room temperature under ambient conditions (>50 %RH) for a minimum of five hours.

MOISTURE SEALING THE LEADS

If, in the presence of intermittent moisture or other contaminants, there is the possibility of galvanic paths between the leads, moisture seal the leads and exposed pads.

Table 1. Environmental Specifications

Characteristic	Condition	Min.	Typ.	Max.	Unit
Operating temperature range	–	-25 [-13]	–	85 [185]	°C [°F]
Storage temperature range	–	-40 [-40]	–	85 [185]	°C [°F]
Storage humidity	–	30	–	50	%RH
Soldering:					
automated	IPC/EIA/JEDEC J-STD-020D	–	–	260 [500]	°C [°F]
manual	apply heat for 4 s max. for manual soldering	–	–	350 [662]	
ESD	MIL-STD 883H, Method 3015.7	–	–	±4	kV
Latch-up immunity	–	–	–	±100	mA
Shock	MIL-STD 202G, Method 213D, Test Condition C, half-sine, 6 ms ±3 perpendicular axis, 3 shock pulses per axis	–	–	100	g
Vibration	MIL-STD 202G, Method 204D, Test Condition D, 10 Hz to 2000 Hz	–	–	20	g
Light sensitivity	exposed to 50 lumens yellow light; exhibited no change in output				

Table 2. Humidity Performance Specifications

Characteristic	Condition	Min.	Typ.	Max.	Unit
Supply voltage variation	2.3 Vdc to 5.5 Vdc	–	0.1	0.5	%RH
Compensated humidity range ¹	–	10	–	90	%RH
Compensated temp. range ¹	–	5 [41]	–	50 [122]	°C [°F]
Resolution	14 bit ADC resolution	–	–	0.04	%RH
Accuracy ²	–	–	–	±4	%RH
Total error band ³	–	–	–	±5	%RH
Response time	airflow minimum 20 l/min	–	6	8	s
Operating range	non-condensing	0	–	100	%RH
Long term stability	50 %RH for 5 years	–	±0.05	±1.2	%RH
Impact of soldering	IPC/EIA/JEDEC J-STD-020D, peak temp. of 260 °C [500 °F]	–	–	±2.5	%RH

Notes:

1. Conversion formulas:

<p>14 bit ADC output for humidity to %RH:</p> $\text{Humidity}(\%RH) = \frac{\text{Humidity_14_bit_ADC_output}}{2^{14} - 2} \times 100$	<p>14 bit ADC output for temperature to %RH:</p> $\text{Temperature}(\text{°C}) = \frac{\text{Temperature_14_bit_ADC_output}}{2^{14} - 2} \times 165 - 40$
---	--

2. Accuracy is specified at the typical supply voltage of 3.3 Vdc and at 25 °C [77 °F]. It is the maximum deviation from the ideal transfer function of relative humidity measured over the humidity range of 10 %RH to 90 %RH and includes all errors due to humidity non-linearity, humidity hysteresis and humidity non-repeatability.
3. Total error band is the maximum deviation from the ideal transfer function of relative humidity over the compensated range of 5 °C [41 °F] to 50 °C [122 °F]. It includes all errors due to humidity non-linearity, humidity hysteresis, humidity non-repeatability, thermal effect on zero, thermal effect on span and thermal hysteresis.

Table 3. Temperature Performance Specifications

Characteristic	Condition	Min.	Typ.	Max.	Unit
Supply voltage variation	2.3 Vdc to 5.5 Vdc	–	0.5	1.0	°C
Compensated temp. range	–	5 [41]	–	50 [122]	°C [°F]
Resolution	14 bit ADC resolution	–	–	0.025	°C
Accuracy (BFSL) ¹	–	–	–	±1.0	°C
Response time	1/e slow moving air	5	–	30	s
Long term stability	25 °C for 5 years	–	–	±0.05	°C/yr
Impact of soldering	IPC/EIA/JEDEC J-STD-020D, peak temp. of 260 °C [500 °F]	–	–	±0.1	°C

Note:

1. Accuracy is specified over the compensated temperature range.

Table 4. Current Consumption

Characteristic	V _{DD}	Abbr.	Condition	Typ.	Max.	Unit
Sleep current	3.3	I _{SLEEP}	–	0.6	1	µA
Supply current	3.3	I _{DD}	14 bit fastest update, no sleep	0.75	1	mA

Table 5. Input and Output Characteristics

Characteristic	Abbr.	Condition	Min.	Typ.	Max.	Unit
Supply voltage	V _{DD}	–	2.3	3.3	5.5	Vdc
Low level output voltage	V _{OL}	I _{OL} = 2.8 mA min.	–	–	20%	V _{DD}
High level output voltage	V _{OH}	I _{OH} = -2.8 mA min.	80%	–	–	V _{DD}
Low level input voltage	V _{IL}	–	–	–	20%	V _{DD}
High level input voltage	V _{IH}	–	80%	–	–	V _{DD}
SPI pull-up resistor (for SS only)	R _{SS}	–	–	10	–	kOhm

Table 6. Measurement Timing

Characteristic	Abbr.	Condition	Min.	Typ.	Max.	Unit
Start-up time (Power-On to data ready)	T _{STA}	14 bit temperature and 14 bit humidity resolution	–	50	60	ms
Update rate	application dependent: measurements are taken only when the application requests them					

Figure 2. SPI Timing Diagram

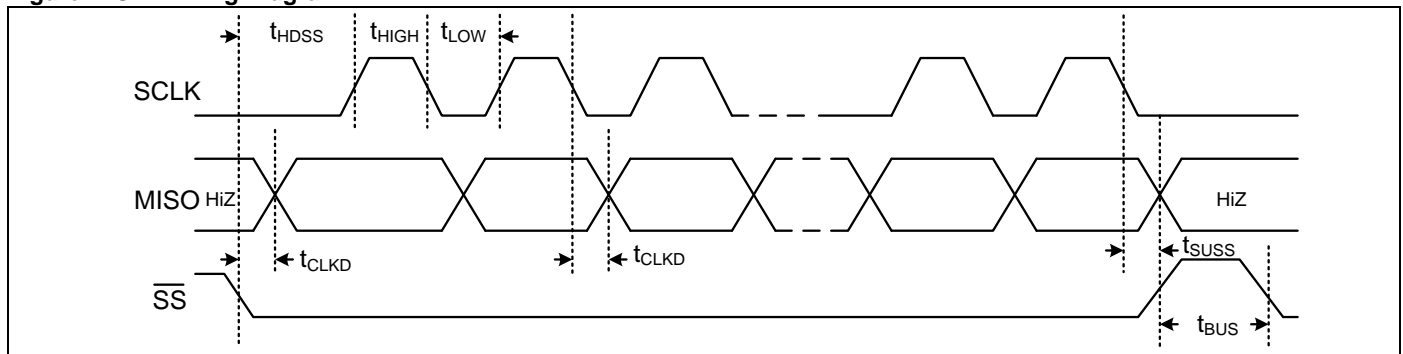

Characteristic	Abbr.	Min.	Typ.	Max.	Unit
SCLK clock frequency	f _{SCL}	50	–	800	kHz
SS drop to first clock edge	t _{HDSS}	2.5	–	–	µs
Minimum SCLK clock low width ¹	t _{LOW}	0.6	–	–	µs
Minimum SCLK clock high width ¹	t _{HIGH}	0.6	–	–	µs
Clock edge to data transition	t _{CLKD}	0	–	0.5	µs
Rise of SS relative to last clock edge	t _{SUSS}	0.1	–	–	µs
Bus free time between rise and fall of SS	t _{BUS}	2	–	–	µs

Note 1: Combined low and high widths must equal or exceed minimum SCLK period.

Figure 3. Mounting Dimensions, PCB Landing Pattern and Pinout (For reference only. mm/[in])

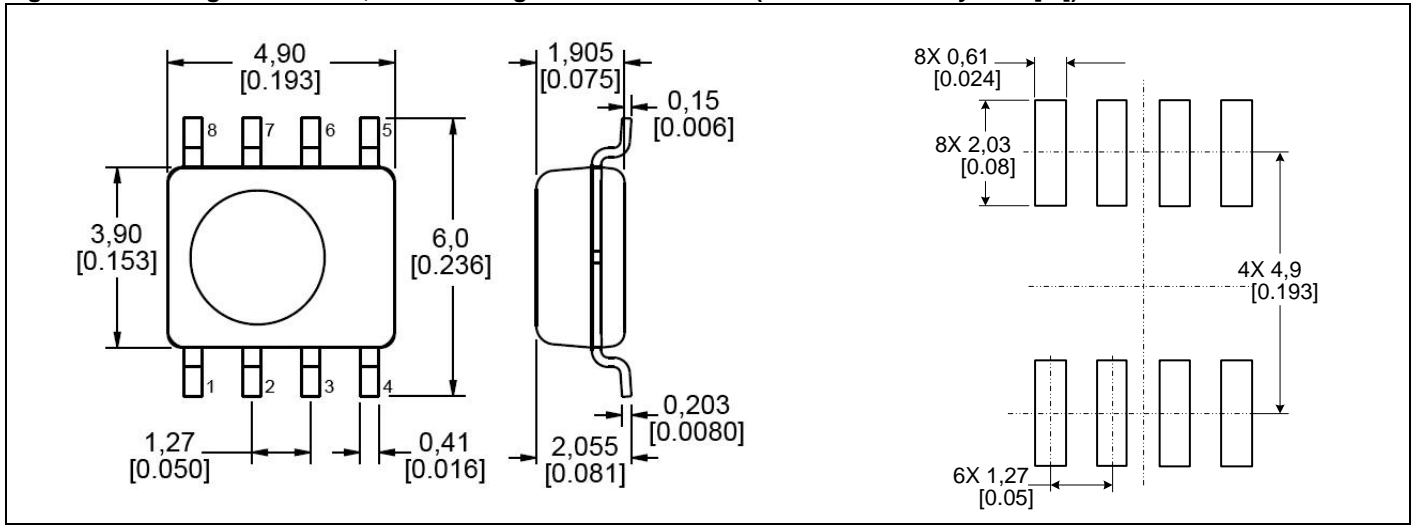

Pin	ASIC Pad	Description
1	V _{CORE}	connect via 0.1 μF to ground
2	V _{SS}	supply ground
3	SS	slave select (input)
4	SCLK	serial clock
5	MISO	master-in-slave-out
6 ¹	AL_L	alarm output low
7	NC	not connected externally
8	V _{DD}	supply voltage, connect via 0.22 μF to ground

Note:

1. Do not connect Pin 6 if the built-in alarm feature is not desired.

Figure 4. Tape and Reel Dimensions (For reference only. mm/[in])

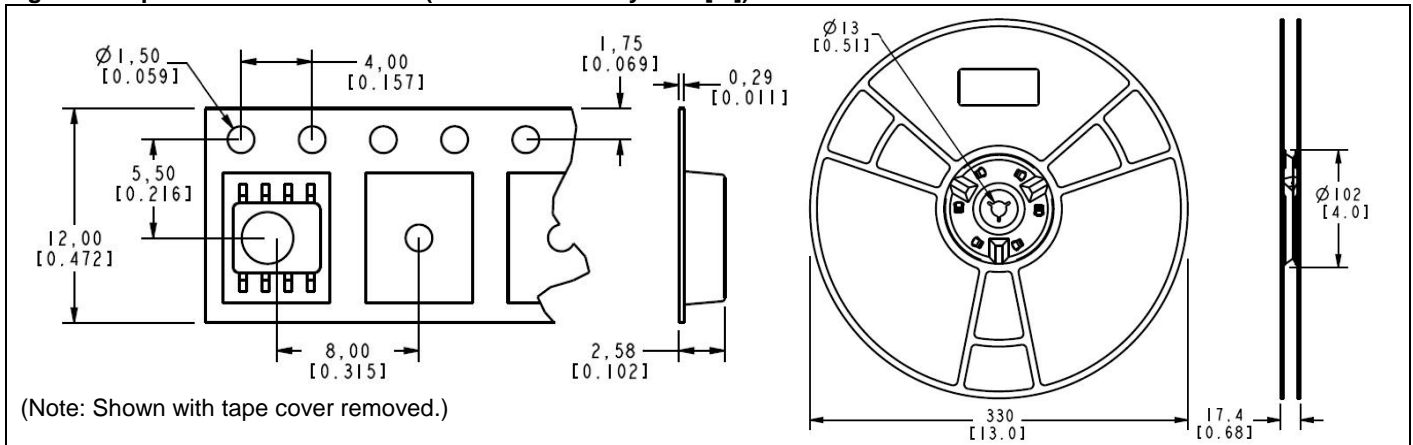

Figure 5. Typical Application Circuit

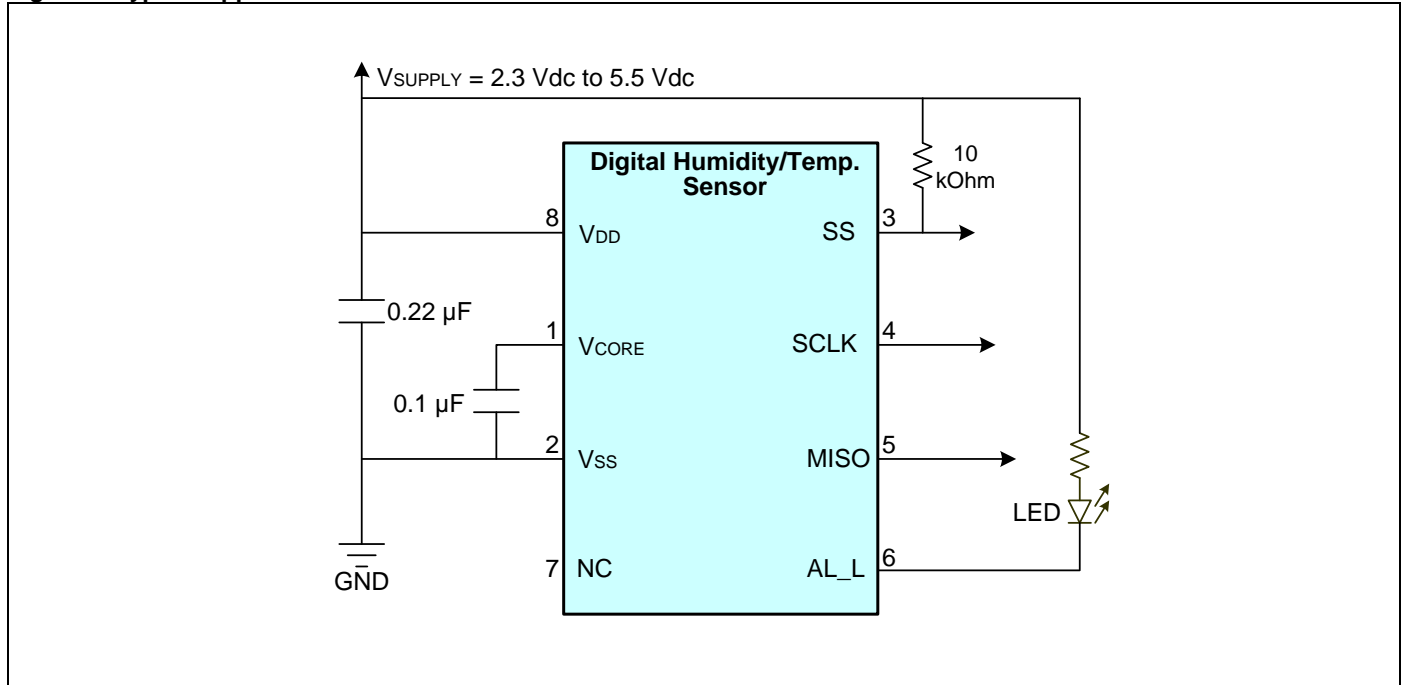

Figure 6. HIH6130/6131 Series Maximal Accuracy¹ (Performance is specified between 10 %RH and 90 %RH.)

Relative Humidity (%RH)	90	±1	±2	±2	±2	±3	±3	±3	±3	±3	±2
	80	±1	±2	±2	±2	±2	±2	±2	±2	±2	±1
	70	±2	±2	±2	±2	±2	±2	±2	±2	±2	±2
	60	±2	±3	±3	±3	±3	±3	±3	±3	±3	±2
	50	±2	±3	±3	±3	±3	±3	±3	±3	±3	±2
	40	±2	±3	±3	±3	±3	±3	±3	±3	±3	±2
	30	±2	±3	±3	±3	±3	±3	±3	±3	±3	±2
	20	±1	±3	±3	±3	±3	±3	±3	±3	±3	±1
	10	±1	±3	±3	±3	±3	±3	±3	±3	±3	±1
	0	±1	±3	±3	±3	±3	±3	±3	±3	±3	±1
		10	20	30	40	50					
		Temperature (°C)									

Note:

1. Maximal accuracy is the mean value between rising and falling RH points.

WARNING

PERSONAL INJURY

- DO NOT USE these products as safety or emergency stop devices or in any other application where failure of the product could result in personal injury.
- The sensor's housing does not provide electrical safety isolation. Mount the sensor in a location where it cannot be touched, or where a surrounding barrier prevents human contact.

Failure to comply with these instructions could result in death or serious injury.

WARRANTY/REMEDY

Honeywell warrants goods of its manufacture as being free of defective materials and faulty workmanship. Honeywell's standard product warranty applies unless agreed to otherwise by Honeywell in writing; please refer to your order acknowledgement or consult your local sales office for specific warranty details. If warranted goods are returned to Honeywell during the period of coverage, Honeywell will repair or replace, at its option, without charge those items it finds defective. **The foregoing is buyer's sole remedy and is in lieu of all other warranties, expressed or implied, including those of merchantability and fitness for a particular purpose. In no event shall Honeywell be liable for consequential, special, or indirect damages.**

While we provide application assistance personally, through our literature and the Honeywell web site, it is up to the customer to determine the suitability of the product in the application.

Specifications may change without notice. The information we supply is believed to be accurate and reliable as of this printing. However, we assume no responsibility for its use.

SALES AND SERVICE

Honeywell serves its customers through a worldwide network of sales offices, representatives and distributors. For application assistance, current specifications, pricing or name of the nearest Authorized Distributor, contact your local sales office or:

E-mail: info.sc@honeywell.com

Internet: www.honeywell.com/sensing

Phone and Fax:

Asia Pacific	+65 6355-2828
	+65 6445-3033 Fax
Europe	+44 (0) 1698 481481
	+44 (0) 1698 481676 Fax
Latin America	+1-305-805-8188
	+1-305-883-8257 Fax
USA/Canada	+1-800-537-6945
	+1-815-235-6847
	+1-815-235-6545 Fax