

AWM700 Series 200 LPM Mass Airflow Sensor

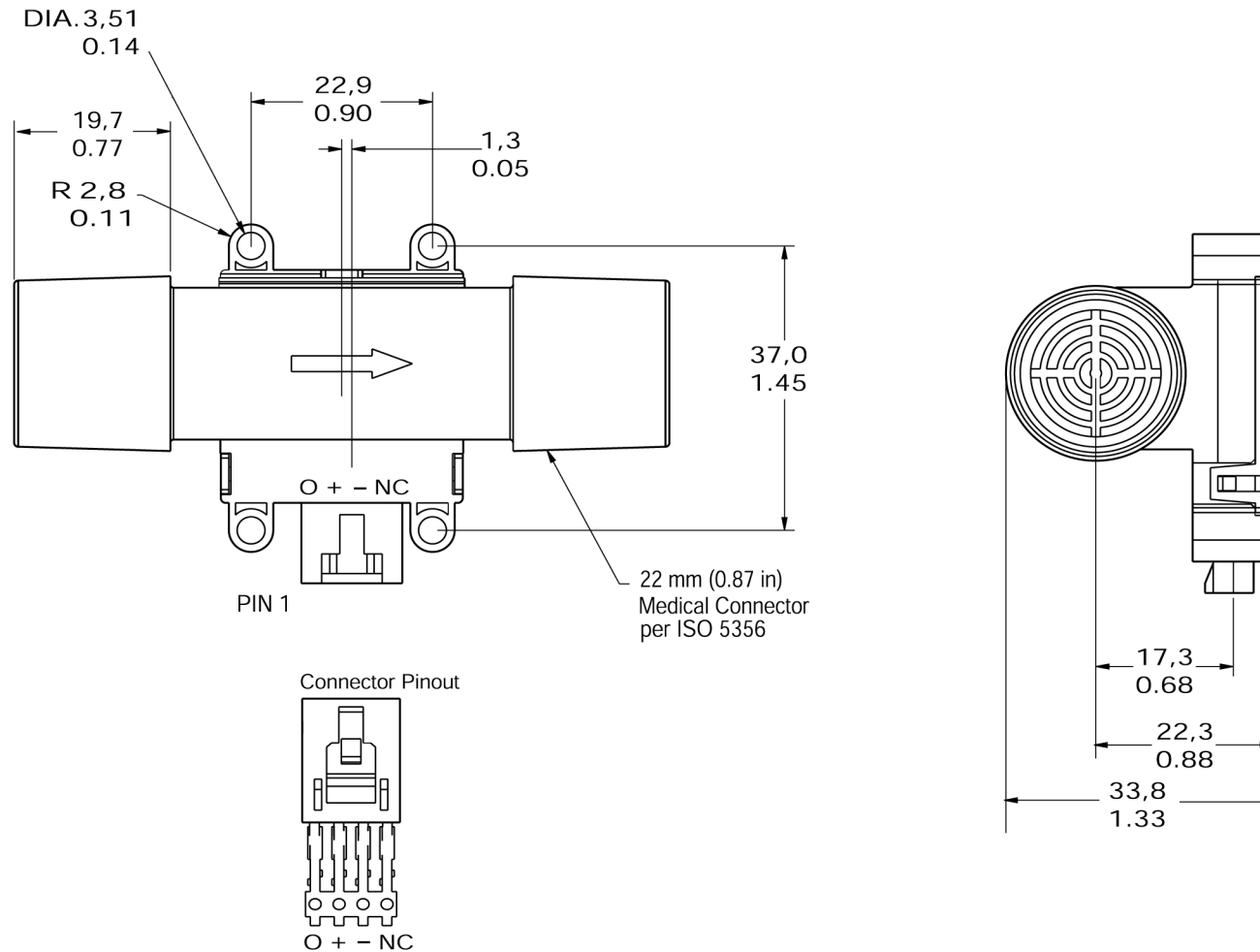

AWM700 Series 200 LPM Airflow Sensor

Mounting Dimensions (for reference only) mm/in



Honeywell

AWM700 Series 200 LPM Airflow Sensor

Features and Benefits

Feature	Benefit
Package designed for ranges up to 200 SLPM	Small package size with flow ranges up to 200 SLPM
Latching connector design	Ensures reliable electrical connection
Highly stable null and full-scale	Accurate over life, reduces need for recalibration
Compact package design	Well suited for use in portable devices
Autoclave applications	Offers a wide range of cleaning/disinfecting options
Extremely low pressure drop, 1 inch H ₂ O; 2,5 mBar typ.	Increases customer system efficiency
Chemical resistance	Compatible with a wide range of anesthesia gases
Extremely low hysteresis and repeatability errors (less than 0.35% of reading)	High sensor accuracy
Fast response time (6 ms, typ.)	Fast system response
Wide operating temperature range (-25° C to +85° C)	Allows sensor to be designed into many different types of equipment
Low power consumption (< 65 mW)	Ideal for battery powered applications
Excitation voltage - wide input voltage (8 to 15 Vdc)	Provides flexibility in power supply selection

Honeywell

AWM700 Series 200 LPM Airflow Sensor

Typical Applications

- **Medical equipment**
 - Oxygen concentrators
 - Oxygen conservers
 - Respirators and ventilators
 - Sleep apnea monitors
 - Nebulizers
 - Continuous positive airway pressure (CPAP) equipment
- **Analytical and industrial instrumentation**
 - Leak detection equipment
 - Spectroscopy equipment
- **Mass flow controllers**
- **Telecommunication systems**
- **Environmental climate controls**

Honeywell

AWM700 Series 200 LPM Airflow Sensor

AWM700 Series Key Selling Points:

- Honeywell Sensing and Control is the recognized industry leader in mass airflow sensing using patented microbridge technology.
- This high flow solid state product fills a significant gap in the ventilator market today. Present ventilator companies are using technologies such as hot film anemometers, variable orifice pressure sensors, acoustic sensors and coiled wire.
- The AWM720P1 leverages existing silicon piezoresistive technology and base components similar to the compact AWM40000 product line.
- This sensor is specifically designed to meet requirements expressed by those in the medical ventilator market and should fit into most applications with little or no modifications.

Honeywell

AWM700 Series 200 LPM Airflow Sensor

Ventilator application using Honeywell's 200 LPM airflow sensor technology

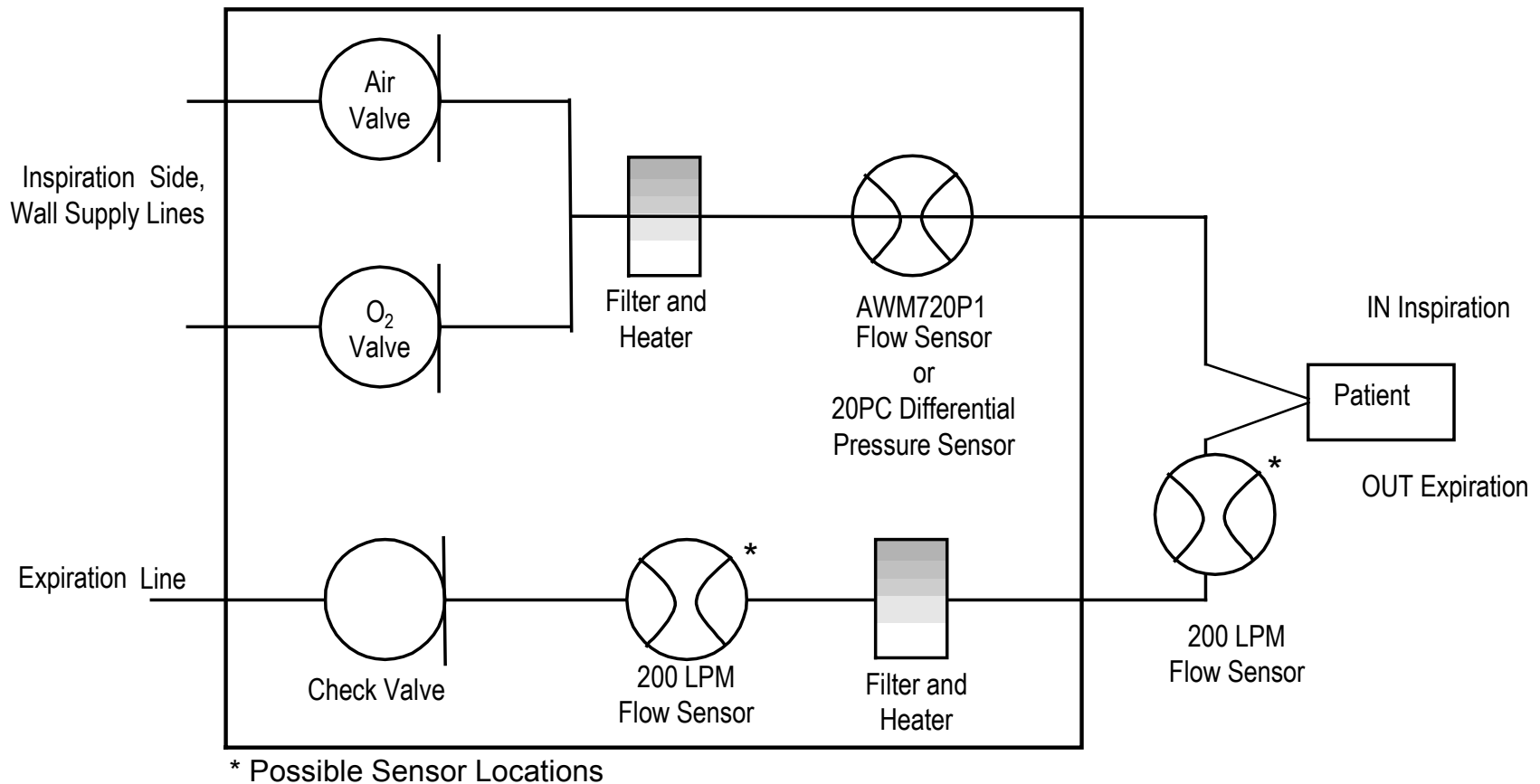

Honeywell