

Installation Instructions for the MICRO SWITCH Global Limit Switches (GLS MIN-DIN Series)
Instrucciones de instalación para los MICRO SWITCH interruptores limite global (serie GLS MIN-DIN)
Einbauanweisungen für den MICRO SWITCH Global Endschalter (Serie GLS MIN-DIN)
Instructions d'installation du MICRO SWITCH fin de course mondiales (série GLS MIN-DIN)
Istruzioni per l'installazione del MICRO SWITCH finecorsa globali (Serie GLS MIN-DIN)
Instruções de Instalação para o MICRO SWITCH de limite global (Série GLS MIN-DIN)
MICRO SWITCH 全球限位开关 (GLS MIN-DIN 系列) 安装指南

⚠ WARNING

IMPROPER INSTALLATION

- Consult with local safety agencies and their requirements when designing a machine-control link, interface, and all control elements that affect safety.
- Strictly adhere to all installation instructions.

Failure to comply with these instructions could result in death or serious injury.

MOUNT, WIRE, AND SEAL THE SWITCH

⚠ WARNING

IMPROPER OPERATION

- Ensure switch actuator achieves sufficient travel for positive opening of normally closed (NC) contacts to occur.

Failure to comply with these instructions could result in death or serious injury.

1. Refer to:
 - Page 5 for adjustments
 - Pages 8 to 12 for specific travel distances for each switch code and specifications
 - Page 5 for proper application of limit switches
 - Page 13 to 18 for switch mounting dimensions
2. Perform adjustments (if desired):
 - Head orientation (Figure 1, page 5)
 - Actuation direction (Figure 2, page 5)
 - Side rotary switches with 36 drive lever positions (Figure 3, page 5):
3. Mount switch at top corners of switch using two M4 or #8 screws. For GLD products torque screws to 2,7 Nm to 3,4 Nm [24 in-lb to 30 in-lb]. For GLC & GLE products torque screws to 3,1 Nm to 3,7 Nm [27 in-lb to 33 in-lb].
4. Remove screws on cover plate.
5. Connect stranded wire (0,75 mm² to 2,3 mm², 18-14 AWG) or solid wire (0,75 mm² to 1,5 mm², 18-16 AWG) to contact block terminals (use 90 °C wire when ambient temperature is over 75 °C). Torque switch terminal screws to 0,8 Nm to 1,0 Nm [7 in-lb to 9 in-lb].
6. Seal conduit opening according to instructions in PK 80112.
7. Reassemble cover plate, and torque cover screws to 0,5 Nm [4,4 in-lb].

⚠ ADVERTENCIA

INSTALACIÓN INCORRECTA

- Consulte las normas de seguridad y sus requisitos al realizar el diseño del enlace de control de una máquina, la interfaz, y los elementos de control que afecten a la seguridad.
- Siga estrictamente todas las instrucciones para la instalación.

El incumplimiento de estas recomendaciones puede ocasionar lesiones graves o peligro de muerte.

MONTAJE, CABLEADO Y SELLADO DEL INTERRUPTOR

⚠ ADVERTENCIA

FUNCIONAMIENTO INCORRECTO

- Asegúrese que el actuador del interruptor tenga la suficiente carrera para que se produzca la apertura positiva de los contactos normalmente cerrados (NC).

El incumplimiento de estas recomendaciones puede ocasionar lesiones graves o peligro de muerte.

1. Consulte:
 - Página 5 para obtener información sobre ajustes
 - Páginas 8 a 12 para obtener las distancias específicas de carrera para cada código de interruptor y especificaciones
 - Página 5 para obtener información sobre la aplicación correcta de los interruptores de final de carrera
 - Página 13 a 18 para obtener las dimensiones de montaje del interruptor
2. Realice ajustes (si lo desea):
 - Orientación del cabezal (Figura 1, página 5)
 - Dirección del accionamiento (Figura 2, página 5)
 - Interruptores de rotación lateral con 36 posiciones de la palanca de impulsión (Figura 3, página 5):
3. Monte el interruptor colocando dos tornillos M4 o N.º 8 en sus ángulos superiores. Para los productos GLD, ajuste los tornillos empleando un torque de 2,7 Nm a 3,4 Nm [de 24 in-lb a 30 in-lb]. Para los productos GLC y GLE, ajuste los tornillos empleando un torque de 3,1 Nm a 3,7 Nm [de 27 in-lb a 33 in-lb].
4. Retire los tornillos de la tapa.
5. Conecte cable trenzado (de 0,75 mm² a 2,3 mm², 18-14 AWG) o sólido (de 0,75 mm² a 1,5 mm², 18-16 AWG) en los terminales del bloque de contactos (utilice cable de 90 °C cuando la temperatura ambiente es mayor de 75 °C). Ajuste los tornillos empleando un torque de 0,8 Nm a 1,0 Nm [de 7 in-lb a 9 in-lb].
6. Selle la entrada del conducto según las instrucciones incluidas en PK 80112.
7. Vuelva a montar la tapa y ajuste empleando un torque de 0,5 Nm [4,4 in-lb].

⚠️ WARNUNG **UNSACHGEMÄSSER EINBAU**

- Beraten Sie sich mit den zuständigen Sicherheitsbehörden beim Entwurf von Verbindungen zu Maschinensteuerungen, Schnittstellen und sämtlichen Steuerelementen, welche die Sicherheit betreffen.
- Halten Sie sich genau an die Einbau-Anweisungen.

Das Nichtbeachten dieser Anweisungen könnte zum Tod oder zu schweren Verletzungen führen.

SCHALTER MONTIEREN, ANSCHLIESSEN UND ABDICHTEN

⚠️ WARNUNG **UNSACHGEMÄSSER BETRIEB**

- Sicherstellen, daß der Betätiger genügend Laufweg hat, um die Öffnerkontakte (NC) zwangszuöffnen.

Das Nichtbeachten dieser Anweisungen könnte zum Tod oder zu schweren Verletzungen führen.

1. Weitere Informationen:
 - Einstellungen auf Seite 5
 - Spezifische Laufwege für jeden Schaltercode und Spezifikationen auf Seiten 8 bis 12
 - Sachgemäße Anwendung von Positionsschaltern auf Seite 5
 - Schaltermontage-Abmessungen auf Seiten 13 bis 18
2. Einstellungen vornehmen (falls gewünscht):
 - Ausrichtung des Kopfes (Abbildung 1, Seite 5)
 - Betätigungsrichtung (Abbildung 2, Seite 5)
 - Schalter mit seitlichem Schwenkhebel mit 36 Antriebshelpositionen (Abbildung 3, Seite 5):
3. Den Schalter an den oberen Ecken mit Hilfe von zwei M4-Schrauben oder Schrauben Nr. 8 montieren. Für GLD-Produkte Schrauben auf 2,7 Nm bis 3,4 Nm [24 in-lb bis 30 in-lb] anziehen. Für GLC & GLE-Produkte Schrauben auf 3,1 Nm bis 3,7 Nm [27 in-lb bis 33 in-lb] anziehen.
4. Die Schrauben auf der Deckplatte entfernen.
5. Den Litzendraht (0,75 mm² ... 2,3 mm², 18 ... 14 AWG) oder Draht (0,75 mm² ... 1,5 mm², 18 ... 16 AWG) an die Sicherheitskontaktblock-Klemmleisten anschließen (wärmebeständige Aderleitung 90 °C verwenden, wenn die Umgebungstemperatur über 75 °C liegt). Klemmenleistenschrauben auf 0,8 Nm bis 1,0 Nm [7 in-lb bis 9 in-lb] anziehen.
6. Die Kabeleinführung entsprechend den Anweisungen in PK 80112 versiegeln.
7. Bringen Sie die Abdeckplatte wieder an, und schrauben Sie diese mit einem Anzugsmoment von 0,5 Nm [4,4 in-lb] fest.

⚠️ AVERTISSEMENT **INSTALLATION INCORRECTE**

- Faites appel à des emperatu locaux de sécurité et prenez en compte leurs exigences lorsque vous concevez une liaison de commande ou interface de machine, ou tout autre dispositif de commande mettant en jeu la sécurité.
- Respectez scrupuleusement l'ensemble des instructions d'installation.

L'inobservation de ces instructions peut entraîner la mort ou de graves blessures.

MONTEZ, CABLEZ ET ETANCHEIFIEZ L'INTERRUPTEUR

⚠️ AVERTISSEMENT **MAUVAIS FONCTIONNEMENT**

- Veillez à ce que l'actionneur de l'interrupteur parcourt une course suffisante afin de permettre une ouverture positive des contacts normalement fermés (NF).

L'inobservation de ces instructions peut entraîner la mort ou de graves blessures.

1. Consultez :
 - la page 5 pour les réglages.
 - les pages 8 à 12 pour connaître les longueurs de courses pour chaque code d'interrupteur et les caractéristiques techniques.
 - la page 5 pour une utilisation correcte des interrupteurs de fin de course.
 - les pages 13 à 18 pour les cotes de montage de l'interrupteur.
2. Effectuez les réglages (le cas échéant) :
 - Orientation de la tête (figure 1, page 5)
 - Sens de commutation (figure 2, page 5)
 - Interrupteurs à rotation latérale avec 36 positions de leviers (figure 3, page 5) :
3. Montez l'interrupteur en vissant deux vis M4 ou n° 8 sur sa partie supérieure. Pour les produits GLD, exercez sur les vis un couple de 2,7 Nm à 3,4 Nm [24 in-lb à 30 in-lb]. Pour les produits GLC et GLE, exercez sur les vis un couple de 3,1 Nm à 3,7 Nm [27 in-lb à 33 in-lb].
4. Retirez les vis du couvercle.
5. Connectez du fil souple (0,75 mm² à 2,3 mm², 18 à 14 AWG) ou rigide (0,75 mm² à 1,5 mm², 18 à 16 AWG) aux bornes du bloc de contacts (utilisez du fil 90 C lorsque la température ambiante est supérieure à 75 °C). Exercez sur les vis des bornes de l'interrupteur un couple de 0,8 Nm à 1,0 Nm [7 in-lb à 9 in-lb].
6. Réalisez l'étanchéité de l'ouverture du conduit conformément aux instructions données en PK 80112.
7. Remplacez le couvercle et serrez les vis avec un couple de 0,5 Nm [4,4 in-lb].

⚠ ATTENZIONE **INSTALLAZIONE SCORRETTA**

- Consultare gli enti locali in materia di antinfortunistica e le rispettive normative nel momento in cui ci si avvia alla progettazione di un qualsiasi collegamento controllo macchina, o di un'interfaccia, o di tutti gli elementi di controllo che possano influire sulla sicurezza.
- Attenersi rigorosamente a tutte le istruzioni relative all'installazione.

L'inosservanza di tali istruzioni può essere causa di gravi lesioni, con conseguenze addirittura fatali.

MONTARE, CABLARE E SIGILLARE L'INTERRUTTORE

⚠ ATTENZIONE **FUNZIONAMENTO SCORRETTO**

- Accertarsi che la corsa dell'attuatore dell'interruttore sia sufficiente a consentire l'apertura forzata dei contatti normalmente chiusi (NC).

L'inosservanza di tali istruzioni può essere causa di gravi lesioni, con conseguenze addirittura fatali.

1. Consultare:
 - Pagina 5, per le regolazioni
 - Pagine da 8 a 12, per gli specifici valori relativi a ciascun codice di interruttore e per i dati tecnici
 - Pagina 5, per il corretto uso degli interruttori finecorsa
 - Pagine da 13 a 18, per le dimensioni di montaggio dell'interruttore
2. Eseguire le regolazioni (in base alle esigenze):
 - Orientamento testa (Figura 1, pagina 5)
 - Direzione di attuazione (Figura 2, pagina 5)
 - Interruttori a rotazione laterale con leve di azionamento a 36 posizioni (Figura 3, pagina 5):
3. Montare l'interruttore negli angoli superiori dell'interruttore mediante due viti M4 o #8. Per i prodotti GLD, serrare le viti con una coppia compresa tra 2,7 Nm e 3,4 Nm [da 24 in-lb a 30 in-lb]. Per i prodotti GLC e GLE, serrare le viti con una coppia compresa tra 3,1 Nm e 3,7 Nm [da 27 in-lb a 33 in-lb].
4. Rimuovere le viti dalla piastra di copertura.
5. Collegare cavi flessibili (da 0,75 mm² a 2,3 mm², 18-14 AWG) o cavi rigidi (da 0,75 mm² a 1,5 mm², 18-16 AWG) ai morsetti dei connettori (se la temperatura ambiente supera i 75 °C, utilizzare cavi che hanno una temperatura di esercizio pari a 90 °C). Serrare le viti dei morsetti con una coppia compresa tra 0,8 Nm e 1,0 Nm [da 7 in-lb a 9 in-lb].
6. Sigillare l'apertura pressacavo in base alle istruzioni riportate in PK 80112.
7. Rimontare il coperchio e serrare le viti con una coppia di 0,5 Nm [4,4 in-lb].

⚠ ADVERTÊNCIA **INSTALAÇÃO INCORRETA**

- Consulte as agências de segurança local e seus requisitos ao projetar unidades de conexão ou interface para controle de máquinas, bem como todos os elementos de controle que possam afetar a segurança
- Obedeça rigorosamente todas as instruções de segurança.

Desobediência a essas instruções pode resultar em morte ou ferimentos graves.

MONTAGEM, FIAÇÃO E VEDAÇÃO DO SWITCH

⚠ ADVERTÊNCIA **INSTALAÇÃO INCORRETA**

- Certifique-se de que o atuador do switch atinja um percurso suficiente para que ocorra a abertura positiva de contatos normalmente fechados (NC, normally closed).

Desobediência a essas instruções pode resultar em morte ou ferimentos graves.

1. Consulte:
 - A página 5 para ajustes.
 - As páginas 8 e 12 para distâncias de percurso para cada código de chave e especificações
 - A página 5 para saber a aplicação correta das chaves de fim de curso
 - As páginas 13 a 18 para dimensões de instalação do switch
2. Faça os ajustes necessários (se desejado):
 - Orientação do cabeçote (Figura 1, página 5)
 - Direção de atuação (Figura 2, página 5)
 - Chaves laterais giratórias com 36 posições da alavanca de acionamento (Figura 3, página 5):
3. Instale dois parafusos M4 ou N° 8 na parte superior para montar a chave. Para produtos GLD, aperte os parafusos com torque de 2,7 a 3,4 Nm [24 a 30 lb-pol.]. Para produtos GLC e GLE, aperte os parafusos com torque de 3,1 a 3,7 Nm [27 a 33 lb-pol.].
4. Remova os parafusos da tampa de cobertura.
5. Conecte o fio desfiado (0,75 mm² a 2,3 mm², 18 AWG-14 AWG) ou fio sólido (0,75 mm² a 1,5 mm², 18 AWG-16 AWG) aos terminais do conector (use fiação para até 90 °C quando a temperatura ambiente for superior a 75 °C.). Aperte os parafusos de terminal com torque de 0,8 a 1,0 Nm [7 a 9 lb-pol.].
6. Vede as aberturas do conduíte de acordo com as instruções encontradas no PK 80112.
7. Monte novamente a tampa de cobertura e aperte os parafusos com torque de 0,5 Nm [4,4 lb-pol.].

Installation Instructions for MICRO SWITCH GLS Min-Din Limit Switches

ISSUE 10 **81521**

⚠ 警告

安装不当

- 设计机器控制链接、接口以及所有影响安全的控制元件时，请咨询当地安全机构，了解相关要求。
- 严格遵守安装指南。

如果不遵守以上说明，则有可能造成死亡或重伤。

开关的安装、接线和密封

⚠ 警告

操作不当

- 确保开关驱动器有足够的移动行程，能让常闭 (NC) 触点正极开启。

如果不遵守以上说明，则有可能造成死亡或重伤。

1. 请参阅：
 - 第 5 页，了解如何进行调节
 - 第 8 至 12 页，了解各开关编码对应的具体移动行程和规格
 - 第 5 页，了解限位开关的正确应用
 - 第 13 至 18 页，了解开关的安装尺寸
2. 根据需要进行调节：
 - 操作头方向（第 5 页“图 1”）
 - 动作方向（第 5 页“图 2”）
 - 侧旋转开关，带 36 个驱动杆位置（第 5 页“图 3”）：
3. 用 M4 或 #8 螺钉安装开关顶部的各角。对于 GLD 产品，向螺钉施加 2.7 - 3.4 Nm [24 - 30 in-lb] 的扭动力。对于 GLC 和 GLE 产品，向螺钉施加 3.1 - 3.7 Nm [27 - 33 in-lb] 的扭动力。
4. 拆下盖板上的螺钉。
5. 将绞合线（0.75 mm² 至 2.3 mm²，18-14 AWG）或单股线（0.75 mm² 至 1.5 mm²，18-16 AWG）连接至接触块端子（环境温度超过 75 °C 时，使用 90 °C 的线）。向开关端子螺钉施加 0.8 - 1.0 Nm [7 - 9 in-lb] 的扭动力。
6. 按照 PK 80112 中的说明密封导线孔。
7. 重新装上盖板，向盖板上的螺钉施加 0.5 Nm [4.4 in-lb] 的扭动力。

Installation Instructions for MICRO SWITCH GLS Min-Din Limit Switches

ISSUE 10 **81521**

**FIELD ADJUSTABLE HEAD
FIELD VERSTELLBAREM KOPF
CAMPO TESTA REGOLABILE**

**CAMPO DE CABEÇA AJUSTABLE
TÊTE DE CHAMP RÉGLABLE
CABEÇA CAMPO AJUSTÁVE**

现场可调节操作头

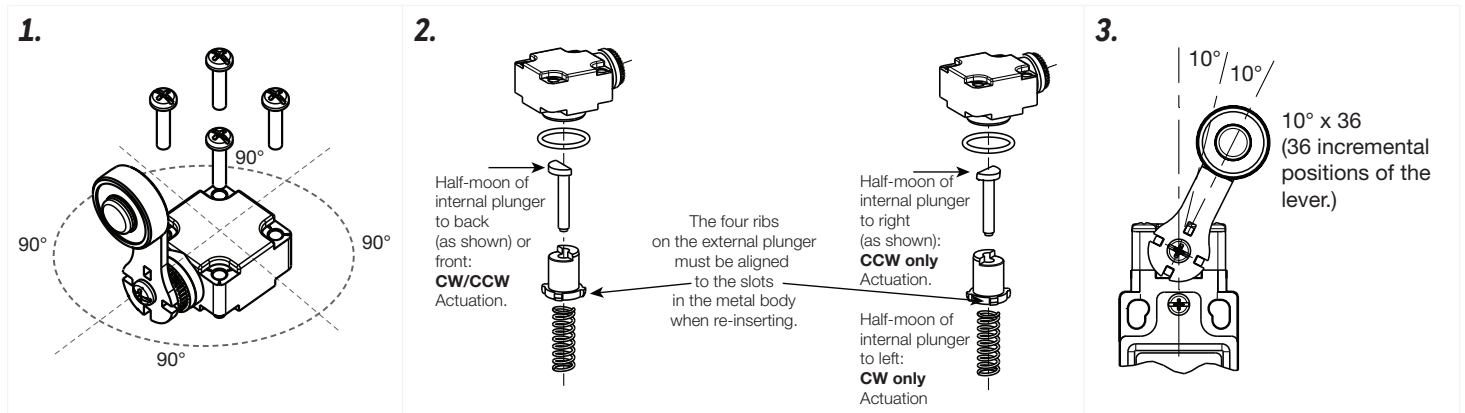

**OPERATION REQUIREMENTS
ANFORDERUNGEN AN DEN BETRIEB
REQUISITI PER L'ESERCIZIO**

**REQUISITOS DE FUNCIONAMIENTO
EXIGENCES DE FONCTIONNEMENT
REQUISITOS DE OPERAÇÃO**

操作要求

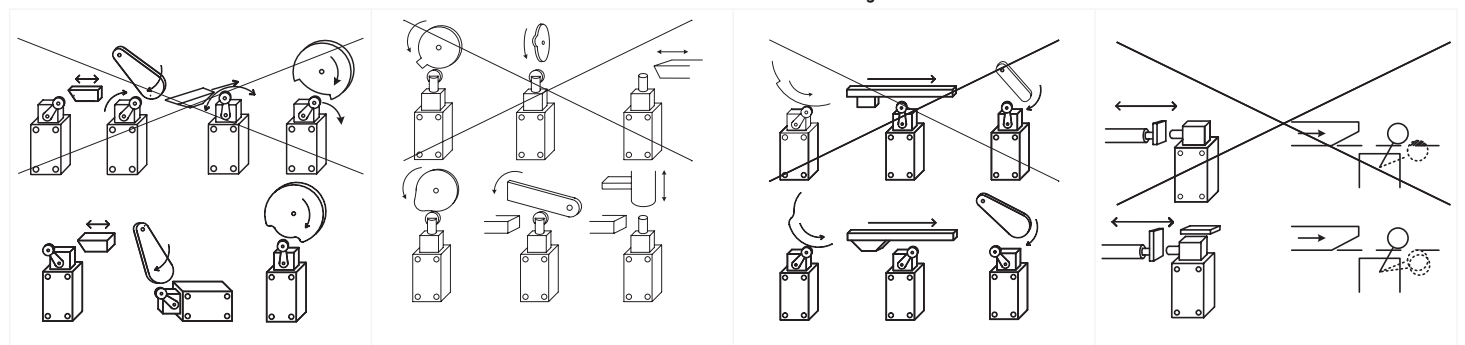

**TERMS
BEDINGUNGEN
TARIFFE**

**CONDICIONES
TERMES
CONDIÇÕES**

术语

Contact Closed	Contacto cerrado	Kontakt geschlossen	Contact fermé	Contatto chiuso	Contato Fechado	触点已闭合
Contact Open	Contacto abierto	Kontakt offen	Contact ouvert	Contatto aperto	Contato Aberto	触点已开启
Differential Travel	Carrera diferencial	Differenzwinkel	Course différentielle	Corsa differenziale	Percurso Diferencial	差动行程
Free Position	Posición libre	Freistellung	Position libre	Posizione libera	Posição Livre	自由位置
Operating Position 1	Posición de funcionamiento 1	Schaltpunkt 1	Position de commutation 1	Posizione di funzionamento 1	Posição de Operação 1	工作位置 1
Positive Opening 1 to IEC 947-5-1	Apertura positiva 1 según IEC 947-5-1	Zwangsöffnung 1 gemäß IEC 947-5-1	Ouverture positive 1 selon CEI 947-5-1	Apertura forzata 1 Conforme alla norma IEC 947-5-1	Abertura Positiva 1 para IEC 947-5-1	正极开启 1 至 IEC 947-5-1
Differential Travel 1	Carrera diferencial 1	Differenzweg 1	Course différentielle 1	Corsa differenziale 1	Percurso Diferencial 1	差动行程 1
Over Travel	Sobrecarrera	Nachlaufweg	Surcourse	Oltre corsa	Sobrepercurso	超程
Maximum Operating Force	Fuerza de funcionamiento máxima	Maximale Betätigungskraft	Force de commutation maximum	Forza massima di intervento	Força Máxima de Operação	最大操纵力
Maximum Disconnect Force	Fuerza de desconexión máxima	Maximale Öffnungskraft	Force de déconnexion maximum	Forza massima di scollamento	Força Máxima de Desconexão	最大切断力

Installation Instructions for MICRO SWITCH GLS Min-Din Limit Switches

ISSUE 10 **81521**

Designation and Utilization Category		Rated Operational Current Ie (A) at Rated Operational Voltage Ue (V)					
		24 V	120 V	240 V	380 V	480 V	600 V
ac15	A300	–	6 A	3 A	–	–	–
ac15	A600	–	6 A	3 A	1.9 A	1.5 A	1.2 A
dc13	Q300	2.8 A	0.55 A	0.27 A	–	–	–
Rated thermal current (Ith)		10 A					
Sealing		GLC/GLE: IP66; NEMA 1, 4, 12, 13 GLD: IP67; NEMA 1, 4X, 12, 13 (4X indoor use only)					
Rated impulse withstand (Uimp)		2500 V					
Pollution degree		3					
Rated insulation voltage (Ui)		300 V, 600 V					
Operating temperature range		-40 °C to 85 °C [-40 °F to 185 °F]					
Short-circuit protective device (type/maximum rating)		Class J fuse (10 A/600 V)					
Expected mechanical life		up to 10,000,000 operations					
Conditional short-circuit current		1000 A					
Electrical rating for gold-plated contacts		10 µA to 100 mA, 1 Vac/Vdc to 50 Vac/Vdc					

- Low Voltage Directive 2006/95/EC
- Machinery Directive 2006/42/EC only as directives relate to the components being used in a safety function
- IEC/EN 60947-5-1

Designation and utilization category	Categoría de designación y utilización	Bezeichnung und Verwendungskategorie	
Rated operational current Ie (A) at rated operational voltage Ue (V)	Corriente operativa nominal Ie (A) a voltaje operativo nominal Ue (V)	Nominaler Betriebsstrom Ie (A) bei nominaler Betriebsspannung Ue (V)	
Rated thermal current (Ith)	Corriente térmica nominal (Ith)	Nominaler thermischer Strom (Ith)	
Rated impulse withstand (Uimp)	Resistencia de impulso nominal (Uimp)	Nominale Impulsspannung (Uimp)	
Rated insulation voltage (Ui)	Voltaje de aislamiento nominal (Ui)	Nominale Isolationsspannung (Ui)	
Short-circuit protective device (type/maximum rating)	Dispositivo de protección contra cortocircuito (tipo/valor nominal)	Kurzschluß-Schutzeinrichtung (Typ/Maximalleistung)	
Conditional short-circuit current	Corriente condicional de cortocircuito	Bedingter Kurzschlußstrom	
Electrical rating for gold-plated contacts	Clasificación eléctrica para contactos bañados en oro	Schaltvermögen von vergoldeten Kontakten	
Sealing	Sellado	Schutzart	
Pollution degree	Nivel de contaminación	Emissionsgrad	
Operating temperature range	Limites de temperatura de funcionamiento	Betriebstemperaturbereich	
Expected mechanical life	Vida mecánica esperada	Erwartete mechanische Lebensdauer	
Operations	Operaciones	Schaltspiele	
Complies with:	Cumple con:	Entspricht:	
• Low Voltage Directive 2006/95/EC	• Directiva de bajo voltaje 2006/95/EEC	• Niederspannungs-Richtlinie 2006/95/EG	
• Machinery Directive 2006/42/EC only as the directives relate to the components being used in a safety function.	• Directiva de maquinarias 2006/42/EEC solo en lo que se refiere a componentes que se utilizan en una función de seguridad.	• Maschinen-Richtlinie 2006/42/EG, soweit sich diese auf die Komponenten bezieht, die als Sicherheitsvorrichtungen verwendet werden.	
Désignation et catégorie d'utilisation	Denominazione e categoria d'impiego	Categoria de designação e utilização	体系及应用类别
Courant de fonctionnement nominal Ie (A) à la tension de fonctionnement nominale Ue(V)	Corrente nominale di esercizio Ie (A) alla tensione nominale di esercizio Ue (V)	Corrente operacional nominal Ie (A) na tensão operacional nominal Ue (V)	额定工作电压 Ue (V) 下的额定工作电流 Ie (A)
Courant thermique nominal (Ith)	Corrente termica nominale (Ith)	Corrente térmica nominal (Ith)	额定热电流 (Ith)
Tension nominale de tenue au choc (Uimp)	Resistenza agli impulsi nominale (Uimp)	Resistência nominal ao impulso (Uimp)	额定冲击耐受 (Uimp)
Tension d'isolement nominale (Ui)	Tensione di isolamento nominale (Ui)	Tensão de isolamento nominal (Ui)	额定绝缘电压 (Ui)
Dispositif de protection contre les courts-circuits (type/valeur nominale maximum)	Dispositivo di protezione per cortocircuito (valore nominale tipico/massimo)	Dispositivo protetor contra curto-circuito (tipo/nominal máxima)	短路保护器件 (类型/最大等级)
Courant de court-circuit conditionnel	Corrente di cortocircuito condizionale	Corrente condicional de curto-circuito	限制短路电流
Caractéristiques électriques de contacts plaqués or	Classificazione elettrica per contatti placcati oro	Classificações elétricas para contatos banhados a ouro	镀金触点电气额定值
Étanchéité	Grado di protezione	Vedação	密封
Indice de pollution	Grado di inquinamento	Grau de poluição	污染程度
Gamme de températures de fonctionnement	Temperature di esercizio	Faixa de temperaturas de operação	工作温度范围
Durée mécanique prévue	Durata meccanica prevista	Vida mecânica esperada	预期机械寿命
Utilisation	Operazioni	Operações	操作
Conforme à:	Conforme con:	Em conformidade com:	符合:
• Directive Basse tension 2006/95/CEE	• Direttiva Bassa tensione 2006/95/CEE	• Diretiva de baixa tensão 2006/95/EEC	• 2006/95/EC 低电压指令
• Directive Machine 2006/42/EEC limitée à ce qui concerne les composants utilisés dans une fonction de sécurité.	• Direttiva macchine 2006/42/CEE solo nella misura in cui la direttiva fa riferimento ai componenti da utilizzare con funzioni di sicurezza.	• Diretiva de maquinário 2006/42/EEC somente no que se refere aos componentes usados em função de segurança.	• 机械指令 2006/42/EC, 仅限与安全功能中使用的元件相关的指令。

Installation Instructions for MICRO SWITCH GLS Min-Din Limit Switches

ISSUE 10 **81521**

Figure 4. Reading Operating Specifications

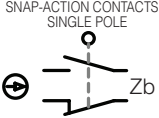
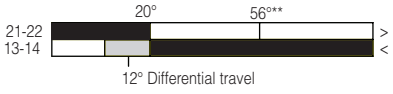
Catalog listing	Contact block diagram	Nominal travels and related terminals 	Operating force max.	Disconnect force, max.	Operating degrees, max.	Operating degrees, min.	Max. operate frequency ops/min
GL**01A GL**07A			9,7 N [2.2 lb]	11,4 N [2.6 lb]	0,85 M/S [33.5 in/S]	8,5 mm/S [0.33 in/S]	250
↑ Catalog Listing Code	↑ Contact Block Diagram Shows the circuit configuration of the internal contact block.	↑ Operating Bar Charts Show the state of the contacts relative to the position of the actuator.	↑	↑	↑	↑	↑ Operating Specifications

PRODUCT NOMENCLATURE

GL Switch Type	C Body	A Conduit	01 Basic Switch	A1A Head/Actuator	L Modification Codes A1A, A1B, A2A, A2B, A4J, A5B, A9A	
GLS Series Global Limit Switch	C Metal, MIN-DIN D Plastic, MIN-DIN E Metal, Pancake	A 1/2-14 NPT B PG 13.5 C 20 mm	01 SPDT snap action 03 SPDT, BBM slow acting 04 SPDT, MBB slow acting 05 DPST, 2NO slow acting 06 DPST, 2NC slow acting 07 SPDT, snap action, gold cont. 24 DPDT, snap action, Body E 32 DPDT, snap action, gold cont. Body E 33 SPDT, BBM slow acting, gold contacts 34 SPDT, MBB slow acting, gold contacts 35 DPST, 2NO slow acting, gold contacts 36 DPST, 2NC slow acting, gold contacts	A1A Side rotary, fixed, 19 x 6 nylon roller A1B Side rotary, fixed, 19 x 6 steel roller A2A Side rotary, adjust., 19 x 6 nylon roller A2B Side rotary, adjust., 19 x 6 steel roller A4J Side rotary, adjust., 140 mm aluminum rod A4L Side rotary, adjust., 200 mm aluminum rod A5A Side rotary, offset, 19 x 6 nylon roller A5B Side rotary, offset, 19 x 6 steel roller A9A Side rotary, conveyor lever B Top pin plunger C Top roller plunger D Top roller lever	E7A Wobble, plastic stick E7B Wobble, coil E7D Wobble, cat whisker F Adj. top roller lever, Ø27,3 x 5 POM roller K8A Cat whisker, 140 mm K8B Cat whisker, 190 mm K8C Wobble, cat whisker A1 Side rotary, fixed, no roller A2 Side rotary, adjustable, no roller A1Y Side rotary, fixed, 50 x 10 rubber roller A2Y Side rotary, adj., 50 x 10 rubber roller	1 CW rotation only 2 CCW rotation only 3 Lever to right 4 Lever to left 5 Lever to mounting surf. for Actuator/Material C 6 Roller perpendicular to mtg. surf. for Actuator/Material D 6 Lever to right, hinge to left

NOTE: not all combinations of model code are available. Please contact your Honeywell provider/representative for assistance.

Installation Instructions for MICRO SWITCH GLS Min-Din Limit Switches

ISSUE 10 **81521**

Figure 5. Head Code: A
Side Rotary Angular Operating Characteristics

Notes:

- Free position, operate point, over travel and pre-travel all to EN 50047
- Operating characteristics apply to counter clockwise (CCW) and clock wise (CW) actuation
- Refer to page 6 for instructions on how to read operating characteristics and specifications
- Contact block terminal designation to EN 50013
- **Tightening torque GLC/GLD: 0,5 Nm [4.4 in-lb] max.**
- **Tightening torque GLE: 0,339 Nm [3 in-lb] max.**

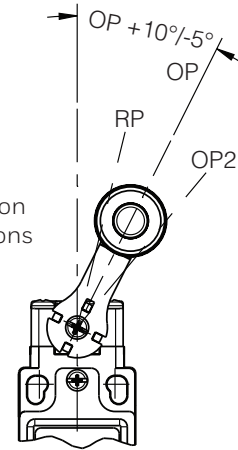

Catalog listing	Contact block diagram	Nominal travels and related terminals ■ Contact Closed □ Contact Open ▨ Diff. Travel **Positive Opening to IEC 947-5-1	Operating torque max.	Disconnect torque, max.	Operating degrees, max.	Operating degrees, min.	Operating velocity, min.	Operating velocity, max.	Max. operate frequency ops/min
GL**01A GL**07A	Snap action 		0,120 Nm [1.1 in-lb]	0,140 Nm [1.3 in-lb]	360°	10°	2,0 mm/s	200 mm/s	250
GL**03A GL**33A	BBM, slow action 		0,110 Nm [1.0 in-lb]	0,160 Nm [1.5 in-lb]	360°	10°	2,0 mm/s	200 mm/s	250
GL**04A GL**34A	MBB, slow action 		0,110 Nm [1.0 in-lb]	0,170 Nm [1.6 in-lb]	360°	10°	2,0 mm/s	200 mm/s	250
GL**05A GL**35A	2 NO, slow action 		0,110 Nm [1.0 in-lb]	0,150 Nm [1.4 in-lb]	360°	10°	2,0 mm/s	200 mm/s	250
GL**06A GL**36A	2 NC, slow action 		0,110 Nm [1.0 in-lb]	0,150 Nm [1.4 in-lb]	360°	10°	2,0 mm/s	200 mm/s	250
GLE*24A GLE*32A	2 NC/2 NO, snap action 		0,165 Nm [1.6 in-lb]	0,165 Nm [1.6 in-lb]		10°	2,0 mm/s	200 mm/s	250

Installation Instructions for MICRO SWITCH GLS Min-Din Limit Switches

ISSUE 10 **81521**

Figure 6. Head Code: B
Pin Plunger Operating Characteristics

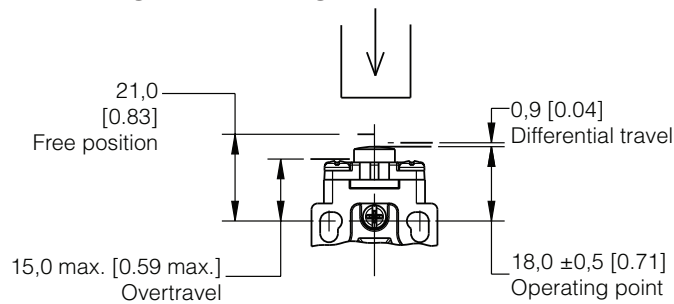

Notes:

- Free position, operate point, overtravel, and pretravel all to EN 50047
- Refer to page 6 for instructions on how to read operating characteristics and specifications
- Contact block terminal designation to EN 50013

Catalog listing	Contact block diagram	Nominal travels and related terminals 	Operating force max.	Disconnect force max.	Operating velocity, max.	Operating velocity, min.	Max. operate frequency ops/min
GL**01B GL**07B	Snap action 		16 N [3.6 lb]	23 N [5.2 lb]	100 mm/S [3.9 in/S]	1,0 mm/S [0.04 in/S]	250
GL**03B GL**33B	BBM, slow action 		14 N [3,2 lb]	24 N [5,4 lb]	100 mm/S [3,9 in/S]	1,0 mm/S [0,04 in/S]	250
GL**04B GL**34B	MBB, slow action 		16 N [3,6 lb]	27 N [6,1 lb]	100 mm/S [3,9 in/S]	1,0 mm/S [0,04 in/S]	250
GL**05B GL**35B	2 NO, slow action 		13 N [2,9 lb]	23 N [5,2 lb]	100 mm/S [3,9 in/S]	1,0 mm/S [0,04 in/S]	250
GL**06B GL**36B	2 NC, slow action 		13 N [2,9 lb]	23 N [5,2 lb]	100 mm/S [3,9 in/S]	1,0 mm/S [0,04 in/S]	250
GLE*24B GLE*32B	2 NC/2 NO, snap action 		13 N [2,9 lb]	24 N [5,4 lb]	100 mm/S [3,9 in/S]	1,0 mm/S [0,04 in/S]	250

Installation Instructions for MICRO SWITCH GLS Min-Din Limit Switches

ISSUE 10 **81521**

Figure 7. Head Code: C
Roller Plunger Operating Characteristics

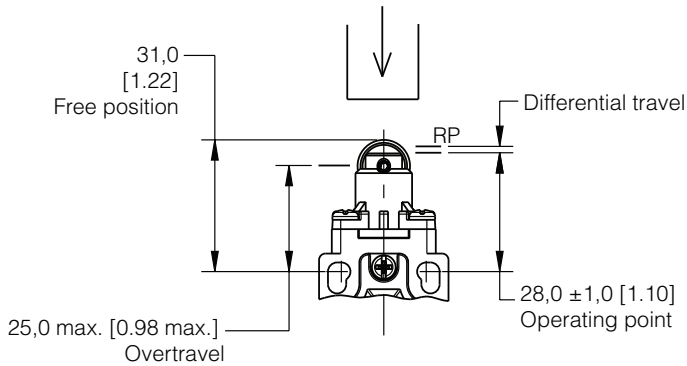

Notes:

- Free position, operate point, overtravel, and pretravel all to EN 50047
- Refer to page 6 for instructions on how to read operating characteristics and specifications
- Contact block terminal designation to EN 50013

Catalog listing	Contact block diagram	Nominal travels and related terminals	Operating force max.	Disconnect force, max.	Operating velocity, max.	Operating velocity, min.	Max. operate frequency ops/min
GL**01C GL**07C	Snap action 		16 N [3.6 lb]	23 N [5.2 lb]	100 mm/S [3.9 in/S]	1,0 mm/S [0.04 in/S]	250
GL**03C GL**33C	BBM, slow action 		14 N [3.2 lb]	24 N [5.4 lb]	100 mm/S [3.9 in/S]	1,0 mm/S [0.04 in/S]	250
GL**04C GL**34C	MBB, slow action 		16 N [3.6 lb]	27 N [6.1 lb]	100 mm/S [3.9 in/S]	1,0 mm/S [0.04 in/S]	250

Catalog listing	Contact block diagram	Nominal travels and related terminals	Operating force max.	Disconnect force, max.	Operating velocity, max.	Operating velocity, min.	Max. operate frequency ops/min
GL**05C GL**35C	2 NO, slow action 		13 N [2.9 lb]	23 N [5.2 lb]	100 mm/S [3.9 in/S]	1,0 mm/S [0.04 in/S]	250
GL**06C GL**36C	2 NC, slow action 		13 N [2.9 lb]	23 N [5.2 lb]	100 mm/S [3.9 in/S]	1,0 mm/S [0.04 in/S]	250
GLE*24C GLE*32C	2 NC/2 NO, snap action 		13 N [2.9 lb]	24 N [5.49 lb]	100 mm/S [3.9 in/S]	1,0 mm/S [0.04 in/S]	250

Installation Instructions for MICRO SWITCH GLS Min-Din Limit Switches

ISSUE 10 **81521**

Figure 8. Head Code: D
Top Roller Lever Operating Characteristics

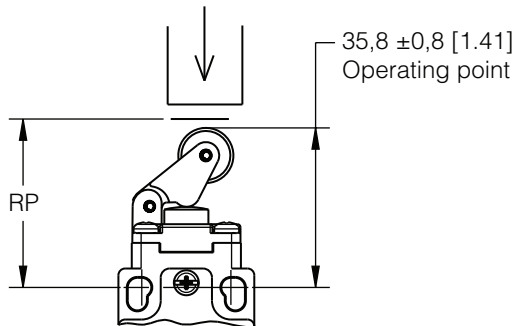

Notes:

- Free position, operate point, overtravel, and pretravel all to EN 50047
- Refer to page 6 for instructions on how to read operating characteristics and specifications
- Contact block terminal designation to EN 50013

Catalog listing	Contact block diagram	Nominal travels and related terminals	Operating force max.	Disconnect force, max.	Operating velocity, max.	Operating velocity, min.	Max. operate frequency ops/min
GL**01D GL**07D	Snap action 		10 N [2.2 lb]	13 N [3.0 lb]	100 mm/s	1,0 mm/s	250
GL**03D GL**33D	BBM, slow action 		9 N [2.0 lb]	16 N [3.6 lb]	100 mm/s	1,0 mm/s	250
GL**04D GL**34D	MBB, slow action 		10 N [2.2 lb]	17 N [3.8 lb]	100 mm/s	1,0 mm/s	250

Catalog listing	Contact block diagram	Nominal travels and related terminals	Operating force max.	Disconnect force, max.	Operating velocity, max.	Operating velocity, min.	Max. operate frequency ops/min
GL**05D GL**35D	2 NO, slow action 		8 N [1.8 lb]	13 N [3.0 lb]	100 mm/s	1,0 mm/s	250
GL**06D GL**36D	2 NC, slow action 		8 N [1.8 lb]	13 N [3.0 lb]	100 mm/s	1,0 mm/s	250
GLE*24D GL*32D	2 NC/ 2 NO, snap action 		3,2 N [0.72 lb]	6,0 N [1.35 lb]	100 mm/s	1,0 mm/s	250

Installation Instructions for MICRO SWITCH GLS Min-Din Limit Switches

ISSUE 10 **81521**

**Figure 9. Head Code: K
Wobble Stick Angular Actuation Operating Char-
acteristics**

Notes:

- Free position, operate point, over travel and pre-travel all to EN 50047
- Refer to page 6 for instructions on how to read operating characteristics and specifications
- Contact block terminal designation to EN 50013

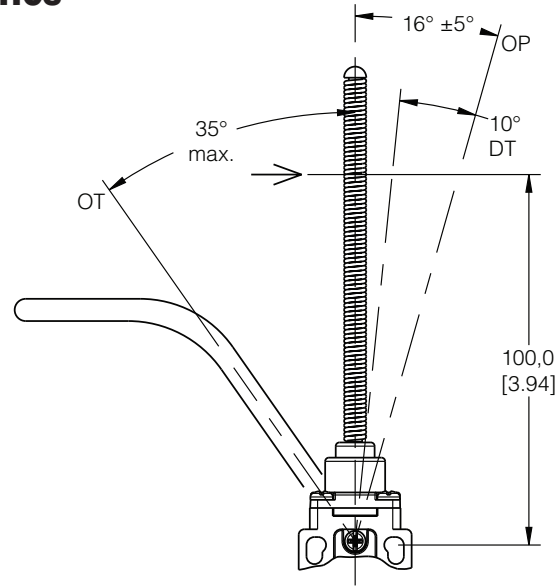

Catalog listing	Contact block diagram	Nominal travels and related terminals **Positive Opening to IEC 947-5-1	Operating torque max.	Operating degrees, max.	Operating degrees, min.	Operating velocity, max.	Operating velocity, min.	Max. operate frequency ops/min
GL**01K GL**07K	Snap action 		1,3 N [0.29 lb]	360°	10°	13 rad/s	0.13 rad/s	100
GL**03K GL**33K	BBM, slow action 		1,1 N [0.25 lb]	360°	10°	13 rad/s	0.13 rad/s	100
GL**04K GL**34K	MBB, slow action 		1,2 N [0.27 lb]	360°	10°	13 rad/s	0.13 rad/s	100
GL**05K GL**35K	2 NO, slow action 		1,1 N [0.25 lb]	360°	10°	13 rad/s	0.13 rad/s	100
GL**06K GL**36K	2 NC, slow action 		1,1 N [0.25 lb]	360°	10°	13 rad/s	0.13 rad/s	100
GLE*24K GLE*32K	2 NC/2 NO, snap action 		1,1 N [0.25 lb]	360°	10°	13 rad/s	0.13 rad/s	100

Installation Instructions for MICRO SWITCH GLS Min-Din Limit Switches

ISSUE 10 **81521**

Figure 1. GLC Side Rotary • A1, A1A, A1B, and A1Y

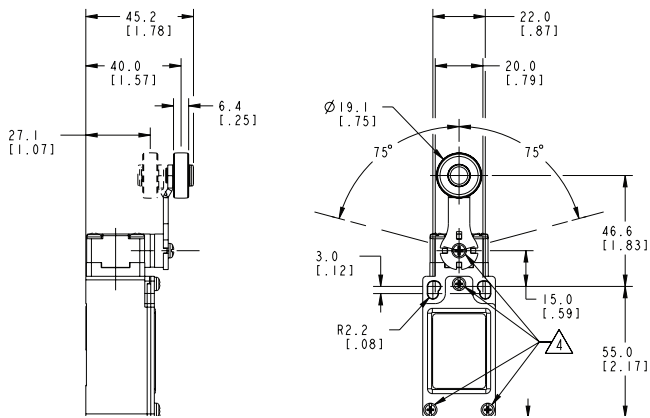

Figure 2. GLC Side Rotary • A2, A2A, A2B, and A2Y

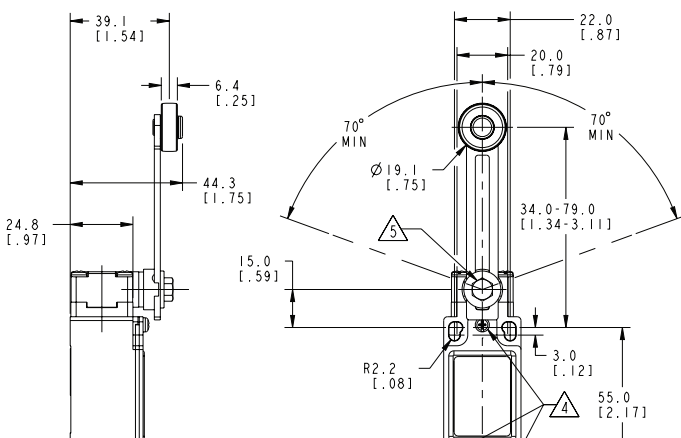

Figure 3. GLC Side Rotary Rod • A4J (140 mm) & A4L (200 mm)

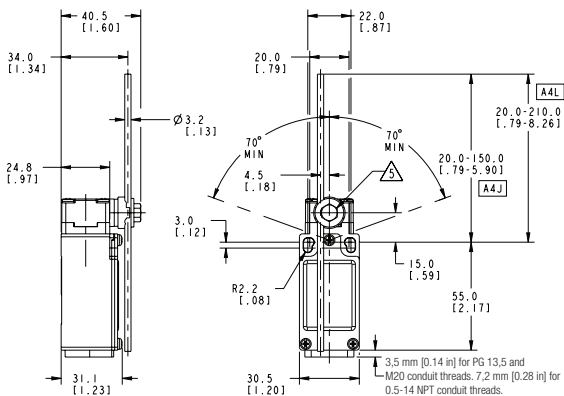

Figure 4. GLC Side Rotary • A5A and A5B

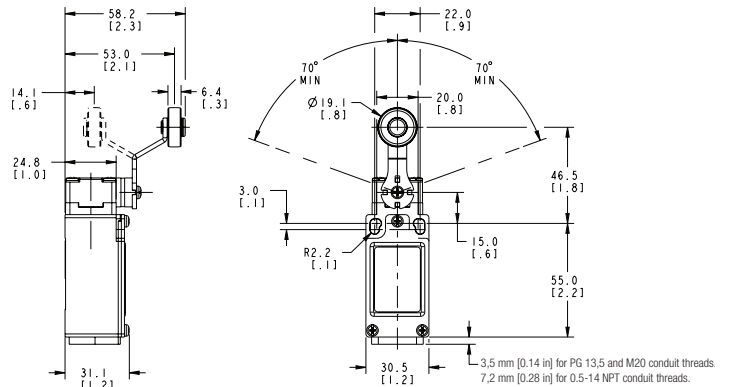

Figure 5. GLC Side Rotary • A9A

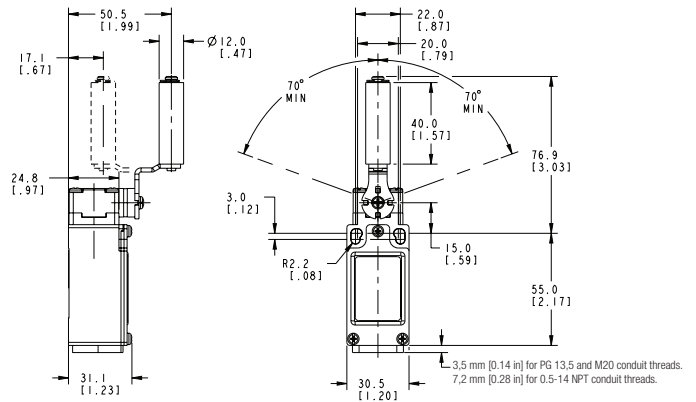
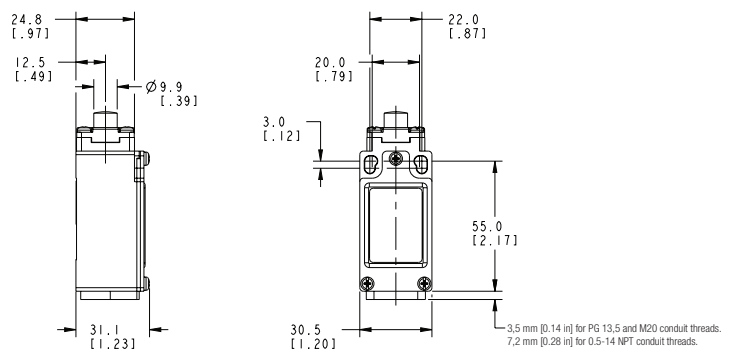

Figure 6. GLC Top Pin Plunger



Installation Instructions for MICRO SWITCH GLS Min-Din Limit Switches

ISSUE 10 **81521**

Figure 7. GLC Top Roller Plunger

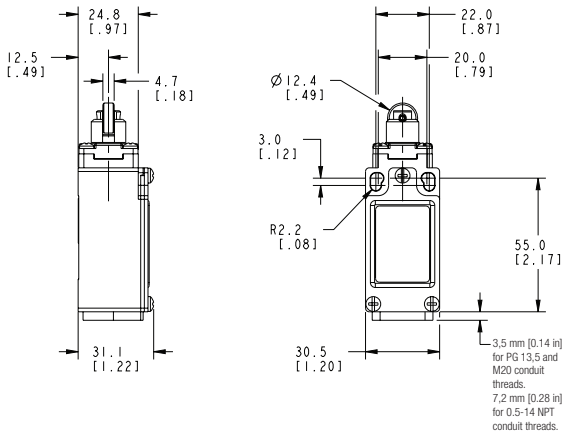

Figure 9. GLC Wobble • E7B

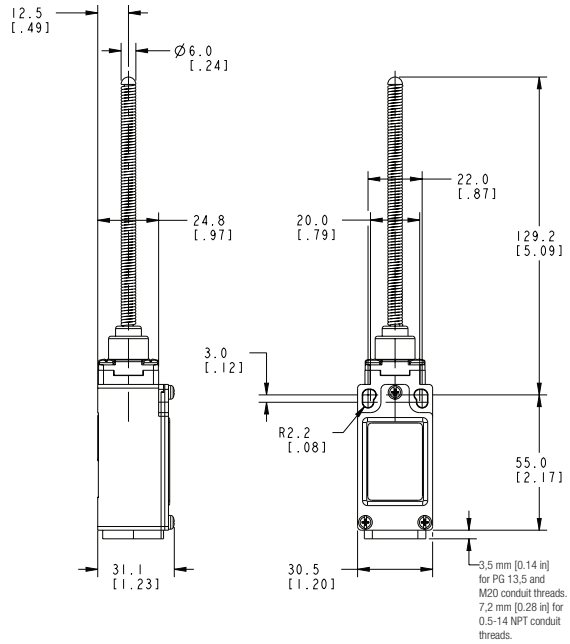

Figure 8. GLC Top Roller Arm

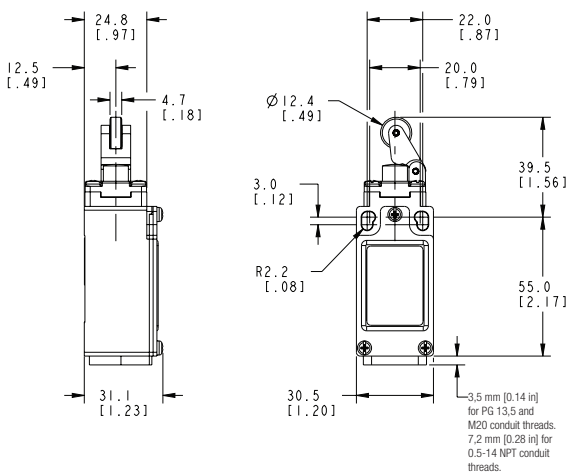

Figure 10. GLC Wobble • K8A/K8B

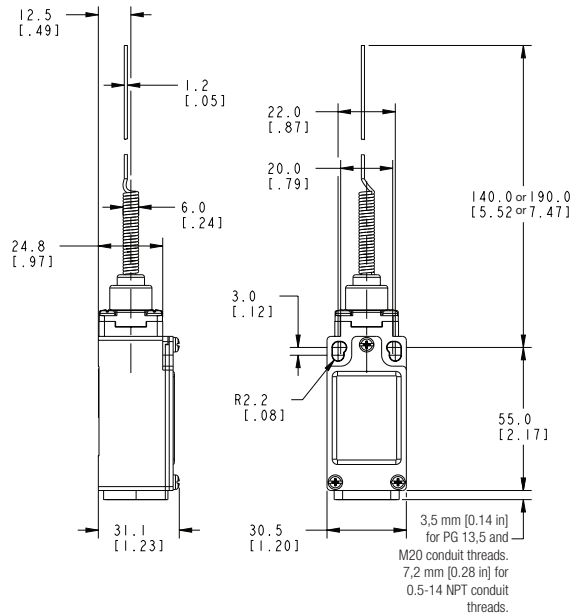
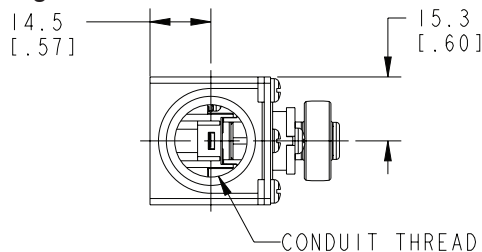

Figure 11. GLC Conduit



Installation Instructions for MICRO SWITCH GLS Min-Din Limit Switches

ISSUE 10 **81521**

Figure 12. GLD Side Rotary • A1, A1A, A1B, and A1Y

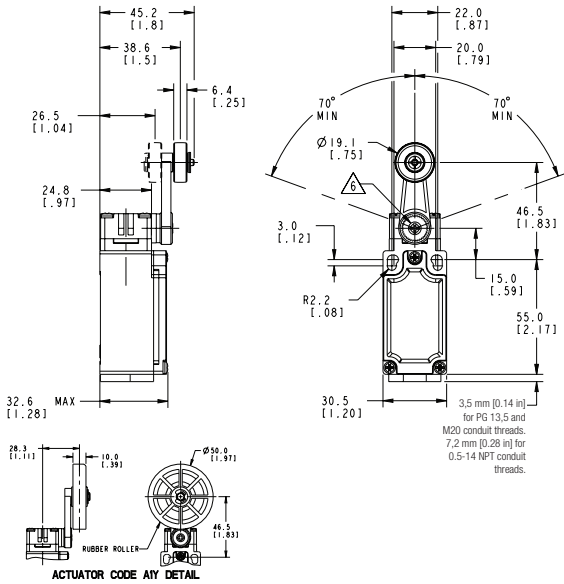

Figure 13. GLD Side Rotary • A2, A2A, A2B, and A2Y

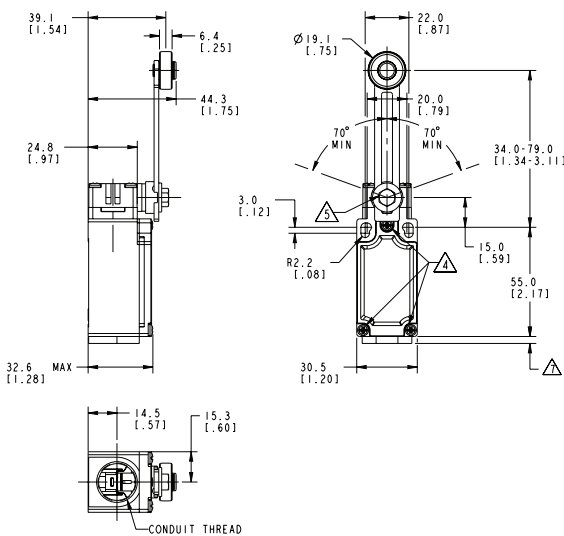

Figure 14. GLD Side Rotary Rod • A4J (140 mm) & A4L (200 mm)

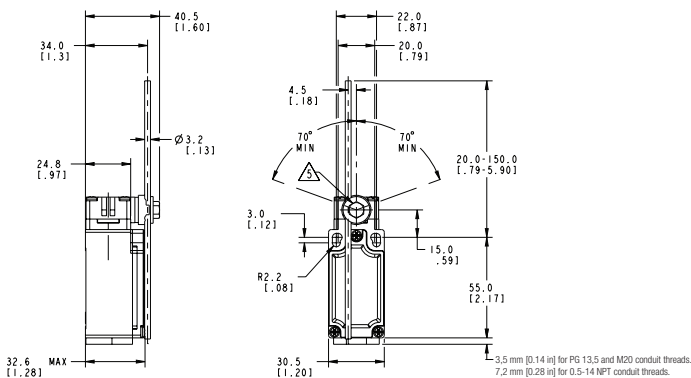

Figure 15. GLD Side Rotary • A5A and A5B

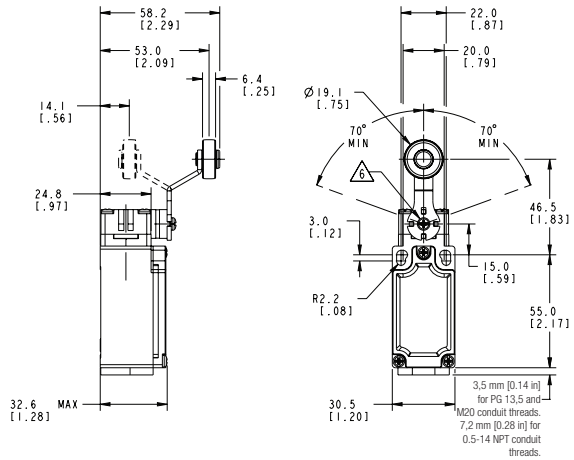

Figure 16. GLD Side Rotary • A9A

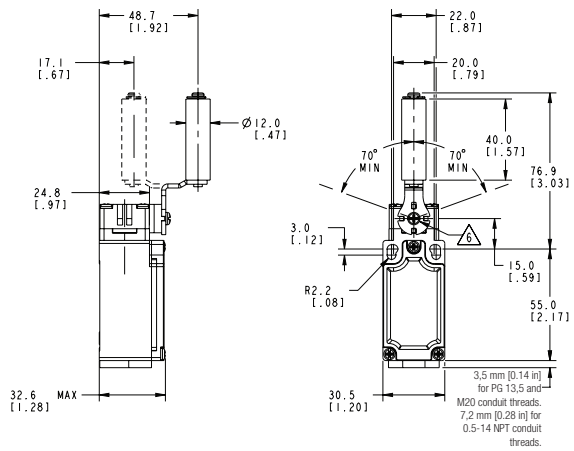
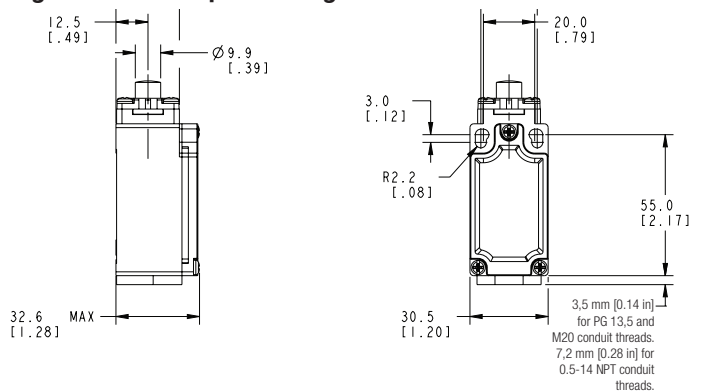

Figure 17. GLD Top Pin Plunger



Installation Instructions for MICRO SWITCH GLS Min-Din Limit Switches

ISSUE 10 **81521**

Figure 18. GLD Top Roller Plunger

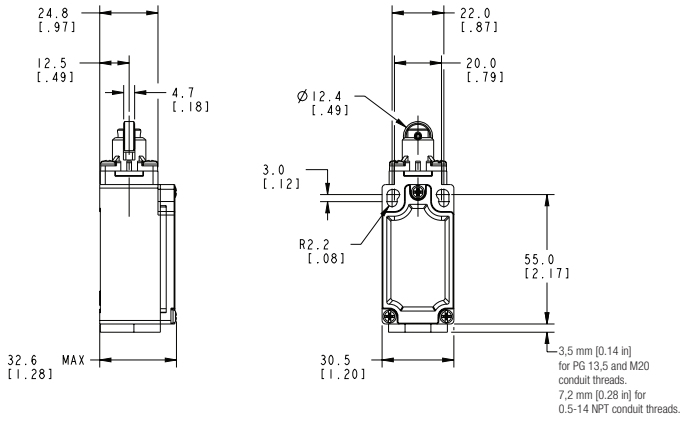

Figure 20. GLD Wobble • E7B

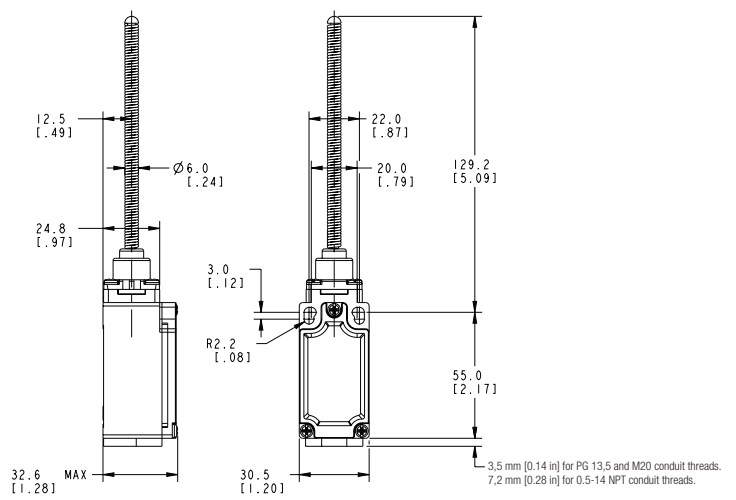

Figure 19. GLD Top Roller Arm

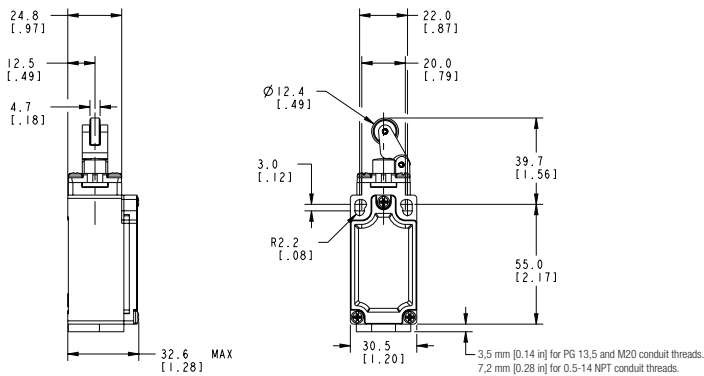

Figure 21. GLD Wobble • K8A/K8B

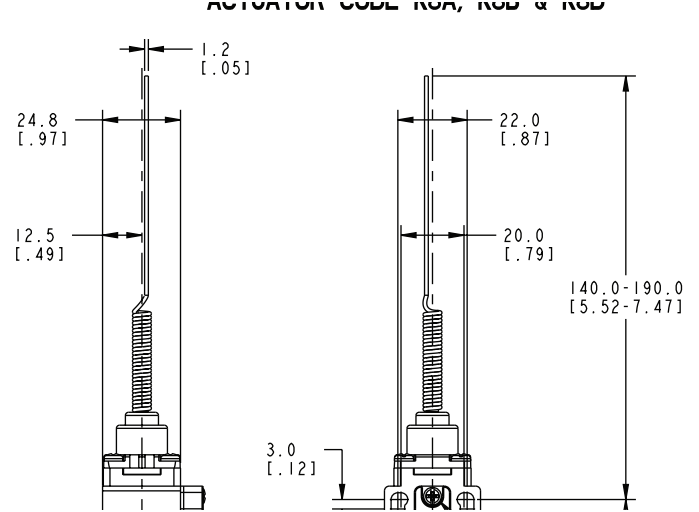
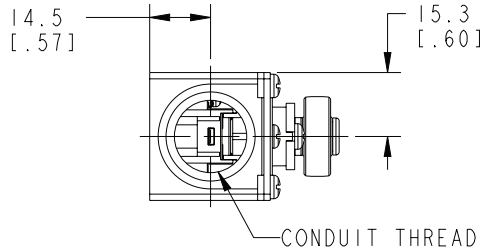

Figure 22. GLD Conduit



Installation Instructions for MICRO SWITCH GLS Min-Din Limit Switches

ISSUE 10 **81521**

Figure 23. GLE Side Rotary • A1, A1A, A1B, and A1Y

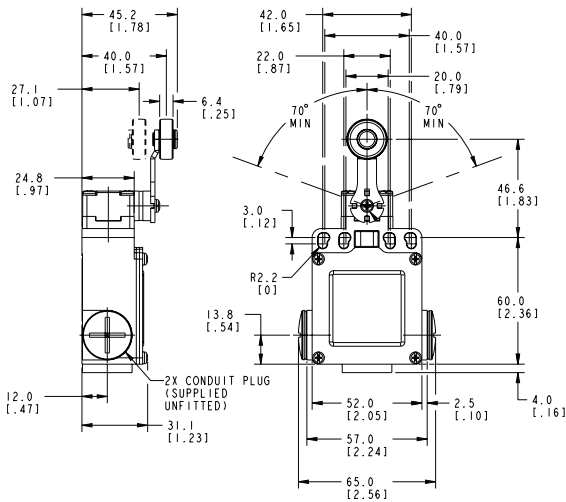

Figure 26. GLE Side Rotary • A5A and A5B

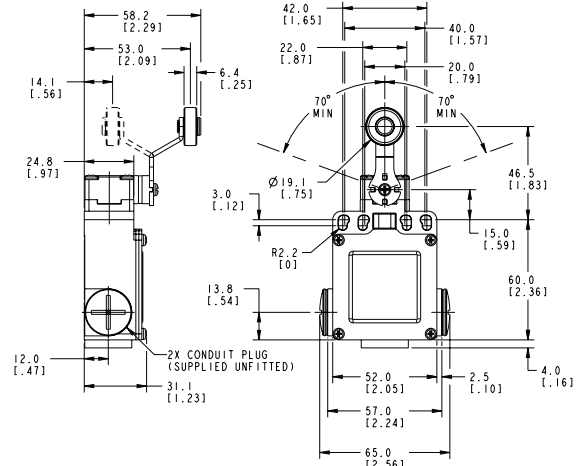

Figure 24. GLE Side Rotary • A2, A2A, A2B, and A2Y

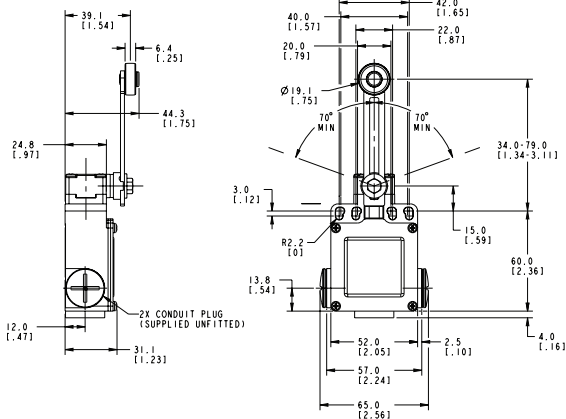

Figure 27. GLE Side Rotary • A9A

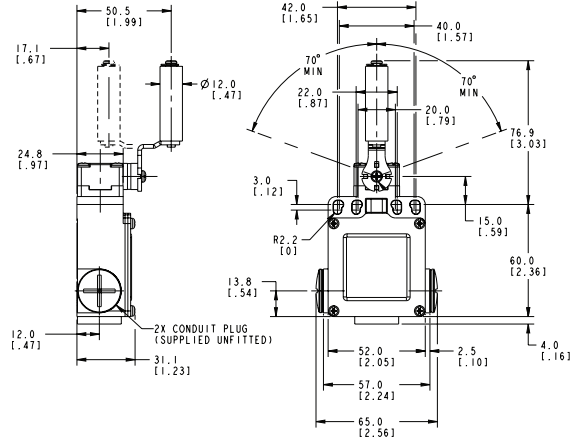

Figure 25. GLE Side Rotary • A4J and A4L

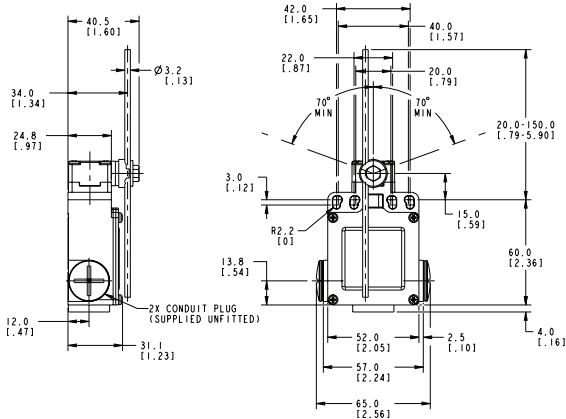
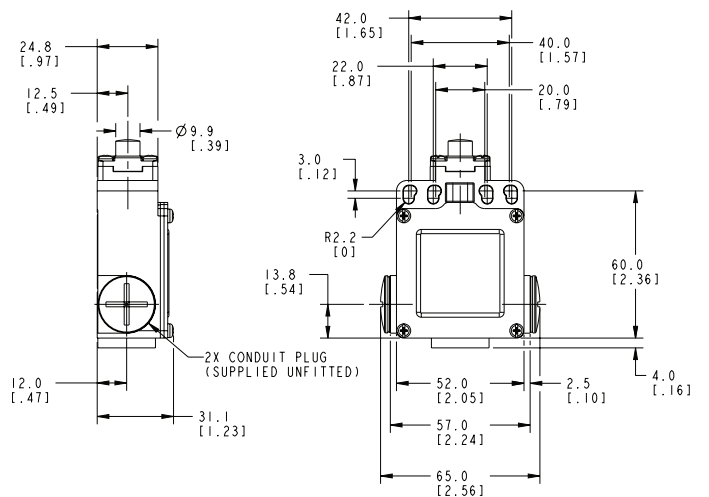

Figure 28. GLE Top Pin Plunger



Installation Instructions for MICRO SWITCH GLS Min-Din Limit Switches

ISSUE 10 **81521**

Figure 29. GLE Top Roller Plunger

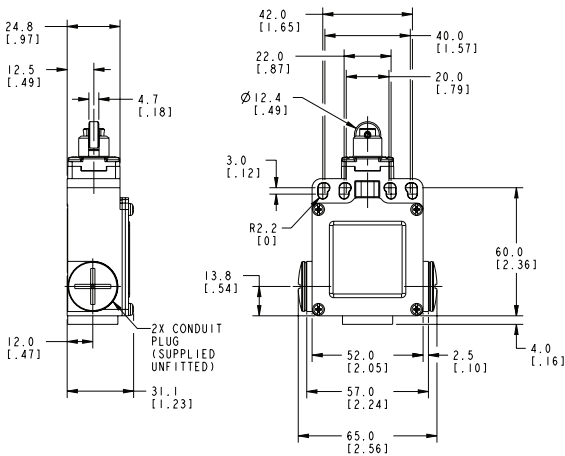

Figure 31. GLE Wobble • E7B

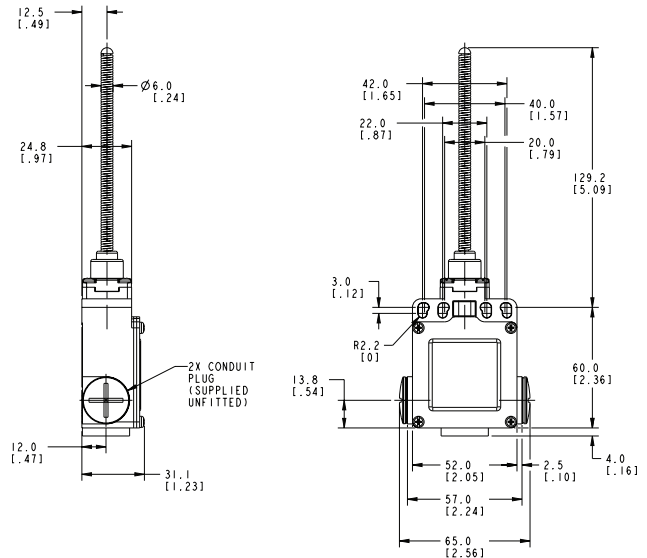

Figure 30. GLE Top Roller Arm

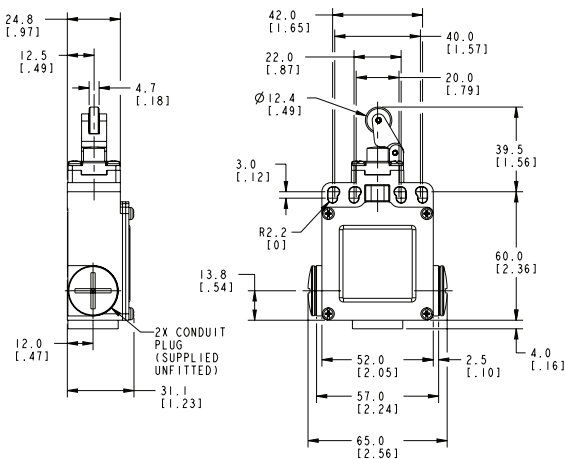

Figure 32. GLE Wobble • K8A

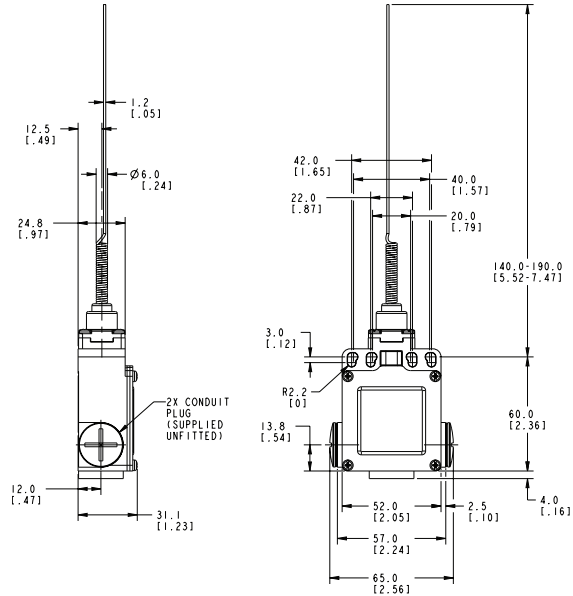
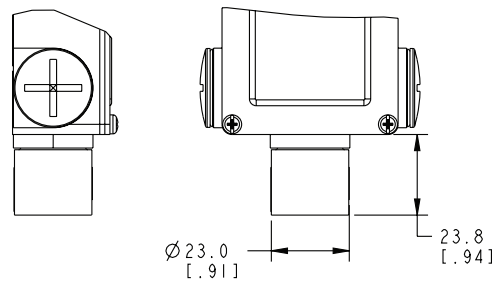

Figure 33. GLE Conduit Adapter for 0.5-14 NPT



Installation Instructions for MICRO SWITCH GLS Min-Din Limit Switches

ISSUE 10 **81521**

WARRANTY/REMEDY

Honeywell warrants goods of its manufacture as being free of defective materials and faulty workmanship. Honeywell's standard product warranty applies unless agreed to otherwise by Honeywell in writing; please refer to your order acknowledgement or consult your local sales office for specific warranty details. If warranted goods are returned to Honeywell during the period of coverage, Honeywell will repair or replace, at its option, without charge those items it finds defective. **The foregoing is buyer's sole remedy and is in lieu of all other warranties, expressed or implied, including those of merchantability and fitness for a particular purpose. In no event shall Honeywell be liable for consequential, special, or indirect damages.**

While Honeywell may provide application assistance personally, through our literature and the Honeywell web site, it is up to the customer to determine the suitability of the product in the application.

Specifications may change without notice. The information we supply is believed to be accurate and reliable as of this printing. However, we assume no responsibility for its use.

GARANZIA/RISARCIMENTO

Honeywell garantisce che i propri prodotti sono esenti da difetti nei materiali e nella manodopera. Rimane valida la garanzia di prodotto standard Honeywell, se non diversamente concordato dalla stessa per iscritto. Fare riferimento alla ricevuta dell'ordine o rivolgersi all'ufficio vendite della propria zona, per ulteriori dettagli sulla garanzia. Durante il periodo di validità della garanzia, Honeywell provvederà alla riparazione o alla sostituzione, a sua discrezione e senza alcun addebito degli articoli restituiti e riscontrati difettosi. **Tale azione costituisce l'unico risarcimento per l'acquirente e sostituisce tutte le altre garanzie, esplicite o implicite, incluse quelle della commerciabilità e dell'idoneità ad uno scopo particolare. In nessun caso Honeywell è da ritenersi responsabile per danni conseguenti, speciali o indiretti.**

Honeywell fornisce assistenza in merito alle applicazioni tramite il proprio personale, il proprio materiale informativo ed il proprio sito Web; tuttavia è responsabilità del cliente verificare l'idoneità del prodotto all'applicazione.

I dati tecnici sono soggetti a modifica senza alcun preavviso. Le informazioni fornite nel presente documento sono da ritenere accurate ed affidabili. Tuttavia, Honeywell non si assume alcuna responsabilità in merito al loro impiego.

GARANTIE UND HAFTUNGSANSPRÜCHE

Honeywell garantiert für seine hergestellten Produkte fehlerfreies Material und Qualitätsarbeit. Es gilt die durch Honeywell schriftlich mitgeteilte Standard-Produktgarantie von Honeywell. Informationen zu Garantiedetails finden Sie auf Ihrer Auftragsbestätigung bzw. erhalten Sie von Ihrer örtlichen Niederlassung. Wenn Produkte mit Garantie innerhalb der Garantiefrist an Honeywell zurückgesendet werden, ersetzt oder repariert Honeywell die als fehlerhaft angesehen Teile nach eigenem Ermessen kostenlos. **Das Vorangegangene gilt als einzige Entschädigung des Käufers und ersetzt alle anderen ausdrücklichen oder stillschweigenden Garantien, einschließlich Qualitäts- und Sachmängelhaftung. In keinem Fall haftet Honeywell für mittelbare, indirekte oder Sonderschäden.**

Obwohl Honeywell persönliche und schriftliche Anwendungshilfe sowie Informationen über die Honeywell Website bietet, ist es die Entscheidung des Kunden, ob das Produkt sich für die entsprechende Anwendung eignet.

Änderungen der technischen Daten ohne Vorankündigung sind vorbehalten. Die hier gegebenen Informationen sind nach unserem Wissen zum Zeitpunkt der Drucklegung korrekt. Wir übernehmen dennoch keinerlei Verantwortung für deren Verwendung.

GARANTIE/RECOURS

Honeywell garantit que les articles de sa fabrication sont exempts de défauts de pièces et main d'œuvre. La garantie standard sur les produits Honeywell est d'application sauf indication contraire écrite et approuvée par Honeywell. Veuillez vous reporter au récépissé de votre commande ou consulter votre bureau de vente local pour obtenir des détails spécifiques sur la garantie. Si les articles garantis sont retournés à Honeywell pendant la période de couverture, Honeywell réparera ou remplacera, à sa discrétion, gratuitement ceux qui auront été trouvés défectueux. **Ce qui précède constitue le seul recours de l'acheteur et se substitue à toutes autres garanties, explicites ou implicites, y compris celles relatives à la commercialisation ou la compatibilité avec une application particulière. Honeywell ne peut être en aucun cas tenu responsable de tout dommage indirect, spécial ou accessoire.**

Bien que nous fournissions une assistance aux applications par le biais de notre bibliographie et le site Web Honeywell, il appartient au client de déterminer l'aptitude du produit pour son application.

Les caractéristiques techniques peuvent changer sans préavis. Les informations que nous diffusons sont réputées précises et fiables au moment de leur impression. Nous n'assumons cependant aucune responsabilité pour leur usage.

CLAUSULA DE GARANTÍA

Honeywell garantiza que todos los productos que fabrica están libres de defectos de mano de obra o materiales. La garantía del producto estándar de Honeywell se aplica a menos que Honeywell haya acordado lo contrario por escrito; consulte a su confirmación de orden o a su oficina de ventas local para detalles específicos de garantía. Si se devuelven productos con garantía a Honeywell durante el periodo de cobertura, Honeywell los reparará o reemplazará, de manera opcional, si determina que están defectuosos. **Esta cláusula de garantía sustituye a cualquier otra garantía, ya sea explícita o implícita. En ningún caso Honeywell será responsable por daños consecuentes, especiales o indirectos.**

Aunque Honeywell ofrece asistencia personal para las aplicaciones por medio de sus publicaciones y páginas web, es el cliente quien debe determinar la idoneidad del producto en la aplicación.

Las especificaciones pueden cambiar sin previo aviso. La información suministrada es considerada correcta y fiable en el momento de esta impresión. No obstante, no asumimos la responsabilidad por su uso.

GARANTIA/SOLUÇÕES

A Honeywell garante seus produtos contra defeitos de material e de fabricação. A garantia padrão de produto da Honeywell se aplica a menos que haja um acordo diferente por escrito com a Honeywell; consulte a sua confirmação de encomenda ou consulte o escritório de vendas local para obter detalhes específicos da garantia. Quando produtos dentro do período de cobertura da garantia forem devolvidos à Honeywell, esta se compromete a reparar ou substituir, de acordo com a opção da empresa, por um novo aqueles produtos que consideramos defeituosos. **O acima estipulado é a única solução oferecida ao comprador e substitui quaisquer outras garantias, expressas ou implícitas, inclusive garantias de comerciabilidade e adequação a um fim específico. Em hipótese alguma a Honeywell deve ser responsabilizada por danos consequenciais, especiais ou indiretos.**

Embora a Honeywell proporcione assistência pessoal, através de literatura e de seu site na web, cabe ao cliente determinar qual produto é mais adequado à sua aplicação.

Installation Instructions for MICRO SWITCH GLS Min-Din Limit Switches

ISSUE 10 **81521**

Especificações podem ser alteradas sem aviso prévio. Acreditamos que as informações aqui contidas eram as mais precisas e confiáveis no momento da impressão desta publicação. No entanto, não assumimos qualquer responsabilidade pelo uso destas.

保证/补救

霍尼韦尔保证，本公司所制造的产品不存在任何有缺陷的材料和工艺上的缺陷。如霍尼韦尔未另外以书面形式同意，则适用霍尼韦尔的标准产品保证；请参阅订单确认书或咨询当地销售处了解具体保修细节。如果用户在保修期内将产品退回公司，霍尼韦尔将负责免费维修或更换存在缺陷的零部件。上述条款是购买人所能获得的唯一补救方法，并取代所有其他明示或暗指的保证，包括有关针对某一特定目的的适销性和适用性的保证。霍尼韦尔对衍生性损害、特殊损害与间接损害概不负责。

尽管我们可以派专人、通过我们的技术资料 and 霍尼韦尔网站等方式提供应用支持，但确定产品在实际应用中是否适合则取决于用户自身。

技术规格若有改动，恕不另行通知。本文所提供的信息自印刷之日起均视为准确、可靠。但是，我们不对本文的使用承担任何责任。

For more information

Honeywell Sensing and Internet of Things services its customers through a worldwide network of sales offices and distributors. For application assistance, current specifications, pricing or the nearest Authorized Distributor, visit sensing.honeywell.com or call:

Asia Pacific	+65 6355-2828
Europe	+44 1698 481481
USA/Canada	+1-800-537-6945

Honeywell Sensing and Internet of Things

9680 Old Bailes Road
Fort Mill, SC 29707
www.honeywell.com

PK 81521-10-MLa | 10 | 04/19
© 2019 Honeywell International Inc. All rights reserved.

Honeywell