

## Technical Note

# Output Signal Adjustment and Temperature Compensation for Honeywell Basic Force Sensors, TBF Series, Compensated/Unamplified

### 1.0 INTRODUCTION

Honeywell offers a broad range of board mount force sensors including fully amplified and compensated or uncompensated sensors.

- **Amplified and compensated:** These sensors are usually used as is (plug and play) without the need for additional modification by the customer. Examples are Honeywell's FSA Series.
- **Compensated:** These sensors provide part-to-part interchangeability, calibration, and temperature compensation. Examples are Honeywell's 1865 Series and TBF Series. Compensated sensors, however, may require the use of amplification circuitry, assuming that an ASIC (Application-Specific Integrated Circuit) with a mV input ADC (Analog to Digital Converter) is not being used. Examples of useful amplification circuitry that can be used with the 1865 Series and TBF Series are shown in Section 2.0.
- **Uncompensated:** These sensors provide raw sensor output and are not compensated in any way. Examples are Honeywell's FSS Series, FSS-SMT Series and FSG Series. They usually require some form of compensation to be able to be used in many applications.

This Technical Note describes several compensation techniques for use with the TBF Series (Figure 1). Pinouts shown are for the Leadless SMT devices. See the published datasheets for the TBF Series pinouts.

Figure 1. Basic Force Sensors: TBF Series



### 2.0 AMPLIFICATION CIRCUIT EXAMPLES

There are numerous methods for amplifying the raw output from a Wheatstone bridge sensor. Two examples are shown in Figures 2 and 3.

#### Amplification Using a Discrete Op-Amp (Figure 2.)

This method uses a discrete op-amp such as the LM2902 or LT1014. This allows the user to change the null offset as well as the gain. The null offset should be adjusted using one of the procedures in Section 2.0 prior to using this circuit.

The equation for this circuit is:

$$((2 R_2/R_1) + 1) \times (R_4/R_3) + V_{offset}$$

$$V_{offset} = V_s \times (R_6/R_5 + R_6)$$

Where:

$R_1$  = 20 kOhm potentiometer

$R_2$  = 100 kOhm

$R_3$  = 100 kOhm

$R_4$  = 200 kOhm

$R_5$  = 100 kOhm

$R_6$  = 50 kOhm potentiometer

The supply voltage to the op-amp needs to be 8 Vdc minimum because the maximum output from the LM2902 is  $V_s - 1.5$  Vdc. The supply to the voltage divider and the TBF Series sensor can be another regulated voltage, i.e., 3.3 Vdc or 5 Vdc. If this is done, then the grounds to the supplies need to be connected (commoned) together.

Figure 2. Amplification Circuit using a Discrete Op-Amp

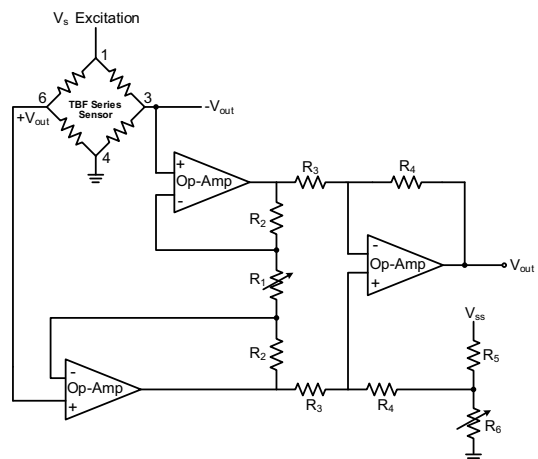

# Technical Note

## Output Signal Adjustment and Temperature Compensation for Honeywell Basic Force Sensors, TBF Series, Compensated/Unamplified

### Amplification Using an Instrumentation Amplifier (Figure 3.)

There are manufacturers who provide complete instrumentation amplifiers, such as the AD623, that only require a few resistors to set the offset and span.

The gain is adjusted by selecting the value of  $R_g$ :

$$R_g = 100000/(\text{gain}-1).$$

As an example, for a gain of 40, the value of  $R_g$  would be 2564 Ohm. The offset adjustment is made by changing the reference voltage, which can be accomplished using two resistors as a voltage divider.

Figure 3. Amplification Circuit Using an Instrumentation Amplifier

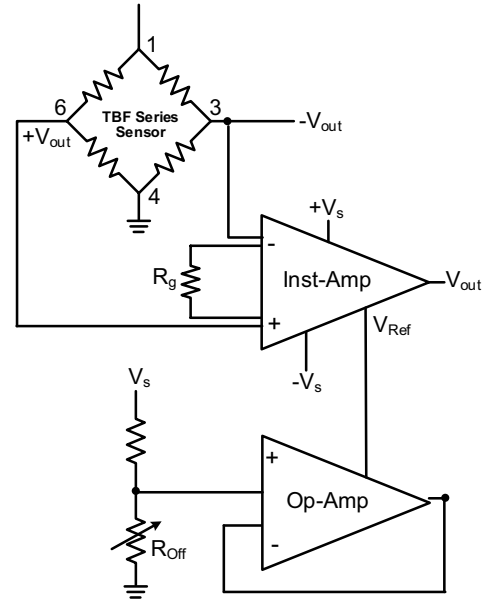

### Find out more

To learn more about Honeywell's sensing and control products, call **1-800-537-6945**, visit **sensing.honeywell.com**, or e-mail inquiries to **info.sc@honeywell.com**

Sensing and Productivity Solutions  
Honeywell  
1985 Douglas Drive North  
Golden Valley, MN 55422  
**honeywell.com**

**Warranty.** Honeywell warrants goods of its manufacture as being free of defective materials and faulty workmanship. Honeywell's standard product warranty applies unless agreed to otherwise by Honeywell in writing; please refer to your order acknowledgement or consult your local sales office for specific warranty details. If warranted goods are returned to Honeywell during the period of coverage, Honeywell will repair or replace, at its option, without charge those items it finds defective. **The foregoing is buyer's sole remedy and is in lieu of all warranties, expressed or implied, including those of merchantability and fitness for a particular purpose. In no event shall Honeywell be liable for consequential, special, or indirect damages.**

While we provide application assistance personally, through our literature and the Honeywell web site, it is up to the customer to determine the suitability of the product in the application.

Specifications may change without notice. The information we supply is believed to be accurate and reliable as of this printing. However, we assume no responsibility for its use.

**Honeywell**