

Aerospace Linear Variable Differential Transformers

Single Channel, Dual Parallel, & Dual Tandem Series

000820
Issue 1

Datasheet

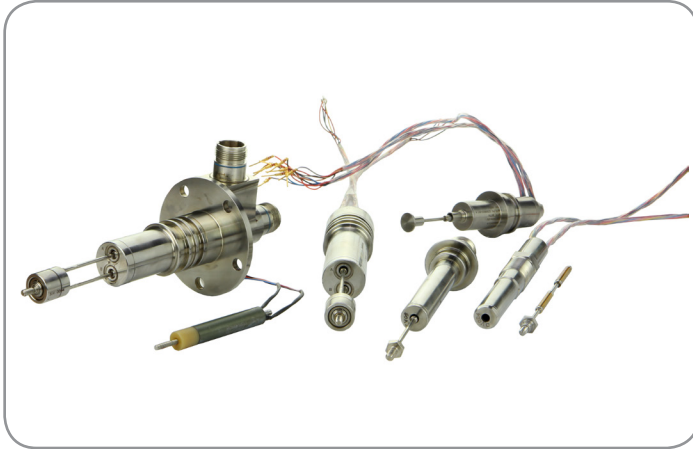

DESCRIPTION

Aerospace Design Engineers working on flight controls, engines, nose wheel steering and pilot control applications have a need for continuous position monitoring. Honeywell's Linear Variable Differential Transformers (LVDT) provide solutions for each of these applications, and more.

Honeywell's new aerospace LVDT provides infinite resolution linear position solutions designed for use in harsh environments. They are an ideal product to be used on next generation aircraft which require expedited design cycle time from an experienced, stable supplier with an extensive aerospace product install base.

VALUE TO CUSTOMERS

- Pre-validated configurable LVDT platform approach to reduce design cycle time and get to market faster
- Honeywell has an established legacy of providing high quality products within the aerospace industry
- Reduced installation time by engineering design: rig point position eliminates shimming

FEATURES

- Pre-validated platform approach: Single channel, dual channel, and dual tandem offerings ensure a wide-variety of configurations and applications can be accommodated
- Rig point position eliminates need to shim during installation
- Enhanced reliability: Improved mean time between failure (MTBF) through industry-leading winding techniques, high-strength materials, and industry-leading design
- Supplier stability: Minimizes cost to serve and ensures supply
- Global engineering and application expertise: customers with a global footprint can rest assured that there is local support for new applications and troubleshooting

POTENTIAL APPLICATIONS

- Aerospace and defense
 - Flight controls (PFC/SFC)
 - Engines (mechanisms/valves)
 - Nose-wheel steering
 - Pilot controls

DIFFERENTIATION

- Pre-validated configurable platform approach to reduce cycle time and get to market faster
- Honeywell has a strong legacy of providing high-quality products within the aerospace industry
- Decreased failure rate through industry-leading design

PORTFOLIO

Honeywell's aerospace LVDTs are part of a comprehensive line of aerospace sensors, switches, and value-added solutions. To view Honeywell's complete product offering, click [here](#).

Aerospace LVDT, Single Channel, Dual Parallel, & Dual Tandem Series

Table 1. Specifications

Characteristic	Parameter
Product type	Aerospace LVDT: linear ac-ac
Range	8,89 mm to 35,56 mm [0.35 in to 1.4 in] stroke
Housing material	17-4 PH stainless steel
Electrical connectors	EN2997YE01005MN, M83723/88P1005N, D38999/27YB5XN
Accuracy	±0.5% of the full stroke gain from 0 % to 100 % of the LVDT stroke @ 21 °C [70 °F]
MTBF	1 million hours min.
Current consumption	11 mA max.
Input impedance	650 ohms min. @ 3000 Hz
Output impedance	2000 ohms max. @ 3000 Hz
Mechanical stroke	0,254 mm [0.010 in] (additional to electrical stroke)
Normal operating pressure	2000 psi
Proof pressure	3000 psi
Burst pressure	4000 psi
Pressure cycles	50,000 cycles from 0 psig to 2000 psig @ 200 °C [392 °F]
Altitude sea level	to 55000 ft
Life requirements	1,000,000 hours min.
Normal operating temp. range	-55 °C to 200 °C [-67 °F to 392 °F]
Full scale gain	±0.5 V/V @ extreme strokes
Phase shift between primary to secondary	15° max. @ room temperature
Phase shift between secondary to secondary	5° max. @ room temperature
Temperature coefficient	0.25 % for every 100 °F change in temperature in addition to 0.5 % room temperature accuracy
Sum voltage	(V1+V2) shall be 4.45 VRMS min. to 5.54 VRMS max.
Room temperature	21° C ±5° C [70° F ±10°F]
Insulation resistance	100 megohms min. at 500 Vdc
Mechanical endurance	100,000 mechanical cycles (fully extended-fully retracted-fully extended) min.
Vibration	60 G @ 5 Hz to 2000 Hz
Dielectric strength	1500 V RMS min. at 60 Hz
Excitation	7.07 ±0.14 V RMS sinusoidal wave at 3000 Hz ±50 Hz
Electrical grounding and bonding	5 milliohms max.
Crosstalk	less than 0.0010 V/V
Channel tracking	less than 0.36 % of full scale at all stroke positions and across normal operating temperature
Weight	0.22 lb to 2.1 lb

Aerospace LVDT, Single Channel, Dual Parallel, & Dual Tandem Series

Table 2. Government and Military Standards

Description	Standard
Reliability prediction of electronic equipment	MIL-HDBK-217F Notice 2
Environmental Test Methods	MIL-STD 810G
Jet A-1 w/Additives and Jet A-1 w/o Additives	ASTM D 1655
Requirements for Soldered Electrical and Electronic Assemblies	IPC J-STD-001B
Requirements for Electronic Grade Solder Alloys and Fluxed and Non-Fluxed Solid Solders for Electronic Soldering Applicants	IPC J-STD-006
Wire, electrical, fluoropolymer-insulated, cross linked modified ETFE, lightweight, silver-coated, high-strength copper alloy, 200°C, 600 volt	AS22759/33 or Equivalent
Magnet Wire	NEMA MW1000
Environmental Conditions and Test Procedures for Airborne Equipment	RTCA DO-160G
Metallic Materials Properties Development and Standardization	MMPDS
Operating Altitude	RTCA-DO-160G, Section 4, Category F3
Vibration	RTCA-DO-160G, Section 8, Category R, Curve W with an amplification Q factor of 3
Shock and Crash Safety	RTCA-DO-160G, Section 7.2.1 (operational shock) RTCA-DO-160G, Section 7.3.1 (crash safety impulse) RTCA-DO-160G, Section 7.3.3 (crash safety sustained)
Fungus	RTCA-DO-160G, Section 13, Category F
Humidity	RTCA-DO-160G, Section 6, Category B
Sand and Dust	RTCA-DO-160G, Section 12, Category D
Salt Spray	RTCA-DO-160G, Section 14, Category T
Icing	RTCA-DO-160G, Section 24, Category A
Water proofness	RTCA-DO-160G, Section 10, Category S
Temperature variation	RTCA-DO-160G, Section 5, Category A
Temperature shock	MIL-STD-810G, Method 503.5 for 100 cycles
Explosive atmosphere	RTCA-DO-160G, Section 9, Category E

Aerospace LVDT, Single Channel, Dual Parallel, & Dual Tandem Series

Figure 1. Single-Channel Product Nomenclature

Series	Channels	Stroke	Mounting	Termination	Probe Fitting	Reserved
1LVT Aerospace LVDT	S Single channel	035 8,89 mm [0.35 in]	A Threaded	A EN2997YE01005MN	A 0.138-32 threaded	
		050 12,7 mm [0.50 in]	B Flanged	B M83723/88P1005N	B 0.164-32 threaded	
		070 17,78 mm [0.70 in]		C D38999/27YB5XN		
		100 25,4 mm [1.0 in]		D Pigtail (flying leads)		
		140 35,56 mm [1.40 in]				

Figure 2. Dual-Tandem Product Nomenclature

Series	Channels	Stroke	Mounting	Termination	Probe Fitting	Reserved
1LVT Aerospace LVDT	T Dual tandem	035 8,89 mm [0.35 in]	A Threaded	D Flying leads	B 0.164-32 threaded	
		050 12,7 mm [0.50 in]	B Flanged			
		070 17,78 mm [0.70 in]				
		100 25,4 mm [1.0 in]				
		140 35,56 mm [1.40 in]				

Figure 3. Dual-Parallel Product Nomenclature

Series	Channels	Stroke	Mounting	Termination	Probe Fitting	Reserved
1LVT Aerospace LVDT	P Dual parallel	070 17,78 mm [0.70 in]	A Threaded	A EN2997YE01005MN*	A 0.138-32 threaded	
		100 25,4 mm [1.0 in]	B Flanged	B M83723/88P1005N*	B 0.164-32 threaded	
		140 35,56 mm [1.40 in]		C D38999/27YB5XN*		
				D Pigtail (flying leads)		

Aerospace LVDT, Single Channel, Dual Parallel, & Dual Tandem Series

Figure 4. Single-Channel (Wired) Dimensions

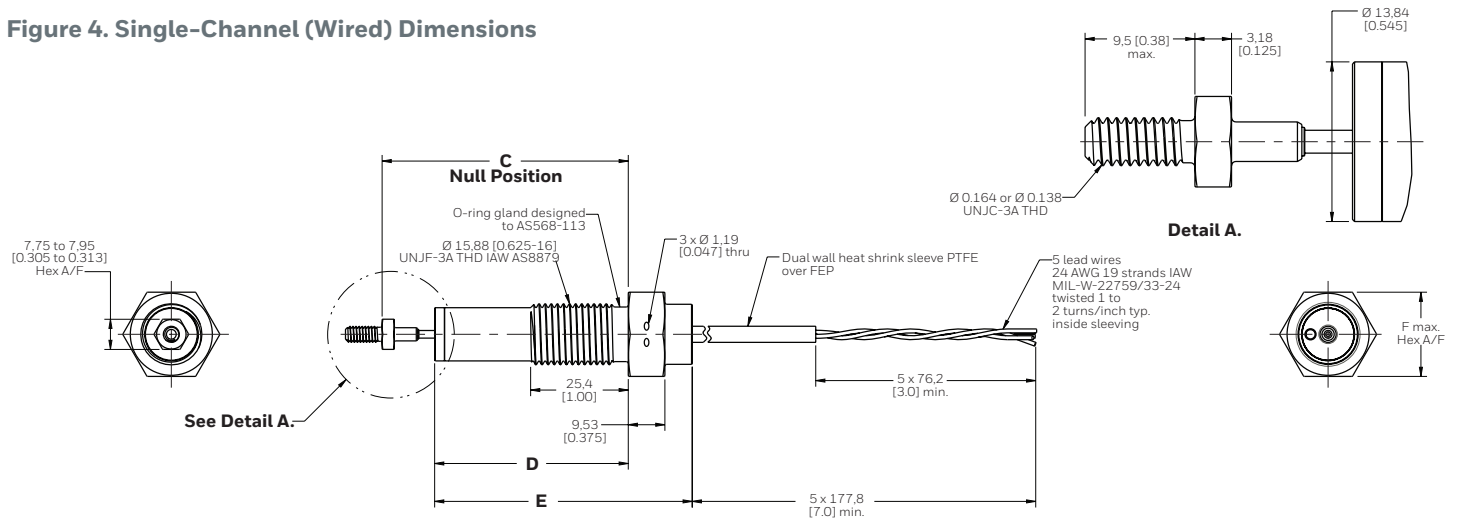

Figure 5. Single-Channel (Flanged) Dimensions

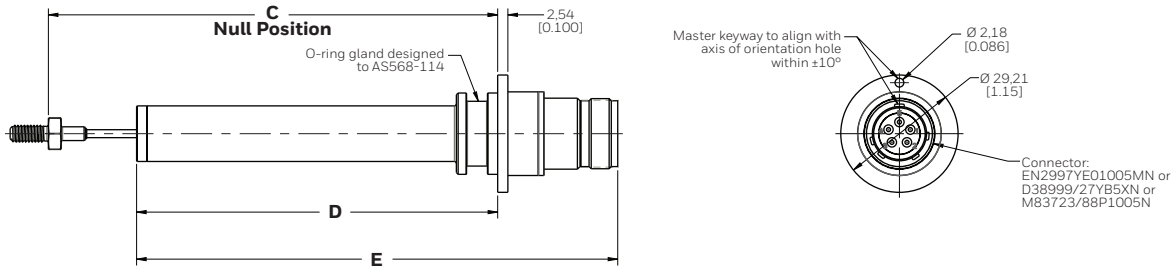

Table 3. Single Channel Dimensions

Mounting Type	Catalog Listing	Total Electrical Stroke "A"	Total Mechanical Stroke "B"	Rig Position "C"	Housing Length "D"	Housing Length "E"	Housing Length "F"	Weight
Threaded	1LVTS035ADB	8,89 mm [0.35 in]	9,4 mm [0.37 in]	64 mm [2.52 in]	50,3 mm [1.98 in]	67,06 mm [2.64 in]	22,23 mm [0.875 in]	0.22 lb max.
Threaded	1LVTS050ADB	12,7 mm [0.50 in]	13,2 mm [0.52 in]	66,04 mm [2.60 in]	50,3 mm [1.98 in]	67,06 mm [2.64 in]	22,23 mm [0.875 in]	0.22 lb max.
Flanged	1LVTS100BAB	25,4 mm [1.0 in]	25,91 mm [1.02 in]	111,76 mm [4.40 in]	89,9 mm [3.54 in]	119,89 mm [4.72 in]	-	0.30 lb max.

Figure 6. Single-Channel Wiring

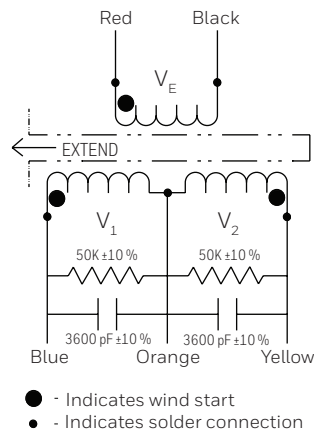

Figure 7. Single-Channel Stroke Definition

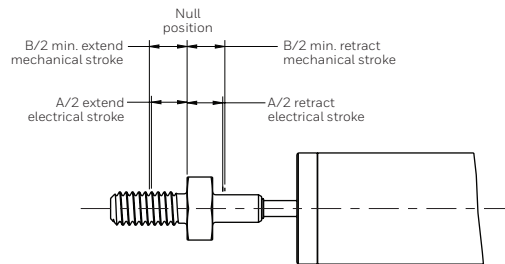
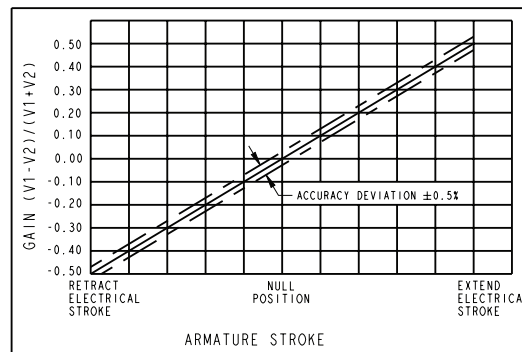

Figure 8. Single-Channel Gain vs. Stroke



Aerospace LVDT, Single Channel, Dual Parallel, & Dual Tandem Series

Figure 9. Dual-Tandem Dimensions mm [in]

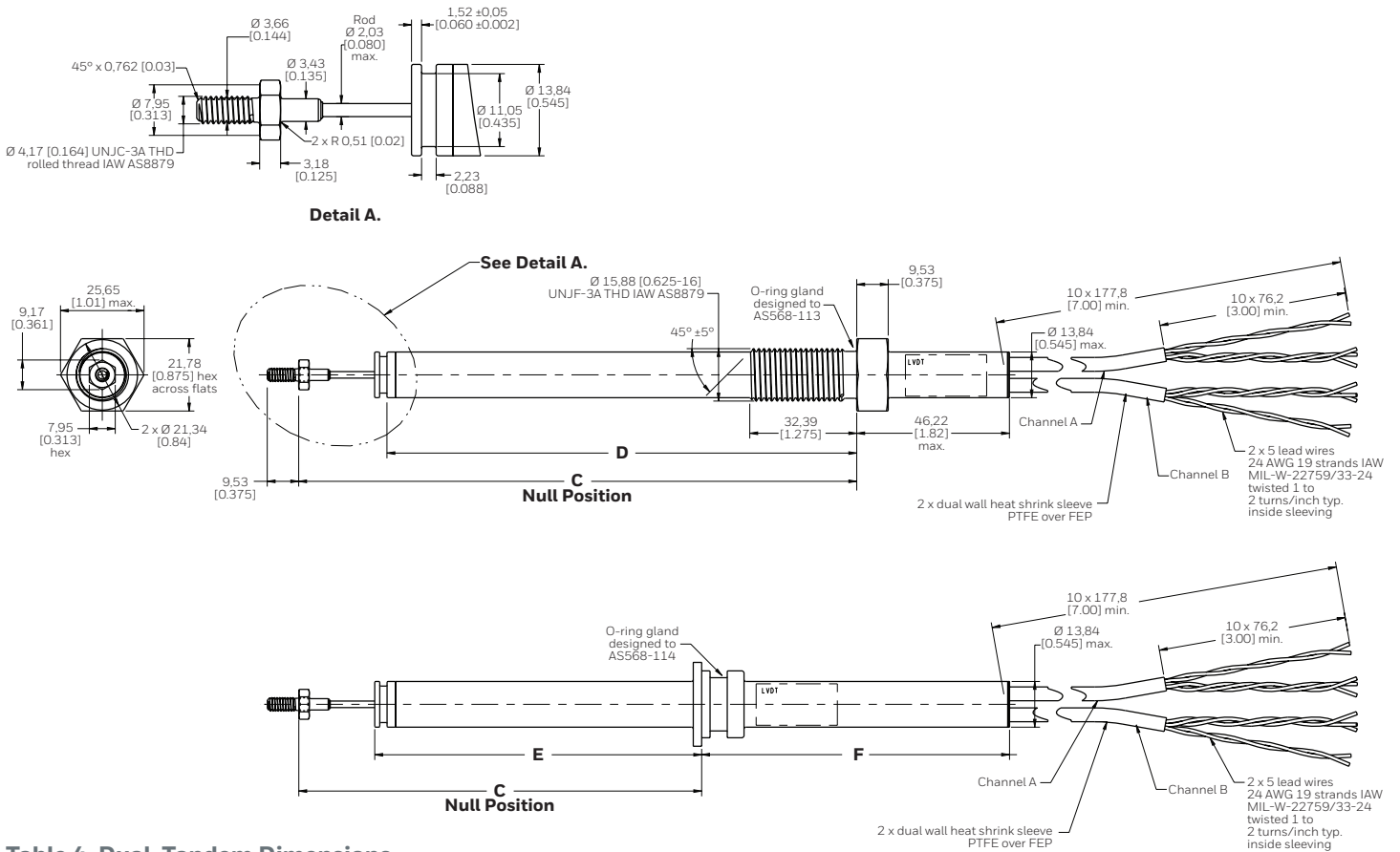

Table 4. Dual-Tandem Dimensions

Mounting Type	Catalog Listing	Total Electrical Stroke "A"	Total Mechanical Stroke "B"	Rig Position "C"	Front Housing Length for Threaded Config "D"	Front Housing Length for Flanged Config "E"	Rear Housing Length for Flanged Config "F"
Threaded	1LVTT140ADB	35,56 mm [1.40 in]	36,07 mm [1.42 in]	168,96 mm [6.652 in]	142,24 mm [5.60 in]	-	-
Flanged	1LVTT140BDB	35,56 mm [1.40 in]	36,07 mm [1.42 in]	121,97 mm [4.802 in]	-	95,25 mm [3.75 in]	93,22 mm [3.67 in] max.
Threaded	1LVTT070ADB	17,78 mm [0.7 in]	18,29 mm [0.72 in]	138,73 mm [5.462 in]	122,43 mm [4.82 in]	-	-

Figure 10. Dual-Tandem Wiring

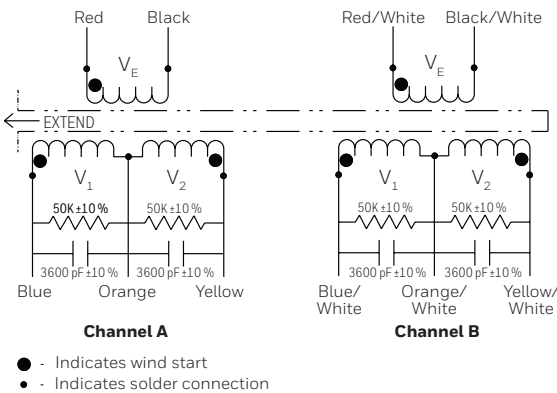

Figure 11. Dual-Tandem Stroke Definition

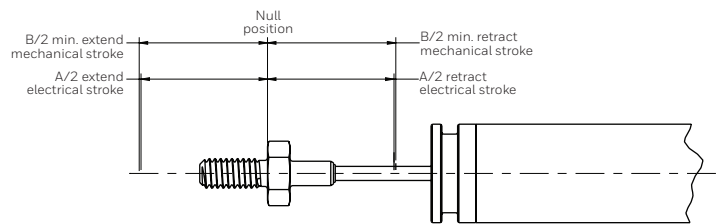
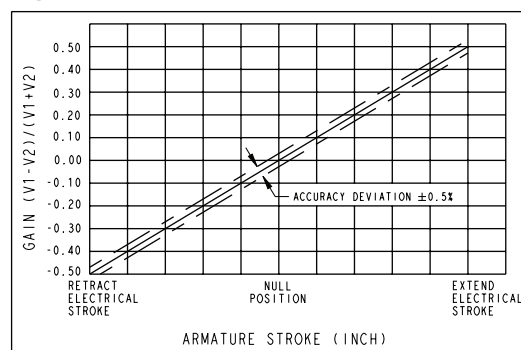

Figure 12. Dual-Tandem Gain vs. Stroke



Aerospace LVDT, Single Channel, Dual Parallel, & Dual Tandem Series

Figure 13. Dual-Parallel (Wired) Dimensions

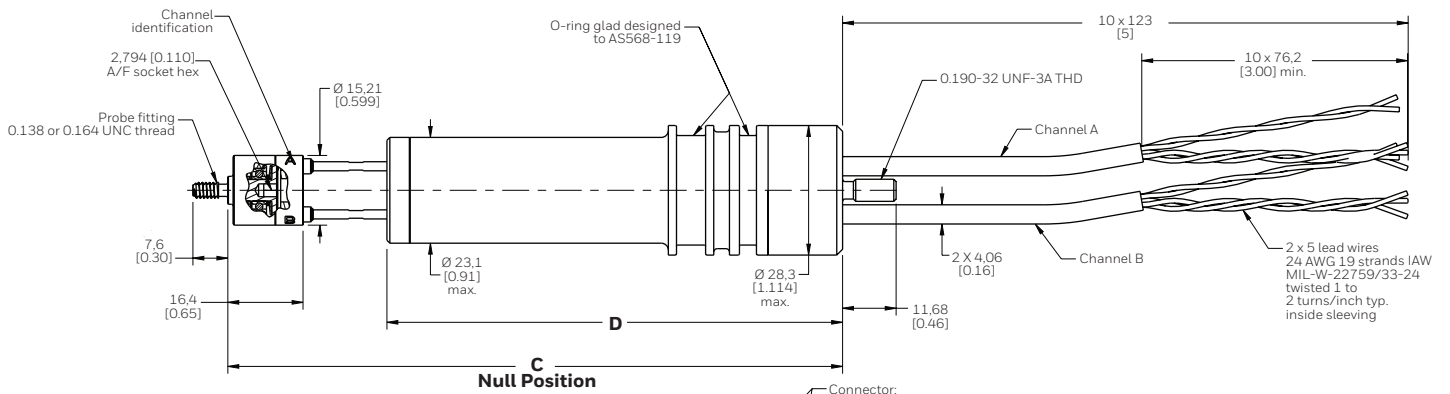

Figure 14. Dual-Parallel (Flanged) Dimensions

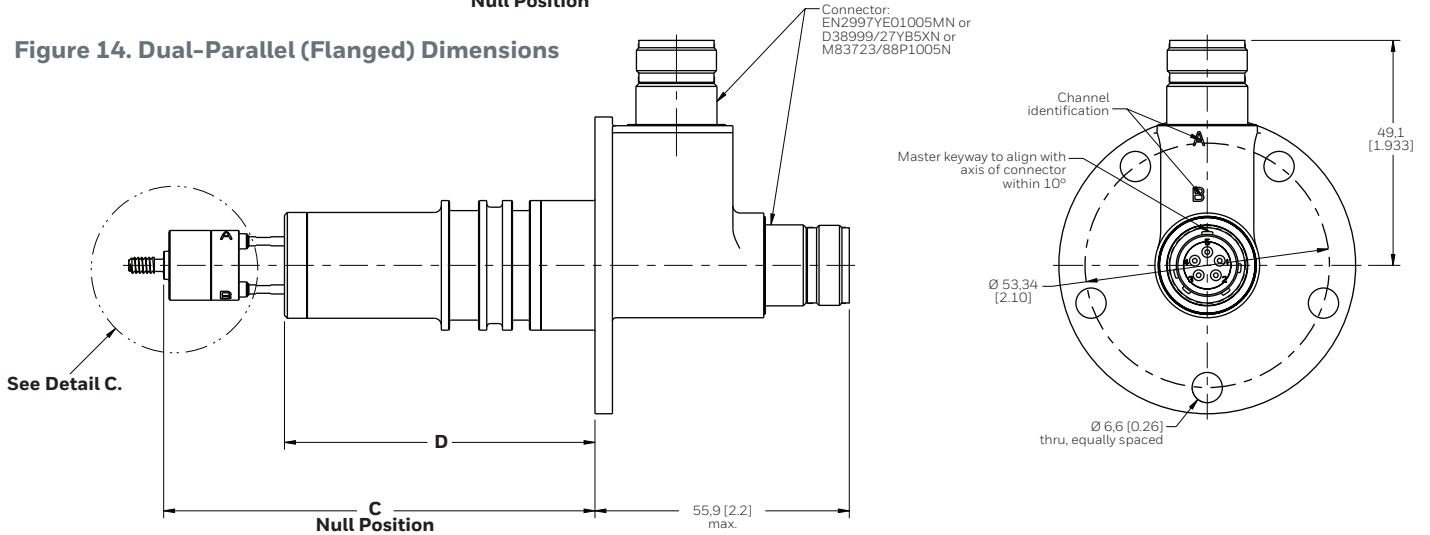
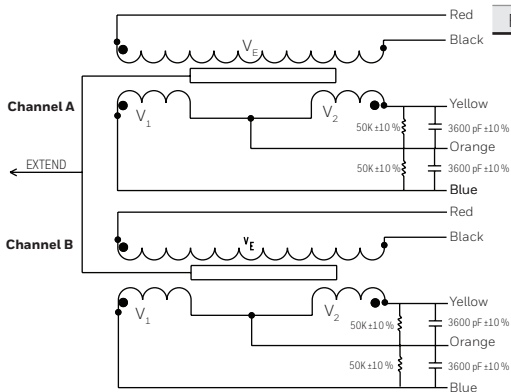

Figure 15. Dual-Parallel Wiring



- Indicates wind start
- Indicates solder connection

Wire Color

Pin Number	Channel A	Channel B
1	Red	Red
2	Black	Black
3	Blue	Blue
4	Orange	Orange
5	Yellow	Yellow

Table 5. Dual-Parallel Dimensions

Mounting Type	Catalog Listing	Total Electrical Stroke "B"	Total Mechanical Stroke "C"	Rig Position "C"	Housing Length	Weight
Threaded	1LVTP140ADA	35,56 mm [1.40 in]	4,06 mm [0.16 in]	135,1 mm [5.335 in]	100,33 mm [3.95 in]	0.55 lb max.
Flanged	1LVTP070BAA	17,78 mm [0.7 in]	18,29 mm [0.72 in]	94,16 mm [3.707 in]	68,58 mm [2.70 in]	1.00 lb max.

Figure 16. Dual-Parallel Stroke Definition

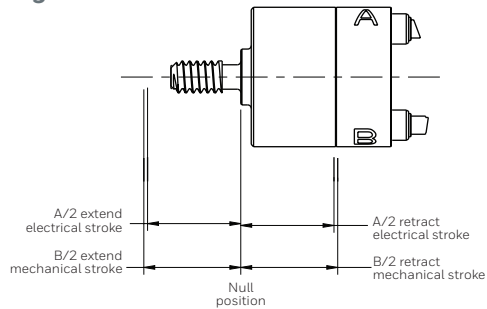
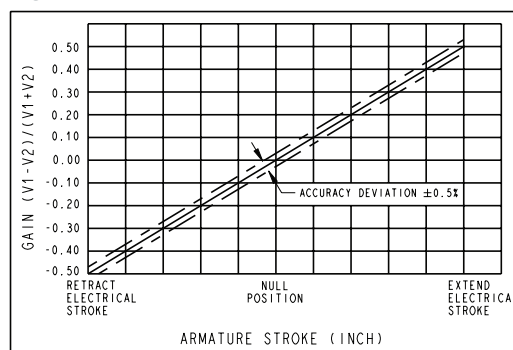

Figure 17. Dual-Parallel Gain vs. Stroke



ADDITIONAL MATERIALS

The following associated literature is available at sensing.honeywell.com:

- Product range guide
- Installation instructions
- Application Note
- Technical note

Find out more

Honeywell serves its customers through a worldwide network of sales offices, representatives and distributors. For application assistance, current specifications, pricing or name of the nearest Authorized Distributor, contact your local sales office.

To learn more about Honeywell's sensing and switching products,

call **+1-815-235-6847** or **1-800-537-6945**,

visit **sensing.honeywell.com**,
or e-mail inquiries to **info.sc@honeywell.com**

Honeywell Sensing and Internet of Things

9680 Old Bailes Road
Fort Mill, SC 29707
honeywell.com

WARNING **PERSONAL INJURY**

DO NOT USE these products as safety or emergency stop devices or in any other application where failure of the product could result in personal injury.

Failure to comply with these instructions could result in death or serious injury.

WARNING **MISUSE OF DOCUMENTATION**

- The information presented in this product sheet is for reference only. Do not use this document as a product installation guide.
- Complete installation, operation, and maintenance information is provided in the instructions supplied with each product.

Failure to comply with these instructions could result in death or serious injury.

Warranty/Remedy

Honeywell warrants goods of its manufacture as being free of defective materials and faulty workmanship during the applicable warranty period. Honeywell's standard product warranty applies unless agreed to otherwise by Honeywell in writing; please refer to your order acknowledgment or consult your local sales office for specific warranty details. If warranted goods are returned to Honeywell during the period of coverage, Honeywell will repair or replace, at its option, without charge those items that Honeywell, in its sole discretion, finds defective. **The foregoing is buyer's sole remedy and is in lieu of all other warranties, expressed or implied, including those of merchantability and fitness for a particular purpose. In no event shall Honeywell be liable for consequential, special, or indirect damages.**

While Honeywell may provide application assistance personally, through our literature and the Honeywell web site, it is buyer's sole responsibility to determine the suitability of the product in the application.

Specifications may change without notice. The information we supply is believed to be accurate and reliable as of this writing. However, Honeywell assumes no responsibility for its use.

Honeywell