

DO NOT SCALE DRAWING	B-2102-D	REV.
	 THIRD ANGLE PROJECTION	

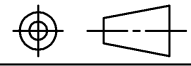
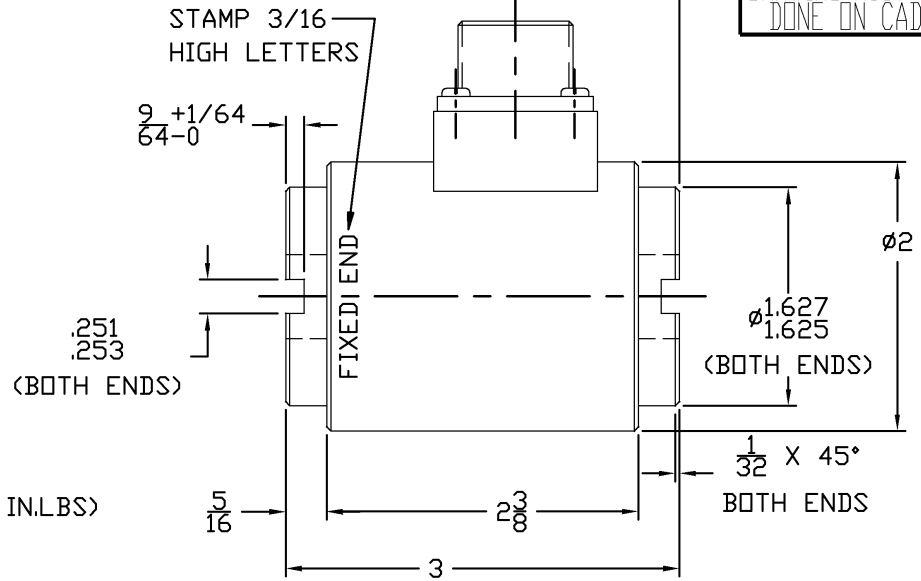
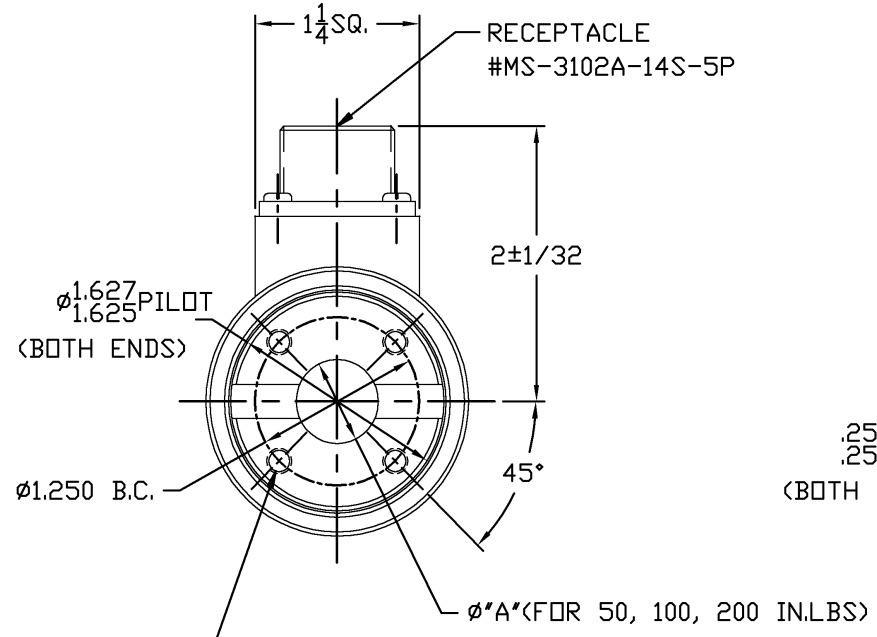

#10-24-3B UNC - TAP 3/8 DEEP
(4) HOLES EQUALLY SPACED
AS SHOWN - BOTH ENDS

Ⓝ PERFORMANCE SPEC. S-2102

2102-1000	1000	
2102-500	500	
2102-200	200	5/8 THRU
2102-100	100	5/8 THRU
2102-50	50	5/8 THRU
MODEL NO.	CAP. (IN LBS)	φ*A*

NOTICE TO PERSONS RECEIVING THIS DRAWING AND/OR TECHNICAL INFORMATION
Lebow Products claims proprietary rights to the material disclosed hereon. This drawing and/or technical information is issued in confidence for engineering information only and may not be reproduced or used to manufacture anything shown or referred to hereon without direct written permission from Lebow Products to the user. This drawing and/or technical information is the property of Lebow Products and is loaned for mutual assistance, to be returned when its purpose has been served.

DET. NO.	PART NO.	DESCRIPTION	REQ'D.
		Lebow Products Lebow Products Troy, Michigan	
UNLESS OTHERWISE SPECIFIED LINEAR DIMENSIONS ARE IN INCHES REMOVE ALL BURRS & ANGULAR DIMENSIONS ARE IN DEGREES SHARP EDGES DIMENSION LIMITS HELD AFTER PLATING SURFACE FINISH 125 ✓			
TOLERANCES		DR. BY:	CHK'D. BY:
DRILLED HOLES -000 +007	TWO PLACE DECIMALS ± .00	DATE:	ENGR.
THREE PLACE DECIMALS ± .005	ANGLES ± 0 '30'	9/1/61	
SCALE: NONE	REF. DWG. B-10987	FRACTIONAL DIMENSIONS ± 1/64	MAT'L. -
TITLE:		MODEL: 2102	
D.O. REACTION TORQUE SENSOR		DRAWING NO.	REV.
		B-2102-D	

REVISIONS	DESCRIPTION	DATE
ADD. PERFORM. SPEC.		
REDRAWN ON CAD		
	APPV'D.	
	CHG'D.	
	ECN NO.	
	SYM.	