

Installation Instructions for the Magnetoresistive Sensor ICs Nanopower Series

50094459

Issue C

Table 1A. Electrical Specifications (Vs = 1.65 V to 5.5 V, Ta = -40 °C to 85 °C [-40 °F to 185 °F], Typ. at 1.8 V, 25 °C [77 °F] unless otherwise specified.)

Characteristic	Condition	Min.	Typ.	Max.	Unit
Supply voltage (Vs)	Vs reference to ground	1.65	1.8	5.5	V
Awake current: SM351LT SM353LT	—	— 0.3	1 0.8	5 5	mA
Awake time	—	—	15	—	µs
Sleep current	—	—	0.2	8	µA
	Vs = 1.65 V	—	0.16	0.8	
	Vs = 1.8 V	—	0.2	1	
	Vs = 5.5 Vdc	—	2.6	8	
Sleep time	—	30	100	180	ms
Average current: SM351LT SM353LT	0.015% duty cycle, typ.	—	360	6640	nA
		—	310	6350	
Output voltage: low (VoL) high (VoH)	load current = 100 µA	0	0.03	0.15	V
		Vs - 0.15	Vs - 0.03	Vs	

NOTICE

These magnetoresistive sensor ICs may have an initial output in either the ON or OFF state if powered up with an applied magnetic field in the differential zone (applied magnetic field >Brp and <Bop). Honeywell recommends allowing 10 µs for output voltage to stabilize after supply voltage has reached its final rated value.

Table 1B. Electrical Specifications (Vs = 1.8 V, Ta = 25 °C [77 °F].)

Characteristic	Condition	Min.	Typ.	Max.	Unit
Awake current: SM351LT SM353LT	—	— —	1 0.8	1.12 0.87	mA
Awake time	—	—	15	—	µs
Sleep current	—	—	0.2	0.59	µA
Sleep time	—	90	100	120	ms
Average current: SM351LT SM353LT	0.015% duty cycle, typ.	—	350	620	nA
		—	350	600	

NOTICE

The sensor will turn LOW when the magnetic field is present and switch to HIGH when the field is removed. The sensor will latch and hold the state during the sleep "mode".

Magnetostrictive Sensor ICs

Nanopower Series

Issue C
50094459

Table 2. Magnetic Specifications ($V_s = 1.65\text{ V}$ to 5.5 V , $T_a = -40\text{ }^\circ\text{C}$ to $85\text{ }^\circ\text{C}$ [$-40\text{ }^\circ\text{F}$ to $185\text{ }^\circ\text{F}$])

Characteristic	Min.	Typ.	Max.	Unit
SM351LT:				
operate (positive)	3	7	11	Gauss
release (positive)	2	5	—	
hysteresis	*	2	—	
SM353LT:				
operate (positive)	6	14	20	Gauss
release (positive)	3	10	—	
hysteresis	*	4	—	

*At 1.65 V and $-40\text{ }^\circ\text{C}$, the hysteresis can reach 0.1 Gauss.

NOTICE

The magnetic field strength (Gauss) required to cause the switch to change state (operate and release) will be as specified in the magnetic characteristics. To test the switch against the specified magnetic characteristics, the switch must be placed in a uniform magnetic field.

Table 3. Absolute Maximum Ratings

Characteristic	Condition	Min.	Typ.	Max	Unit
Operating temperature	ambient	-40 [-40]	—	85 [185]	$^\circ\text{C}$ [$^\circ\text{F}$]
Soldering temperature	ambient applied for $<10\text{ s}$	—	—	265 [509]	$^\circ\text{C}$ [$^\circ\text{F}$]
Supply voltage (V_s)	—	-0.5	—	6	V
Output (load) current	—	—	—	5	mA

NOTICE

Absolute maximum ratings are the extreme limits that the device will withstand without damage to the device. However, the electrical and mechanical characteristics are not guaranteed as the maximum limits (above recommended operating conditions) are approached, nor will the device necessarily operate at absolute maximum ratings.



Figure 1. Block/Electrical Diagram

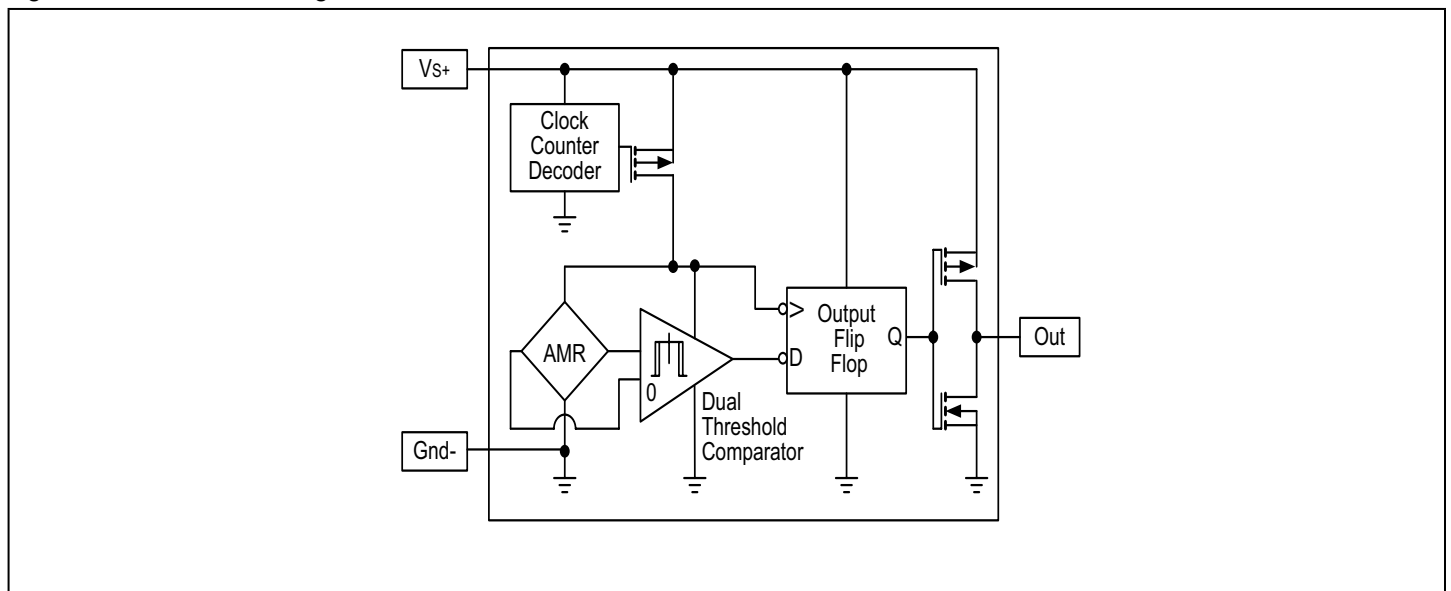

Magneto-resistive Sensor ICs Nanopower Series

Issue C
50094459

Figure 2. Alignment of the Magnet to the Omnipolar Magneto-resistive Sensor IC

Ideal alignment: The magnet is aligned in the same plane as the sensor IC.

The magnetic flux lines stay horizontal as the magnet approaches the sensor IC (see Figure 2.A).

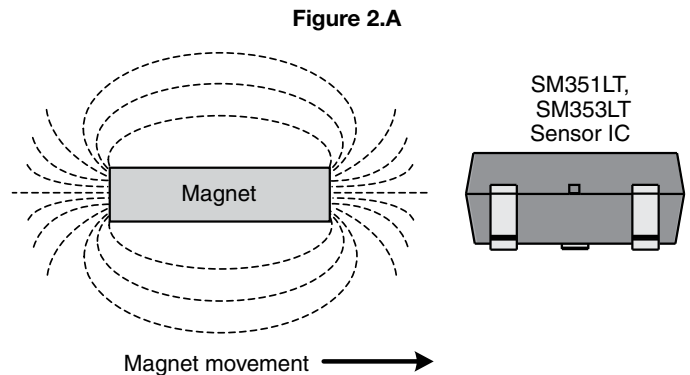

Offset alignment: The magnet is not aligned in the same plane as the sensor IC.

Parallel magnet approach to the sensor IC may cause dead zones.

Dead zones may occur when the majority of the magnet's magnetic flux lines become vertical as it approaches the sensor IC, turning the sensor IC to ON, then OFF, then ON (see Figure 2.B).

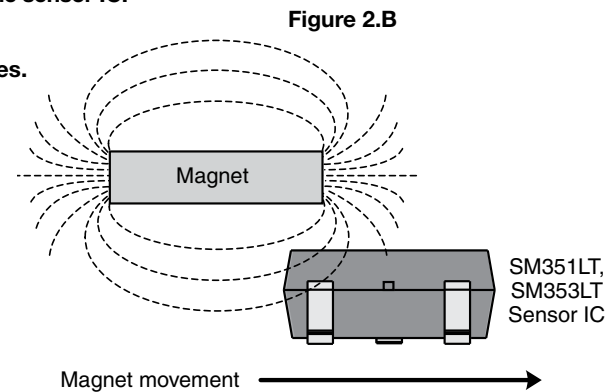

Perpendicular magnet approach to the sensor IC eliminates possible dead zones.

The sensor IC detects the approaching magnet's horizontal magnetic flux lines, turning the sensor IC to ON. The sensor IC stays ON as the magnet continues to approach. When the magnet is located directly over the sensor IC, all magnetic flux lines are now horizontal (see Figure 2.C). Note: This alignment decreases the magnetic flux strength at the sensor IC.

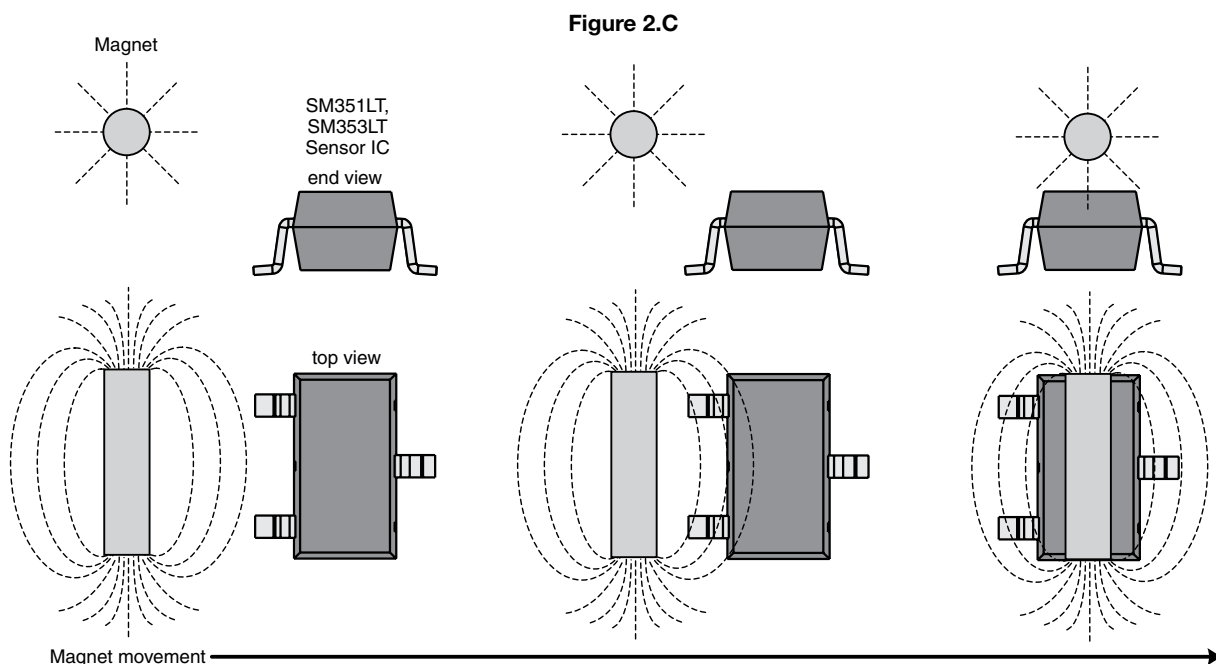

Figure 3. SM351LT Typical Performance Characteristics

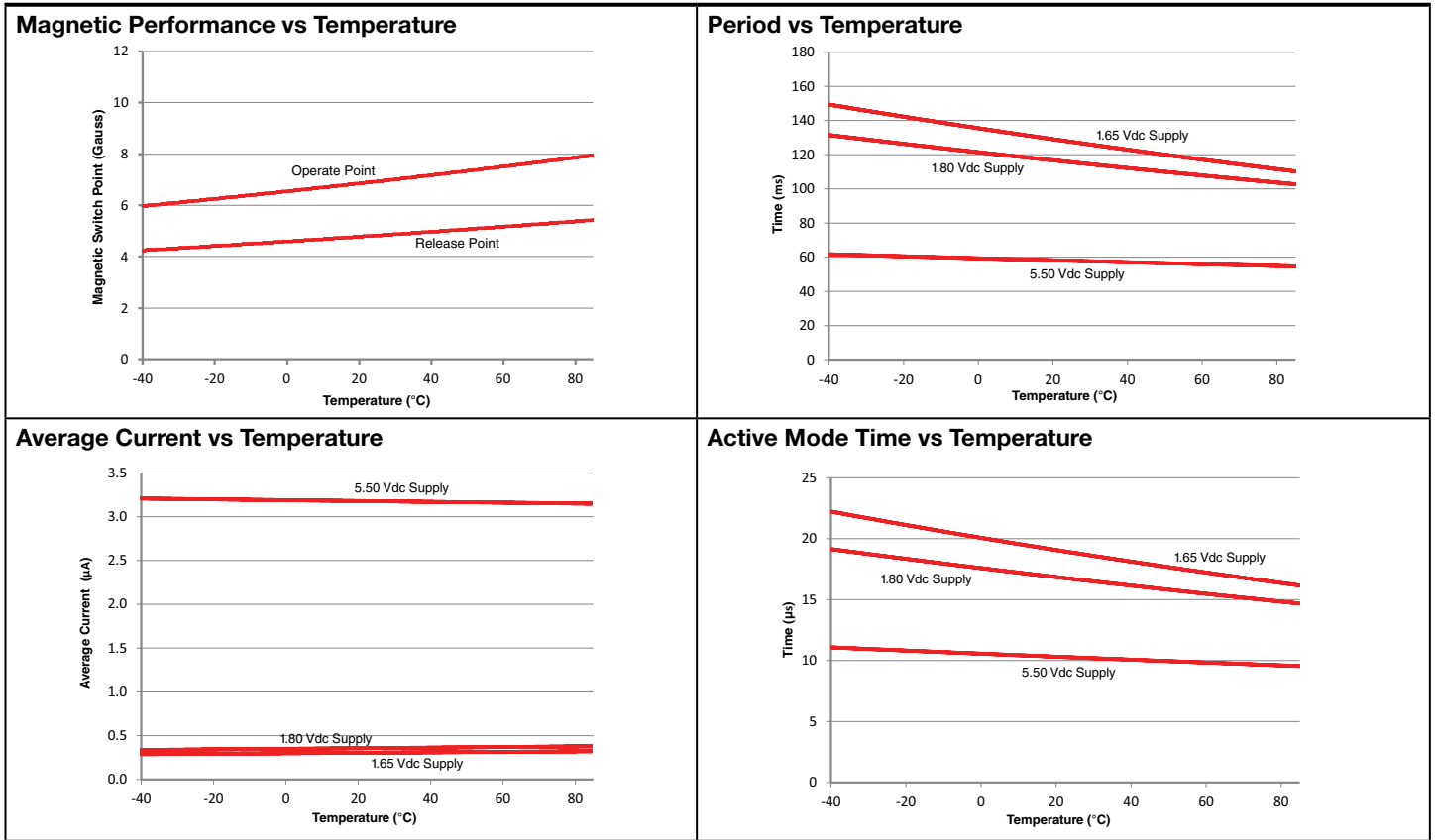
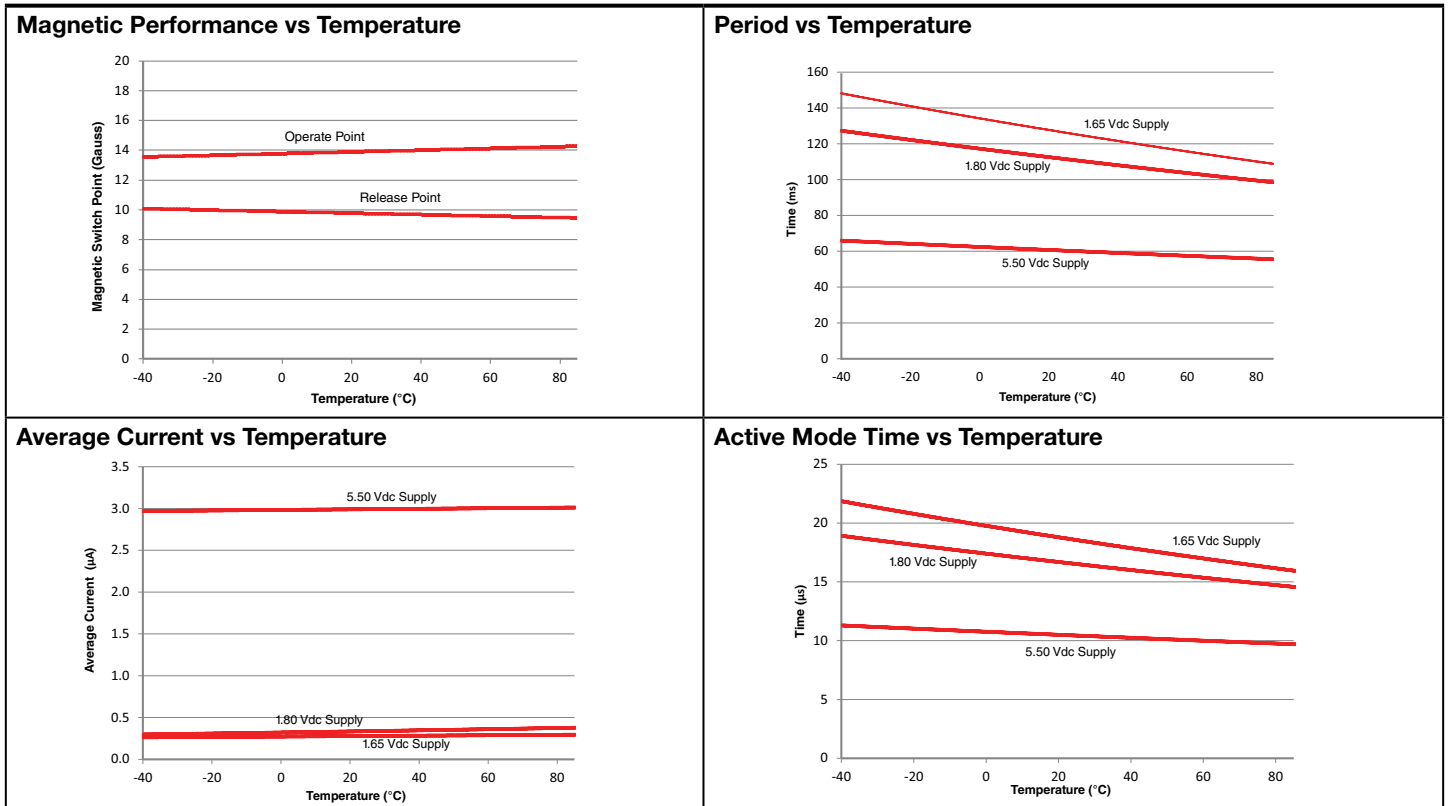

Figure 4. SM353LT Typical Performance Characteristics



Magnetoresistive Sensor ICs Nanopower Series

Issue C
50094459

Figure 5. Mounting and Tape/Reel Dimensions (For reference only. mm/[in.])

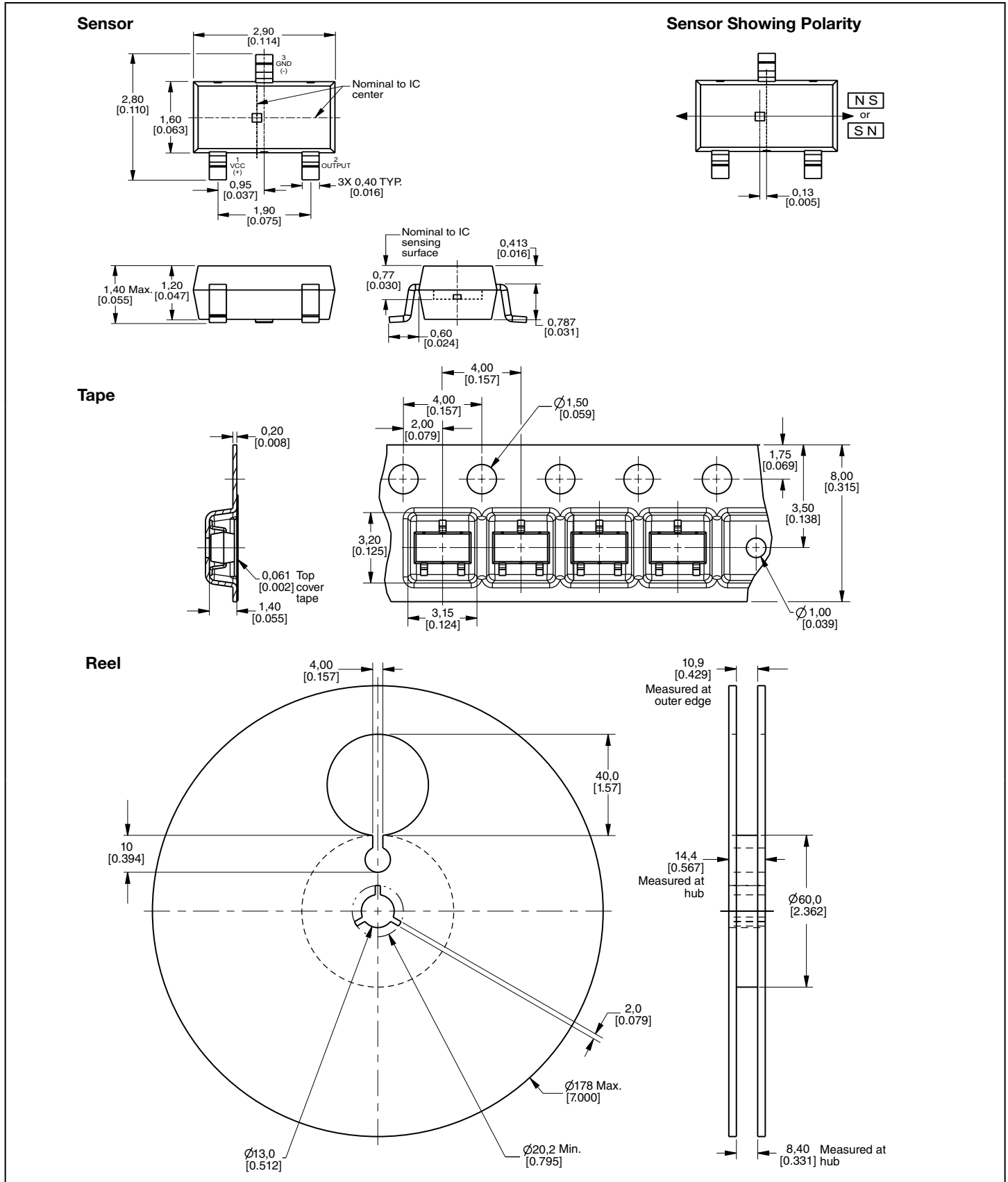

Magnetoresistive Sensor ICs

Nanopower Series

Issue C
50094459

⚠ WARNING

PERSONAL INJURY

DO NOT USE these products as safety or emergency stop devices or in any other application where failure of the product could result in personal injury.

Failure to comply with these instructions could result in death or serious injury.

WARRANTY/REMEDY

Honeywell warrants goods of its manufacture as being free of defective materials and faulty workmanship. Honeywell's standard product warranty applies unless agreed to otherwise by Honeywell in writing; please refer to your order acknowledgement or consult your local sales office for specific warranty details. If warranted goods are returned to Honeywell during the period of coverage, Honeywell will repair or replace, at its option, without charge those items it finds defective. **The foregoing is buyer's sole remedy and is in lieu of all other warranties, expressed or implied, including those of merchantability and fitness for a particular purpose. In no event shall Honeywell be liable for consequential, special, or indirect damages.**

While we provide application assistance personally, through our literature and the Honeywell web site, it is up to the customer to determine the suitability of the product in the application.

Specifications may change without notice. The information we supply is believed to be accurate and reliable as of this printing. However, we assume no responsibility for its use.

Honeywell serves its customers through a worldwide network of sales offices, representatives and distributors. For application assistance, current specifications, pricing or name of the nearest Authorized Distributor, contact your local sales office or:

E-mail: info.sc@honeywell.com

Internet: sensing.honeywell.com

Phone and Fax:

USA/Canada +1-800-537-6945

International +1-815-235-6847; +1-815-235-6545 Fax