

## 20PC SMT Pressure Sensors Common Mode Auto Referencing

### INTRODUCTION

Pressure sensors are not “ideal” devices. Laser trimming on Honeywell Sensing and Control devices reduces null and span errors, but does not completely eliminate them. Additional corrective circuitry is sometimes necessary for applications with extremely tight tolerances.

A family of techniques known as auto-zeroing provides a powerful tool. Implementation costs are minor in comparison with ultra-stable pressure sensors. Device accuracy is also substantially increased.

If sensor interface is through an analog-to-digital converter to a microprocessor, auto-zeroing can be easily implemented with a software routine that redefines the digital representation of the null condition. The function must be synchronized to activate only at system null. This application sheet illustrates low cost circuit hardware techniques to be used when a microprocessor is not used in the measurement system.

There are many options, design criteria and tradeoffs with respect to auto-zero circuits.

### CIRCUIT TYPES

There are two basic types of pressure sensors from Honeywell Sensing and Control — amplified and sensor-only. Thus, two criteria were selected.

- Unity gain amplifier for amplified pressure sensors with single ended input (40PC, 140PC, 160PC, 180PC, 240PC and micro-bridge airflow sensors).
- Built-in amplification for sensor-only listings with differential input (20PC, 130PC, 170PC and 230PC types).

### OPTIONS

- Auto-zero all initial system error sources without manual adjustment.
- Manually trim for initial null errors, auto-zero for system null drift.

### FUNCTIONALITY

The circuits shown in this application note have analog inputs from the sensors and analog outputs. Two supply voltage connections are required ( $V_s$  and GND). A digital input signal is required to enable the auto-zero function to be synchronized such that it is only enabled when the sensed medium is at the null condition. When enabled, the up/down counter will automatically count (increment/decrement) in the direction required to modify the analog output voltage to equal the

desired null voltage independent from the null voltage produced from the sensor. The desired null voltage is set with a resistor voltage divider. When the analog output voltage is within the least significant bit value of the desired divider voltage, the counter will toggle up and down, and the zeroing is complete. Since only the null is adjusted, the full-scale value will also change by the same amount as was corrected for the null. Thus, the span does not change. The counter will hold the corrected null value count when the enable signal is switched “off.”

A four bit counter will adjust the null to within approximately 1/15 (0.0667) of its maximum error range. For example, an amplified sensor with a  $0.5 \pm 0.04$  volt output can be zeroed to about  $0.5 \pm 0.005$  volts ( $0.04 \times 2 \div 15$ ). For best accuracy, the null divider can be actively trimmed to eliminate op amp input offset errors. An eight bit counter (made from two four bit counters, an additional IC) will decrease the error range by approximately 250 times.

### CIRCUITRY FEATURES

Linear amplification, interface to counter, and wide sensor null manual trim correction ability have been accomplished with two op amps. The clock and comparator functions were implemented with the other two op amps of the quad, eliminating two ICs.

Accuracy can be improved by adding an additional low cost counter.

When the auto-zero function is not enabled, the clock is disabled to avoid creating digital voltage spikes within the analog circuitry. The comparator is also disabled to avoid any possible switching spikes at null.

The MC14516B 4-bit binary up/down counter IC is used because of the allowable power supply voltage range of 3 to 18 volts (universal applications). The quad LM6134 op amp is used for its speed in order to produce the clock and comparator functions, and for the unusual ability to operate close to the supply rails for both inputs and outputs. Thus, 0.5 volt null and 4.5 volt full scale with a five volt supply can be achieved for 40PC applications along with ten volt sensor-only designs using the same counter and op amp ICs. A dual diode device packaged in a single SOT-23 transistor package such as Motorola BAV70LT1, can be used to save board space.

## CIRCUIT 1 SCHEMATIC

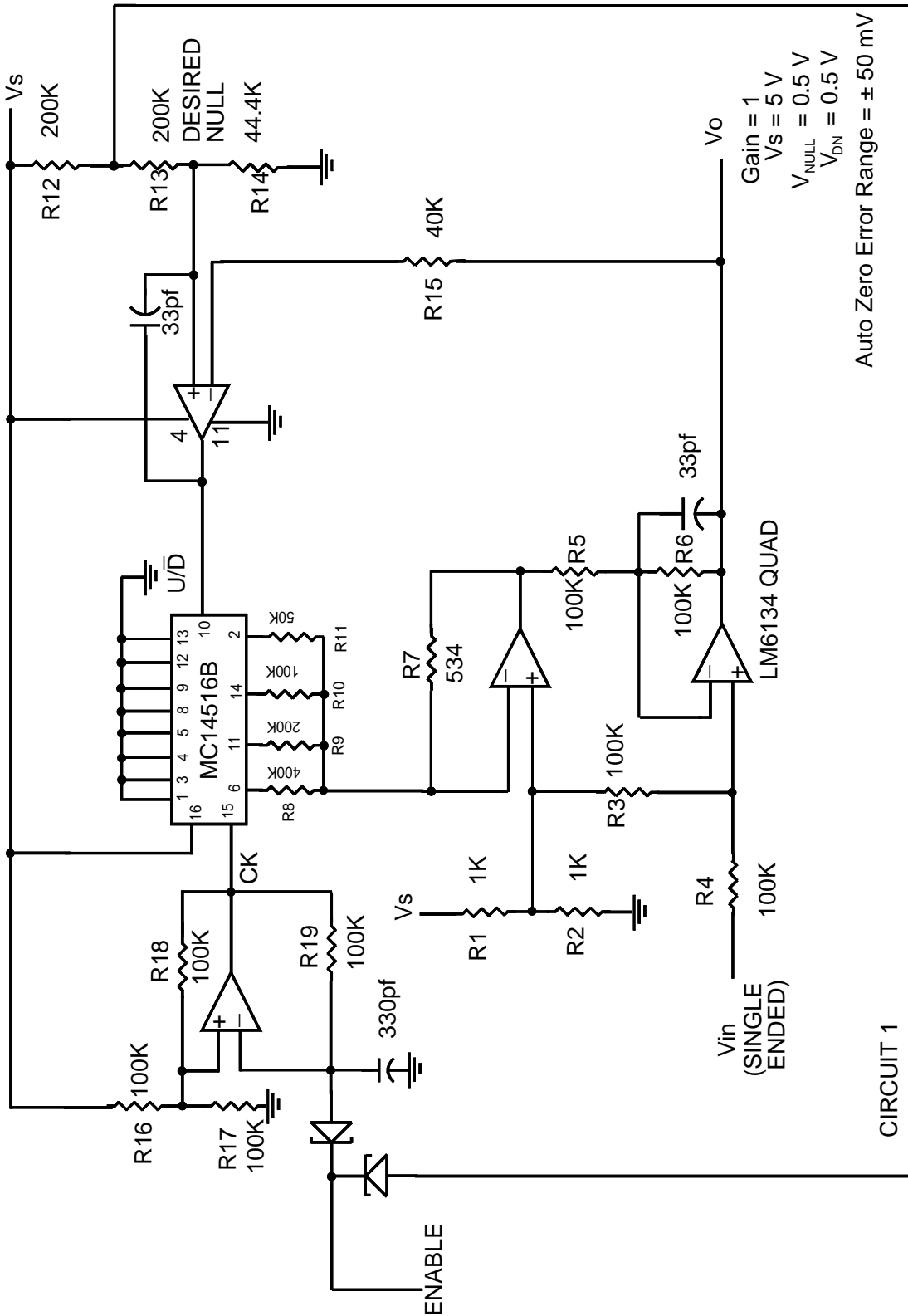

## CIRCUIT 1 DESCRIPTION

\* Application: 40PC

Input to auto-zero circuit:

$$V_S = 5 \text{ volts}$$

$$V_{NULL} = 0.5 \pm 0.04 \text{ volts } (\pm 1\% \text{ of span})$$

$$V_{FULLSCALE} = 4.5 \text{ volts nominal}$$

Auto-zero circuit:

4 bit counter

Unity gain

$$V_{NULL} = 0.5 \pm 0.006 \text{ volts } (\pm 0.15\% \text{ of span})$$

$$V_{FULLSCALE} = 4.5 \text{ volts nominal}$$

Input null = 0.5 V Nominal

Input full scale = 4.5 V Nominal

Output correction resolution = 6.25 mV

### Transfer function

$$V_O = V_{IN} + V_{OS} + V_{AZ}$$

Where:

$V_{OS}$  = Input offset errors of op amps and other error sources due to resistor mismatch, etc.

$V_{AZ}$  = Auto-zero correction voltage

And:

$$V_{AZ(MAX)} = \frac{V_S}{2} (R_7 / R_C)$$

$$V_{AZ(MIN)} = -\frac{V_S}{2} (R_7 / R_C)$$

$$V_{AZ(RANGE)} = V_S (R_7 / R_C)$$

$$V_{AZ(RESOLUTION)} = \frac{V_S}{2^N} (R_7 / R_C)$$

N = number of counter bits (4)

$V_S$  = Supply Voltage

$$R_C = \frac{1}{\frac{1}{R_8} + \frac{1}{R_9} + \frac{1}{R_{10}} + \frac{1}{R_{11}} + \dots + \frac{1}{R_X}}$$

$$R_1 = R_2$$

$$R_3 = R_4 = R_5 = R_6$$

$$R_3 \gg R_1$$

And,

$$V_{DESIRED \ NULL} = V_S \frac{R_{14}}{R_{12} + R_{13} + R_{14}}$$

**NOTE:**  $V_{DESIRED \ NULL}$  can be trimmed to eliminate comparator offset errors.

\*Circuit resistor values can be modified for 8-volt devices, such as 140PC, 160PC, 180PC, and 240PC.

# 20PC Common Mode Auto Referencing

Technical Note

CIRCUIT 2 SCHEMATIC

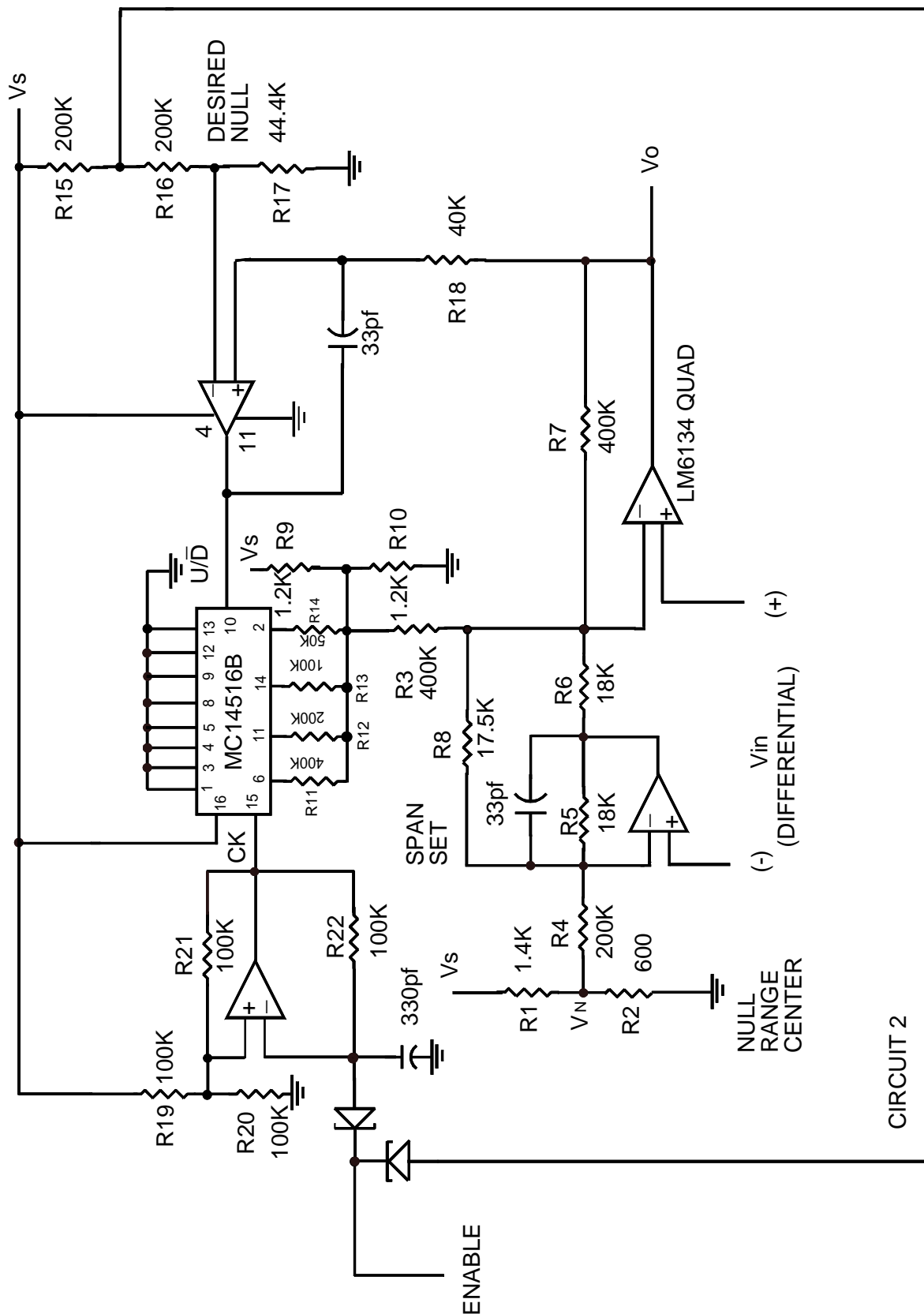

## CIRCUIT 2 DESCRIPTION

Application: 26PC

Input to auto-zero circuit:

$V_S = 10$  volts

$V_{NULL} = 0 \pm 1.5$  millivolts ( $\pm 1.5\%$  of span)

$V_{FULLSCALE} = 100$  millivolts nominal

Auto-zero circuit:

4 bit counter

Gain = 70

$V_{NULL} = 1.0 \pm 0.014$  volts ( $\pm 0.2\%$  of span)

(without auto-zeroing,  $\pm 0.105$  volts not including op amp errors)

$V_{FULLSCALE} = 8$  volts nominal

## Amplified, 4 bit, 10 V auto-zero circuit for 26PC type sensors

Gain = 70

$V_S = 10$  V

$V_{NULL} = 1.0$  V (Nominal output)

$V_N = 3$  V

$V_{DN} = 1$  V

Auto-zero output error range =  $\pm 110$  mV

Full Scale input = +100 mV

Output full scale = 8 V

Input null =  $\pm 1.5$  mV

Output correction resolution = 13.8 mV

### Transfer function:

$$V_O = (V_{IN} + V_{OS1})[2 + R_7(\frac{1}{R_6} + \frac{2}{R_8})] + 2V_N - V_{AZ} + V_{OS2}$$

Thus:

$$\text{Nominal Gain} = 2 + R_7(\frac{1}{R_6} + \frac{2}{R_8})$$

$$\text{Nominal Null} = 2V_N - V_{AZ}$$

$$\text{Nominal } V_{AZ} = \frac{V_S}{2}$$

Where:

$V_{OS1}$  = Input offset error due to op amps

$V_{OS2}$  = Circuit errors that are not amplified

### NOTE:

$V_N$  can be trimmed to eliminate transfer function component offset errors of the auto-zero module. Also,  $V_N$  could be trimmed in conjunction with a particular sensor to eliminate initial sensor offset errors. If  $V_N$  is not trimmed, all errors including circuit and sensor must be included in the auto-zero range calculation, which will decrease the resolution.

$V_{AZ}$  = auto-zero correction voltage

$R_5 = R_6$

$R_3 = R_7$

$R_4 = \frac{R_7}{2}$

$R_9 = R_{10}$

For best amplifier common mode rejection:

$$\frac{1}{R_3 + \frac{R_9 R_{10}}{R_9 + R_{10}}} + \frac{1}{R_7} = \frac{1}{R_4 + \frac{R_1 R_2}{R_1 + R_2}}$$

OR:

$$\frac{R_9 R_{10}}{R_9 + R_{10}} \ll R_3$$

and,

$$\frac{R_1 R_2}{R_1 + R_2} \ll R_4$$

$$V_{AZ(RANGE)} = \frac{V_S}{\frac{2R_C}{R_9} + 1}$$

$$V_{AZ(RESOLUTION)} = \frac{V_{AZ(RANGE)}}{2^N}$$

N = Number of counter bits (4)

$V_S$  = Supply voltage

$$R_C = \frac{1}{\frac{1}{R_{11}} + \frac{1}{R_{12}} + \frac{1}{R_{13}} + \frac{1}{R_{14}} + \dots + \frac{1}{R_X}}$$

$$V_{DESIRED NULL} = V_S \frac{R_{17}}{R_{15} + R_{16} + R_{17}}$$

### NOTE:

$V_{DESIRED NULL}$  can be trimmed to eliminate comparator amp offset error.

# 20PC Common Mode Auto Referencing

Technical Note

CIRCUIT 3 SCHEMATIC

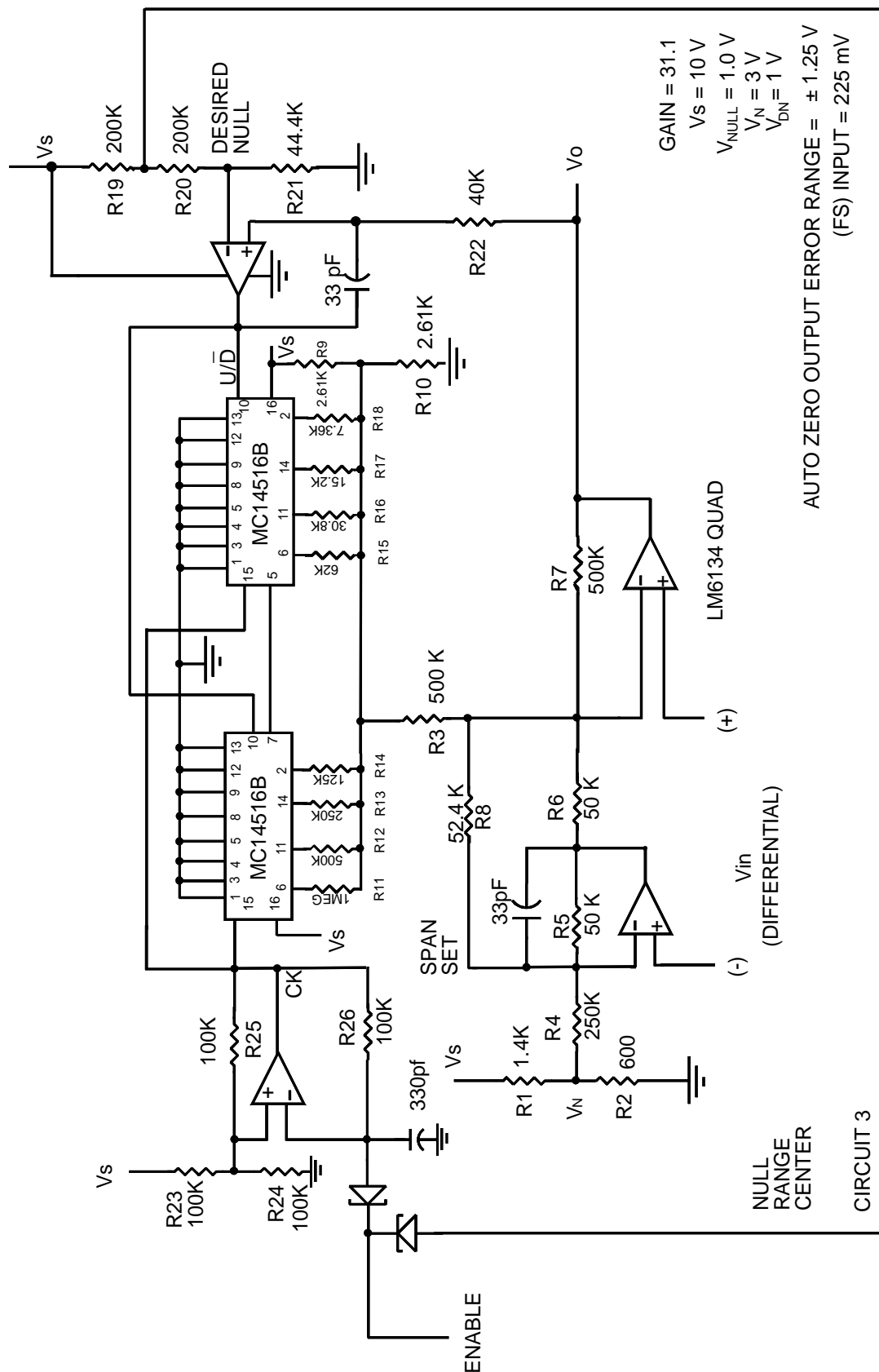

## CIRCUIT 3 DESCRIPTION

Application: 22PC, 24PC

Input to auto-zero circuit:

$$V_S = 10 \text{ volts}$$

$$V_{NULL} = 0 \pm 30 \text{ mV } (\pm 13.3\% \text{ of span})$$

$$V_{FULLSCALE} = 225 \text{ mV nominal}$$

Auto-zero circuit:

8 bit counter

Gain = 31.1

$$V_{NULL} = 1.0 \pm 0.010 \text{ volts } (\pm 0.14\% \text{ of span})$$

(without auto-zero  $\pm 0.933$  volts, not including op amp errors)

$$V_{FULLSCALE} = 8.0 \text{ volts nominal}$$

### Amplified 8 bit, 10 V auto-zero circuit for 24PC type sensors (no temperature compensation)

Output full scale = 8 V

Input null =  $\pm 30$  mV

Output correction resolution = 10 mV

### Transfer Function

$$V_O = (V_{IN} + V_{OS1})[2 + R_7(\frac{1}{R_6} + \frac{2}{R_8})] + 2V_N - V_{AZ} + V_{OS2}$$

Thus:

$$\text{Nominal Gain} = 2 + R_7(\frac{1}{R_6} + \frac{2}{R_8})$$

$$\text{Nominal Null} = 2V_N - V_{AZ}$$

$$\text{Nominal } V_{AZ} = \frac{V_S}{2}$$

Where:

$V_{OS1}$  = Input offset error due to op amps and sensor.

$V_{OS2}$  = Circuit errors that are not amplified.

### NOTE:

$V_N$  can be trimmed to eliminate transfer function component offset errors of the auto-zero module. Also,  $V_N$  could be trimmed in conjunction with a particular sensor to eliminate initial sensor offset errors. If  $V_N$  is not trimmed, all errors including circuit and sensor must be included in the auto-zero range calculation, which will decrease the resolution.

$V_{AZ}$  = Auto-zero correction voltage

$$R_5 = R_6$$

$$R_3 = R_7$$

$$R_4 = \frac{R_7}{2}$$

$$R_9 = R_{10}$$

For best amplifier common mode rejection:

$$\frac{1}{R_3 + \frac{R_9 R_{10}}{R_9 + R_{10}}} + \frac{1}{R_7} = \frac{1}{R_4 + \frac{R_1 R_2}{R_1 + R_2}}$$

For application help: call 1-800-537-6945

Or

$$\frac{R_9 R_{10}}{R_9 + R_{10}} \ll R_3$$

And

$$\frac{R_1 R_2}{R_1 + R_2} \ll R_4$$

Then:

$$\frac{1}{R_3} + \frac{1}{R_7} = \frac{1}{R_4}$$

and,

$$V_{AZ(RANGE)} = \frac{V_S}{\frac{2R_C}{R_9} + 1}$$

$$V_{AZ(RESOLUTION)} = \frac{V_{AZ(RANGE)}}{2^N}$$

N = Number of counter bits (8)

$V_S$  = Supply voltage

$$R_C = \frac{1}{\frac{1}{R_{11}} + \frac{1}{R_{12}} + \frac{1}{R_{13}} + \frac{1}{R_{14}} + \frac{1}{R_{15}} + \dots + \frac{1}{R_X}}$$

$$V_{DESIRED \text{ NULL}} = V_S \frac{R_{21}}{R_{19} + R_{20} + R_{21}}$$

### NOTE:

$V_{DESIRED \text{ NULL}}$  can be trimmed to eliminate comparator amp offset error.

# 20PC Common Mode Auto Referencing

Technical Note

CIRCUIT 4 SCHEMATIC

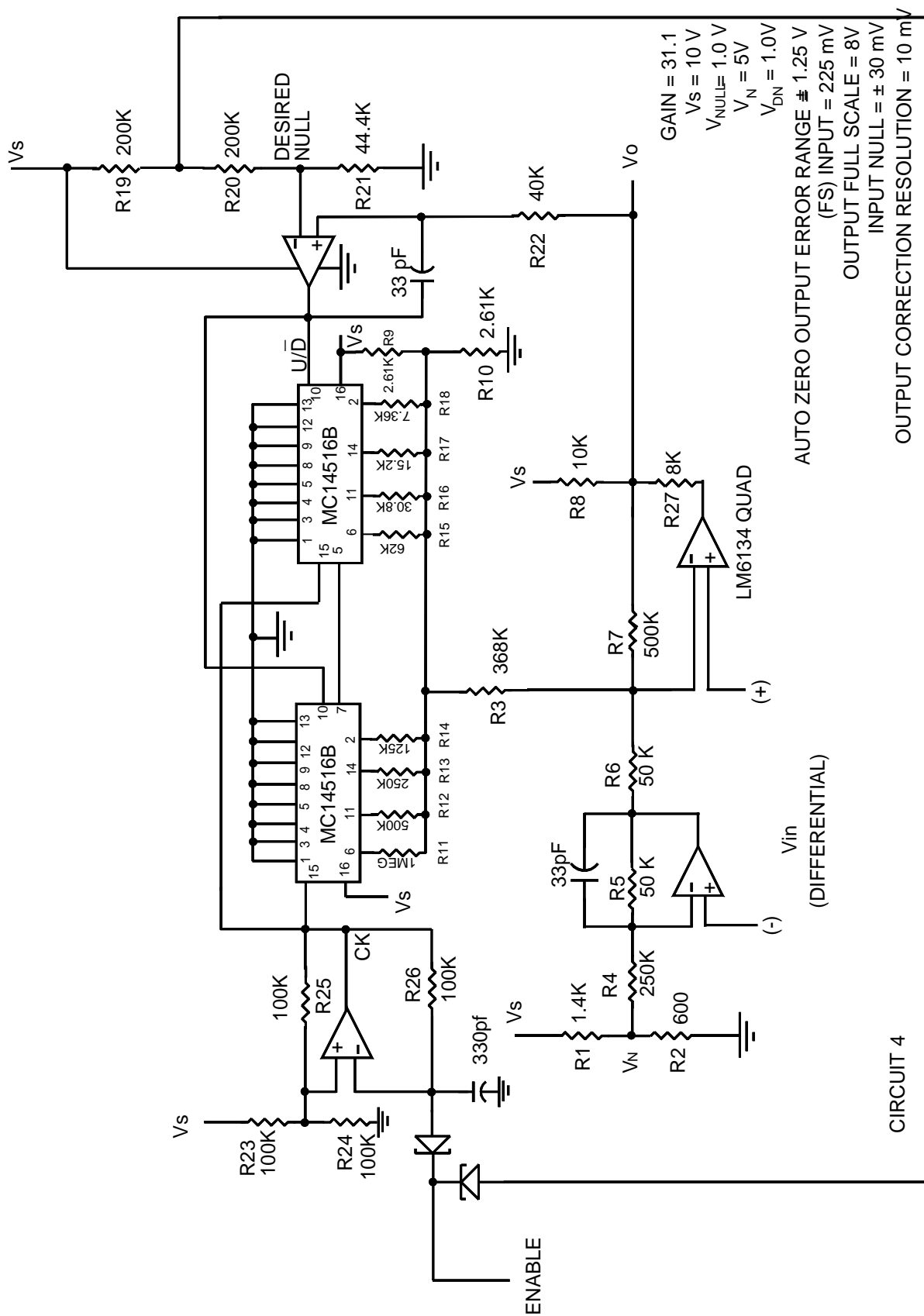



## CIRCUIT 4

Application: 22PC, 24PC

Circuit 4 is the same as Circuit 3, except for a modification that will allow the span (gain) to be trimmed independently from interactions with the null for improved manufacturability. This requires a special trim procedure and internal voltage measurements.

**Amplified 8 bit, 10 V auto-zero circuit for 24PC type sensors (no temperature compensation), independent span trim.**

**Transfer function:**

$$V_O = (V_{IN} + V_{OS1})(R_3)\left(\frac{1}{R_4} + \frac{1}{R_6}\right) + V_N \frac{R_3}{R_4}$$

$$-V_{AZ} - V_S \frac{R_{27}}{R_8} + V_{OS2}$$

Where:

$$R_5 = R_6$$

$$\frac{R_{27}}{R_8} = 1 - \frac{2V_{NULL}}{V_S} \quad (\text{for } V_{R7} = 0 @ \text{Null})$$

$$1 + \frac{R_7}{R_3} = \frac{R_7}{R_4} + \frac{1}{R_7\left(\frac{1}{R_8} + \frac{1}{R_{27}}\right) + 1} \quad (\text{for CMR})$$

$$\left[R_{27}\left(\frac{1}{R_7} + \frac{1}{R_8}\right) + 1\right] \frac{R_7}{R_3} = 1 \quad (\text{coefficient of } V_{AZ})$$

$$\text{Gain} = R_3\left(\frac{1}{R_4} + \frac{1}{R_6}\right)$$

Using the above, the resistor calculations are:

Pick  $R_7, R_8$

$$R_{27} = R_8\left(1 - \frac{2V_{NULL}}{V_S}\right)$$

$$R_3 = R_7\left[R_{27}\left(\frac{1}{R_7} + \frac{1}{R_8}\right) + 1\right]$$

$$R_4 = \frac{R_7}{\frac{R_2 - R_{27}}{R_3} + 1}$$

$$R_6 = R_5 = \frac{R_3}{\text{GAIN} - \frac{R_3}{R_4}}$$

and:

$V_{OS1}$  = Input offset error due to op amps and sensor.

$V_{OS2}$  = Circuit errors that are not amplified.

## NOTE:

To actively trim span, trim  $V_N$  ( $R_1$  or  $R_2$ ) until the voltage across  $R_7$  is zero. Measure  $V_O$  at null pressure. Add desired span voltage to measured  $V_{ONULL}$ . Apply pressure. Trim  $R_7$  until  $V_O$  is equal to calculated value. Remove pressure input. Trim  $V_N$  until  $V_O$  is at desired null value.

$V_{AZ}$  = auto-zero correction voltage

$$V_{AZ(\text{RANGE})} = \frac{V_S}{\frac{2R_C}{R_9} + 1}$$

$$V_{AZ(\text{RESOLUTION})} = \frac{V_{AZ(\text{RANGE})}}{2^N}$$

$N$  = Number of counter bits (8)

$V_S$  = Supply voltage

$$R_C = \frac{1}{\frac{1}{R_{11}} + \frac{1}{R_{12}} + \frac{1}{R_{13}} + \frac{1}{R_{14}} + \dots + \frac{1}{R_X}}$$

$$V_{\text{DESIRED NULL}} = V_S \frac{R_{21}}{R_{19} + R_{20} + R_{21}}$$

## NOTE:

$V_{\text{DESIRED NULL}}$  can be trimmed to eliminate comparator amp offset errors.

NOTES PAGE

NOTES PAGE

## WARRANTY/REMEDY

Honeywell warrants goods of its manufacture as being free of defective materials and faulty workmanship. Contact your local sales office for warranty information. If warranted goods are returned to Honeywell during the period of coverage, Honeywell will repair or replace without charge those items it finds defective. The foregoing is Buyer's sole remedy and is **in lieu of all other warranties, expressed or implied, including those of merchantability and fitness for a particular purpose.**

For application assistance, current specifications, pricing or name of the nearest Authorized Distributor, contact a nearby sales office. Or call:  
1-800-537-6945 USA  
1-800-737-3360 Canada  
1-815-235-6847 International

## FAX

1-815-235-6545 USA

## INTERNET

<http://www.sensing.honeywell.com>  
[info.sc@honeywell.com](mailto:info.sc@honeywell.com)

Specifications may change without notice. The information we supply is believed to be accurate and reliable as of this printing. However, we assume no responsibility for its use.

While we provide application assistance personally, through our literature and the Honeywell web site, it is up to the customer to determine the suitability of the product in the application.

---

# Honeywell

**Sensing and Control**  
Honeywell  
11 West Spring Street  
Freeport, Illinois 61032



Printed with Soy Ink  
on 50% Recycled Paper

008065-1-EN IL50 GLO 601 Printed in USA

[www.honeywell.com/sensing](http://www.honeywell.com/sensing)