

# Model GM



## SIGNAL CONDITIONER-INDICATOR INSTRUCTION MANUAL

# SENSOTEC



## TABLE OF CONTENTS

	<b>Subject</b>	<b>Page</b>
1.0	Introduction .....	2
2.0	Description .....	2
2.1	Configuration .....	2
2.2	Specifications .....	3
3.0	Unpacking, Installation and Wiring .....	4
3.1	Selecting Excitation Voltage .....	4
3.2	Mounting the Unit .....	4
3.3	Wiring to the Sensor .....	5
3.4	Wiring the Output .....	5
3.5	Wiring to the Optional Limits .....	5
3.6	Wiring to the Optional Peak Detector .....	6
3.7	Wiring to the Optional Track-and-Hold Unit .....	6
3.8	Power Connections .....	7
4.0	Initial Adjustments/Setup .....	7
4.1	Zero Adjustment .....	7
4.2	Span Adjustment .....	7
4.2.1	Span Adjustment, with Shunt Calibration .....	7
4.2.2	Span Adjustment, without Shunt Calibration .....	9
4.3	Scaling Adjustment .....	9
5.0	Operative Adjustments .....	10
5.1	Fine Zero Adjustments .....	10
5.2	Fine Span Adjustments .....	10
6.0	Changing the Shunt Calibration Resistor .....	10
7.0	Options .....	12
7.1	High/Low Limits Option .....	12
7.1.1	Setting the Limits Adjustments .....	12
7.1.2	Limit Polarity and Hysteresis .....	13
7.2	Peak Detector Option .....	13
7.3	Track-and-Hold Option .....	14
8.0	Troubleshooting Guide .....	14
9.0	Drawings .....	15
10.0	Warranty/Repair Policy .....	15
10.1	Limited Warranty on Products .....	15
10.2	Obtaining Service Under Warranty .....	15
10.3	Obtaining Non-Warranty Service .....	15
10.4	Repair Warranty .....	16
11.0	Glossary of Signal Conditioning Terms .....	16

# SENSOTEC MODEL GM SIGNAL CONDITIONER-INDICATOR

## 1.0 Introduction

The SENSOTEC Model GM Signal Conditioner-Indicator is a complete 4½ digit signal conditioner and indicator housed in a 1/8 DIN case. This unit provides many of the features found on expensive, larger signal conditioning units:

- Full 4½ digit, 0.56-inch display
- Display in any engineering unit desired
- Full 20,000 count resolution
- Accepts strain-gage transducer inputs from 0.5 to 50 mv/v
- 0-5V output
- +/- 0.03% accuracy
- Compression type power and I/O connectors
- Shunt calibration from front-panel
- 1/8 DIN "panel meter size" case
- 5- or 10-volt transducer excitation
- Optional Dual Limits
- Optional Peak Detector
- Optional Track-and-Hold
- 110- or 220-V Power

## 2.0 Description

**2.1 Configuration.** Within the Model GM's enclosure there are three printed circuit boards (four if an option is selected). The Main Board contains the circuitry for the power supply and A/D converter. The Display Board contains all circuitry needed to drive the LED display and the units display bar. The Signal Conditioner Board contains circuitry for the signal amplifier and for the excitation power supply. The Display Board solders to the Main Board, whereas the Signal Conditioner Board plugs into it. If the Dual Limits, Peak Detector or Track-and-Hold option is supplied, a fourth plug-in board houses it. DUE TO SPACE CONSTRAINTS, ONLY ONE OPTION CAN BE INSTALLED ON A PARTICULAR UNIT. Adjustments for COARSE SPAN, FINE SPAN, COARSE ZERO, FINE ZERO, and SCALING are provided. FINE ZERO and FINE SPAN may be adjusted from the front panel without removing the front bezel. The entire unit may be quickly panel or rack mounted with the snap-on attachments supplied with every unit.

## 2.2 Specifications:

<b>GENERAL</b>	# Channels .....	1
	Case Material .....	Noryl Plastic
	Temperature Storage .....	-20° F to 200° F
	Temperature Operating .....	32° F to 130° F
<b>TRANSDUCER INTERFACE</b>	Transducer Excitation .....	5 or 10 VDC
	Type of inputs accepted .....	0.5 mv/v to 5.0 mv/v or 5 mv/v to 50 mv/v
	Transducer Current drive (ma.) ..	50
	Input Gain Range .....	10-1000
	Push Button Shunt Cal .....	Yes
	Calibration Method .....	Manual (front panel)
	Zero Balance .....	+/- 15% F.S. Min.
	Noise & Ripple .....	< 100 microvolts
	Transducer Minimum Impedance ..	350 $\Omega$ (10v Exc.)
<b>AMPLIFIER CHARACTERISTICS</b>	Full-Scale Output .....	5 Volts
	Output Impedance .....	< 2 ohms
	Accuracy .....	+/- 0.03%
	Frequency Response .....	> 100 Hz.
	Common Mode Rejection .....	> 80 dB.
	Fine Span Adjust .....	+/- 15%
	Coarse Span Adjust .....	> 80%
	Fine Zero Adjust .....	+/- 15%
	Coarse Zero Adjust .....	> 80%
	Short Circuit Protected .....	Yes
<b>DIGITAL DISPLAY CHARACTERISTICS</b>	# Characters Displayed .....	4-1/2
	Conversions per second .....	3
	Scaling .....	0-19999
	Scaling Method .....	Potentiometer
	Polarity Indication .....	"-" for Negative
	Decimal Pt. Selection .....	Jumper (non-solder)
	Display Size .....	0.56"
	Overrange Indication .....	Flashing display
	Resolution .....	1/20000
	Type .....	LED
<b>PHYSICAL CHARACTERISTICS</b>	Input/Output Connector .....	Screw Terminals
	Weight .....	2 lbs.
	Mounting .....	Bench, panel or rack
	DIN Size .....	1/8 DIN
<b>POWER SUPPLY</b>	Power Requirements .....	115VAC/220VAC (factory set, field changeable)
<b>FRONT PANEL</b>	Digital Display .....	4-1/2 digits LED
	Limit Condition .....	LEDs

### 3.0 Unpacking, Installation and Wiring

The Model GM is shipped in a single container. Inspect the unit for shipping damage, and gently shake and listen for loose components prior to energizing it. Report shipment damage to the carrier; it is his responsibility to safely transport the unit. If there is transportation damage and you have difficulty getting the problem resolved, contact SENSOTEC at (614) 486-7723. We will attempt to assist in resolving the situation.

### 3.1 Selecting Excitation Voltage

The Model GM provides a 5 or 10 VDC strain-gage transducer power supply. These units are normally set for 10 VDC at the factory. To check or change the excitation voltage, proceed as follows:

1. Remove the bezel and front panel with a small screwdriver.
2. Carefully pull the Main Board out of the unit. All boards will come out simultaneously.
3. Gently remove the vertical Signal Conditioner Board from the right edge of the Main Board and locate the two sets of three standoffs at the left end of this board. (See fig. 4, pg. 11.) Check the jumper location for excitation voltage setup.

#### 10 Volt Excitation

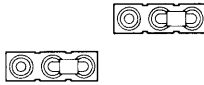

#### 5 Volt Excitation

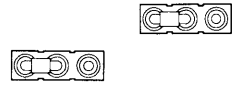

4. Replace the Signal Conditioner Board onto the Main Board and slide the board assembly into the case.
5. Reinstall the front panel and bezel.

### 3.2 Mounting the Unit

For panel mounting, cut a rectangular hole 3.58" in width by 1.73" in height. Remove the panel mounting brackets by unsnapping them from the sides of the Model GM. Place the Model GM through the panel cutout and reattach the panel mounting brackets to the sides of the case. Use a small screwdriver to tighten the panel mounting bracket adjusting screws until the case is pulled tightly into the panel.

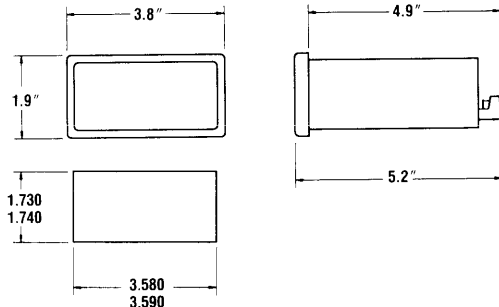

### 3.3 Wiring to the Sensor

All connections to the Model GM are made through the rear-panel 15-pin connector. Terminal 1 is AC HI; terminal 15 is + EXC. This connector may be separated from the GM for wiring by pulling on it gently. Connect the strain-gage sensor to the Model GM's last four terminals, marked + EXC., - EXC., + SIGNAL, and - SIGNAL. The transducer's (+) output and (-) output are wired to the Model GM's (+) SIGNAL and (-) SIGNAL terminals, respectively. The Model GM will accept strain-gage transducers with bridge impedances of 350 ohms or greater. Wires from the transducer may be pushed into the terminal using a small screwdriver.

**CAUTION:** The connector can be inserted incorrectly. Fluted side is down. Flat side is up! Incorrect insertion of this connector will result in extreme circuit damage.

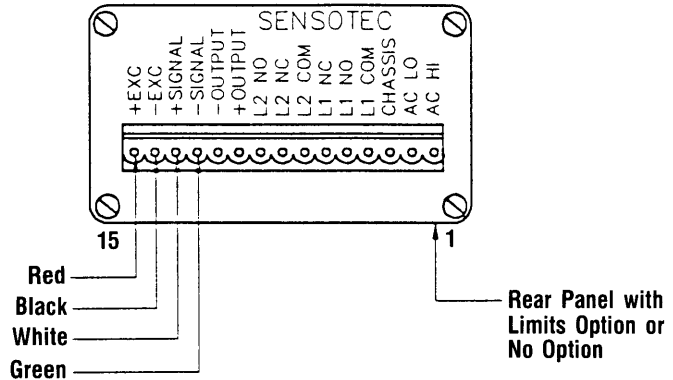

### 3.4 Wiring the Output

If the 0-5V output of the Model GM is to be used, wire to terminals 10 and 11, marked +OUTPUT and -OUTPUT. Observe the correct polarity.

### 3.5 Wiring to the Optional Limits

The Model GM utilizes relay output limits that are energized when the signal level exceeds the limit setting. The COMMON, NORMALLY OPEN, and NORMALLY CLOSED contacts for the L1 limit set are on terminals 4, 5 and 6 respectively and for the L2 limit set on terminals 7, 9 and 8. The relays are rated at 24 volts, 1.0 amp (non-inductive) or 48V, 0.5 amp (non-inductive).

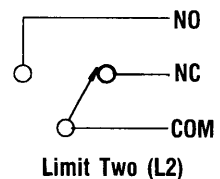
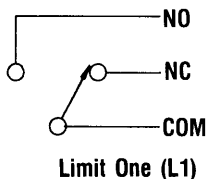

### 3.6 Wiring to the Optional Peak Detector

The Model GM is available with an optional peak detector module. This circuit will detect the highest **positive** value which has been attained since the peak detector was last reset. Reset may be accomplished by pressing the RST button on the front panel, or by interconnecting the RESET and COMMON terminals momentarily on the rear connector. Further, the PEAK OUT terminal will constantly monitor the peak detector output signal; the OUTPUT terminals will monitor the amplifier output normally, but will shift to monitor the output of the peak detector when one of two conditions occurs:

1. The front-panel PK button is pressed, or
2. The MODE SEL and COMMON terminals on the rear panel are interconnected.

The AMP OUT terminal continuously monitors amplifier output and is not affected by the peak detector.

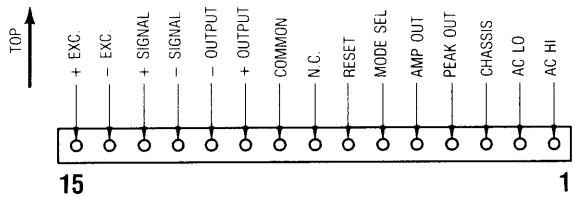

Rear Panel with Peak Option

### 3.7 Wiring to the Optional Track-and-Hold Unit

The Model GM is available with an optional Track-and-Hold unit. This circuit will permit the output signal to closely track the input signal until the HOLD function is engaged after which the last value obtained is held. The unit may be placed in "hold" by interconnecting the rear panel HOLD and COMMON terminals, or by switch action on the front panel. Placing the unit in "hold" will cause the output signal to lock on its last value prior to the "hold" condition.

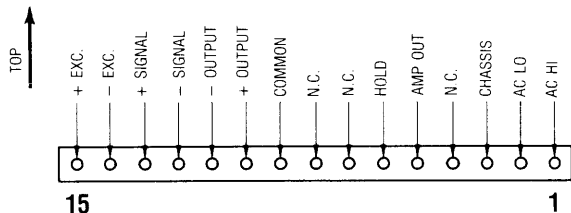

Rear Panel with Track & Hold Option



### 3.8 Power Connections

AC power is connected to the unit on terminals 1, 2 and 3. Observe that the AC LO terminal (#2) is connected to the AC power line neutral (white wire). The AC HI terminal (#1) connects to the "hot" side of the AC power (black wire). Terminal #3 is chassis ground (green wire). 110 volts, 60 Hz. is the normal power for the Model GM, but 220 volts, 50 Hz. may be provided through jumpering on the Main Board. Contact SENSOTEC for instructions on this modification.

### 4.0 Initial Adjustments/Setup

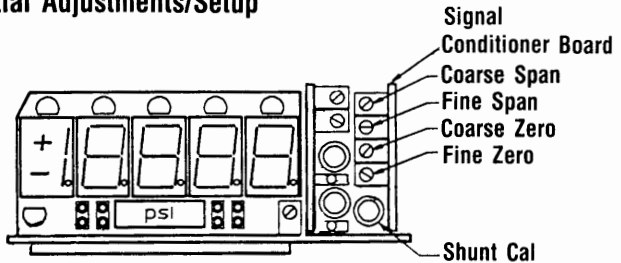

Figure 1—GM Control Locations

#### 4.1 Zero Adjustment

The adjustment of the no-signal zero indication is made first. For all of the adjustments that follow, the transducer attached to the unit should not have any applied pressure or load. If the transducer is an absolute pressure unit, it should be calibrated under a vacuum. Otherwise, the unit will read the present local barometric pressure (approx. 14.7 psi) and adjustment cannot be made using the ZERO adjustment only.

1. Remove the bezel and front panel with a small screwdriver.
2. Apply power to the Model GM. About 10 minutes warmup is sufficient.
3. Adjust the COARSE ZERO potentiometer (see figure 1) to give an output voltage on terminals 10 and 11 of about 0.V. Then adjust the FINE ZERO to bring this value to exactly 0.V.

#### 4.2 Span Adjustment

Span adjustment calibrates the gain of the amplifier section of the Signal Conditioner Board to provide the proper voltage output for a given pressure or load. The shunt calibration feature allows the span to be properly set-up without applying a known pressure or load to the transducer. This form of span adjustment will be described first, followed by a method for calibration when the shunt calibration value has not been determined.

##### 4.2.1 Span Adjustment with Shunt Calibration

A Transducer Calibration Record is normally shipped by all manufacturers of transducers with their products. (See example, Figure 2.) This record indicates the full scale output and the shunt calibration output of unamplified transducers in millivolts per volt (mv/v). These

two values are used to calculate the proper output of the Model GM under shunt calibration conditions. Calculate as follows:

$$\frac{\text{Shunt Cal Output in mv/v}}{\text{Full-Scale Output in mv/v}} \times \text{Full-Scale Output} = \text{Output Voltage}$$

<b>Transducer Calibration Record</b>		
<b>SENSOTEC, INC.</b>		
1200 Chesapeake Avenue	Columbus, Ohio	(614) 486-7723 TWX 810-482-1188
<b>LOAD CELL CALIBRATION RECORD</b>		
MODEL NO.: 4738-01		
SERIAL NO.: 156091		
FULL SCALE CAPACITY: 15000 LBS UNDER COMPRESSION		
DATE: 08/08/86		
EXCITATION VOLTAGE: 10 VDC CALIBRATION FACTOR 1.8888 MV/V AT FULL SCALE		
RESISTANCE:		
INPUT = 415 OHMS		
OUTPUT = 353 OHMS	LEAKAGE =	∞ OHMS
SHUNT RESISTOR VALUE OF 59K OHMS		
ACROSS NEGATIVE OF INPUT/OUTPUT GIVES 1.4883 MV/V		
ACCEPTED AND CERTIFIED BY _____		

**Figure 2**

Using the data in Figure 2 and the full-scale output of the Model GM (5V) provides:

$$\frac{1.4883 \text{ mv/v}}{1.8888 \text{ mv/v}} \times 5V = 3.939 \text{ volts}$$

After this calculation is made, proceed as follows:

1. Connect a meter to the output terminals (10, 11) on the rear connector.
2. Depress the SHUNT CALIBRATION button (See figure 1).
3. Adjust the COARSE SPAN control to give the **approximate** output voltage value calculated above.
4. Adjust the FINE SPAN control to give the **exact** output value calculated above.

After making these adjustments, a full scale pressure or load to the transducer will produce a 5-volt output from the Model GM.

**Note:** The Shunt Cal Output provided by the Transducer Calibration Record is determined using a particular value of Shunt Cal resistor. That value is also specified on the Transducer Calibration Record. It is necessary that the same value of resistor be installed to produce the same results. The normal value used by SENSOTEC for transducers is 59,000 ohms (59K). This value is installed in the pin jacks provided on the Signal Conditioner Board. If the transducer being used has a different value specified for its shunt cal resistor, it will be necessary to install this value in the jacks provided on the Signal Conditioner Board. A procedure for accomplishing this is given in the section entitled "Changing the Shunt Calibration Resistor."

## 4.2.2 Span Adjustment, Without Shunt Calibration

If the transducer shunt calibration output is not specified or not known, span can still be adjusted, but a known pressure or load must be applied to the transducer. The applied pressure should be as close to the full-scale value as possible, so that tiny errors in slope are not amplified by the ratio of full-scale to calibration point values. Calculate the expected output of the Model GM as follows:

$$\frac{\text{Known Pressure or Load}}{\text{Full Scale Pressure or Load}} \times \text{Full Scale Output} = \text{Output Voltage}$$

Once this calculation is made, proceed as follows:

1. Connect a meter to the output terminals (10, 11) on the rear connector.
2. Apply the known pressure or load to the transducer.
3. Adjust the COARSE SPAN control to give the approximate output voltage value calculated above.
4. Adjust the FINE SPAN control to give the exact output value calculated above.

## 4.3 Scaling Adjustment

Scaling adjustment permits the Model GM to display values in the engineering units desired by the customer. Adjustment can be made either with shunt calibration or with a known pressure or load on the transducer. Perform the scaling adjustment right after the span is adjusted, using the same output voltage to assist in calibration of scaling.

First, determine the desired full-scale value. For example, the load cell in Figure 2 is a 15,000 pound unit. The desired full-scale value would be 15,000 since a 4½ digit indicator is capable of indicating a maximum of 19,999 counts. Calculate the expected display value based on the voltage calculated in the span adjustment steps (4.2.1 or 4.2.2) as follows:

$$\frac{\text{Shunt Cal Output in mv/v}}{\text{Full Scale Output in mv/v}} \times \frac{\text{Full Scale Display Value}}{\text{Shunt Cal Display Value}}$$

Using the data in Figure 2 gives:

$$\frac{1.4883 \text{ mv/v}}{1.8888 \text{ mv/v}} \times 15,000 \text{ lbs.} = 11,819 \text{ lbs.}$$

After this calculation is made, proceed as follows:

1. Depress the SHUNT CALIBRATION button (see figure 3).

2. Adjust the SCALING potentiometer to yield the displayed value calculated above (11819 in the example).
3. Place the jumper in the proper place on the Display Board to locate the decimal point as illustrated in Figure 3.
4. Reinstall the front panel and bezel.

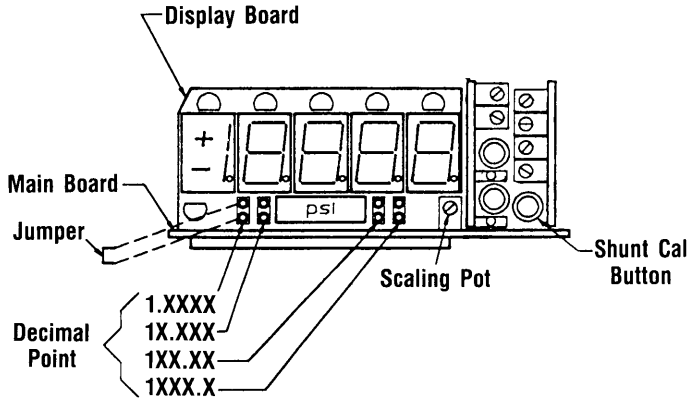

Figure 3—Decimal Points

## 5.0 Operative Adjustments

Operative adjustments are those adjustments that may be made from time to time in normal operation. These include “tweaking” the FINE ZERO and the FINE SPAN if these have moved, and setting the LIMITS potentiometers.

### 5.1 FINE ZERO Adjustment

Transducers usually have some small amount of zero drift, usually the result of temperature change at the transducer itself. With no pressure or load on the transducer, the zero may be readjusted to read zero by use of the front panel ZERO adjustment.

### 5.2 FINE SPAN Adjustment

After the FINE ZERO is readjusted, press the SHUNT CAL button to determine if the span is correct. If it needs adjustment, use the SPAN adjustment on the front panel.

## 6.0 Changing the Shunt Calibration Resistor

To change the Shunt Calibration Resistor, it is necessary to remove the Signal Conditioner Board from the Main Board. The steps involved are:

1. Unplug the AC power and remove the rear connector.
2. Remove the bezel and front panel (lens).

3. Carefully pull the Main Board out of the unit. All boards will come out simultaneously.
4. Gently remove the Signal Conditioner Board from the Main Board. (See figure 1.)
5. Remove the Shunt Calibration resistor from the Signal Conditioner Board (see figure 4), and replace it with the proper value.
6. Replace the Signal Conditioner Board onto the Main Board.
7. Slide the board assembly into the case.
8. Reinstall the front panel (lens) and bezel.
9. Reinstall the rear connector.

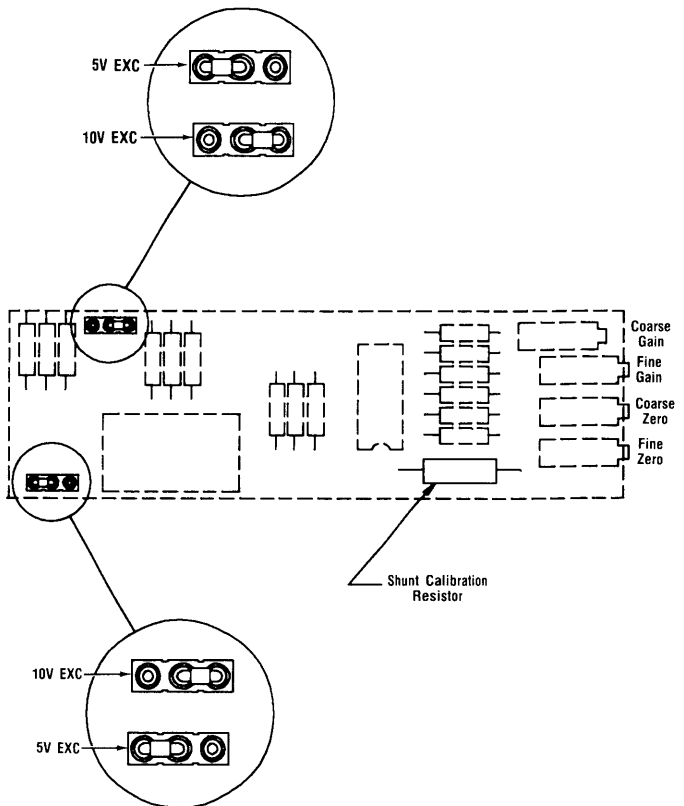

**Figure 4—GM Signal Conditioner Board**

## 7.0 Options

High/Low Limits, Peak Detection, or Track-and-Hold option cards are available as factory or field-installable options. Due to the small size of the Model GM, only one of these features can be installed in the same unit. To install an option card, proceed as follows:

1. Unplug the AC power and remove the bezel and front panel.
2. Carefully pull the Main Board out of the unit. All boards will come out simultaneously.
3. Remove the plug-in jumper from the otherwise empty socket parallel to the vertical Signal Conditioner Board. This jumper must be reinstalled on Pins 6 and 7 (counting from the front) if the unit is to be operated without an option card installed.
4. Install the option card on the Main Board and slide the board assembly into the case.
5. Install the new front panel associated with the option, and reinstall the bezel.

### 7.1 High/Low Limits Option

The Model GM Limits Option allows the transducer signal to be continuously compared to two adjustable set points called "limits." The high limit is L1; the low limit is L2. The Limits Option uses relay outputs, which are energized when the signal level exceeds the limit setting as illustrated in figure 5. LED indicators, located below the L1 and L2 pushbuttons, also light and are visible through the front cover when the limit is exceeded. (See Sec. 3.5 for relay wiring.)

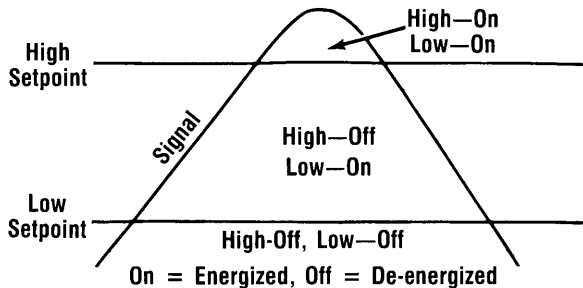

Figure 5—How Limits Work

#### 7.1.1 Setting the LIMITS Adjustments

Proceed to adjust as follows:

1. Unplug the AC power and remove the bezel and front panel with a small screwdriver.
2. Depress the desired LIMITS pushbutton (L1 or L2) to display the current setting of the limit detector.
3. Adjust the proper (L1 or L2) Limits potentiometer to give the desired limits value on the display.
4. Reinstall the front panel and bezel.

## 7.1.2 Limit Polarity and Hysteresis

If a limit de-energizes at the same level at which it is energized, a noisy input signal will cause the limit to oscillate, eventually destroying the relays. For this reason, the GM Limits Option contains "hysteresis," a 1% difference between the energizing point and the de-energizing point of the limit. This 1% difference should always be between the limit point and zero. For a positively set limit, the signal would rise, activating the limit. When the signal then drops, it must drop to 1% below the limit setting before the relay will de-energize. For negative setpoints, where the setting of the limit is a negative value, it is necessary to reverse the hysteresis polarity. (See figure 6.) At the factory, all limit hysteresis jumpers are set for a positive setpoint. If a negative setpoint is to be used, proceed as follows:

1. Unplug the AC power and remove the bezel, front panel, and Main Board.
2. Remove the Limits Option Board.
3. Locate the hysteresis jumper for the particular limit (either high or low). Place the jumper in the correct location to correspond to the limit setting for this limit.
4. Replace the Limits Option Board onto the Main Board.
5. Place the Main Board back into the case; reinstall the front panel and bezel.

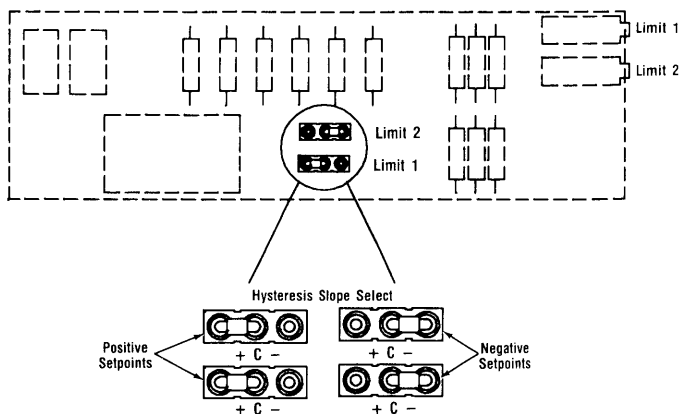

Figure 6—Hysteresis Jumpers On Limits Option Board

## 7.2 Peak Detector Option

The Model GM Peak Detector Option detects the highest positive value which has been attained by the signal since the peak detector was last reset. Reset may be accomplished by pressing the RST button on the front panel, or by interconnecting the RESET and COMMON terminals momentarily on the rear connector. Further, the PEAK OUT terminal will constantly monitor the peak detector output signal; the AMP OUT terminal and the display will monitor the amplifier out-

put normally, but will shift to monitor the output of the peak detector when one of two conditions occurs:

1. The front panel PK button is pressed upward (momentary) or downward (locking).
2. The MODE SEL and COMMON terminals on the rear panel are interconnected.

### 7.3 Track-and-Hold Option

The Model GM Track-and-Hold Option permits the GM to stop tracking an input signal upon command. This command can be issued by completing a contact closure remotely, or by front panel pushbutton. When the Track-and-Hold feature is in the "hold" mode, the front-panel HOLD light will be lighted. The HOLD button on the front panel works alternately, so that one push will activate the hold feature, and the next push will deactivate it. Potentiometers on the Track-and-Hold board permit small errors of zero and span to be tuned out, so that true tracking results.

If it is desired that the "hold" feature be activated by rear panel means, connection of the HOLD terminal with the COMMON terminal will cause the unit to go into HOLD mode. The OUTPUT signal terminals (rear connector) will track the input signal unless the HOLD mode is active. The AMP OUT terminal will always track the input signal regardless of the condition of the HOLD signal.

## 8.0 Troubleshooting Guide

### Symptom/Problem

### Action/Troubleshooting

<b>Erratic Display</b>	Check electrical connections for continuity and wiring code for pin layout.
<b>No Display/No Output Voltage</b>	Check power connections per instrument instructions.
<b>Blinking Display</b>	Indicates a signal level greater than full scale; make sure wires are all connected, and transducer is within its range.
<b>Incorrect Readout Value</b>	Check transducer range on label. Verify that system was set-up per instructions. Review set-up procedure. Refer to transducer troubleshooting guide and verify that transducer operates properly. Use Shunt Cal to verify calibration.
<b>Limit 1 or 2 fails to trip relay at setpoint</b>	Verify that limit card is properly installed; check normally open, common, and normally closed contacts on rear-panel connector for proper wiring.
<b>Peak detector will not reset or will not hold peak value</b>	Verify that Peak Detector Card is properly installed; check Mode Sel and common terminal on rear-panel connector for proper wiring.
<b>Track-and-Hold unit will not hold signal when front panel switch is pushed</b>	Verify that track-and-hold card is properly installed; check Hold and Common terminals on rear-panel for proper wiring. Verify that the HOLD light is coming on in the hold mold.



## **9.0 Drawings**

Customers desiring to repair failed boards themselves can request appropriate drawings from SENSOTEC, at a nominal charge. Note that any attempt to repair the unit by anyone other than SENSOTEC's Repair Department voids the product warranty.

## **10.0 Warranty Repair Policy**

### **10.1 Limited Warranty on Products**

Any of our products which, under normal operating conditions, proves defective in material or in workmanship within one year from the date of shipment by SENSOTEC, will be repaired or replaced free of charge provided that you obtain a return material authorization from SENSOTEC and send the defective product, transportation charges prepaid with notice of the defect, and establish that the product has been properly installed, maintained, and operated within the limits of rated and normal usage. Replacement or repaired product will be shipped F.O.B. our plant. The terms of this warranty do not extend to any product or part thereof which, under normal usage, has an inherently shorter useful life than one year. The replacement warranty detailed here is the buyer's exclusive remedy, and will satisfy all obligations of SENSOTEC whether based on contract, negligence, or otherwise. SENSOTEC is not responsible for any incidental or consequential loss or damage which might result from a failure of any SENSOTEC product. This express warranty is made in lieu of any and all other warranties, express or implied, including implied warranty of merchantability or fitness for particular purpose. Any unauthorized disassembly or attempt to repair voids this warranty.

### **10.2 Obtaining Service Under Warranty**

Advance authorization is required prior to the return to SENSOTEC. Before returning the items, either write to the Repair Department c/o SENSOTEC, Inc., 1200 Chesapeake Avenue, Columbus, Ohio 43212, or call (614) 486-7723 with: 1) a part number; 2) a serial number for the defective product; 3) a technical description\* of the defect; 4) a no-charge purchase order number (so products can be returned to you correctly); and 5) ship and bill addresses. Shipment to SENSOTEC shall be at Buyer's expense and repaired or replacement items will be shipped F.O.B. our plant in Columbus, Ohio. Non-verified problems or defects may be subject to a \$75 evaluation charge. Please return the original calibration data with the unit.

### **10.3 Obtaining Non-Warranty Service**

Advance authorization is required prior to the return to SENSOTEC. Before returning the item either write to the Repair Department c/o SENSOTEC, Inc., 1200 Chesapeake Avenue, Columbus, Ohio 43212, or call (614) 486-7723 with: 1) a model number; 2) a serial number for the defective product; 3) a technical description\* of the malfunction; 4) a purchase order number to cover SENSOTEC's repair cost;

and 5) ship and bill addresses. After the product is evaluated by SENSOTEC, we will contact you to provide the estimated repair costs before proceeding. The minimum evaluation charge is \$75. Shipment to SENSOTEC shall be at Buyer's expense and repaired items will be shipped to you F.O.B., our plant in Columbus, Ohio. Please return the original calibration data with the unit.

#### **10.4 Repair Warranty**

All repairs of SENSOTEC products are warranted for a period of 90 days from date of shipment. This warranty applies only to those items which were found defective and repaired, it does not apply to products in which no defect was found and returned as is or merely recalibrated. Out of warranty products may not be capable of being returned to the exact original specifications or dimensions.

\*Technical description of the defect: In order to properly repair a product, it is absolutely necessary for SENSOTEC to receive information specifying the reason the product is being returned. Specific test data, written observations on the failure and the specific corrective action you require are needed.

#### **11.0 Glossary of Signal Conditioning Terms**

**ACCURACY**—The combined error of nonlinearity, repeatability, and hysteresis expressed as a percent of full-scale output.

**CHARACTERS DISPLAYED**—The number of digits in a display. Some of the digits may be active (part of the quantizing process), and some may be passive (displaying a constant zero).

**COMMON-MODE REJECTION**—The ability of an instrument to reject the effects of signals such as noise, that appear on all signal lines. Expressed as a logarithmic decibel ratio at a particular maximum voltage.

**CONVERSIONS PER SECOND**—The number of times per second that an analog-to-digital converter ranges and quantizes a given input.

**COUNTS**—The total number of steps of resolution of an instrument.

**dB (DECIBEL)**—20 times the log to the base 10 of the ratio of two numbers.

**DIN (DEUTSCHE INDUSTRIE NORM)**—A set of German standards, now being recognized throughout the world. A 1/8 DIN standard specifies an outer bezel dimension of 96 mm (3.78") x 48 mm (1.89"), and a panel cutout of 92 mm (3.62") x 45 mm (1.77").

**EXCITATION**—The voltage applied to the strain-gage transducer by the signal conditioning device.

**FREQUENCY RESPONSE**—The range of frequencies over which the transducer voltage output will follow the sinusoidally-varying stimulus input within the specified accuracy of the instrument.

**FULL-SCALE OUTPUT**—The maximum output derived from the signal conditioner when the transducer is at its full scale value. For example, a 100 psi pressure applied to a 100 psi transducer will

cause a full-scale output from the signal conditioner. Full-scale output is usually 5 volts.

**GAIN RANGE**—The range of signal multiplication factors for a given signal conditioner.

**INPUT IMPEDANCE**—The resistance of the input circuit of a signal conditioner. If this value is large, the signal conditioner will not load the transducer output excessively.

**LINEARITY**—The maximum deviation of a calibration curve from a straight line connecting zero with the full-scale value, expressed as a percent of the full-scale value.

**LSD (LEAST SIGNIFICANT DIGIT)**—The rightmost active digit in a display.

**MSD (MOST SIGNIFICANT DIGIT)**—The leftmost digit in a display.

**NOISE AND RIPPLE**—Noise is randomly-occurring low-level signal not related to the stimulus. Ripple is periodic noise, usually associated with the signal conditioner power supply. Both noise and ripple limit the ability of a signal conditioner to handle small signals.

**RESOLUTION**—The smallest change in input signal which produces a one-digit change in the display.

**SHUNT-CAL**—The change in electrical output of a transducer which is caused by momentarily placing a fixed, known resistance between one leg of a strain gage transducer and one of the excitation leads. This causes the bridge to become unbalanced by a precise, known amount, and permits the verification of proper gain in the signal conditioning system.

**SIGNAL CONDITIONER**—An instrument which provides precise electrical drive to a transducer, and accepts and amplifies the transducer output. It may also digitize and display the output in engineering units.

**SPAN ADJUSTMENT**—The ability to adjust the gain of a signal conditioner so that a specified display span in engineering units corresponds to a specified signal span.

**ZERO ADJUSTMENT**—The adjustment of the displayed value to zero when no output signal is being issued by the transducer.



# SENSOTEC

SENSOTEC, INCORPORATED  
2080 Arlingate Lane Columbus, Ohio 43228  
(614) 850-6000 TWX 810-482-1188

