

Installation Instructions for the RTY Series Hall-Effect Rotary Position Sensor

GENERAL INFORMATION

The RTY Series uses a magnetically biased, Hall-effect integrated circuit (IC) to sense rotary movement of the actuator shaft over a set operating range. Rotation of the actuator shaft changes a magnet's position relative to the IC. The resulting flux density change is converted to a linear output.

MOUNTING INFORMATION

Mount the sensor and/or lever using flat washers and screws as shown in Figures 1 and 2.

In harsh applications, treat the screw threads with a suitable thread locking compound.

Table 1. Specifications

Characteristic	Parameter	
	LV (Low Voltage)	HV (High Voltage)
Supply voltage	5 ±0.5 Vdc	10 Vdc to 30 Vdc
Supply current	20 mA max.	32 mA max.
Supply current (during output to ground short)	25 mA max.	47 mA max.
Output: standard inverted ²	0.5 Vdc to 4.5 Vdc ratiometric 4.5 Vdc to 0.5 Vdc ratiometric	0.5 Vdc to 4.5 Vdc non-ratiometric 4.5 Vdc to 0.5 Vdc non-ratiometric
Output signal delay	4 ms typ.	
Overvoltage protection	10 Vdc	-
Reverse polarity protection	-10 Vdc	-30 Vdc
Output to ground short circuit protection	continuous	
Output load resistance (pull down to ground)	10 kOhm typ.	
EMI: radiated immunity conducted immunity	100 mV per ISO11452-2 from 200 MHz to 1000 MHz 100 mA BCI per ISO11452-4 from 1 MHz to 200 MHz	100 mV per ISO11452-2 from 200 MHz to 1000 MHz 100 mA BCI per ISO11452-4 from 1 MHz to 400 MHz
EMC	exceeds CE requirements	
Operating temp. range	-40 °C to 125 °C [-40 °F to 257 °F]	
Storage temperature range	-40 °C to 125 °C [-40 °F to 257 °F]	
Ingress protection	IP67 according to DIN 40050	
Expected life	35 M cycles	
Media compatibility	heavy transportation fluids	
Housing material	PBT plastic	
Shock ¹	50 G peak	
Vibration ¹	20 G peak tested from 10 Hz to 2000 Hz	
Salt fog	concentration 5% ±1% for 240 hr per SAE M1455 Section 4.3.3.1 (at 5.0 Vdc, 38 °C [100 F °])	
Resolution	12 bit	
Mating connector	AMP Superseal 282087-1	
Mechanical end stop	no	
Approvals	CE	

¹ Applies to RTY sensor without lever only.

² Removes the requirement for the customer to have to invert the logic associated with the application. This is a convenience for the customer, and in some cases, can simplify the customer's overall solution.

RTY Series Hall-Effect Rotary Position Sensor

ISSUE 4
50069443

Table 2. Output

Standard Output	Inverted Output
(A) = Left output: 0.5 Vdc	(A) = Left output: 4.5 Vdc
(B) = Zero reference	(B) = Zero reference
(C) = Right output: 4.5 Vdc	(C) = Right output: 0.5 Vdc

Table 3. Pinout

North American	European
Pin 1 = Vcc	Pin 1 = GND
Pin 2 = GND	Pin 2 = Vcc
Pin 3 = Output	Pin 3 = Output



NOTICE
Ferrous material or more than 300 Gauss magnet within a 10 mm [0.39 in] radius of sensor may affect sensor performance.

Table 4. Functional Characteristics

Sensing Angle	Linearity Error	Accuracy Error	Standard Input	Inverted Input
50° (±25°)	±1.0%	±1.6%	<p>Output Voltage (Vdc)</p> <p>Clamp High 4.5</p> <p>Clamp Low 0.0</p> <p>(A) (B) (C)</p> <p>-25 0 +25 -30 0 +30 -35 0 +35 -45 0 +45 -60 0 +60 -90 0 +90 -135 0 +135</p> <p>Actuator Position (°)</p>	<p>Output Voltage (Vdc)</p> <p>Clamp High 4.5</p> <p>Clamp Low 0.0</p> <p>(A) (B) (C)</p> <p>-25 0 +25 -30 0 +30 -35 0 +35 -45 0 +45 -60 0 +60 -90 0 +90 -135 0 +135</p> <p>Actuator Position (°)</p>
60° (±35°)				
70° (±35°)				
90° (±45°)				
120° (±60°)				
180° (±90°)				
270° (±135°)				
360° (±180°)	<p>Output Voltage (Vdc)</p> <p>(A) (B) (C)</p> <p>-180 0 +180</p> <p>Actuator Position (°)</p>	<p>Output Voltage (Vdc)</p> <p>(A) (B) (C)</p> <p>-180 0 +180</p> <p>Actuator Position (°)</p>		

• See table 2 for A, B, C references.

• The linearity error is the deviation of the measured value from the best fit line and is the quotient of the measured output ratio deviation from the best fit line at the measured temperature to the best fit line output ratio span at the measured temperature.

• Accuracy is measured as a deviation from the index line, where the index line is defined as the line with the ideal slope and sensor output voltage corrected at 0° position for its ideal value at 25 °C ±5 °C. Accuracy is valid only when the sensor output is correct at 0° position for its ideal value in the application.

RTY Series Hall-Effect Rotary Position Sensor

ISSUE 4

50069443

Figure 1. Dimensional Drawings for Sensor with Lever (For reference only: mm [in])

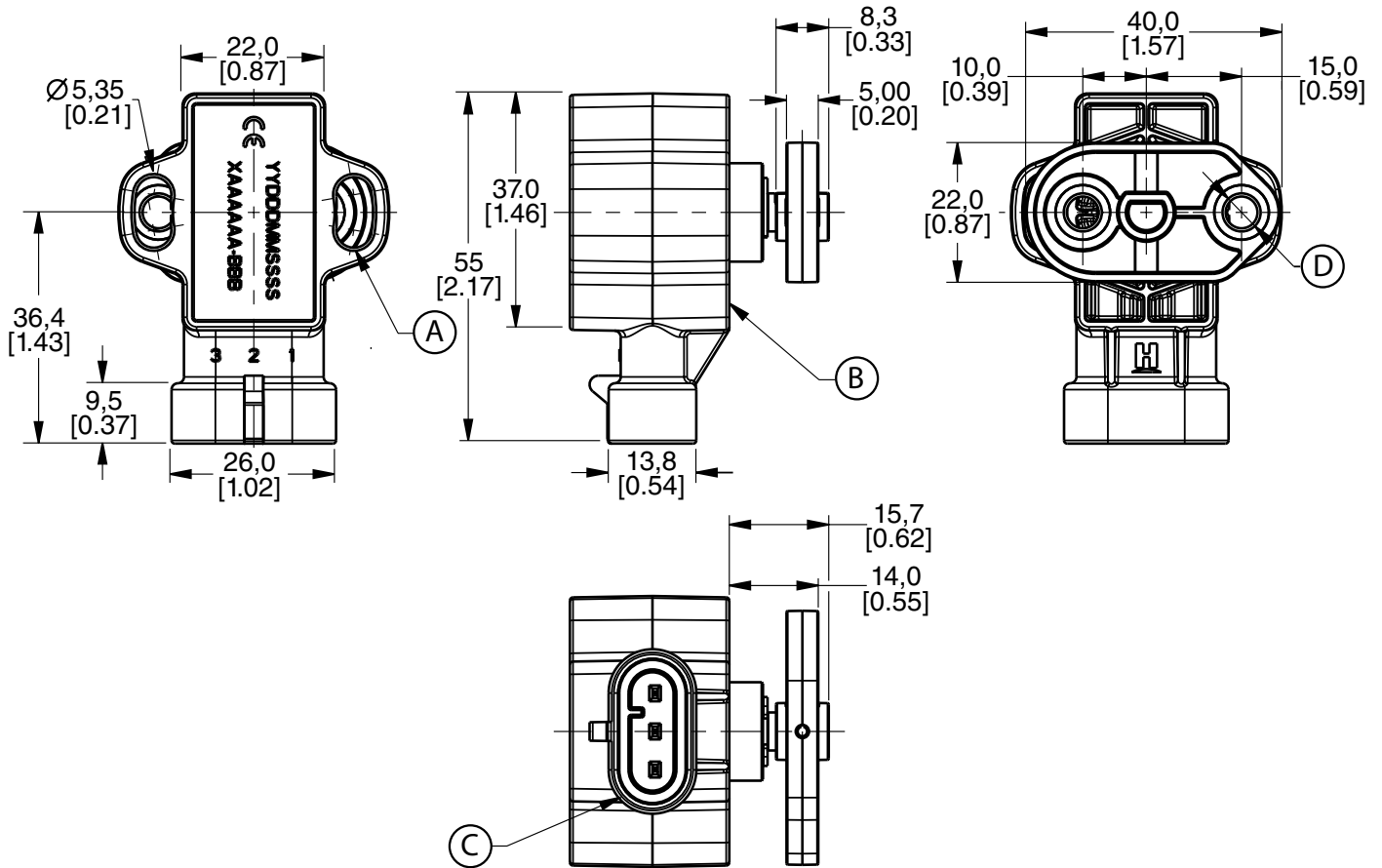

- (A) Mount sensor with non-magnetic stainless steel M5 screws. Mounting torque is $2,5 \pm 0,5$ N m [22.1 \pm 4.4 in-lb].
- (B) Mounting surface.
- (C) Mating connector: AMP superseal 282087-1.
- (D) Mount lever using M6x1 screws. Mounting torque 8 N m [70.8 in-lb] max.

RTY Series Hall-Effect Rotary Position Sensor

ISSUE 4
50069443

Figure 2. Dimensional Drawings for Sensor without Lever (For reference only: mm [in])

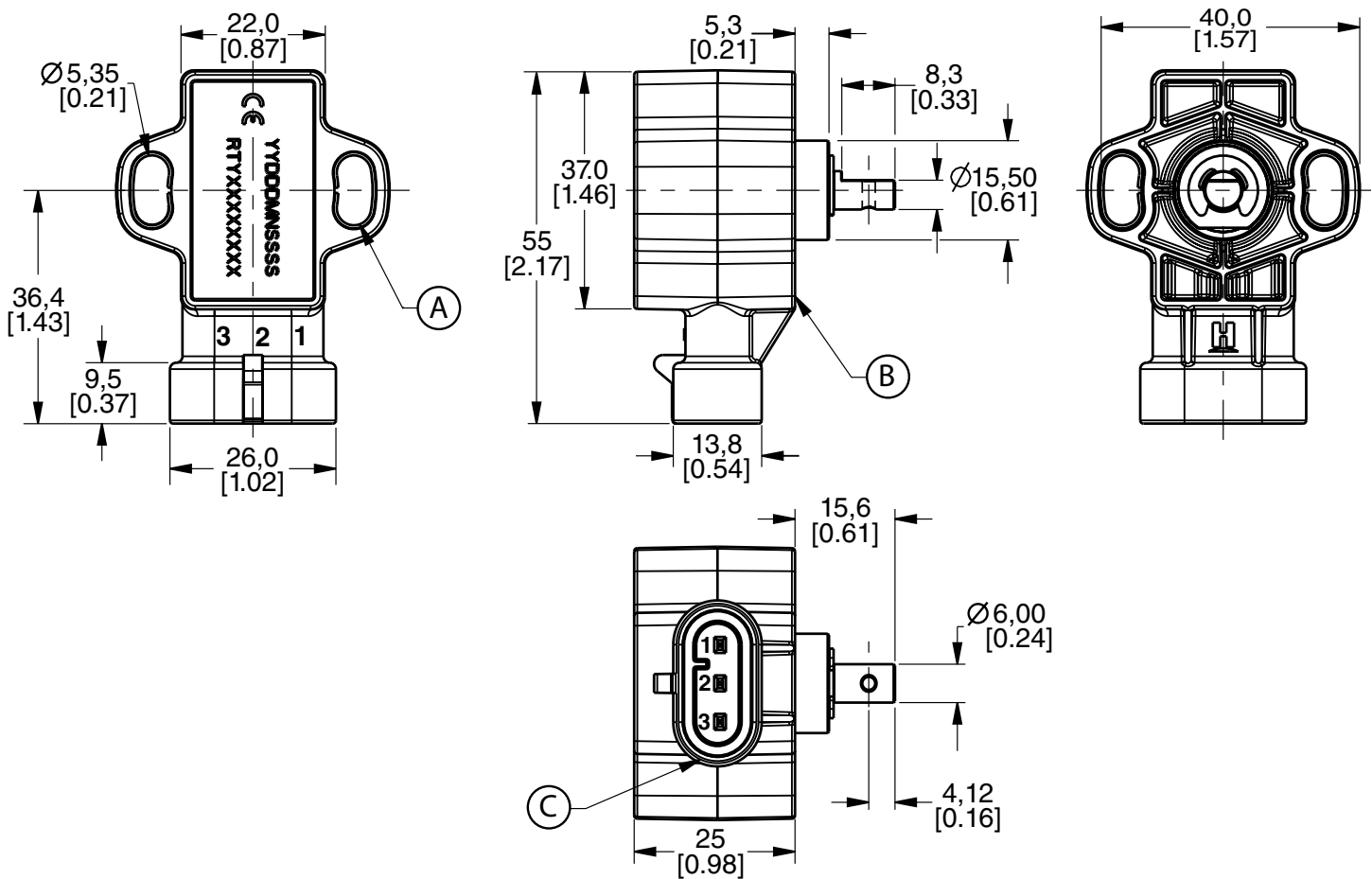

- (A) Mount sensor with non-magnetic stainless steel M5 screws. Mounting torque is 2.5 ± 0.5 N m [22.1 ± 4.4 in-lb].
- (B) Mounting surface.
- (C) Mating connector: AMP superseal 282087-1.

RTY Series Hall-Effect Rotary Position Sensor

ISSUE 4

50069443

WARNING

PERSONAL INJURY

DO NOT USE these products as safety or emergency stop devices or in any other application where failure of the product could result in personal injury.

Failure to comply with these instructions could result in death or serious injury.

WARRANTY

Honeywell warrants goods of its manufacture as being free of defective materials and faulty workmanship. Honeywell's standard product warranty applies unless agreed to otherwise by Honeywell in writing; please refer to your order acknowledgement or consult your local sales office for specific warranty details. If warranted goods are returned to Honeywell during the period of coverage, Honeywell will repair or replace, at its option, without charge those items it finds defective. **The foregoing is buyer's sole remedy and is in lieu of all warranties, expressed or implied, including those of merchantability and fitness for a particular purpose. In no event shall Honeywell be liable for consequential, special, or indirect damages.**

While we provide application assistance personally, through our literature and the Honeywell web site, it is up to the customer to determine the suitability of the product in the application.

Specifications may change without notice. The information we supply is believed to be accurate and reliable as of this printing. However, we assume no responsibility for its use.

SALES AND SERVICE

Honeywell serves its customers through a worldwide network of sales offices, representatives and distributors. For application assistance, current specifications, pricing or name of the nearest Authorized Distributor, contact your local sales office or:

E-mail: info.sc@honeywell.com

Internet: sensing.honeywell.com

Phone and Fax:

Asia Pacific	+65 6355-2828
	+65 6445-3033 Fax
Europe	+44 (0) 1698 481481
	+44 (0) 1698 481676 Fax
Latin America	+1-305-805-8188
	+1-305-883-8257 Fax
USA/Canada	+1-800-537-6945
	+1-815-235-6847
	+1-815-235-6545 Fax

Honeywell Sensing and Control

1985 Douglas Drive North
Golden Valley, MN 55422
sensing.honeywell.com

50069443-4-EN
October 2013
© 2013 Honeywell International Inc. All rights reserved.

Honeywell