

## Technical Note

# Output Signal Adjustment and Temperature Compensation for Honeywell Basic Board Mount Pressure Sensors: TBP Series—Compensated/Unamplified NBP Series—Uncompensated/Unamplified

### 1.0 INTRODUCTION

Honeywell offers a broad range of board mount pressure sensors including fully amplified and compensated, compensated, and uncompensated sensors.

- **Amplified and compensated:** These sensors are usually used as is (plug and play) without the need for additional modification by the customer. Examples are Honeywell's TruStability® HSC Series and SSC Series.
- **Compensated:** These sensors provide part-to-part inter changeability, calibration, and temperature compensation. An example is Honeywell's TBP Series. Compensated sensors, however, may require the use of amplification circuitry, assuming that an ASIC (Application-Specific Integrated Circuit) with a mV input ADC (Analog to Digital Converter) is not being used. Examples of useful amplification circuitry that can be used with the TBP series can be found in Section 4.0.
- **Uncompensated:** These sensors provide raw sensor output and are not compensated in any way. An example is Honey well's NBP Series. They usually require some form of compensation to be able to be used in many applications.

This Technical Note describes several compensation techniques for use with the TBP and NBP Series (Figure 1). Pinouts shown are for the DIP and Leaded SMT devices. See the published datasheets for the TBP and NBP Series Basic Board Mount Pressure Sensors for the Leadless SMT pinout.

**Figure 1. Basic Board Mount Pressure Sensors: TBP and NBP Series**



### 2.0 OUTPUT SIGNAL ADJUSTMENT: SETTING NULL OFFSET TO ZERO (NBP SERIES)

The NBP Series—Uncompensated/Unamplified has a wide tolerance on null offset and span and do not include temperature compensation. The following procedures can be used to set the null offset and span to the desired output values and to compensate for temperature shift.

1. Measure null offset (lead 4 to 2).
2. For a negative null offset place a resistor from lead 1 (supply) to lead 4 (positive output). Expect values around 300 kOhm (Figure 2).
3. For a positive null offset, place a resistor from lead 1 (supply) to lead 2 (negative output). Expect values around 300 kOhm (Figure 3).

**Figure 2. Negative Null Offset Circuit**

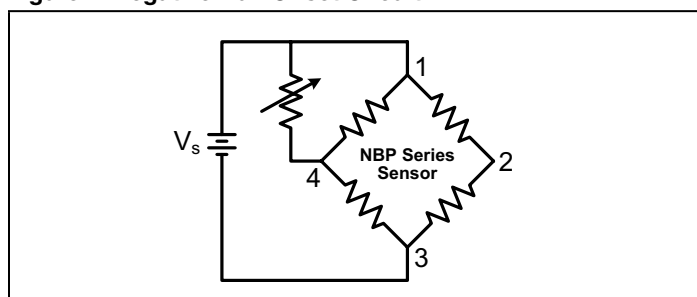

**Figure 3. Positive Null Offset Circuit**

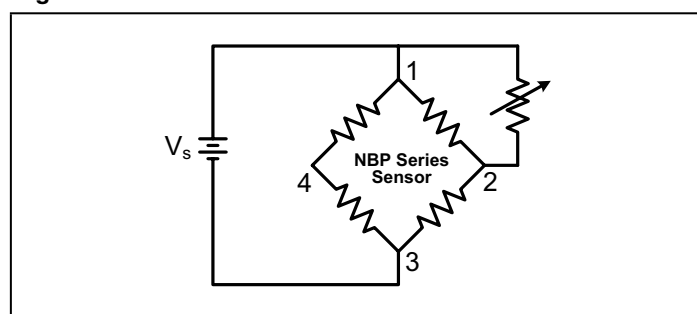

# Technical Note

## Output Signal Adjustment and Temperature Compensation for Honeywell Basic Board Mount Pressure Sensors: TBP Series, Compensated/Unamplified NBP Series, Uncompensated/Unamplified

### 3.0 ENSURING NULL OFFSET IS ALWAYS POSITIVE (TBP AND NBP SERIES)

Sometimes the need arises to ensure that the sensor will respond to increasing positive pressure (monotonically), whether connected to an op-amp (operational amplifier), instrumentation amplifier, or an input to an ADC.

If the null offset from the sensor is not corrected, a negative null offset could drive the instrumentation to the ground rail until the input pressure is enough to counteract this effect. If this occurs, it means that the sensor will not give a pressure readout in the lower pressure ranges.

In order to avoid this, the worst case null offset along with the null offset temperature drift needs to also be taken into account. The worst case null of -7 mV/Vdc and the null tempco specification of -1.5 %FSS per 25 °C for the NBP Series provides the worst case scenario and ensures that the sensor output will always be positive regardless of the specific NBP Series catalog listing. This translates to a total null offset error of approximately -35 mV and -3 mV (-38 mV) when using a 5 Vdc supply.

Setting the offset so that it is always positive can be accomplished by placing a resistor between Pins 1 (supply) and Pin 4 (positive output) as shown in Figure 4. The worst-case value needed to do this is 95.3 kOhm based on the above conditions. This is a worst-case value for all of the NBP Series; therefore, in some cases, this might actually drive the offset positive by as much as 80 mV.

Figure 4. Always Positive Null Offset Circuit

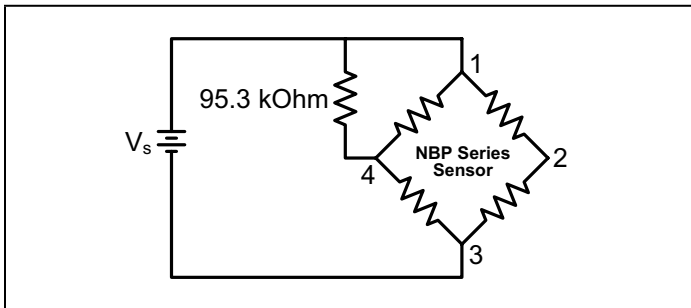

### 4.0 TEMPERATURE COMPENSATION (NBP SERIES)

Uncompensated pressure sensors exhibit sensitivity decreases with an increase in temperature. The resistive elements increase in value with an increase in temperature and this adds to the temperature error. As the resistance in the Wheatstone bridge increases, the current through the resistors decreases, furthering the error due to the inherent decrease in sensitivity in the pressure sensor. To counter the effect of the resistance change over temperature, a constant current source excitation instead of voltage excitation maybe used to reduce the temperature error.

There are a number of ways of generating a constant current for the current excitation. Figures 5 and 6 show several methods of supplying a 1.5 mA of constant current to the device.

#### Constant Current Using an Op-Amp

Figure 5 shows a common configuration using an LM2902 or LM358 op-amp.

Figure 5. Constant Current Circuit Using an Op-Amp

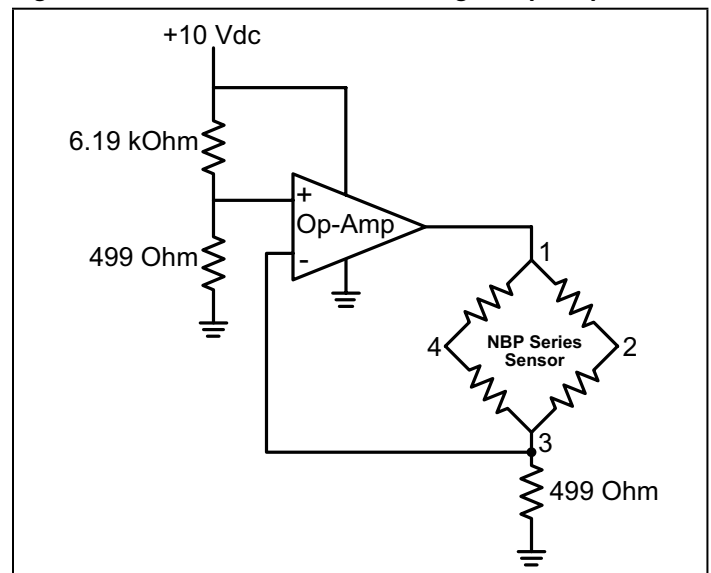

# Technical Note

## Output Signal Adjustment and Temperature Compensation for Honeywell Basic Board Mount Pressure Sensors: TBP Series, Compensated/Unamplified NBP Series, Uncompensated/Unamplified

### Constant Current Using a Constant Current Source and a Resistor

Figure 6 shows a configuration using an LM334 constant current source from Linear Technology, with one resistor set to the current output.

**Figure 6. Constant Current Circuit Using a Constant Current Source and a Resistor**

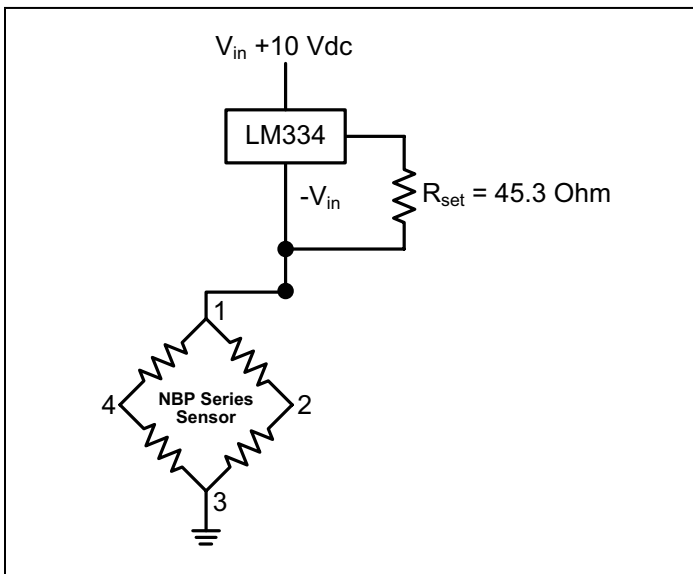

### 4.0 AMPLIFICATION CIRCUIT EXAMPLES (TBP AND NBP SERIES)

There are numerous methods for amplifying the raw output from a Wheatstone bridge sensor. Two examples are shown in Figures 7 and 8.

#### Amplification Using a Discrete Op-Amp (Figure 7)

This method uses a discrete op-amp such as the LM2902 or LT1014. This allows the user to change the null offset as well as the gain. The null offset should be adjusted using one of the procedures in Section 2.0 prior to using this circuit.

The equation for this circuit is:

$$((2 R_2/R_1) + 1) \times (R_4/R_3) + V_{offset}$$

$$V_{offset} = V_s \times (R_6/R_5 + R_6)$$

Let:

- R1 = 20 kOhm potentiometer
- R2 = 100 kOhm
- R3 = 100 kOhm    R4 = 200 kOhm
- R5 = 100 kOhm
- R6 = 50 kOhm potentiometer

The supply voltage to the op-amp needs to be 8 Vdc minimum because the maximum output from the LM2902 is  $V_s - 1.5$  Vdc. The supply to the voltage divider and the NBP Series sensor can be another regulated voltage, i.e., 3.3 Vdc or 5 Vdc. If this is done, then the grounds to the supplies need to be connected (commoned) together.

**Figure 7. Amplification Circuit using a Discrete Op-Amp**

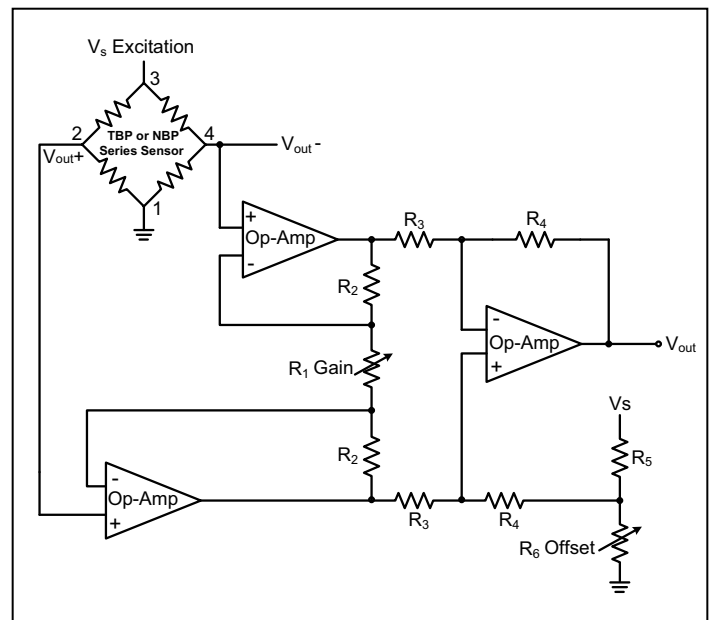

# Technical Note

## Output Signal Adjustment and Temperature Compensation for Honeywell Basic Board Mount Pressure Sensors: TBP Series, Compensated/Unamplified NBP Series, Uncompensated/Unamplified

### Amplification Using an Instrumentation Amplifier (Figure 8.)

There are manufacturers who provide complete instrumentation amplifiers, such as the AD623, that only require a few resistors to set the offset and span.

The gain is adjusted by selecting the value of  $R_g$ :  
 $R_g = 100000 / (\text{gain} - 1)$ .

As an example, for a gain of 40, the value of  $R_g$  would be 2564 Ohm. The offset adjustment is made by changing the reference voltage, which can be accomplished using two resistors as a voltage divider.

Figure 8. Amplification Circuit Using an Instrumentation Amplifier

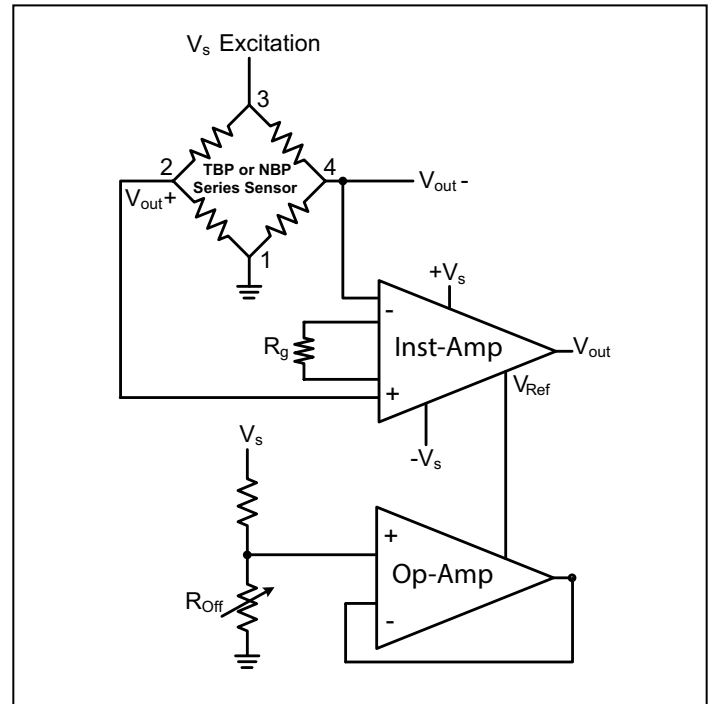

### Find out more

To learn more about Honeywell's sensing and control products, call **1-800-537-6945**, visit **sensing.honeywell.com**, or e-mail inquiries to **info.sc@honeywell.com**

Sensing and Control  
Honeywell  
1985 Douglas Drive North  
Golden Valley, MN 55422  
**honeywell.com**

**Warranty.** Honeywell warrants goods of its manufacture as being free of defective materials and faulty workmanship. Honeywell's standard product warranty applies unless agreed to otherwise by Honeywell in writing; please refer to your order acknowledgement or consult your local sales office for specific warranty details. If warranted goods are returned to Honeywell during the period of coverage, Honeywell will repair or replace, at its option, without charge those items it finds defective. **The foregoing is buyer's sole remedy and is in lieu of all warranties, expressed or implied, including those of merchantability and fitness for a particular purpose. In no event shall Honeywell be liable for consequential, special, or indirect damages.**

While we provide application assistance personally, through our literature and the Honeywell web site, it is up to the customer to determine the suitability of the product in the application.

Specifications may change without notice. The information we supply is believed to be accurate and reliable as of this printing. However, we assume no responsibility for its use.

**Honeywell**