



# **CF4680 2D Imager Module**

---

**For Customer-Facing Designs**

## **Quick Start Guide**

## What is the CF4680 2D Imager Module?

The CF4680 is a 2D imager module designed to be integrated into fixed mount enclosures, such as a self-service kiosk. It includes:

- N4680 scan engine
- USB interface (USB-B connector)
- Exit window
- Movement detector used to start a reading session
- User feedback pins

## Required Accessories

- Standard USB-A to USB-B cable

## Additional Documentation

The following documents are available for the CF4680:

- *CF4680 Installation Guide*
- *N4680/CF4680 User Guide*

These documents are available from your local Honeywell OEM representative.

## CF4680 Front View

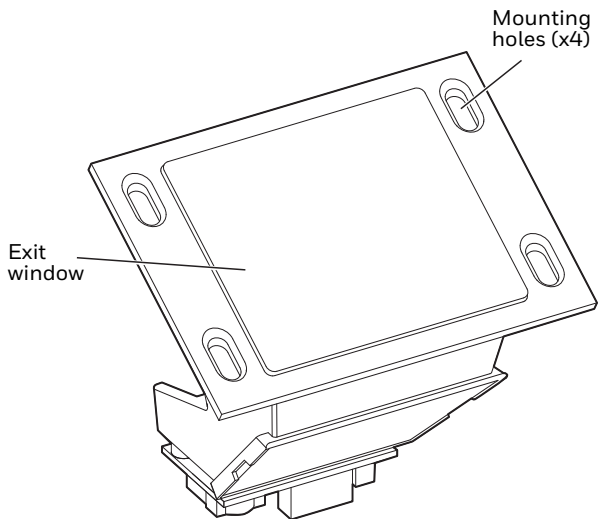

## CF4680 Back View

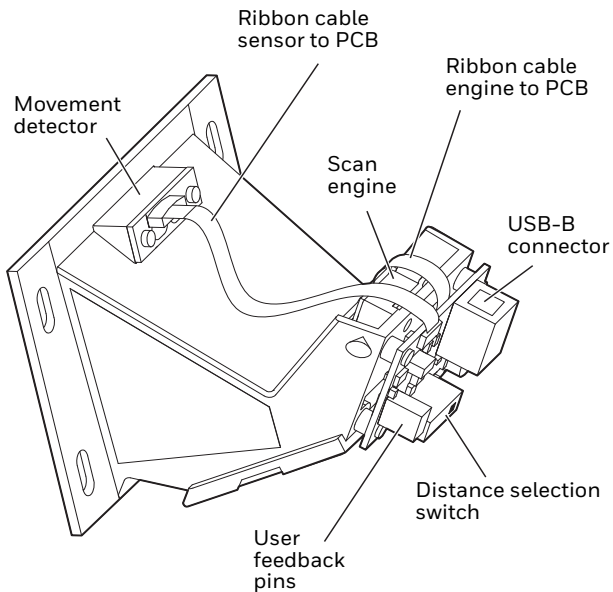

# PCB View

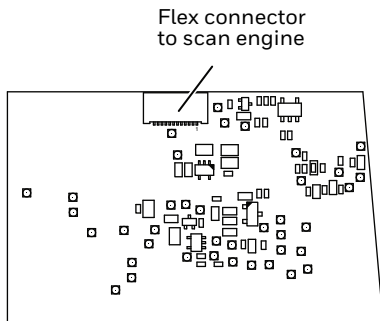
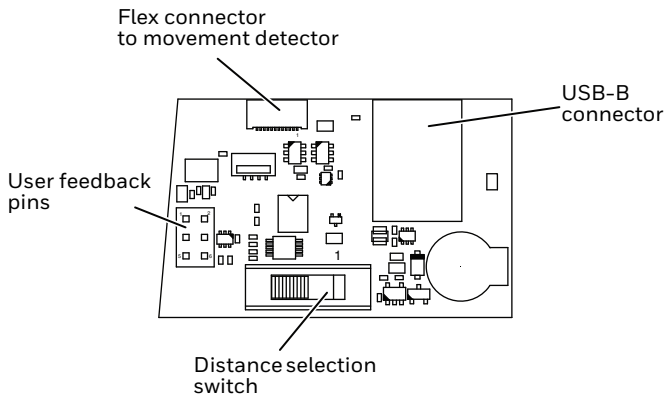

## Connecting the CF4680 to a Host

By default, the CF4680 is in USB PC Keyboard interface.

1. Connect a standard USB cable (standard USB-A to USB-B) to the CF4680 and to the USB port on the host.
2. Power-up the host.
3. Verify that the CF4680 is on by presenting a bar code in front of the scan window. The white LED should turn on and read the bar code.

**Note:** *The CF4680 does not beep to indicate a good read unless this has been setup by the user with the user feedback pins. See the CF4680 Installation Guide for more details (available from your local Honeywell OEM representative).*

## Distance Selection Switch

Use this switch to select the range to be used to detect an object and trigger the scan engine. The distance is measured from the outside of the exit window.

- Position 1—0 to 10 cm (4 in)
- Position 2—0 to 20 cm (8 in)
- Position 3—0 to 30 cm (12 in)

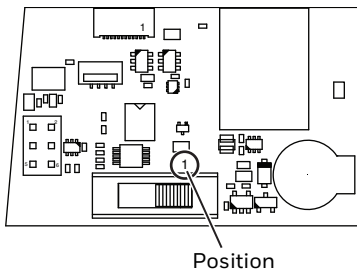

## Configuration

You can configure your scanner two ways:

- Reading configuration bar codes
- Using the EZConfig Cloud for Scanning tool

### Configuration Bar Codes

Scan configuration bar codes to set up your scanner. All available configuration bar codes are available in the *N4680/CF4680 User Guide*. Contact your local Honeywell OEM representative for more information.

### EZConfig for Scanning Tool

Use the EZConfig for Scanning tool to configure your scanner Online:

1. Go to the Honeywell <https://hsmftp.honeywell.com>.
2. Register (if you haven't already), then login.
3. Browse to **Software > Barcode Scanners > Software > Tools and Utilities > EZConfig for Scanning > Current** and download the tool.
4. Open EZConfig to configure your scanner.



## Basic Setup

Here are some basic menu bar codes that may be useful for testing. For more setup options see the *N4680/CF4680 User Guide* (available from your local Honeywell OEM representative).

**Note:** The \* symbol indicates the default value.

## Interface

For USB serial interface, you must install the USB driver before connecting your scanner. Contact your local Honeywell OEM representative to get the latest USB driver.

USB Serial Interface



TERMID130.

USB PC Keyboard \*



TERMID124.

## Keyboard Country Layout

The default keyboard is United States.

French



KBDCTY3.

German



KBDCTY4.

Italian



KBDCTY5.

## All Symbologies

All Symbologies On



ALLENA1.

All Symbologies Off



ALLENA0.

## LED Illumination

Use this setting to change the LED illumination brightness.

Low \*



PWRNOL100.

Medium



PWRNOL120.

High



PWRNOL150.

## Reset Factory Defaults

The following bar code resets factory defaults.



DEFAULT.

# Mechanical Dimensions

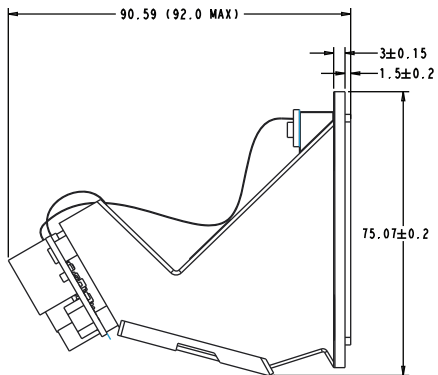

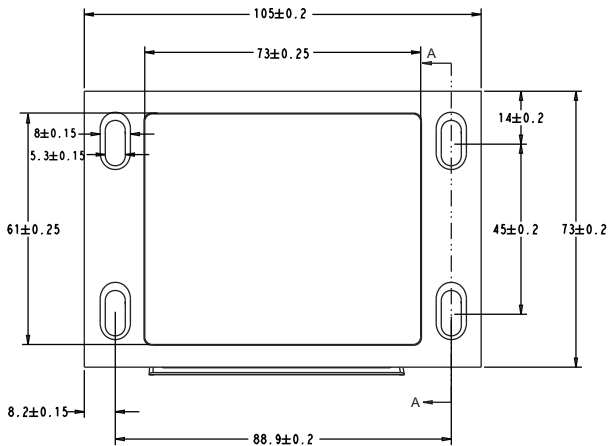

Mounting hole recess  
(section A-A)

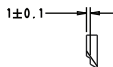

## User Feedback Pins

User feedback pins give you access to the trigger, beeper and good read lines on the scan engine. See the *CF4680 Installation Guide* for details on these pins (available from your local Honeywell OEM representative).

## Exit Window

The exit window is made of chemically strengthened glass and is scratch resistant. To clean the window, use one of the following:

- Sani-Cloth<sup>®</sup> HB wipes
- Sani-Cloth<sup>®</sup> Plus wipes
- Super Sani-Cloth<sup>®</sup> wipes
- Isopropyl Alcohol wipes (70%)
- CaviWipes<sup>™</sup>
- Virex<sup>®</sup> 256
- 409<sup>®</sup> Glass and Surface Cleaner
- Windex<sup>®</sup> Blue
- Clorox<sup>®</sup> Bleach – 10%
- Gentle dish soap and water

**Note:** *For best scanner and movement detector performance, do not cover the existing exit window with another window or use a different exit window.*

## Customer Support and Technical Assistance

For customer support, contact your local Honeywell Sales Representative or fill out the support form at [sps.honeywell.com/us/en/contact-us](https://sps.honeywell.com/us/en/contact-us).

## Limited Warranty

For warranty information, go to [sps.honeywell.com/us/en/support/productivity/warranties](https://sps.honeywell.com/us/en/support/productivity/warranties).

## Patents

For patent information, see [sps.honeywell.com/us/en/support/patents](https://sps.honeywell.com/us/en/support/patents).

## Disclaimer

Honeywell International Inc. and its affiliates, subsidiaries, and other entities forming part of Honeywell group (“HII”) reserves the right to make changes in specifications and other information contained in this document without prior notice, and the reader should in all cases consult HII to determine whether any such changes have been made. The information in this publication does not represent a commitment on the part of HII.

Honeywell warrants goods of its manufacture as being free of defective materials and faulty workmanship during the applicable warranty period. Honeywell’s standard product warranty applies unless agreed to otherwise by Honeywell in writing; please refer to your order acknowledgment or consult your local sales office for specific warranty details. If warranted goods are returned to Honeywell during the period of coverage, Honeywell will repair or replace, at its option, without charge those items that Honeywell, in its sole discretion, finds defective. **The foregoing is buyer’s sole remedy and is in lieu of all other warranties, expressed or implied, including those of merchantability and fitness for a particular purpose. In no event shall Honeywell be liable for consequential, special, or indirect damages.** While Honeywell may provide application assistance personally, through our literature and the Honeywell web site, it is buyer’s sole responsibility to determine the suitability of the product in the application. Specifications may change

without notice. The information we supply is believed to be accurate and reliable as of this writing. However, Honeywell assumes no responsibility for its use.

This document contains proprietary information that is protected by copyright. All rights are reserved. No part of this document may be photocopied, reproduced, or translated into another language without the prior written consent of HII.

Copyright © 2021 Honeywell International Inc. All rights reserved.

Web Address: [sps.honeywell.com/us/en/products/sensing-and-iot](https://sps.honeywell.com/us/en/products/sensing-and-iot)

Other product names or marks mentioned in this document may be trademarks or registered trademarks of other companies and are the property of their respective owners.